

ARMY TM 10-3930-675-24-1

MARINE CORPS TM 11078A-IN/3

TECHNICAL MANUAL

FIELD AND SUSTAINMENT MAINTENANCE MANUAL (Includes Unit, Direct, and General Support)

FOR

**ROUGH TERRAIN CONTAINER HANDLER (RTCH):
RT 240; 53,000 LB CAPACITY; 4 X 4
(NSN 3930-01-473-3998)**

**ROUGH TERRAIN CONTAINER HANDLER (RTCH):
RT 240; 53,000 LB CAPACITY; 4 X 4 (RESET)
(NSN 3930-01-473-3998)**

**ROUGH TERRAIN CONTAINER HANDLER (RTCH):
RT 240V2; 53,000 LB CAPACITY; 4 X 4
(NSN 3930-01-522-7364)**



SUPERSEDURE NOTICE - This manual supersedes TM 10-3930-675-20-1, TM 10-3930-675-20-2, and TM 10-3930-675-34 dated 1 July 2001.

DISTRIBUTION STATEMENT A - Approved for public release; distribution is unlimited.

HEADQUARTERS, DEPARTMENT OF THE ARMY

DECEMBER 2006

Publication Control Number: 184 110782 00

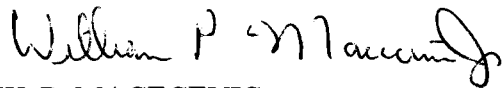
DEPARTMENT OF THE NAVY
Headquarters, U.S. Marine Corps
Washington, DC 20380-0001

25 September 2006

1. This Technical Manual (TM), authenticated for Marine Corps use and effective upon receipt, provides maintenance instructions as determined by TM 11078-IN for Rough Terrain Container Handler (RTCH), National Stock Number (NSN) 3830-01-522-7364.
2. Submit notice of discrepancies or suggested changes on a NAVMC 10772. The NAVMC may be submitted via the Internet using website <https://pubs.ala.usmc.mil/home.htm>, scrolling down to the NAVMC 10772 Tracking Program and following instructions provided. It may also be submitted by electronic mail to mbmatcommarlogbases@logcom.usmc.mil, or by mailing paper copy NAVMC 10772 in an envelope addressed to Commander, Marine Corps Systems Command, Attn: Assistant Commander Acquisition and Logistics (LOG/TP), 814 Radford Blvd, Suite 20343, Albany, Georgia 31704-0343.

BY DIRECTION OF THE COMMANDANT OF THE MARINE CORPS

OFFICIAL:



W. P. MACECEVIC
Program Manager, Engineer Systems
Marine Corps Systems Command

DISTRIBUTION: EDO

WARNING SUMMARY

This warning summary contains general safety warnings and hazardous materials warnings that must be understood and applied during operation and maintenance of this equipment. Failure to observe these precautions could result in serious injury or death to personnel. Also included are explanations of safety and hazardous materials icons used within the technical manual.



BIOLOGICAL - abstract symbol bug shows that a material may contain bacteria or viruses that present a danger to life or health.



CHEMICAL - drops of liquid on hand shows that the material will cause burns or irritation to human skin or tissue.



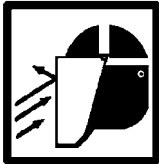
ELECTRICAL - electrical wire to arm with electricity symbol running through human body shows that shock hazard is present.



EYE PROTECTION - person with goggles shows that the material will injure the eyes.



FIRE - flame shows that a material may ignite and cause burns.



FLYING PARTICLES - arrows bouncing off face with face shield shows that particles flying through the air will harm face.



HEAVY OBJECT - human figure stooping over heavy object shows physical injury potential from improper lifting technique.



HEAVY PARTS - hand with heavy object on top shows that heavy parts can crush and harm.



HEAVY PARTS - heavy object on human figure shows that heavy parts present a danger to life or limb.



HOT AREA - hand over object radiating heat shows that part is hot and can burn.



RADIOACTIVE - identifies a material that emits radioactive energy and can injure human tissue or organs.



SLICK FLOOR - wavy line on floor with legs prone shows that slick floor presents a danger from falling. RADIOACTIVE - identifies a material that emits radioactive energy and can injure human tissue or organs.



VAPOR - human figure in a cloud shows that material vapors present a danger to life or health.



HYDRAULIC FLUID PRESSURE - hydraulic fluid spraying human figure shows that fluid escaping under great pressure can cause injury or death.

FOR INFORMATION ON FIRST AID, REFER TO FM 4-25.11.



WARNING

CARBON MONOXIDE (EXHAUST GASES) CAN KILL!

- Carbon monoxide is a colorless, odorless, deadly poison which, when breathed, deprives the body of oxygen and causes suffocation. Exposure to air containing carbon monoxide produces symptoms of headache, dizziness, loss of muscular control, apparent drowsiness, and coma. Permanent brain damage or death can result from severe exposure.
 - Carbon monoxide occurs in exhaust fumes of internal combustion engines. Carbon monoxide can become dangerously concentrated under conditions of inadequate ventilation. The following precautions must be observed to ensure safety of personnel when engine of RTCH is operated.
1. **DO NOT** operate RTCH engine in enclosed areas.
 2. **DO NOT** idle RTCH engine without adequate ventilation.
 3. **DO NOT** drive RTCH with inspection plates or cover plates removed.
 4. **BE ALERT** for exhaust poisoning symptoms. They are:
 - Headache
 - Dizziness
 - Sleepiness
 - Loss of muscular control
 5. **If you see another person with exhaust poisoning symptoms:**
 - Remove person from area.
 - Expose to fresh air.
 - Keep person warm.
 - Do not permit physical exercise.
 - Administer cardiopulmonary resuscitation (CPR), if necessary.
 - Notify a medic.
 6. **BE AWARE.** The field protective mask for nuclear-biological-chemical (NBC) protection will not protect you from carbon monoxide poisoning.

The Best Defense Against Carbon Monoxide Poisoning Is Good Ventilation!



WARNING
BATTERIES

- To avoid injury, eye protection and acid-resistant gloves must be worn when working around batteries. DO NOT smoke, use open flame, make sparks or create other ignition sources around batteries. If a battery is giving off gases, it can explode and cause injury to personnel. Remove all jewelry such as rings, ID tags, watches, and bracelets. If jewelry or a tool contacts a battery terminal, a direct short will result in instant heating, damage to equipment, and injury to personnel.
- Sulfuric acid contained in batteries can cause serious burns. If battery corrosion or electrolyte makes contact with skin, eyes, or clothing, take immediate action to stop the corrosive burning effects. Failure to follow these procedures may result in death or serious injury to personnel.
 - a. Eyes. Flush with cold water for no less than 15 minutes and seek medical attention immediately.
 - b. Skin. Flush with large amounts of cold water until all acid is removed. Seek medical attention as required.
 - c. Internal. If corrosion or electrolyte is ingested, drink large amounts of water or milk. Follow with milk of magnesia, beaten egg, or vegetable oil. Seek medical attention immediately.
 - d. Clothing/Equipment. Wash area with large amounts of cold water. Neutralize acid with baking soda or household ammonia.

WARNING

CLEANING AGENTS

Improper cleaning methods and use of unauthorized cleaning agents can injure personnel and damage equipment. To prevent this, refer to TM 9-247 for further instructions.



WARNING
COMPRESSED AIR

Compressed air used for cleaning or drying purposes, or for clearing restrictions, should never exceed 30 psi (207 kPa). Use protective equipment and exercise caution to avoid injury to personnel.



WARNING
DIESEL FUEL HANDLING

- DO NOT perform fuel system checks, inspections or maintenance while smoking or near fire, flames, or sparks. Fuel may ignite, causing damage to vehicle and injury or death to personnel.
- Wear fuel-resistant gloves when handling fuels and promptly wash exposed skin and change fuel-soaked clothing.



WARNING

DRY CLEANING SOLVENT



Dry cleaning solvent P-D-680 type III is toxic and flammable. Wear protective goggles and gloves and use only in a well-ventilated area. Avoid contact with skin, eyes, and clothes and do not breathe vapors. **DO NOT** use near open flames or excessive heat. The solvent's flash point is 200°F (94°C). If you become dizzy while using dry cleaning solvent, get fresh air immediately and get medical attention. If solvent contacts eyes, wash your eyes and seek medical attention immediately.



WARNING

ELECTRICAL SYSTEM MAINTENANCE

Remove all jewelry, watches, rings, etc. prior to disconnecting cables from batteries or other electrical source. Items can come in contact with battery or electrical source and cause electrical shock. Failure to follow this warning may result in personnel injury or death.



WARNING

ETHER COLD START SYSTEM

- Ether is extremely flammable and explosive. **DO NOT** perform ether cold start system checks, inspections or maintenance while smoking or near fire, flames or sparks. Failure to follow this warning may cause a fire and explosion, causing serious injury or death to personnel.
- Avoid breathing cold start system fluid vapors. Wear goggles and fuel-resistant gloves when handling fluid. Failure to follow this warning may cause serious injury or death to personnel.



WARNING

FIRE EXTINGUISHER

Discharging large quantities of dry chemical fire extinguisher in cab may result in temporary breathing difficulty during and immediately after the discharge event. If at all possible, discharge fire extinguisher from outside the cab. Ventilate cab thoroughly prior to reentry.



WARNING

HAZARDOUS WASTE DISPOSAL

When servicing this vehicle, performing maintenance, or disposing of materials such as engine coolant, hydraulic fluid, lubricants, battery acids or batteries, and CARC paint, consult your unit/local hazardous waste disposal center or safety office for local regulatory guidance. If further information is needed, please contact The Army Environmental Hotline at 1-800-872-3845.



WARNING
HYDRAULIC SYSTEM



- **DO NOT** disconnect or remove any hydraulic system line or fitting unless hydraulic system pressure has been relieved. Tighten all connections before applying pressure. Escaping hydraulic fluid under pressure can penetrate the skin, causing serious injury.
- Search for leaks with a piece of cardboard. Protect hands and body from high-pressure fluids. If an accident occurs, see a doctor immediately. Any fluid injected into the skin must be surgically removed within a few hours or gangrene may result.
- At operating temperature, hydraulic oil is hot. Allow hydraulic oil to cool before disconnecting any hydraulic lines. Failure to do so could result in injury.
- Hydraulic fluid is very slippery. Immediately wipe up any spills. Failure to follow this warning may result in injury to personnel.

WARNING

IR LIGHTS

DO NOT look directly at IR source without eye protection and maintain a minimum of 12 inches from energized IR lights to prevent possible eye discomfort or damage.



WARNING
LIFTING HEAVY COMPONENTS



- Hydraulic jacks are intended only for lifting RTCH, not for supporting vehicle to perform maintenance. **DO NOT** get under vehicle after it is raised unless it is properly supported with blocks or other suitable cribbing. Failure to observe this warning may result in death or injury to personnel.
- Use extreme caution when handling heavy parts. Provide adequate support and use assistance during procedure. Ensure that any lifting device used is in good condition and of suitable load capacity. Keep clear of heavy parts supported only by lifting device. Failure to follow this warning may result in death or injury to personnel.
- Improper use of lifting equipment and improper attachment of cables to vehicle can result in serious personnel injury and equipment damage. Observe all standard rules of safety.



WARNING
NBC EXPOSURE



If NBC exposure is suspected, all air cleaner media should be handled by personnel wearing protective equipment. Consult your NBC Officer or NBC NCO for appropriate handling or disposal procedures.



To order this NBC decal use:

National Stock Number (NSN) - 7690-01-114-3702

Part Number (PN) - 12296626

Commercial and Government Entity Code (CAGEC) - 19207

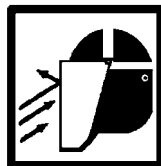


WARNING



PRESSURIZED COOLING SYSTEM

- DO NOT service cooling system unless engine has been allowed to cool down. This is a pressurized cooling system and escaping steam or hot coolant will cause serious burns.
- DO NOT remove cooling system radiator cap when engine is hot. Allow engine to cool down. Failure to follow this warning may cause serious burns.
- Wear effective eye, glove, and skin protection when handling coolants. Failure to do so may cause injury.



WARNING

R-134A REFRIGERANT



- Liquid refrigerant, when exposed to air, quickly evaporates and will freeze skin or eye tissue. Take care to prevent refrigerant from touching your skin or eyes. Serious injury or blindness may result if you come in contact with liquid refrigerant.
- Refrigerant R-134a air conditioning systems should not be pressure tested or leak tested with compressed air. Combustible mixtures of air and R-134a may form, resulting in a fire or explosion, which could cause personnel injury.



WARNING

SLAVE STARTING

- **When slave starting RTCH, use NATO slave cable that DOES NOT have loose or missing insulation.**
- **DO NOT proceed if suitable cable is not available.**
- **DO NOT use civilian-type jumper cables.**

LIST OF EFFECTIVE PAGES/WORK PACKAGES

NOTE: This manual supersedes TM 10-3930-675-20-1, TM 10-3930-675-20-2, and TM 10-3930-675-34 dated 1 July 2001.

Date of Issue1 December 2006

Total number of pages for front and rear matter is 32 and total number of work packages is 48 consisting of the following:

VOLUME I

Page/WP No.	*Change No.	Page/WP No.	*Change No.
Cover	0	WP 0030 00 (4 pages)	0
Warning Summary	0	WP 0031 00 (6 pages)	0
i to xii	0	WP 0032 00 (8 pages)	0
Ch. 1 title page	0	WP 0033 00 (18 pages)	0
WP 0001 00 (4 pages)	0	WP 0034 00 (4 pages)	0
WP 0002 00 (8 pages)	0	WP 0035 00 (18 pages)	0
WP 0003 00 (4 pages)	0	WP 0036 00 (2 pages)	0
Ch. 2 title page	0	WP 0037 00 (6 pages)	0
WP 0004 00 (40 pages)	0	WP 0038 00 (4 pages)	0
WP 0005 00 (46 pages)	0	WP 0039 00 (10 pages)	0
WP 0006 00 (12 pages)	0	WP 0040 00 (10 pages)	0
WP 0007 00 (94 pages)	0	WP 0041 00 (8 pages)	0
WP 0008 00 (74 pages)	0	WP 0042 00 (8 pages)	0
WP 0009 00 (24 pages)	0	WP 0043 00 (10 pages)	0
WP 0010 00 (6 pages)	0	WP 0044 00 (10 pages)	0
WP 0011 00 (16 pages)	0	WP 0045 00 (6 pages)	0
WP 0012 00 (4 pages)	0	WP 0046 00 (6 pages)	0
WP 0013 00 (14 pages)	0	WP 0047 00 (10 pages)	0
WP 0014 00 (14 pages)	0	WP 0048 00 (62 pages)	0
WP 0015 00 (10 pages)	0	Index (14 pages)	0
WP 0016 00 (10 pages)	0		
WP 0017 00 (24 pages)	0		
WP 0018 00 (20 pages)	0		
WP 0019 00 (10 pages)	0		
WP 0020 00 (14 pages)	0		
WP 0021 00 (28 pages)	0		
WP 0022 00 (16 pages)	0		
WP 0023 00 (18 pages)	0		
WP 0024 00 (16 pages)	0		
WP 0025 00 (10 pages)	0		
WP 0026 00 (8 pages)	0		
WP 0027 00 (12 pages)	0		
WP 0028 00 (20 pages)	0		
WP 0029 00 (8 pages)	0		

*Zero in this column indicates an original page or work package.

VOLUME II

Page/WP No.	*Change No.	Page/WP No.	*Change No.
Cover	0	WP 0087 00 (4 pages)	0
Warning Summary	0	WP 0088 00 (6 pages)	0
i to iv	0	WP 0089 00 (2 pages)	0
Ch. 3 title page	0	WP 0090 00 (2 pages)	0
WP 0049 00 (2 pages)	0	WP 0091 00 (2 pages)	0
WP 0050 00 (22 pages)	0	WP 0092 00 (2 pages)	0
WP 0051 00 (6 pages)	0	WP 0093 00 (2 pages)	0
WP 0052 00 (4 pages)	0	WP 0094 00 (6 pages)	0
WP 0053 00 (4 pages)	0	WP 0095 00 (4 pages)	0
WP 0054 00 (4 pages)	0	WP 0096 00 (6 pages)	0
WP 0055 00 (6 pages)	0	WP 0097 00 (4 pages)	0
WP 0056 00 (2 pages)	0	WP 0098 00 (4 pages)	0
WP 0057 00 (4 pages)	0	WP 0099 00 (4 pages)	0
WP 0058 00 (4 pages)	0	WP 0100 00 (4 pages)	0
WP 0059 00 (4 pages)	0	WP 0101 00 (6 pages)	0
WP 0060 00 (6 pages)	0	WP 0102 00 (4 pages)	0
WP 0061 00 (8 pages)	0	WP 0103 00 (4 pages)	0
WP 0062 00 (4 pages)	0	WP 0104 00 (8 pages)	0
WP 0063 00 (4 pages)	0	WP 0105 00 (2 pages)	0
WP 0064 00 (4 pages)	0	WP 0106 00 (2 pages)	0
WP 0065 00 (12 pages)	0	WP 0107 00 (4 pages)	0
WP 0066 00 (6 pages)	0	WP 0108 00 (2 pages)	0
WP 0067 00 (4 pages)	0	WP 0109 00 (4 pages)	0
WP 0068 00 (6 pages)	0	WP 0110 00 (6 pages)	0
WP 0069 00 (4 pages)	0	WP 0111 00 (4 pages)	0
WP 0070 00 (4 pages)	0	WP 0012 00 (4 pages)	0
WP 0071 00 (4 pages)	0	WP 0113 00 (12 pages)	0
WP 0072 00 (4 pages)	0	WP 0114 00 (8 pages)	0
WP 0073 00 (10 pages)	0	WP 0115 00 (6 pages)	0
WP 0074 00 (10 pages)	0	WP 0116 00 (4 pages)	0
WP 0075 00 (10 pages)	0	WP 0117 00 (8 pages)	0
WP 0076 00 (6 pages)	0	WP 0118 00 (4 pages)	0
WP 0077 00 (4 pages)	0	WP 0119 00 (6 pages)	0
WP 0078 00 (4 pages)	0	WP 0120 00 (6 pages)	0
WP 0079 00 (4 pages)	0	WP 0121 00 (2 pages)	0
WP 0080 00 (8 pages)	0	WP 0122 00 (4 pages)	0
WP 0081 00 (4 pages)	0	WP 0123 00 (4 pages)	0
WP 0082 00 (2 pages)	0	WP 0124 00 (4 pages)	0
WP 0083 00 (8 pages)	0	WP 0125 00 (2 pages)	0
WP 0084 00 (4 pages)	0	WP 0126 00 (2 pages)	0
WP 0085 00 (4 pages)	0	WP 0127 00 (4 pages)	0
WP 0086 00 (4 pages)	0		

*Zero in this column indicates an original page or work package.

TM 10-3930-675-24-1

Page/WP No.	*Change No.	Page/WP No.	*Change No.
WP 0128 00 (4 pages)	0	WP 0171 00 (6 pages)	0
WP 0129 00 (4 pages)	0	WP 0172 00 (2 pages)	0
WP 0130 00 (2 pages)	0	WP 0173 00 (4 pages)	0
WP 0131 00 (2 pages)	0	WP 0174 00 (2 pages)	0
WP 0132 00 (8 pages)	0	WP 0175 00 (2 pages)	0
WP 0133 00 (8 pages)	0	WP 0176 00 (2 pages)	0
WP 0134 00 (2 pages)	0	WP 0177 00 (2 pages)	0
WP 0135 00 (4 pages)	0	WP 0178 00 (2 pages)	0
WP 0136 00 (4 pages)	0	WP 0179 00 (2 pages)	0
WP 0137 00 (2 pages)	0	WP 0180 00 (2 pages)	0
WP 0138 00 (24 pages)	0	WP 0181 00 (2 pages)	0
WP 0139 00 (2 pages)	0	WP 0182 00 (2 pages)	0
WP 0140 00 (4 pages)	0	WP 0183 00 (2 pages)	0
WP 0141 00 (4 pages)	0	WP 0184 00 (2 pages)	0
WP 0142 00 (6 pages)	0	WP 0185 00 (6 pages)	0
WP 0143 00 (2 pages)	0	WP 0186 00 (4 pages)	0
WP 0144 00 (2 pages)	0	WP 0187 00 (2 pages)	0
WP 0145 00 (2 pages)	0	WP 0188 00 (8 pages)	0
WP 0146 00 (14 pages)	0	WP 0189 00 (16 pages)	0
WP 0147 00 (14 pages)	0	WP 0190 00 (12 pages)	0
WP 0148 00 (4 pages)	0	WP 0191 00 (4 pages)	0
WP 0149 00 (10 pages)	0	WP 0192 00 (8 pages)	0
WP 0150 00 (2 pages)	0	WP 0193 00 (2 pages)	0
WP 0151 00 (2 pages)	0	WP 0194 00 (2 pages)	0
WP 0152 00 (4 pages)	0	WP 0195 00 (2 pages)	0
WP 0153 00 (4 pages)	0	WP 0196 00 (6 pages)	0
WP 0154 00 (4 pages)	0	Ch. 4 title page	0
WP 0155 00 (4 pages)	0	WP 0197 00 (16 pages)	0
WP 0156 00 (2 pages)	0	WP 0198 00 (6 pages)	0
WP 0157 00 (4 pages)	0	WP 0199 00 (16 pages)	0
WP 0158 00 (10 pages)	0	WP 0200 00 (16 pages)	0
WP 0159 00 (6 pages)	0	WP 0201 00 (4 pages)	0
WP 0160 00 (2 pages)	0	WP 0202 00 (4 pages)	0
WP 0161 00 (2 pages)	0	WP 0203 00 (4 pages)	0
WP 0162 00 (2 pages)	0	WP 0204 00 (6 pages)	0
WP 0163 00 (8 pages)	0	WP 0205 00 (10 pages)	0
WP 0164 00 (4 pages)	0	WP 0206 00 (12 pages)	0
WP 0165 00 (6 pages)	0	WP 0207 00 (10 pages)	0
WP 0166 00 (8 pages)	0	WP 0208 00 (4 pages)	0
WP 0167 00 (10 pages)	0	WP 0209 00 (12 pages)	0
WP 0168 00 (14 pages)	0	WP 0210 00 (4 pages)	0
WP 0169 00 (6 pages)	0	WP 0211 00 (2 pages)	0
WP 0170 00 (2 pages)	0	WP 0212 00 (6 pages)	0

*Zero in this column indicates an original page or work package.

TM 10-3930-675-24-1

Page/WP No.	*Change No.	Page/WP No.	*Change No.
WP 0213 00 (16 pages)	0	WP 0256 00 (4 pages)	0
WP 0214 00 (8 pages)	0	WP 0257 00 (4 pages)	0
WP 0215 00 (4 pages)	0	WP 0258 00 (6 pages)	0
WP 0216 00 (4 pages)	0	WP 0259 00 (6 pages)	0
WP 0217 00 (8 pages)	0	WP 0260 00 (4 pages)	0
WP 0218 00 (4 pages)	0	WP 0261 00 (2 pages)	0
WP 0219 00 (6 pages)	0	WP 0262 00 (14 pages)	0
WP 0220 00 (4 pages)	0	WP 0263 00 (28 pages)	0
WP 0221 00 (18 pages)	0	WP 0264 00 (4 pages)	0
WP 0222 00 (8 pages)	0	WP 0265 00 (6 pages)	0
WP 0223 00 (4 pages)	0	WP 0266 00 (4 pages)	0
WP 0224 00 (18 pages)	0	WP 0267 00 (12 pages)	0
WP 0225 00 (4 pages)	0	WP 0268 00 (4 pages)	0
WP 0226 00 (6 pages)	0	WP 0269 00 (4 pages)	0
WP 0227 00 (8 pages)	0	Ch. 5 title page	0
WP 0228 00 (6 pages)	0	WP 0270 00 (10 pages)	0
WP 0229 00 (8 pages)	0	WP 0271 00 (14 pages)	0
WP 0230 00 (2 pages)	0	WP 0272 00 (16 pages)	0
WP 0231 00 (6 pages)	0	WP 0273 00 (18 pages)	0
WP 0232 00 (4 pages)	0	WP 0274 00 (12 pages)	0
WP 0233 00 (8 pages)	0	WP 0275 00 (10 pages)	0
WP 0234 00 (2 pages)	0	WP 0276 00 (16 pages)	0
WP 0235 00 (2 pages)	0	WP 0277 00 (10 pages)	0
WP 0236 00 (4 pages)	0	WP 0278 00 (8 pages)	0
WP 0237 00 (2 pages)	0	WP 0279 00 (4 pages)	0
WP 0238 00 (4 pages)	0	WP 0280 00 (4 pages)	0
WP 0239 00 (8 pages)	0	WP 0281 00 (10 pages)	0
WP 0240 00 (6 pages)	0	WP 0282 00 (2 pages)	0
WP 0241 00 (4 pages)	0	WP 0283 00 (4 pages)	0
WP 0242 00 (16 pages)	0	WP 0284 00 (8 pages)	0
WP 0243 00 (6 pages)	0	WP 0285 00 (2 pages)	0
WP 0244 00 (4 pages)	0	WP 0286 00 (2 pages)	0
WP 0245 00 (4 pages)	0	Ch. 6 title page	0
WP 0246 00 (4 pages)	0	WP 0287 00 (2 pages)	0
WP 0247 00 (4 pages)	0	WP 0288 00 (4 pages)	0
WP 0248 00 (4 pages)	0	WP 0289 00 (24 pages)	0
WP 0249 00 (6 pages)	0	WP 0290 00 (6 pages)	0
WP 0250 00 (4 pages)	0	WP 0291 00 (6 pages)	0
WP 0251 00 (4 pages)	0	WP 0292 00 (Foldouts 20 pages)	0
WP 0252 00 (6 pages)	0	Index (14 pages)	0
WP 0253 00 (8 pages)	0		
WP 0254 00 (6 pages)	0		
WP 0255 00 (4 pages)	0		

*Zero in this column indicates an original page or work package.

TECHNICAL MANUAL
TM 10-3930-675-24-1
TM 11078A-IN/3

HEADQUARTERS
DEPARTMENT OF THE ARMY
Washington, D.C., 1 December 2006

TECHNICAL MANUAL

FIELD AND SUSTAINMENT MAINTENANCE MANUAL
(Including Unit, Direct, and General Support)

FOR

ROUGH TERRAIN CONTAINER HANDLER (RTCH):
RT 240; 53,000 LB CAPACITY; 4 X 4
(NSN 3930-01-473-3998)

ROUGH TERRAIN CONTAINER HANDLER (RTCH):
RT 240; 53,000 LB CAPACITY; 4 X 4 (RESET)
(NSN 3930-01-473-3998)

ROUGH TERRAIN CONTAINER HANDLER (RTCH):
RT 240V2; 53,000 LB CAPACITY; 4 X 4
(NSN 3930-01-522-7364)

REPORTING ERRORS AND RECOMMENDING IMPROVEMENTS

You can help improve this publication. If you find any mistakes or if you know of a way to improve the procedures, please let us know. Submit your DA Form 2028 (*Recommended Changes to Publications and Blank Forms*), through the Internet, on the Army Electronic Product Support (AEPS) website. The Internet address is <https://aeprs.ria.army.mil/>. The DA Form 2028 is located under the Public Applications section in the AEPS Public Home Page. Fill out the form and click on SUBMIT. Using this form on the AEPS will enable us to respond quicker to your comments and better manage the DA Form 2028 program. You may also mail, fax or e-mail your letter or DA Form 2028 direct to: AMSTA-LC-LPIT/TECH PUBS, TACOM-RI, 1 Rock Island Arsenal, Rock Island, IL 61299-7630. The e-mail address is: ROCK-TACOM-TECH-PUBS@conus.army.mil. The fax number is DSN 793-0726 or Commercial (309) 782-0726.

SUPERSEDURE NOTICE - This manual supersedes TM 10-3930-675-20-1, TM 10-3930-675-20-2, and TM 10-3930-675-34 dated 1 July 2001.

DISTRIBUTION STATEMENT A - Approved for public release; distribution is unlimited.

Table of Contents

	Page Number
VOLUME I	
Warning Summary	a
How To Use This Manual	xi
CHAPTER 1 INTRODUCTORY INFORMATION WITH THEORY OF OPERATION	
WP 0001 00 General Information	0001 00-1
WP 0002 00 Equipment Description and Data.	0002 00-1
WP 0003 00 Theory of Operation	0003 00-1

Table of Contents - Continued

	Page Number
CHAPTER 2 TROUBLESHOOTING PROCEDURES	
WP 0004 00 Troubleshooting Introduction	0004 00-1
WP 0005 00 Error Codes	0005 00-1
WP 0006 00 Troubleshooting Symptom Index	0006 00-1
WP 0007 00 Troubleshooting Procedures (Non-Error Code)	0007 00-1
WP 0008 00 Engine Fuel Injector Circuits Troubleshooting	0008 00-1
WP 0009 00 Engine TPS and Idle Validation Switch Troubleshooting	0009 00-1
WP 0010 00 Cooling Fan Operation and Fan Control Troubleshooting	0010 00-1
WP 0011 00 Overload Protection Troubleshooting	0011 00-1
WP 0012 00 Tophandler Electronic Control Unit (ECU) (791) Troubleshooting	0012 00-1
WP 0013 00 Electronic Control Unit (ECU) Input Voltage Troubleshooting	0013 00-1
WP 0014 00 ECU-to-ECU Communications Troubleshooting	0014 00-1
WP 0015 00 Steering ECU (792), Transmission ECU (793), and Engine ECU (794) Troubleshooting.	0015 00-1
WP 0016 00 Electronic Control Unit (ECU) Supply Voltage Troubleshooting	0016 00-1
WP 0017 00 Input and Output Signals For Steering ECU (792) Troubleshooting	0017 00-1
WP 0018 00 Engine Electronic Control Unit (ECU) (791) Troubleshooting	0018 00-1
WP 0019 00 Engine Position Sensor Circuits Troubleshooting.	0019 00-1
WP 0020 00 Engine Oil Pressure Sensor Troubleshooting	0020 00-1
WP 0021 00 Engine Temperature Sensors and Circuits Troubleshooting	0021 00-1
WP 0022 00 Engine Ambient Air Pressure Sensor and Circuits Troubleshooting	0022 00-1
WP 0023 00 Engine Pressure Sensor Troubleshooting	0023 00-1
WP 0024 00 Engine Fuel Pressure Sensors and Circuits Troubleshooting	0024 00-1
WP 0025 00 Engine Battery Voltage Circuits Troubleshooting	0025 00-1
WP 0026 00 Transmission Temperature Troubleshooting	0026 00-1
WP 0027 00 Transmission Speed Sensors Troubleshooting	0027 00-1
WP 0028 00 Transmission Clutch Circuit Troubleshooting	0028 00-1
WP 0029 00 Miscellaneous Transmission Failure Troubleshooting	0029 00-1
WP 0030 00 Internal Transmission Clutch Slippage Failure Troubleshooting	0030 00-1
WP 0031 00 Brake System Troubleshooting	0031 00-1
WP 0032 00 Axle Brake Cooling System Troubleshooting.	0032 00-1
WP 0033 00 Steering Valve Circuit Troubleshooting	0033 00-1
WP 0034 00 Mechanical or Hydraulic Steering Failure Troubleshooting	0034 00-1
WP 0035 00 Steering Sensor Troubleshooting	0035 00-1
WP 0036 00 Hydraulic Servo System Electronic Control Unit (ECU) (790) Troubleshooting.	0036 00-1
WP 0037 00 Auxiliary Pump Troubleshooting	0037 00-1
WP 0038 00 Hydraulic Piston Pump Cut-Off Troubleshooting.	0038 00-1
WP 0039 00 Hydraulic Filter Indicators Troubleshooting	0039 00-1
WP 0040 00 Boom Lifting/Lowering Troubleshooting.	0040 00-1
WP 0041 00 Boom In/Out Troubleshooting	0041 00-1
WP 0042 00 Tophandler Slewing Troubleshooting	0042 00-1
WP 0043 00 Tophandler Tilt Troubleshooting	0043 00-1
WP 0044 00 Tophandler Leveling Troubleshooting	0044 00-1
WP 0045 00 Tophandler Sideshift Troubleshooting	0045 00-1
WP 0046 00 Tophandler Spreader Troubleshooting	0046 00-1
WP 0047 00 Tophandler Twistlocks and Forklift Sensor Troubleshooting.	0047 00-1
WP 0048 00 Diagrams	0048 00-1

Table of Contents - Continued

Page
Number

VOLUME II

CHAPTER 3 ORGANIZATIONAL MAINTENANCE INSTRUCTIONS

WP 0049 00	Service Upon Receipt	0049 00-1
WP 0050 00	Preventive Maintenance Checks and Services (PMCS) Introduction	0050 00-1
WP 0051 00	Preventive Maintenance Checks and Services (PMCS)	0051 00-1
<i>Engine</i>		
WP 0052 00	Rocker Arm Cover and Gasket Replacement	0052 00-1
WP 0053 00	Engine Oil and Oil Filter Replacement	0053 00-1
WP 0054 00	Engine Oil Dipstick Hose and Oil Fill Hose Replacement	0054 00-1
WP 0055 00	Oil Sampling Valves and Hoses Replacement	0055 00-1
<i>Fuel</i>		
WP 0056 00	Fuel Solenoid Shutoff Valve Replacement	0056 00-1
WP 0057 00	Engine Air Cleaner Maintenance	0057 00-1
WP 0058 00	Engine Air Intake Hoses and Tubes Replacement	0058 00-1
WP 0059 00	Fuel Filter/Water Separator Replacement	0059 00-1
WP 0060 00	Fuel Hoses, Lines, and Fittings Replacement	0060 00-1
WP 0061 00	Ether Cold Start System Maintenance	0061 00-1
WP 0062 00	Throttle Position Sensor (Accelerator Pedal) Replacement	0062 00-1
<i>Exhaust</i>		
WP 0063 00	Muffler and Exhaust Pipe Replacement	0063 00-1
<i>Cooling</i>		
WP 0064 00	Draining and Filling Radiator Assembly	0064 00-1
WP 0065 00	Cooling System Hoses Replacement	0065 00-1
WP 0066 00	Cooling System Expansion Tank Maintenance	0066 00-1
WP 0067 00	Thermostat Replacement	0067 00-1
WP 0068 00	Water Pump Replacement	0068 00-1
WP 0069 00	Coolant Filter Replacement	0069 00-1
<i>Electrical</i>		
WP 0070 00	Alternator Replacement	0070 00-1
WP 0071 00	Alternator Drive Belt Maintenance	0071 00-1
WP 0072 00	Starter Replacement	0072 00-1
WP 0073 00	Instrument Panel Switches, Gages, and Panel Lamps Replacement	0073 00-1
WP 0074 00	Circuit Breakers and Relays Replacement	0074 00-1
WP 0075 00	Tophandler Proximity Switches Replacement	0075 00-1
WP 0076 00	Cab Position Proximity Switches Replacement	0076 00-1
WP 0077 00	Tophandler Junction Box Maintenance	0077 00-1
WP 0078 00	Tophandler Proximity Switch Junction Boxes Replacement	0078 00-1

Table of Contents - Continued

	Page Number
<i>Electrical - Continued</i>	
WP 0079 00 Engine Electronic Control Module (ECM) Replacement	0079 00-1
WP 0080 00 Electronic Control Units (ECU) Replacement	0080 00-1
WP 0081 00 ECS Display Screen Replacement.	0081 00-1
WP 0082 00 Electronic Joystick Assembly Replacement	0082 00-1
WP 0083 00 Electronic Joystick Assembly Wiring Harness Replacement	0083 00-1
WP 0084 00 Headlight Maintenance	0084 00-1
WP 0085 00 Backup Light and Work Light Maintenance	0085 00-1
WP 0086 00 Directional and Side Marker Light Maintenance	0086 00-1
WP 0087 00 Blackout Light Maintenance	0087 00-1
WP 0088 00 Twistlock Indicator Lights Maintenance.	0088 00-1
WP 0089 00 Cab Interior Light Maintenance	0089 00-1
WP 0090 00 Infrared (IR) Lights Replacement	0090 00-1
WP 0091 00 Forging Water Level Sensor Replacement	0091 00-1
WP 0092 00 Ambient Temperature Sensor Replacement	0092 00-1
WP 0093 00 Wheel Temperature Sensor Replacement	0093 00-1
WP 0094 00 Engine Sensors Replacement	0094 00-1
WP 0095 00 Fuel Level Sending Unit Replacement	0095 00-1
WP 0096 00 Transmission Sensors Replacement	0096 00-1
WP 0097 00 Brake Inching Switch Replacement	0097 00-1
WP 0098 00 Brake Light and Pressure Switches Replacement.	0098 00-1
WP 0099 00 Boom Angle Sensor Replacement.	0099 00-1
WP 0100 00 Boom Extension Sensor Replacement.	0100 00-1
WP 0101 00 Tophandler Angle Sensor Replacement	0101 00-1
WP 0102 00 Hydraulic Reservoir and Lift Cylinder Sensors Replacement	0102 00-1
WP 0103 00 Hydraulic Filter Indicator Sensors Replacement.	0103 00-1
WP 0104 00 Steering System Wheel Sensor Replacement	0104 00-1
WP 0105 00 Electric Horn Replacement	0105 00-1
WP 0106 00 Backup Alarm Replacement	0106 00-1
WP 0107 00 Seat Warning Buzzer Replacement.	0107 00-1
WP 0108 00 Battery Maintenance	0108 00-1
WP 0109 00 Solar Charger Maintenance (USMC Only).	0109 00-1
WP 0110 00 Battery Cables Replacement	0110 00-1
WP 0111 00 Master Battery Switch Replacement	0111 00-1
WP 0112 00 Slave Starting Receptacle Replacement	0112 00-1
WP 0113 00 Electrical General Maintenance Instructions.	0113 00-1
<i>Transmission</i>	
WP 0114 00 Transmission and Accessory Control Levers Replacement	0114 00-1
WP 0115 00 Transmission Oil Filter and Oil Cooler Hoses and Fittings Replacement	0115 00-1
WP 0116 00 Transmission Assembly Hydraulic Hoses and Pipes Replacement	0116 00-1
WP 0117 00 Transmission Oil, Oil Filters, and Oil Filter Head Replacement	0117 00-1
WP 0118 00 Transmission Oil Dipstick Hose and Pipe Replacement.	0118 00-1
WP 0119 00 Transmission and Front and Rear Axle Vent Hoses Replacement	0119 00-1
<i>Propeller Shafts</i>	
WP 0120 00 Front and Rear Propeller Shafts Replacement.	0120 00-1
WP 0121 00 Propeller Shaft Universal Joint Replacement	0121 00-1

Table of Contents - Continued

	Page Number
<i>Brakes</i>	
WP 0122 00 Parking Brake Pads Maintenance	0122 00-1
WP 0123 00 Caging and Uncaging Parking Brake	0123 00-1
WP 0124 00 Parking Brake Control Valve Replacement	0124 00-1
WP 0125 00 Parking Brake System Hydraulic Hoses and Fittings Replacement	0125 00-1
WP 0126 00 Service Brake Control Valve Replacement	0126 00-1
WP 0127 00 Service Brake System Hydraulic Hoses and Fittings Replacement	0127 00-1
WP 0128 00 Brake Cooling Filter and Filter Head Replacement	0128 00-1
WP 0129 00 Brake System Charging Valve Pressure Adjustment	0129 00-1
<i>Wheels</i>	
WP 0130 00 Dolly Wheel Maintenance	0130 00-1
<i>Steering</i>	
WP 0131 00 Steering Wheel Replacement	0131 00-1
WP 0132 00 Steering Column Base and Brake Pedal Maintenance	0132 00-1
WP 0133 00 Steering Column Replacement	0133 00-1
WP 0134 00 Steering System Hydraulic Hoses and Fittings Replacement	0134 00-1
WP 0135 00 Front and Rear Axle Steering Cylinders Replacement	0135 00-1
WP 0136 00 Steering Column Sensor Replacement	0136 00-1
<i>Frame</i>	
WP 0137 00 Tow Pintle Replacement	0137 00-1
WP 0138 00 Cab Transport Lift Maintenance	0138 00-1
WP 0139 00 Right-Side Step Assembly Replacement	0139 00-1
WP 0140 00 Left-Side Stair Assembly Maintenance	0140 00-1
WP 0141 00 Autolube System Maintenance	0141 00-1
<i>Body, Cab, and Hood</i>	
WP 0142 00 Transmission Skid Plate and Access Covers Replacement	0142 00-1
WP 0143 00 Radiator Splash Shield Replacement	0143 00-1
WP 0144 00 Radiator Top Grating Replacement	0144 00-1
WP 0145 00 Radiator Fill Cover Plate Replacement	0145 00-1
WP 0146 00 Boom Assembly Wear Plates Replacement	0146 00-1
WP 0147 00 Tophandler Wear Plates Replacement	0147 00-1
WP 0148 00 Engine Cover Maintenance	0148 00-1
WP 0149 00 Fender Assembly Replacement (Army, RESET, and USMC)	0149 00-1
WP 0150 00 Mudguard Replacement	0150 00-1
WP 0151 00 Seat Belt Replacement	0151 00-1
WP 0152 00 Seat Assembly Maintenance	0152 00-1
WP 0153 00 Cab Door Weatherseal Replacement	0153 00-1
WP 0154 00 Storage Compartment Doors and Latches Replacement	0154 00-1
WP 0155 00 Battery and Dolly Wheels Storage Compartment Replacement	0155 00-1
WP 0156 00 Remote Hydraulic Control Compartment Replacement	0156 00-1
WP 0157 00 Rearview Mirrors Replacement	0157 00-1
WP 0158 00 Windshield Wiper Maintenance	0158 00-1
WP 0159 00 Windshield Washer Reservoir and Pump Replacement	0159 00-1
WP 0160 00 Data Plate Replacement	0160 00-1
WP 0161 00 Fire Extinguisher Bracket Replacement	0161 00-1
WP 0162 00 Rifle Mounting Bracket Replacement	0162 00-1

Table of Contents - Continued

Page
Number

Hydraulics

WP 0163 00	Boom-To-Boom Extension Flexible Conveyer Maintenance	0163 00-1
WP 0164 00	Relieving Hydraulic System Pressure	0164 00-1
WP 0165 00	Auxiliary Hydraulic Pump Replacement	0165 00-1
WP 0166 00	Tophandler Hydraulic Slewing Motors Replacement	0166 00-1
WP 0167 00	Tophandler Hydraulic Spreader Motor Replacement	0167 00-1
WP 0168 00	Spreader Chain Replacement	0168 00-1
WP 0169 00	Spreader 20 and 40 Foot Adjustment	0169 00-1
WP 0170 00	Cab Transport Control Valve Replacement	0170 00-1
WP 0171 00	Control Valve Solenoids Replacement	0171 00-1
WP 0172 00	Boom Folding Control Valve Replacement	0172 00-1
WP 0173 00	Cab Lifting Cylinder Replacement	0173 00-1
WP 0174 00	Cab Sliding Cylinder Replacement	0174 00-1
WP 0175 00	Tophandler Twistlock Cylinder Replacement	0175 00-1
WP 0176 00	Hydraulic System Cooling Hoses and Fittings Replacement	0176 00-1
WP 0177 00	Cab Parking and Service Brake Hydraulic Hoses and Fittings Replacement	0177 00-1
WP 0178 00	Main Hydraulic System Hoses and Fittings Replacement	0178 00-1
WP 0179 00	Hydraulic Servo System Hoses and Fittings Replacement	0179 00-1
WP 0180 00	Hydraulic System Test Point Hoses and Fittings Replacement	0180 00-1
WP 0181 00	Cab Transport Hydraulic Hoses and Fittings Replacement	0181 00-1
WP 0182 00	Boom Hydraulic System Hoses and Fittings Replacement	0182 00-1
WP 0183 00	Tophandler Hydraulic System Hoses and Fittings Replacement	0183 00-1
WP 0184 00	Forklift Kit Hydraulic Hoses and Fittings Replacement	0184 00-1
WP 0185 00	Hydraulic System Oil Filters Replacement	0185 00-1
WP 0186 00	Draining and Filling Hydraulic Reservoir	0186 00-1
WP 0187 00	Hydraulic Reservoir Sight Gage Replacement	0187 00-1
WP 0188 00	Hydraulic System Test Point Procedures	0188 00-1
WP 0189 00	Tophandler Replacement	0189 00-1

Refrigeration and Air Conditioning

WP 0190 00	Heater Hoses Replacement	0190 00-1
WP 0191 00	Cab Heater/Air Conditioning Blower Motor and Fan Replacement	0191 00-1
WP 0192 00	Cab Air Filters Replacement	0192 00-1
WP 0193 00	Cab Auxiliary Fan Replacement	0193 00-1
WP 0194 00	Air Conditioner Leak Test	0194 00-1
WP 0195 00	Air Conditioning Compressor Drive Belts Replacement	0195 00-1
WP 0196 00	Air Conditioner Fans Maintenance	0196 00-1

CHAPTER 4 DIRECT SUPPORT MAINTENANCE INSTRUCTIONS

Engine

WP 0197 00	Engine Assembly Replacement	0197 00-1
WP 0198 00	Engine Mounts and Lifting Brackets Replacement	0198 00-1
WP 0199 00	Cylinder Head Replacement	0199 00-1
WP 0200 00	Cylinder Head Repair	0200 00-1
WP 0201 00	Front Main Oil Seal Replacement	0201 00-1
WP 0202 00	Rear Main Oil Seal Replacement	0202 00-1
WP 0203 00	Vibration Damper Replacement	0203 00-1
WP 0204 00	Flywheel Assembly Replacement	0204 00-1

Table of Contents - Continued

	Page Number
<i>Engine - Continued</i>	
WP 0205 00 Flywheel Housing Replacement	0205 00-1
WP 0206 00 Rocker Arm Assembly Maintenance.	0206 00-1
WP 0207 00 Valve and Injector Adjustments	0207 00-1
WP 0208 00 Oil Pan Replacement	0208 00-1
WP 0209 00 Oil Filter Head and Oil Cooler Maintenance	0209 00-1
WP 0210 00 Exhaust Manifold Replacement	0210 00-1
WP 0211 00 Intake Manifold Replacement	0211 00-1
WP 0212 00 Front Gear Cover Replacement.	0212 00-1
WP 0213 00 Accessory Drive Assembly Maintenance	0213 00-1
WP 0214 00 Cooling Fan Hydraulic Pump Drive Gear Replacement.	0214 00-1
<i>Fuel</i>	
WP 0215 00 Fuel Injector Replacement.	0215 00-1
WP 0216 00 Fuel Pump Assembly Replacement.	0216 00-1
WP 0217 00 Turbocharger Replacement	0217 00-1
WP 0218 00 Fuel Tank Replacement.	0218 00-1
<i>Cooling</i>	
WP 0219 00 Radiator Assembly Replacement	0219 00-1
<i>Electrical</i>	
WP 0220 00 Boom Wiring Harnesses Replacement	0220 00-1
WP 0221 00 Tophandler Wiring Harnesses Replacement	0221 00-1
WP 0222 00 Tophandler Junction Box Replacement.	0222 00-1
<i>Transmission</i>	
WP 0223 00 Transmission Torque Converter Replacement	0223 00-1
WP 0224 00 Transmission Assembly Replacement.	0224 00-1
WP 0225 00 Transmission Calibration.	0225 00-1
WP 0226 00 Transmission Oil Cooler Replacement	0226 00-1
<i>Front Axle</i>	
WP 0227 00 Front Axle Assembly Replacement.	0227 00-1
<i>Rear Axle</i>	
WP 0228 00 Rear Axle Assembly Replacement	0228 00-1
<i>Brakes</i>	
WP 0229 00 Parking Brake Cylinder Maintenance	0229 00-1
WP 0230 00 Brake Accumulator Replacement	0230 00-1
WP 0231 00 Brake and Steering Accumulator Service	0231 00-1
<i>Wheels</i>	
WP 0232 00 Wheel and Tire Replacement	0232 00-1
WP 0233 00 Bogie Wheel Assembly Maintenance	0233 00-1

Table of Contents - Continued

	Page Number
<i>Steering</i>	
WP 0234 00 Steering Column Repair	0234 00-1
WP 0235 00 Emergency Steering Pump Replacement	0235 00-1
WP 0236 00 Steering Control Valve Replacement	0236 00-1
WP 0237 00 Steering Accumulator Replacement	0237 00-1
WP 0238 00 Steering Calibration	0238 00-1
<i>Frame</i>	
WP 0239 00 Locking Pin Bushing Replacement	0239 00-1
<i>Cab, Body and Hood</i>	
WP 0240 00 Cab Door Assembly Maintenance	0240 00-1
WP 0241 00 Windshield and Window Glass Replacement	0241 00-1
<i>Hydraulics</i>	
WP 0242 00 Tophandler and Steering Hydraulic Pump Assembly Replacement	0242 00-1
WP 0243 00 Tophandler and Steering Hydraulic Pumps Adjustment	0243 00-1
WP 0244 00 Slewing Motor Brake Replacement	0244 00-1
WP 0245 00 Spreader Maintenance	0245 00-1
WP 0246 00 Boom and Brake System Hydraulic Pump Replacement	0246 00-1
WP 0247 00 Cooling Fan Hydraulic Pump Replacement	0247 00-1
WP 0248 00 Hydraulic Cooling Fan Maintenance	0248 00-1
WP 0249 00 Main Control Valve Replacement	0249 00-1
WP 0250 00 Servo Control Valve Replacement	0250 00-1
WP 0251 00 Tophandler Control Valve Replacement	0251 00-1
WP 0252 00 Boom Lift Cylinder Replacement	0252 00-1
WP 0253 00 Boom Folding Cylinder Replacement	0253 00-1
WP 0254 00 Boom Support Locking Pin Cylinder and Locking Pin Replacement	0254 00-1
WP 0255 00 Tophandler Tilt Cylinder Replacement	0255 00-1
WP 0256 00 Tophandler Sideshifting Cylinder Replacement	0256 00-1
WP 0257 00 Tophandler Leveling Cylinder Replacement	0257 00-1
WP 0258 00 Boom Assembly Replacement	0258 00-1
WP 0259 00 Boom and Tophandler Calibration	0259 00-1
WP 0260 00 Tophandler Twistlock Replacement	0260 00-1
WP 0261 00 Forklift Cylinder Replacement	0261 00-1
WP 0262 00 Hydraulic Reservoir Replacement	0262 00-1
WP 0263 00 Hydraulic System Valve Maintenance	0263 00-1
<i>Refrigeration and Air Conditioning</i>	
WP 0264 00 Cab Heater/Air Conditioning Unit Replacement	0264 00-1
WP 0265 00 Air Conditioning System Maintenance	0265 00-1
WP 0266 00 Air Conditioner Compressor Replacement	0266 00-1
WP 0267 00 Air Conditioner Hoses Replacement	0267 00-1
WP 0268 00 Air Conditioner Condenser Replacement	0268 00-1
WP 0269 00 Air Conditioner Receiver-Dryer Replacement	0269 00-1

Table of Contents - Continued

**Page
Number**

CHAPTER 5 GENERAL SUPPORT MAINTENANCE INSTRUCTIONS

Engine

WP 0270 00	Mounting Engine On Rebuild Stand	0270 00-1
WP 0271 00	Cylinder Block Repair	0271 00-1
WP 0272 00	Crankshaft Replacement	0272 00-1
WP 0273 00	Piston and Connecting Rod Maintenance	0273 00-1
WP 0274 00	Camshaft and Drive Gear Replacement	0274 00-1
WP 0275 00	Cam Follower Assembly Maintenance	0275 00-1
WP 0276 00	Idler Gears and Camshaft Drive Gear Replacement	0276 00-1
WP 0277 00	Oil Pump Assembly Maintenance	0277 00-1
WP 0278 00	Front Gear Housing Replacement	0278 00-1
WP 0279 00	Hydraulic Cylinder Repair (Cab Lift and Sideshift)	0279 00-1
WP 0280 00	Hydraulic Cylinder Repair (Tophandler, Sideshift, Leveling, Locking Pin, and Forklift Kit)	0280 00-1

Cranes and Shovels

WP 0281 00	Boom Support Replacement	0281 00-1
WP 0282 00	Preparation for Arctic Operation	0282 00-1
WP 0283 00	Preparation for Storage or Shipment	0283 00-1
WP 0284 00	General Maintenance Instructions	0284 00-1
WP 0285 00	Illustrated List of Manufactured Items	0285 00-1
WP 0286 00	Torque Limits	0286 00-1

CHAPTER 6 SUPPORTING INFORMATION

WP 0287 00	References	0287 00-1
WP 0288 00	Maintenance Allocation Chart (MAC) Introduction	0288 00-1
WP 0289 00	Maintenance Allocation Chart (MAC)	0289 00-1
WP 0290 00	Expendable and Durable Items List	0290 00-1
WP 0291 00	Load Testing Procedure	0291 00-1
WP 0292 00	Foldouts	0292 00-1
	Index	Index-1

HOW TO USE THIS MANUAL

INTRODUCTION

1. This manual is designed to help you perform Organizational Maintenance and Troubleshooting on the RT 240 Rough Terrain Container Handler (RTCH) Army, Army RESET (hereafter "RESET"), and USMC configurations. For model-specific information, the configuration name (Army, Army RESET, or USMC) is specified in the task title in parentheses (for maintenance tasks) and in the table/errors code title in parentheses (for Troubleshooting procedures). If there is no designation, the task/troubleshooting procedure applies to all three models.
2. The *Repair Parts and Special Tools List (RPSTL)*, TM 10-3930-675-24P, is to be used in conjunction with this manual, to locate and obtain the repair parts and special tools needed to maintain this equipment.
3. This manual is written in Work Package format:
 - a. Chapters divide the manual into major categories of information (e.g., *Introductory Information with Theory of Operation, Troubleshooting Procedures, Organizational Maintenance Instructions, Direct Support Maintenance Instructions, General Support Maintenance Instructions, and Supporting Information*).
 - b. Each Chapter is divided into Work Packages, which are identified by a 6-digit number (e.g., 0001 00, 0002 00) located on the upper right-hand corner of each page. The Work Package page number (e.g., 0001 00-1, 0001 00-2) is located centered at the bottom of each page.
 - c. If a Change Package is issued to this manual, added Work Packages use the 5th and 6th digits of their number to indicate new material. For instance, Work Packages inserted between WP 0001 00 and WP 0002 00 are numbered WP 0001 01, WP 0001 02, etc.
4. This manual is published in two volumes: Volume I covers Chapters 1 and 2, Work Packages 0001 00 through WP 0048 00 and includes all troubleshooting, Chapter 6: Supporting Information is included in Volumes I and II. Volume II includes Chapters 3 through 6, WP 0049 00 through WP 0292 00.
5. Scan through this manual to become familiar with its organization and contents before attempting to maintain the equipment.

CONTENTS OF THIS MANUAL

1. A *Warning Summary* is located at the beginning of each volume of the manual. Become familiar with these warnings before operating or performing troubleshooting or maintenance on the vehicle.
2. A *Table of Contents* in Volume I lists the contents of Volumes I and II. The *Table of Contents* in Volume II lists the contents of Volume II only.
 - a. The *Table of Contents* also provides *Reporting Errors and Recommending Improvements* information and DA Form 2028 addresses, for the submittal of corrections to the manual.
 - b. If you cannot find what you are looking for in the *Table of Contents*, refer to the alphabetical *Index* at the back of the manual. The alphabetical Index for each volume lists only those Work Packages found in that volume.
3. Chapter 1, *Introductory Information with Theory of Operation*, provides general information on the manual and the equipment.
4. Chapter 2, *Troubleshooting Procedures*, contains all applicable troubleshooting and a complete listing of *Error Codes* resident on the RTCH.
 - a. Before attempting to perform troubleshooting, carefully read the information in WP 0004 00, *Troubleshooting Introduction*. It explains how to perform both non-error code and error code-driven troubleshooting. Included at the end of this Work Package are locator diagrams of all electrical and hydraulic components that may be hard to locate.
 - b. The *Troubleshooting Symptom Index* in WP 0006 00 is divided into three sections. The first is an alphabetical listing, by system, of non-error code-driven malfunctions. The second is a "Numerical Error Code Symptom Index". The third is an "Alphabetical Error Code Symptom Index".
 - c. The corrective action for certain malfunctions is to notify "SRA". Refer to Table 3 in the *Maintenance Allocation Chart MAC* (WP 0289 00) for further information about the Specialized Repair Activity for the RTCH.

CONTENTS OF THIS MANUAL - CONTINUED

5. Chapter 3 covers all *Organizational Maintenance Instructions*, Chapter 4 covers all *Direct Support Maintenance Instructions* and Chapter 5 covers all *General Support Maintenance Instructions*. In each chapter, work packages are organized in the same Functional Group Code (FGC) sequence as the MAC found in Chapter 6 of both volumes.
6. Chapter 6 includes *Supporting Information: References, MAC Introduction, MAC, Expendable and Durable Items List, Load Testing Procedure, and Foldouts of Hydraulic Systems*.
7. An alphabetical *Index* completes the manual.

FEATURES OF THIS MANUAL

1. WARNINGS, CAUTIONS, NOTES, subject headings, and other important information are highlighted in **BOLD** print as a visual aid.

WARNING

A WARNING indicates a hazard which may result in death or serious injury to personnel.

CAUTION

A CAUTION is a reminder of safety practices or directs attention to usage practices that may result in damage to equipment.

NOTE

A NOTE is a statement containing information that will make the procedures easier to perform.

2. Statements and words of particular interest may be printed in CAPITAL LETTERS to create emphasis.
3. Within a procedural step, reference may be made to another Work Package in this manual or to another manual. These references indicate where you should look for more complete information.
 - a. If you are told: "Replace engine ECU (WP 0079 00)", go to the first page of Work Package 0079 00 in Volume II of this manual for instructions on replacing the engine ECU. Be sure to read the "Initial Setup" on page 1 of the Work Package, to determine contents of Work Package as well as information regarding tools and equipment, spare parts, and personnel required, etc.
 - b. If you are told: "Check coolant level (TM 10-3930-675-10)", go to TM 10-3930-675-10-1 for the Army machine or go to the TM 10-3930-675-10-2 for the USMC or RESET machines for complete instructions on checking the coolant level. Use the *Table of Contents* or alphabetical *Index* in TM 10-3930-675-10-1 to find the procedure.
4. Illustrations are placed after, and as close to, the procedural steps to which they apply. Callouts placed on the art may be text or numbers, whichever method is easier for the soldier.
5. Numbers located at lower right corner of art (e.g., 350-001; 434-0002) are art control numbers and are used for tracking purposes. Disregard these numbers.
6. Dashed leader lines used in illustrations indicate that called out items are not visible in the view depicted (i.e., they are located within or behind the structure).
7. Technical instructions include metric units as well as standard units. For your reference, a *Metric Conversion Chart* is located on the inside back cover of the manual.

NOTE

If at any time you are unsure how to use this manual or you cannot locate the information you need, notify your supervisor.

CHAPTER 1
INTRODUCTORY INFORMATION WITH
THEORY OF OPERATION

SCOPE

1. **Type of Manual.** This manual is for use in performing Organizational Maintenance and Troubleshooting on the Rough Terrain Container Handler (RTCH), RT 240, Rough Terrain Container Handler (RTCH), RT 240 (RESET), and Rough Terrain Container Handler (RTCH), RT 240V2.
2. **Equipment Name and Model Number.** Rough Terrain Container Handler (RTCH), RT 240, Rough Terrain Container Handler (RTCH), RT 240 (RESET), and Rough Terrain Container Handler (RTCH), RT 240V2.
3. **Purpose of Equipment.** The RTCH-RT 240, RTCH-RT 240 (RESET), and RTCH-RT 240V2 are designed to lift and stack 20 and 40 ft International Standard Organization (ISO) containers, loaded to a gross weight of 53,000 lb (24,062 kg).

MAINTENANCE FORMS, RECORDS, AND REPORTS

Department of the Army forms and procedures used for the equipment will be those prescribed by DA PAM 750-8, *The Army Maintenance Management System (TAMMS) Users Manual*, as contained in the Maintenance Management Update.

REPORTING EQUIPMENT IMPROVEMENT RECOMMENDATIONS (EIR)

If your RTCH needs improvement, let us know. Send us an EIR. You, the user, are the only one who can tell us what you don't like about your equipment. Let us know why you don't like the design or performance. Put it on an SF Form 368 (*Product Quality Deficiency Report*). Mail it to us at: Commander, U.S. Army Tank-automotive and Armaments Command, ATTN: AMSTA-AC-NML, Rock Island, Illinois 61299-7630. We'll send you a reply.

CORROSION PREVENTION AND CONTROL (CPC)

1. Corrosion Prevention and Control (CPC) of Army materiel is a continuing concern. It is important that any corrosion problems with this item be reported so that the problem can be corrected and improvements can be made to prevent the problem in future items.
2. While corrosion is typically associated with rusting of metals, it can also include deterioration of other materials, such as rubber and plastic. Unusual cracking, softening, swelling, or breaking of these materials may be a corrosion problem. If a corrosion problem is identified, it can be reported using SF Form 368 (*Product Quality Deficiency Report*). Use of key words such as "corrosion," "rust," "deterioration," or "cracking" will ensure that the information is identified as a CPC problem. The form should be submitted to the address specified in DA PAM 750-8.

OZONE DEPLETING SUBSTANCES

Listing to be provided by requiring activity.

DESTRUCTION OF ARMY MATERIEL TO PREVENT ENEMY USE

For destruction of Army materiel to prevent enemy use, refer to TM 750-244-6.

PREPARATION FOR STORAGE OR SHIPMENT

For preparation for storage or shipment procedures, refer to TM 10-3930-675-24.

WARRANTY INFORMATION

The vehicles are warranted by Kalmar RT in accordance with TB 10-3930-675-24. Warranty starts on the date found in block 23, DA Form 2408-9 in the logbook. Report all defects in material or workmanship to your supervisor, who will take appropriate action through your Organizational Maintenance shop.

LIST OF ABBREVIATIONS/ACRONYMS

NOTE

Refer to ASME Y14.38-1999 for standard abbreviations.

ABBREVIATIONS/ACRONYMS	DEFINITION
AAL.....	Additional Authorization List
BII.....	Basic Issue Items
C.....	Centigrade or Celsius
CAN-BUS.....	Controller Area Network-BUS
CID.....	Cubic Inch Displacement
cm.....	Centimeter
COEI.....	Components of End Item
CPC.....	Corrosion Prevention and Control
ECM.....	Electronic Control Module
ECS.....	Electronic Control System
ECU.....	Electronic Control Units
EEPROM.....	Electrically-Erasable Programmable Read-Only Memory
F.....	Fahrenheit
FGC.....	Functional Group Code
ft.....	Feet
GCWR.....	Gross Combination Weight Rating
GVWR.....	Gross Vehicle Weight Rating
hp.....	Horsepower
IETM.....	Interactive Electronic Technical Manual
in.....	Inch
ISO.....	International Standards Organization
kg.....	Kilogram
km.....	Kilometer
kPa.....	Kilopascal
kph.....	Kilometers per Hour
kW.....	Kilowatt
L.....	Liter
lb.....	Pound
lb-ft.....	Pound Foot
lph.....	Liters per Hour
m.....	Meter
MAC.....	Maintenance Allocation Chart
mm.....	Millimeter
mph.....	Mile Per Hour
NATO.....	North Atlantic Treaty Organization
NBC.....	Nuclear Biological Chemical
Nm.....	Newton Meter
OEM.....	Original Equipment Manufacturer

LIST OF ABBREVIATIONS/ACRONYMS - CONTINUED

ABBREVIATIONS/ACRONYMS	DEFINITION
PMCS	Preventive Maintenance Checks and Services
PTO	Power Take-Off
RTCH	Rough Terrain Container Handler
SOP	Standard Operating Procedure
SPORT.....	Soldier's Portable On-System Repair Tool
SRA.....	Specialized Repair Activity
TAMMS.....	The Army Maintenance Management System
ULLS-G.....	Unit Level Logistics System - Ground
V	Volt(s)
yd.	Yard

END OF WORK PACKAGE

EQUIPMENT CHARACTERISTICS, CAPABILITIES, AND FEATURES**1. Characteristics.**

- a. The Rough Terrain Container Handler (RTCH) RT 240 is designed to lift, move, stack, or unstack 20 and 40 ft (6.10 to 12.19 m) by 8 ft (2.44 m) wide ISO containers.
- b. The RTCH-RT 240 has a lift capacity of 53,000 lb (24,040 kg) and operates on hard and/or unimproved surfaces, to include beach operations.
- c. The RTCH-RT 240 can be utilized as a forklift with an operator-installed forklift kit.

2. Capabilities and Features.**a. Capabilities.**

- (1) Container handling capabilities:
 - Stack or unstack 8 ft (2.44 m) high ISO containers stacked three (3) high with a gross weight of 53,000 lb (24,040 kg) in the first row.
 - Stack or unstack 8 ft (2.44 m) high ISO containers stacked three (3) high with a gross weight of 27,500 lb (12,474 kg) in the second row.
 - Stack or unstack 4.3 ft (1.31 m) high ISO containers stacked seven (7) high.
 - Container tophandler adjusts to 20 or 40 ft (6.10 to 12.19 m) ISO container lengths.
 - Container tophandler oscillates 7° left and right.
 - Container tophandler rotates 195° clockwise and 105° (145° for USMC) counterclockwise.
 - Container tophandler tilts 8° forward and 12° to the rear.
 - Container tophandler side shifts ± 15 in. (± 381 mm) from the center.
- (2) Forklift kit is operator-installed and attaches to the tophandler. The forklifts are adjustable from 24 in. (61 cm) center-to-center to 81.5 in. (207 cm) center-to-center. Lift capacity is 44,000 lb (19,958 kg).
- (3) Maximum speed of RTCH is 23 mph (37 kph) on level ground with NO LOAD; maximum speed on level ground LOADED is 15 mph (24 kph).
- (4) Maximum fording depth is 60 in. (1.52 m).
- (5) Operation in temperatures from -25°F (-32°C) to +125°F (+52°C), and to -40°F (-40°C) with arctic kit installed.

b. Features.

- (1) Electronically-controlled 400 hp, six-cylinder turbocharged engine.
- (2) Electronic semi-automatic shift controlled transmission with 4 ranges forward and 3 reverse. Operator selects range and ECM controls shift points.
- (3) The drive axles provide traction for 2-wheel or 4-wheel drive.
- (4) Limited slip differentials and multi-disc-wet brakes are an integral part of the axle assemblies. Multi-disc-wet brakes are hydraulically cooled to prevent overheating. Accumulators store energy for the emergency braking system.
- (5) The steering system is capable of 2-wheel, 4-wheel, crab, and emergency modes of operation.
- (6) The parking brake is hydraulically released and spring-applied by disc brake assemblies mounted on the front and rear differentials.
- (7) The operator's cab has a fully adjustable operator's seat, fresh air (filtered) ventilation system, and heater/defroster/air conditioning systems.

EQUIPMENT CHARACTERISTICS, CAPABILITIES, AND FEATURES - CONTINUED

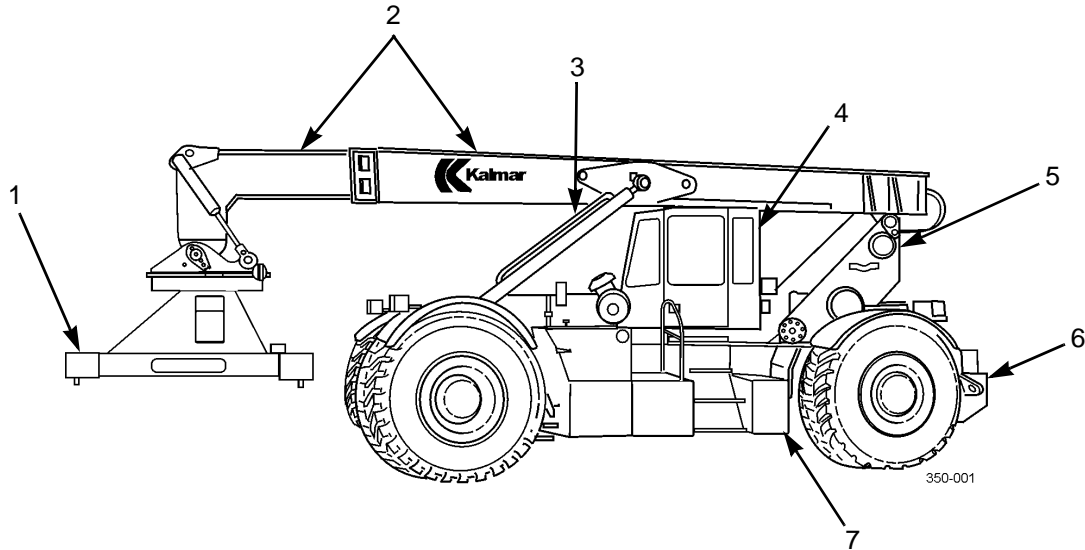
- (8) Operator's controls include: adjustable steering wheel; accelerator and brake pedals; transmission range selector; steering mode selection rocker switches; and a single joystick control for all boom, tophandler, and forklift operations.

c. Transport Modes.**NOTE**

Refer to TM 10-3930-675-10 for detailed instructions to prepare the RTCH for transport.

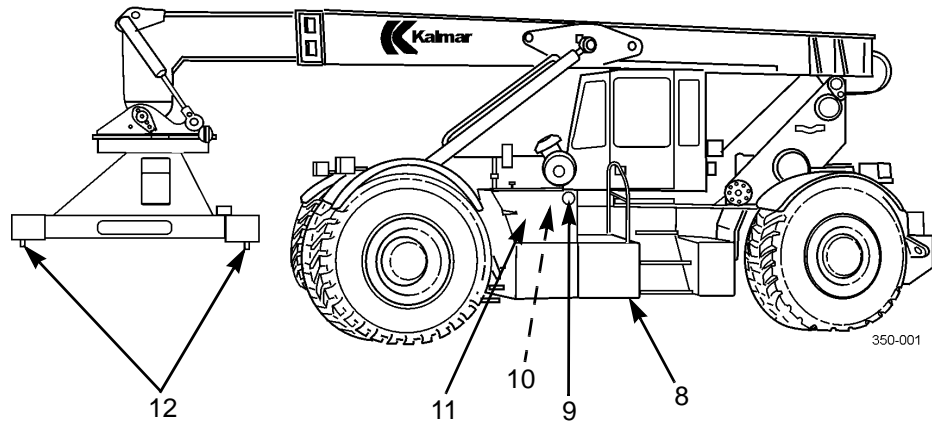
- **Self Deployment**
- **Highway Transport**
- **Rail Transport**
- **Marine Transport**
- **Air Transport**

LOCATION AND DESCRIPTION OF MAJOR COMPONENTS



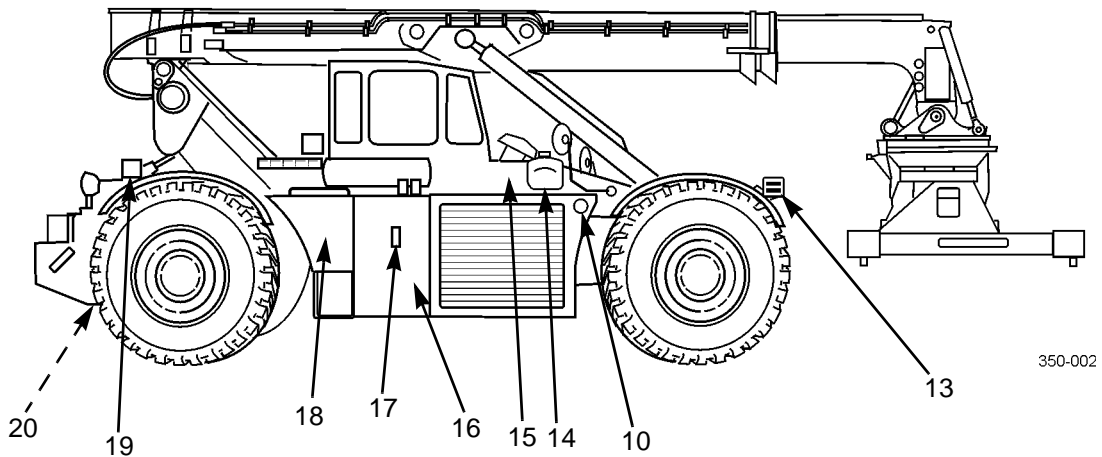
KEY	COMPONENT	DESCRIPTION
1	Tophandler	Electro-hydraulically operated 20 to 40 ft (6.10 to 12.19 m) tophandler. Capable of sideshifting, rotation, forward/rear tilting, left/right tilting, and load position leveling and locking. Also interfaces with forklift attachment.
2	Boom Assembly	Electro-hydraulically operated heavy duty steel boom designed for moving, lifting, and stacking 20 to 40 ft (6.10 to 12.19 m) ISO containers.
3	Boom Lift Cylinders	Electro-hydraulically operated cylinders raise, lower, and support the boom assembly.
4	Operator's Cab	Contains all driving and container handling controls as well as heating, air conditioning, and filtered ventilation system controls. During air transport operations, the cab is moved to the left side of the chassis, then lowered and secured in place.
5	Boom Support	Rear support and pivot point for the boom to include an unlocking device that allows the boom assembly to be lowered into the transport position.
6	Frame	A heavy-duty steel construction with tie-downs, towing lugs, and pintle hook.
7	Remote Hydraulic Control Compartment	Location of selected hydraulic remote controls. Also access to hydraulic system test and sampling ports.

LOCATION AND DESCRIPTION OF MAJOR COMPONENTS - CONTINUED



KEY	COMPONENT	DESCRIPTION
8	Dolly Wheels Storage Compartment	Storage location for the attachable tophandler air transport dolly wheels.
9	Master Battery Switch	ON/OFF control of electrical power from batteries to vehicle electrical system.
10	Slave Receptacle	Provides an electrical connection for slave starting. A receptacle is located on each side of the RTCH.
11	Battery Compartment	Stores four 12V batteries and required cabling. Batteries are accessible from the side and/or the top.
12	Twistlocks	Electro-hydraulically operated and monitored ISO twistlocks, located at each corner of the tophandler. Also utilized to attach forklift attachment to tophandler.

LOCATION AND DESCRIPTION OF MAJOR COMPONENTS - CONTINUED



KEY	COMPONENT	DESCRIPTION
13	Front Service and Blackout Lights	Headlight, blackout drive light, and composite turn signal with blackout markers.
14	Coolant Expansion Tank	Contains cooling system overflow. Provides means to visually check coolant level and add coolant to system.
15	Engine Compartment	Houses the six-cylinder turbocharged diesel engine that supplies power for the automotive, electrical, and hydraulic systems.
16	Hydraulic Reservoir	Stores and vents system hydraulic oil.
17	Hydraulic Reservoir Sight Gage	Visual indicator of hydraulic oil level. If oil is NOT visible in sight gage with boom completely lowered and tophandler retracted, DO NOT start engine.
18	Fuel Tank	Stores fuel supply for vehicle.
19	Rear Service and Blackout Lights	Composite tail, stop, and blackout markers; turn signals; and backup lights.
20	Bogie Wheels	Allow weight of machine to be distributed over more wheel area during aircraft loading and transport.

EQUIPMENT DESCRIPTION AND DATA - CONTINUED

0002 00

EQUIPMENT DATA

Engine:

Manufacturer Cummins
 Model QSM 11
 Horsepower @ 2,150 RPM 400 hp (298 kW)
 Torque @ 1,200 RPM 1,450 lb-ft (1,966 Nm)
 Cylinders 6
 Displacement 661 CID (10.8 L)
 Weight 2,070 lb (940 kg)
 Fuel System Fully electronic
 Cooling System, Thermostat Range. 180° to 200°F (82° to 93°C)

Transmission:

Manufacturer ZF-Hydromedia
 Model 4 WG-260
 Type 4 forward and 3 reverse speeds
 Range Selection Automatic, electronically controlled

Axles:

Manufacturer Kessler
 Model:
 Front LT102PL341/528NLB4650
 Rear LT102PL341/528NLB4460
 Weight:
 Front 8,379 lb (3,800 kg)
 Rear 5,733 lb (2,600 kg)

Tires:

Front and Rear:
 Manufacturer Bridgestone
 Size 29.5 R 35 VRL
 Inflation 85 psi (586 kPa)
 Weight 2,315 lb (1,050 kg)
 Bogie Wheels (Transport Operations):
 Manufacturer Michelin
 Size 355/65 R 15 XZM
 Inflation 85 psi (586 kPa)
 Dolly Wheels (Tophandler Transport):
 Manufacturer Michelin
 Size 225/75 R 10 XZR
 Inflation 85 psi (586 kPa)

Dimensions:

Length:
 Tophandler Lateral 37.7 ft (11.5 m)
 Tophandler Longitudinal 49.2 ft (15.0 m)
 Height:
 Operational w/Boom Level 13.1 ft (4.0 m)
 Highway Transport Mode 9.8 ft (3.0 m)
 Width, Tophandler Longitudinal 12 ft (3.6 m)

EQUIPMENT DESCRIPTION AND DATA - CONTINUED

0002 00

EQUIPMENT DATA - CONTINUED

Weights:

GVWR 118,000 lb (53,523 kg)
 GVWR w/Forklift Kit 128,400 lb (58,294 kg)

Capacities:

Fuel Tank 103 gal. (390 L)
 Cooling System 23.7 gal. (90.1 L)
 Cooling, Engine Only 3.4 gal. (12.9 L)
 Hydraulic Oil Reservoir 180 gal. (680 L)
 Engine Crankcase w/Filter 38.6 qt (36.5 L)
 Transmission w/Filter 36 qt (34 L)

Electrical System:

Type 24V, negative ground
 Batteries:
 Quantity 4
 Voltage 12V

Miscellaneous:

Maximum Lifting Capacity:
 First Stacking Row 53,000 lb (24,040 kg)
 Second Stacking Row 27,500 lb (12,474 kg)
 Maximum Lift Height 33 ft (10.06 m)
 Maximum Lifting Capacity, w/Forklift Kit
 First Stacking Row 44,000 lb (19,958 kg)
 Second Stacking Row 24,600 lb (11,158 kg)
 Maximum Lift Height, w/Forklift Kit 21.8 ft (6.65 m)
 Forklift Kit, Fork Tines Center-to-Center Range 24 to 81.5 in. (61 to 207 cm)
 Maximum Forward Reach (Boom Level) 20.6 ft (6.28 m)
 Curb-to-Curb Turning Circle:
 Four-Wheel Steering 65 ft (19.8 m)
 Ground Clearance 18 in. (45.7 cm)
 Fording Depth 60 in. (1.5 m)
 Maximum Travel Speeds:
 Empty 23 mph (37 kph)
 Loaded 15 mph (24 kph)

END OF WORK PACKAGE

INTRODUCTION

1. The RTCH-RT 240 consists of the following major components and functional systems: drive train, fuel system, exhaust system, cooling system, electrical and electronic systems, steering and brake systems, hydraulic system, cab system, and lifting boom with tophandler. A forklift kit may be added as required.
2. This work package explains how the components and systems of the RT 240 work together. A functional description is provided for each major component and system.

DRIVE TRAIN

1. The engine is a six-cylinder turbocharged diesel which supplies power to the transmission. The engine cooling system is pressurized and includes a thermostat, controlled bypass, and coolant expansion tank. Engine lubrication is pressurized and full-flow filters continuously clean oil.
2. The transmission is a semi-automatic electronically-controlled unit. The operator electronically selects range of gears and the transmission electronic control module (ECM) controls shift points up to the highest selected gear. A shift inhibitor circuit controls downshifts in forward and reverse gears. The transmission can be manually or electronically shifted through 4 forward and 3 reverse gears. A torque converter provides interface to the engine.
3. The driveshafts transmit rotation of the transmission output to the front and rear axles. Connections at both ends are made through universal joints to compensate for any misalignment due to operating on uneven surfaces.
4. The front and rear axles are identical in operating principles. Both axles are hydraulically steered with planetary wheel ends and wet-disc brakes. The rear axle oscillates above and below horizontal to allow for operation on uneven surfaces.

FUEL SYSTEM

1. Fuel to power the engine is pumped from the fuel tank by a fuel transfer pump to the electronically controlled fuel injector nozzles.
2. The engine ECM manages, monitors, and stores key engine functions, to include engine idle speed, limits maximum engine speed, and engine diagnostic data.
3. The engine-mounted fuel/water separator is a spin-on replaceable type with drain.

EXHAUST SYSTEM

The exhaust system removes exhaust gases from the engine through the exhaust manifold and turbocharger. The gases flow into exhaust pipes and muffler to the atmosphere along the right side and to the rear of the operator's cab.

COOLING SYSTEM

1. The cooling system consists of an engine-mounted circulating pump, 180° to 200°F (82° to 93°C) thermostat, oil cooler/aftercooler manifolds, a radiator, engine-mounted coolant filter, and hydraulically-driven cooling fan.
2. The cooling system cools the engine by means of circulating pressurized ethylene glycol-based coolant through the engine and radiator.

ELECTRICAL SYSTEM

1. The system voltage is 24V. Four 12V batteries, connected in series-parallel and charged by an alternator across electronic rectifying and voltage stabilization circuits, provide the voltage.
2. The negative and positive poles are both connected across the master battery switch. The negative pole is connected to the chassis.
3. NATO slave-starting receptacles are provided.

STEERING SYSTEM

1. The electro-hydraulic steering system provides three modes of steering control: 2-wheel steer, 4-wheel steer, and crab steer.
2. The variable rate steering system utilizes two front and two rear hydraulic steering cylinders and electronic wheel position sensors connected to an ECM to maintain direction and control. The variable rate system allows the system to change or adjust to different modes of operation.
3. An emergency steering pump is provided in the event the engine is inoperative. If the engine quits while operating the RTCH, the emergency steering pump provides sufficient hydraulic pressure to control the truck until it is brought to a safe stop.

BRAKE SYSTEM

1. The brakes are totally enclosed within the front and rear drive axle housings, next to the wheel ends.
2. The brake system is a wet brake system that is comprised of three separate hydraulic circuits: service brake circuit, cooling circuit, and parking brake circuit.
3. The brake system also includes six pressurized accumulators that provide adequate stored energy to stop the RTCH in the event of engine shutdown.
4. The service brake circuit is applied by depressing either the left or right floor-mounted hydraulic brake pedals. Brake pressure is applied to eight cylinders per side within the front axle and one cylinder per side in the rear axle.
5. The brake system cooling circuit cools the brake disks using oil pumped from the main hydraulic system through brake chambers during operation.
6. The parking brake assemblies are mounted at the input flanges of the front and rear axles. The brakes are applied by spring pressure and released hydraulically. A warning buzzer sounds if the driver leaves the seat without applying the parking brakes. The parking brake should never be applied as an emergency brake or while the vehicle is moving. Application of the parking brake while the vehicle is moving can result in major drive train damage.

HYDRAULIC SYSTEM

The RTCH hydraulic system is comprised of the following major components that provide hydraulic power to operate and control the container tophandler, boom, steering, and brake systems. In addition the hydraulic system is used to place the cab and bogie wheels into transport mode.

1. Three variable piston-type hydraulic pumps are driven by the transmission power take-off (PTO). The pumps provide hydraulics for the steering system and tophandler.
2. One double vane-type pump is driven by the transmission PTO. It provides hydraulics for the boom cylinders, service, and parking brake systems.
3. One single-vane pump is driven by the engine. It provides hydraulics for a cooling fan.
4. Main valves control the main hydraulics. The valves are controlled by an electro-hydraulic servo system from the joystick control in the operator's cab.
5. High-pressure oil filters clean hydraulic oil before returning oil to the reservoir. Breather filters allow venting of the hydraulic reservoir.
6. Hydraulic system oil cooler and fan maintain and control hydraulic oil temperature. The cooling fan is powered by hydraulics from an engine-driven hydraulic pump.
7. Emergency systems: one ground-driven hydraulic pump maintains steering control in the event of engine failure; a 24V electric hydraulic pump provides power to lower boom and release the twist locks in the event of engine failure. The electric pump also provides a means to place the operator's cab into the transport mode.

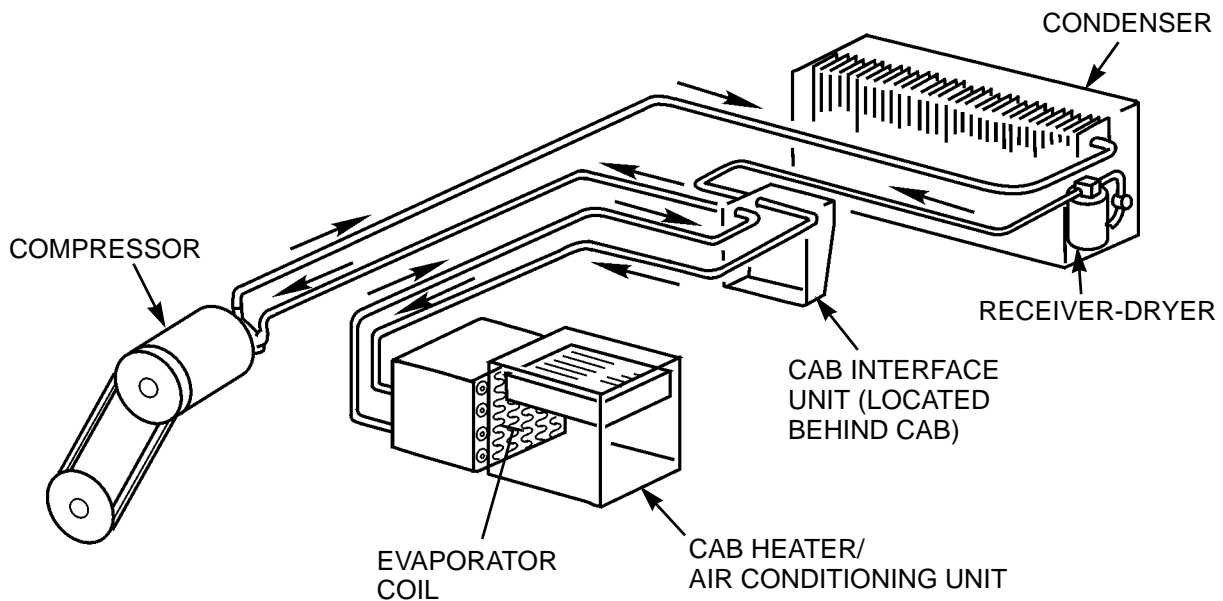
CAB SYSTEM

The operator's cab is a sound and weather insulated unit that provides the operator with the systems to control and monitor both standard automotive functions and container handling functions. The following components or systems are also contained within the cab:

1. Adjustable steering column and adjustable suspension seat.
2. Heater, air conditioning, and filtered ventilation system.
3. Portable fire extinguisher and rifle mount.

AIR CONDITIONING SYSTEM

1. The air conditioning system unit is part of the heater and is mounted at the front of the cab. It is a single unit consisting of a heater core, air conditioning evaporator coil, blower motor, control valves, and air ducts.
2. The system is turned on by the air conditioning control switch on the instrument panel in the cab. The two-speed blower switch controls flow rate.
3. An even cab temperature is maintained by using the air conditioner temperature control switch to control the refrigerant flow through the evaporator coil.



350-1021

ELECTRONIC SYSTEM

The RTCH-RT 240 is equipped with several electronic modules, all connected using CAN-BUS technology. The modules can be diagnosed using the OEM testing equipment. They assist in the operation of major systems such as engine, transmission shifting, steering mode and wheel position, the safe working load control, and many related functions that require data input to operate correctly for the intended uses of the RTCH-RT 240.

LIFTING BOOM AND TOPHANDLER

The lifting boom and tophandler is an electro-hydraulic operated heavy-duty telescoping boom and spreader assembly, designed to lift, move, and stack/unstack 20 to 40 ft (6.10 to 12.19 m) ISO containers. The operator joystick provides complete control of the lifting boom and tophandler during container handling operations. The boom provides lifting/lowering, extending/retracting operations. The tophandler or spreader provides for sideshifting, rotation, forward/rear tilting, left/right tilting, and load leveling and locking operations. The tophandler also provides interface capability with a forklift attachment.

FORKLIFT KIT

The forklift kit is attached to the tophandler twistlocks and two hydraulic hose quick-disconnects. Forklift operation is controlled from the tophandler joystick to include adjustable forktines. The forktines and vertical support beams fold under the forklift framework for transport.

END OF WORK PACKAGE

CHAPTER 2
TROUBLESHOOTING PROCEDURES

GENERAL

1. The RTCH-RT 240 has an extensive on-board diagnostic capability that enables the user to isolate faults based on error codes. This diagnostic capability, when used in conjunction with traditional troubleshooting techniques, enables the user to fault isolate most malfunctions that will occur on the RTCH.
2. This chapter provides information for identifying and correcting malfunctions which may develop while operating the RTCH. Both error code and non-error code troubleshooting are contained within this chapter.
 - a. Work Package 0007 00 addresses non-error code troubleshooting.
 - b. Work Packages 0008 00 through 0047 00 address error code troubleshooting.
3. The Troubleshooting Symptom Indexes in WP 0006 00 list common malfunctions which may occur (non-error code malfunctions and electronically-identified error codes) and refer you to the proper work package for a troubleshooting procedure. Three separate indexes are provided as an aid to the user:
 - a. *Non-Error Code Symptom Index*. This index is organized alphabetically by functional group/system. Symptoms within each functional group/system are listed in alphabetical order. The page number listed in the Troubleshooting Procedure Page column takes you directly to the troubleshooting task.
 - b. *Alphabetical Error Code Symptom Index*. This index lists the functional group/system in alphabetical order. Error codes underneath each system are listed in ascending numeric order. The page number listed in the Troubleshooting Procedure Page column takes you to the first page of the work package, so that initial setup data can be reviewed prior to starting the specific troubleshooting task.
 - c. *Numerical Error Code Symptom Index*. This index lists all error codes in ascending numeric order. Since certain error codes are present within multiple systems, a column has been added that identifies the functional group/system that is impacted by the error code. For example, Error Code 130 is listed for 6 different systems. You will need to know in which system (e.g., Boom In/Out or Tophandler Slewing) the error occurred before you can determine which work package you'll need.
4. It is not possible to list all malfunctions that may occur, nor all tests or inspections and corrective actions. If a malfunction is not listed, or is not corrected by the listed corrective actions, notify your supervisor.
5. If you are unsure of the location of an item mentioned in troubleshooting, refer to WP 0002 00. This work package identifies the major components on the RTCH.
6. Figures 1 thru 13, at the end of this work package, illustrate electrical and hydraulic components that may be difficult to find during the troubleshooting process.
7. As an aid to the user, electrical diagrams are contained in WP 0048 00. Each troubleshooting procedure references you to the diagram in WP 0048 00 that applies to your particular troubleshooting task.
8. Before performing troubleshooting, read and follow all safety instructions found in the *Warning Summary* at the front of this manual.

PRELIMINARY TROUBLESHOOTING PROCEDURES**NOTE****Fluid leaks are classified as either Class I, Class II, or Class III**

Class I: See page of fluid (as indicated by wetness or discoloration) not great enough to form drops.

Class II: Leakage of fluid great enough to form drops, but not enough to cause drops to drip from item being checked/inspected.

Class III: Leakage of fluid great enough to form drops that fall from item being checked/inspected.

1. Before starting any specific troubleshooting procedures, perform the following tasks:
 - a. Visually check for ruptured oil, fuel, or hydraulic lines and for Class II or Class III leaks.

PRELIMINARY TROUBLESHOOTING PROCEDURES - CONTINUED

- b. Check for mechanical jamming or binding caused by rocks or other foreign matter.
- c. Check fluid levels in subject area and service as required (TM 10-3930-675-10 or WP 0050 00 in this manual).
2. Ensure all applicable Operator Troubleshooting has been performed before proceeding.

EXPLANATION OF TROUBLESHOOTING TABLE COLUMNS

The columns in troubleshooting tables are defined as follows:

1. **MALFUNCTION**. Indicates fault that has occurred in system/equipment.
2. **TEST OR INSPECTION**. Indicates test or inspection to be performed to isolate probable cause for fault symptom.
3. **CORRECTIVE ACTION**. Indicates procedure to correct the problem.

GENERAL ELECTRICAL INFORMATION - ERROR CODE AND NON-ERROR CODE TROUBLESHOOTING**NOTE**

Refer to *Electrical General Maintenance Instructions (WP 0113 00)* for instructions on using a multimeter to check for continuity or shorts and to perform voltage checks.

1. Analyze the symptoms and conditions and use common sense and logic to determine the most likely cause for the problem, then troubleshoot that circuit first. The more information you have concerning the problem, the easier it will be to troubleshoot.
2. Isolate to the subsystem level (in cases where more than one subsystem is involved); next isolate the problem to a single circuit within the subsystem; then, isolate the problem to the faulty component using the *Troubleshooting Symptom Index* (WP 0006 00).
3. Frayed, broken, loose, or corroded wiring is a common source of problems in any electrical circuit. Always make visual inspection before starting detailed troubleshooting. Observe in particular contacts to ground. Components with case grounds are especially troublesome.

CAUTION

- **DO NOT use test lights or non-digital multimeters to troubleshoot the RTCH. Only digital multimeters may be used. Failure to follow this caution may damage electronic components.**
 - **When making continuity checks, make sure test equipment is isolated from power source.**
4. Most of the checks are made by voltage checks. Pay particular attention to the voltages being checked in the procedures. This equipment has a combination of 12V and 24V systems. Instructions prior to the step instruct to disconnect at test point from the potential malfunctioning component. Once the check has been made, either repair the component or go to the referenced step. If going to another step, reconnect connection or do as otherwise instructed, such as install and use jumper wires. When ready to make the prescribed check, apply power to the circuit (if required). A helper may be required if the switch or power source is out of reach. Release the power function prior to going on, to avoid damage to equipment.

NON-ERROR CODE TROUBLESHOOTING

Even though the RTCH has on-board diagnostics, not all malfunctions will produce error codes. Use non-error code troubleshooting when no error code is generated, yet the RTCH is not functioning properly. When troubleshooting a non-error code type malfunction:

1. Perform *Preliminary Troubleshooting Procedures*. If this doesn't solve the problem, go to step 2.
2. Locate the symptom or symptoms in WP 0006 00 that best describe the malfunction.

NON-ERROR CODE TROUBLESHOOTING - CONTINUED

3. Turn to the page in WP 0007 00 where the troubleshooting procedures for the malfunction in question are described. Headings at the top of each troubleshooting table show how each troubleshooting procedure is organized: MALFUNCTION, TEST OR INSPECTION, and CORRECTIVE ACTION.
4. Perform each step in the order listed until the malfunction is corrected. DO NOT perform any maintenance task unless the troubleshooting procedure tells you to do so.
5. If the problem is still not corrected, access the Diagnostic Menu to see if any additional information might be available.

ERROR CODE TROUBLESHOOTING

1. The RTCH has six (6) Electronic Control Units (ECUs) that are at the heart of the on-board diagnostic system. The location of each computer ECU is identified in Table 1 and in Figures 1 and 2 at the end of this work package.
2. The driver's Electronic Control System (ECS) screen displays error codes based on data collected from each of the other computers. Refer to *Explanation of Error Code Display* in this work package for more information on how to read this display.
3. WP 0005 00, *Error Codes*, provides a complete listing of the error codes visible to both the operator and maintainers of the RTCH.
4. While performing troubleshooting, it may be necessary to access the system Diagnostic, Calibration, or Initialization Menus. As a maintainer of the RTCH, you are authorized to access these menus as part of the troubleshooting process. These menus, which are not normally available to the operator, provide additional information that will help you diagnose a problem.
 - a. *Diagnostic Menu, Access Code 12443* (Table 2). Many of the error code troubleshooting procedures will direct you to use this menu as part of the troubleshooting task. To access the Diagnostic Menu:
 - (1) Turn ON ignition switch, but do not start engine unless required to do so to accomplish the troubleshooting procedure.
 - (2) Using left or right arrows on operator's control panel, scroll through operational screens, stopping at the Kalmar maintenance icon (TM 10-3930-675-10). Press "Enter".
 - (3) Enter access code "12443".
 - (4) To select DIAG SERVO menu, press "Enter". Use arrow keys to scroll through menu. Press "Enter" at end of each menu to return to main menu.
 - (5) Press right arrow key to scroll to additional DIAG menus:
 - (a) DIAG ATTACHMENT (Tophandler)
 - (b) DIAG STEERING
 - (c) DIAG GEARBOX (Transmission)
 - (d) DIAG ENGINE
 - (e) DIAG EXTRA FUNC
 - (6) For a more detailed explanation, refer to Exhibit 1, Diagnostic Menus, on page 9 in this work package which provides normal value ranges for the function.
 - (7) Use right or left arrow keys to scroll through each menu. Press "Enter" at end of each menu to return to main menu.
 - b. *Calibration Menu, Access Code 13221* (Table 3). Some of the troubleshooting procedures direct you to calibrate the steering, boom with tophandler, or transmission. The calibration menu identifies calibration requirements for these systems. Additionally, there are specific calibration procedures in Chapter 4 that address the calibration requirements for these three items. To access the Calibration Menu:
 - (1) Turn ON ignition switch, but do not start engine unless required to do so to accomplish the troubleshooting procedure.

ERROR CODE TROUBLESHOOTING - CONTINUED

- (2) Using left or right arrows on operator’s control panel, scroll through operational screens, stopping at the Kalmar maintenance icon (TM 10-3930-675-10). Press “Enter”.
 - (3) Enter access code “13221”.
 - (4) To select CALIBR SERVO menu, press “Enter”. Use arrow keys to scroll through menu. Press “Enter” at end of each menu to return to main menu.
 - (5) Press right arrow key to scroll to additional CALIBR menus:
 - (a) CALIBR STEERING
 - (b) CALIBR GEARBOX (Transmission)
 - (6) Use right or left arrow keys to scroll through each menu. Press “Enter” at end of menu to return to main menu.
- c. *Initialization Menu, Access Code 32131* (Table 4). The initialization menu defines factory-set parameters for the RTCH. This is mostly an informational menu except for two of the menu screens. To access the Initialization Menu:
- (1) Turn ON ignition switch, but do not start engine unless required to do so to accomplish the troubleshooting procedure.
 - (2) Using the left or right arrows on operator’s control panel, scroll through operational screens, stopping at the Kalmar maintenance icon (TM 10-3930-675-10). Press “Enter”.
 - (3) Enter access code “32131”.
 - (4) Use right or left arrow keys to scroll through initialization menu. Press “Enter” at end of menu to return to main menu.

CAUTION

Do not change any of the values in screens 2(19) thru 17(19) for Army or 2(21) thru 17(21), 19(21), 20(21) for RESET/USMC. These are the factory-set parameters that regulate certain hydraulic functions. Any changed values could result in degraded hydraulic operation.

- (5) Screen 1(19) for **ARMY** or 1(21) for **RESET/USMC** is used to set the units for the operator display screen. Use the + or - key to change the value. Press “Enter” to save the change 0 = Metric and 1 = US.
- (6) Screen 18(19) for **ARMY** or 18(21) for **RESET/USMC** is used to activate information type error codes that have been deactivated in the operator ECS display screens. Use the + or - key to change the value. Press “Enter” to save the change. 0 = activated and 1 = deactivated.

Table 1. Location of Electronic Control Units (ECUs).

ECU NAME	ECU NUMBER	DIAGRAM NUMBER	LOCATION
Hydraulic Servo	790	A34648.0200	Under driver’s seat
Tophandler	791	A34652.0200	Forward end of boom
Steering System	792	A34651.0200	Inside cab behind right-rear panel
Transmission	793	A34650.0200	Inside cab behind right-rear panel
Engine	794	A34649.0200	Left side of engine
ECS Display Screen	795	A34647.0200	Driver’s control panel

Table 2. Diagnostic Menu, Access Code 12443.

DIAG SERVO	DIAG ATTACHMENT	DIAG STEERING	DIAG GEARBOX	DIAG ENGINE	DIAG EXTRA FUNCT.
790	791	792	793	794	MISC
DIAG SERVO 1(13) SYSTEM POWER 24.00V POWER RI CAN 24.00V POWER LE CAN 24.00V 10V REF OUT 10.00V	DIAG ATTACHMENT 1(16) SYSTEM POWER 24.00V POWER RI CAN 24.00V POWER LE CAN 24.00V 10V REF OUT 10.00V	DIAG STEERING 1(16) DIG IN STEERING 2WD 0 STEERING 4WD 0 STEERING CRAB 0	DIAG GEARBOX 1(12) SPEED: 0mph 0kph ENGINE 0rpm OUTPUT SHAFT 0rpm	DIAG ENGINE 1(5) DEMAND TORQUE 0 ACTUAL TORQUE 0 ENGINE SPEED 0rpm	EXTRA FUNCT. 1(13) SET ENGINE SPEED 0 TO 1000rpm (+/-)
DIAG SERVO 2(13) OVER RIDE 0 TWIST LOCK 0	DIAG ATTACHMENT 2(16) TILT ANGLE 5.00V	DIAG STEERING 2(16) ERROR CODE 255 FROM 792, STEERING	DIAG GEARBOX 2(12) ERROR CODE (HEX) 0 FROM 793, GEARBOX	DIAG ENGINE 2(5) ENGINE SPEED 0rpm (+) INCREASE (-) INCREASE	EXTRA FUNCT. 2(13) CUT OFF THE 0 THE HYDRAULIC PUMP (+/-) 0rpm
DIAG SERVO 3(13) SIDE SHIFT RI 0 SIDE SHIFT LE 0 VERTICAL LIFT 0	DIAG ATTACHMENT 3(16) ALIGNMENT LE FRONT0 RI FRONT0 LE REAR 0 RI REAR 0	DIAG STEERING 3(16) GE REQ. PROGRAM 0 0:2WD 1:4WD 2:CRAB 3:EMERGENC	DIAG GEARBOX 3(12) AR PROGRAM 0:2WD 1:4WD 2:CRAB 3:MANUAL	DIAG ENGINE 3(5) ENGINE OIL TEMP 0grc COOLANT TEMP 0grc INTAKE MAN.TEMP 0grc	EXTRA FUNCT. 3(13) EL HYD. PUMP INPUT 0 EL HYD. PUMP OUTPUT 0
DIAG SERVO 4(13) LOCK TILT 0 LOCK OSCILLATE 0	DIAG ATTACHMENT 4(16) TWIST LOCK LE UNL. 1 RI UNL. 1 LE LOCK 0 RI LOCK 0	DIAG STEERING 4(16) EME.OPERATION MODE 0 STEER.PROG CHANGE 0 NEUTRAL GEAR STAT. 0	DIAG GEARBOX 4(12) SHIFT LEVER POSITION: FORWARD 0 NEUTRAL 1 REVERS 0	DIAG ENGINE 4(5) OIL PRESSURE 0bar BOOST PRESS. 0bar	EXTRA FUNCT. 4(13) WATER LEVEL 0 (0=CUT OFF FAN)
DIAG SERVO 5(13) LIFT/LOWER 5.00V BOOM IN/OUT 5.00V	DIAG ATTACHMENT 5(16) ROTATION -/+ 45 - DAMPING 20/40 0 ATTACHMENT SIG 1 1 ATTACHMENT SIG 2 1	DIAG STEERING 5(16) PRESSUR SW. STAT 0 SUPPLY PRESSUR 0	DIAG GEARBOX 5(12) SH.POSITION RANGE 3 DRIVE LINE ENGANGE 0	DIAG ENGINE 5(5) DIAGNOSIS OF ENGINE DONE ENTER	EXTRA FUNCT. 5(13) BLACKOUT 0 WORK. LIGHT ATTACH. 0
DIAG SERVO 6(13) SLEW CW/CCW 5.00V TILT IN/OUT 5.00V	DIAG ATTACHMENT 6(16) TW-LOCK OUTPUT INPUT UNLOCKED 0.00V 0mA LOCKED 0.00V 0mA	DIAG STEERING 6(16) ERROR STATUS AXLE 1:0 AXLE 2:0 AXLE 3:0 AXLE 4:0	DIAG GEARBOX 6(12) OIL TEMP 0grc OIL TEMP SUMP 0grc	ARMY ONLY	EXTRA FUNCT. 6(13) HYD.FILTER 300K 0 HYD.FILTER STEERING 0 HYD.FILTER ATTACH. 0 HYD.FILTER RET.OIL 0
DIAG SERVO 7(13) LENGTH SENSOR 1.00V ANGLE SENSOR 1.50V	DIAG ATTACHMENT 7(16) SIDE SH.OUTPUT INPUT LEFT 0.00V 0mA RIGHT 0.00V 0mA	DIAG STEERING 7(16) STEERING WHEEL SIG LE 0 RI 0	DIAG GEARBOX 7(12) ACTUALE DIRECTION: FORWARD 0 NEUTRAL 1 REVERS (REV. LAMP) 0		EXTRA FUNCT. 7(13) BRAKE CIRCUIT 1 0 BRAKE CURCUIT 2 0
DIAG SERVO 8(13) PRESS RETURN 2.00V 1.50V PRESS RI 2.00V 1.50V PRESS LE 2.00V 1.50V	DIAG ATTACHMENT 8(16) OUTPUT INPUT 20'->40' 0mA 0mA 40'->20' 0mA 0mA	DIAG STEERING 8(16) RI FRONT WHEEL ANGLE SIGNAL 1 0 SIGNAL 2 0	DIAG GEARBOX 8(12) ACTUAL GEAR 0 LIMIT TO 1:ST GEAR 0 0=2WD 1=4WD 0		EXTRA FUNCT. 8(13) ETER START OK 0 CABIN OP. POS. 0 CABIN SIDE POS. 0
DIAG SERVO 9(13) OUTPUT INPUT LIFT 0mA 0mA LOWER 0mA 0mA	DIAG ATTACHMENT 9(16) LAMPS OUTPUT INPUT WORKING LIGHT 0.00V WORKING LST 'R 0.00V 3998R / 7364 onLy	DIAG STEERING 9(16) RI REAR WHEEL ANGLE SIGNAL 1 0 SIGNAL 2 0	DIAG GEARBOX 9(12) GEARBOX MODE: NORMAL 1 SUBST. CLUTCH CONT. 0 LIMP HOME 0		EXTRA FUNCT. 9(13) Rx 792, STEERING 0 Rx 793, GEARBOX 0 Rx 794, ENGINE 0
DIAG SERVO 10(13) OUTPUT INPUT BOOM IN 0mA 0mA BOOM OUT 0mA 0mA	DIAG ATTACHMENT10(16) IND.LAMP OUTPUT INPUT TW UNLOCKED 24.00V TW LOCKED 0.00V	DIAG STEERING 10(16) LE REAR WHEEL ANGLE SIGNAL 1 0 SIGNAL 2 0	DIAG GEARBOX 10(12) TRANS. SHUTDOWN 0 TCU SHUTDOWN 0 SHIFT IN PROGRESS 0	ARMY ONLY RESET/USMC	EXTRA FUNCT. 10(13) ACT. SPEED CONTROL 0 MAX RPM 0 SET OUTPUT SIG CENTRAL LUB (-/-) 0
DIAG SERVO 11(13) OUTPUT INPUT FAN 0mA 0mA BL.VALVE 0.00V 0mA	DIAG ATTACHMENT11(16) IND.LAMP OUTPUT INPUT ALIGNMENT 0.00V	DIAG STEERING 11(16) LE FRONT WHEEL ANGLE SIGNAL 1 0 SIGNAL 2 0	DIAG GEARBOX 11(12) P-BRAKE 0 INCHING 0 STEERING SYST. OK 0		EXTRA FUNCT. 11(13) INTAKE TEMP 23 FAN COOLANT TEMP 43 SPD GEARBOX TEMP 52 33 HYD OIL TEMP 55
DIAG SERVO 12(13) VALVES OUTPUT INPUT ATTACH. 0.00V 0mA PUMP OFF 0.00V 0mA	DIAG ATTACHMENT12(16) OUTPUT INPUT SLEW CW 0mA 0mA SLEW CCW 0mA 0mA	DIAG STEERING 12(16) RI FRONT WHEEL SOLENOID CW 0 SOLENOID CCW 0	DIAG GEARBOX 12(12) DIAGNOSIS OF GEARBOX DONE ENTER		EXTRA FUNCT. 12(13) WHEEL END FRONT 50 WHEEL END REAR 51 HYD TANK 40 BRAKE COOLING 1
DIAG SERVO 13(13) DIAGNOSIS OF EL.SERVO DONE ENTER	DIAG ATTACHMENT13(16) OUTPUT INPUT TILT IN 0mA 0mA TILT OUT 0mA 0mA	DIAG STEERING 13(16) RI REAR WHEEL SOLENOID CW 0 SOLENOID CCW 0			EXTRA FUNCT. 13(13) DIAGNOSIS OF EXTRA FUNCT. DONE ENTER
	DIAG ATTACHMENT14(16) OUTPUT INPUT OSC. RI 0mA 0mA OSC. LE 0mA 0mA	DIAG STEERING 14(16) LE REAR WHEEL SOLENOID CW 0 SOLENOID CCW 0			
	DIAG ATTACHMENT15(16) ACTIVE OUTPUT INPUT OSC. 24.00V 900mA TILT 24.00V 900mA	DIAG STEERING 15(16) LE FRONT WHEEL SOLENOID CW 0 SOLENOID CCW 0			
	DIAG ATTACHMENT16(16) DIAGNOSIS OF ATTACHMENT DONE ENTER	DIAG STEERING 16(16) DIAGNOSIS OF STEERING DONE ENTER			

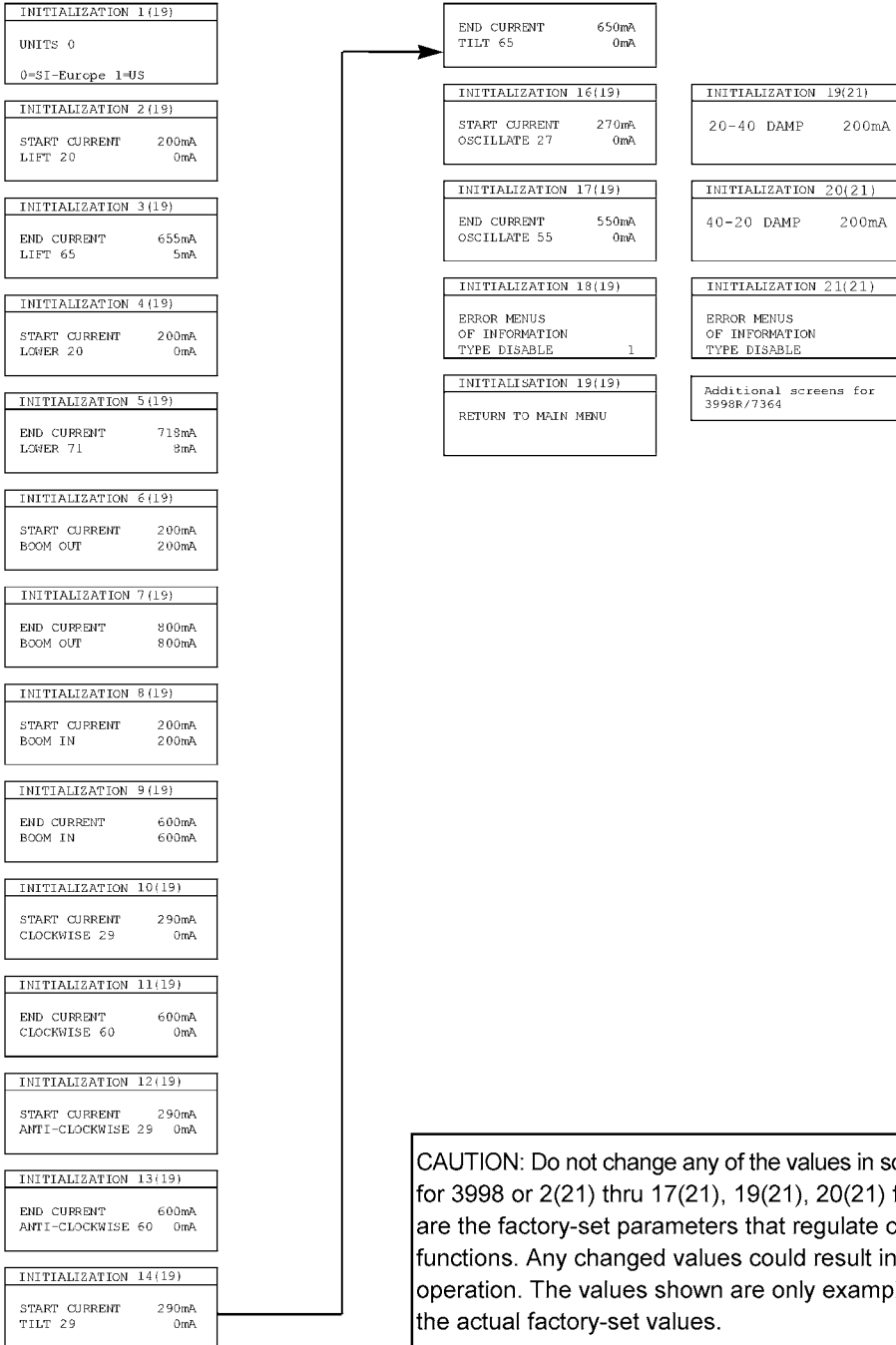
NOTE: The values shown are examples of values but are not the normal values. The values are "real time" values that will change as vehicle status changes. Refer to the Diagnostic Menu explanations (EXHIBIT 1) for further details.

Table 3. Calibration Menu, Access Code 13221.

CALIBR SERVO	CALIBR STEERING	CALIBR GEARBOX	CALIBR RETURN TO MAIN MENU
↓	↓	↓	
CALIBR SERVO 1(10) LOWER MINIMUM 713 BOOM ANGLE 713	CALIBR STEERING 1(10) TURNING SPEED FOR BUTTOW STEERING 60	CALIBR GEARBOX 1(2) AEB CYCLE NR AEB MAIN CODE AEB SUB CODE	
CALIBR SERVO 2(10) LOWER MINIMUM 334 TILT ANGLE 334	CALIBR STEERING 2(10) AXEL 1 ADJUST WHEEL 0 ANGLE 0	CALIBR GEARBOX 2(2) CALIBRATION OF GEARBOX DONE ENTER	
CALIBR SERVO 3(10) LIFT MAXIMUM 354 BOOM ANGLE 354	CALIBR STEERING 3(10) AXEL 1 SET WHEEL 0 ANGLE 0		
CALIBR SERVO 4(10) LIFT MAXIMUM 716 TILT ANGLE 716	CALIBR STEERING 4(10) AXEL 2 ADJUST WHEEL 0 ANGLE 0		
CALIBR SERVO 5(10) BOOM MIN EXTENSION 37	CALIBR STEERING 5(10) AXEL 2 SET WHEEL 0 ANGLE 0		
CALIBR SERVO 6(10) BOOM MAX EXTENSION 441	CALIBR STEERING 6(10) AXEL 3 ADJUST WHEEL 0 ANGLE 0		
CALIBR SERVO 7(10) INIT BY MIN LOAD LE 548 RI 552 548 552	CALIBR STEERING 7(10) AXEL 3 SET WHEEL 0 ANGLE 0		
CALIBR SERVO 8(10) INIT BY MAX LOAD LE 787 RI 790 787 790	CALIBR STEERING 8(10) AXEL 4 ADJUST WHEEL 0 ANGLE 0		
CALIBR SERVO 9(10) ALLOWED LOAD 25000 kg ACTUAL LOAD kg L-LC 2.6 m	CALIBR STEERING 9(10) AXEL 4 SET WHEEL 0 ANGLE 0		
CALIBR SERVO 10(10) CALIBRATION OF EL.SERVO DONE ENTER	CALIBR STEERING 10(10) CALIBRATION OF STEERING DONE ENTER		

NOTE: The values shown are examples of values but are not the normal values. The values are "real time" values that will change as vehicle status changes. Refer to the TM 10-3930-675-24-2, Work Packages 0225 00, 0238 00 and 0259 00 for the calibration procedures.

Table 4. Initialization Menu, Access Code 32131.



ERROR CODE TROUBLESHOOTING - CONTINUED

5. When troubleshooting electronically-identified (error code) malfunctions:
 - a. Locate the symptom or symptoms in WP 0006 00 that best describe the malfunction. Use either the “Alphabetical Error Code Symptom Index” or the “Numerical Error Code Symptom Index”.
 - b. Turn to the work package where the troubleshooting procedures for the malfunction in question are described. Perform any initial setup requirements, then proceed to the table that addresses your particular error code. Headings at the top of each troubleshooting table show how each troubleshooting procedure is organized: MALFUNCTION, TEST OR INSPECTION, and CORRECTIVE ACTION.
 - c. Perform each procedure in the order listed until the malfunction is corrected. DO NOT perform any maintenance task unless the troubleshooting procedure tells you to do so.

EXHIBIT 1 - DIAGNOSTIC MENUS

An explanation of each screen in the diagnostic menus; the normal values and ranges of values. 3998R and 7364 indicated where applicable.

DIAG SERVO

DIAG SERVO	1(13)
SYSTEM POWER	24.00V
POWER RI CAN	24.00V
POWER LE CAN	24.00V
10V REF OUT	10.00V

Supply voltages to ECU 790 connector 1.
Normal voltages; 23 to 27V.

10V reference voltage output from ECU 790 connector 1 to joystick, boom extension sensor, and boom angle sensor.

DIAG SERVO	2(13)
OVERRIDE	0
TWISTLOCK	0

Signal from override switch to ECU 790 connector 1.
Signal from twistlock button to ECU 790 connector 1.
0 = switch not depressed, 1 = switch depressed.

DIAG SERVO	3(13)
SIDE SHIFT RI	0
SIDE SHIFT LE	0
VERTICAL LIFT	0

Signals from the side shift buttons to ECU 790 connector 1.
Signal from index button to ECU 790 connector 1.
0 = switch not depressed, 1 = switch depressed.

DIAG SERVO	4(13)
LOCK TILT	0
LOCK OSCILLATE	0

Signals from the float lock buttons to ECU 790 connector 1.
0 = switch not depressed, 1 = switch depressed.

DIAG SERVO	5(13)
LIFT/LOWER	5.00V
BOOM IN/OUT	5.00V

Signals from the joystick lever to ECU 790 connector 1.
Range = 1 to 9V, Neutral = 5V
Lift = V >5V, Lower = V <5V
In = V <5V, Out = V >5V

DIAG SERVO - CONTINUED

DIAG SERVO	6(13)
SLEW CW/CCW	5.00V
TILT IN/OUT	5.00V

Signals from the slew and tilt buttons to ECU 790 connector 1.
 Range = 1 to 9V, Neutral = 5V
 CW = V>5V, CCW = V<5V
 In = V<5V, Out = V>5V

DIAG SERVO	7(13)
LENGTH SENSOR	1.00V
ANGLE SENSOR	1.50V

Signal from boom extension sensor and boom angle sensor to ECU 790 connector 1.
 Length Sensor Range = .2 to 5V
 Retracted = <1V, Extended = >4V
 Angle Sensor Range = 3 to 9V
 Boom down = 7 to 8V, Boom up = 3 to 4V

DIAG SERVO	8(13)	
PRESS RETURN		
PRESS RI	2.00V	1.50V
PRESS LE	2.00V	1.50V

Signals from lift cylinder pressure sensors to ECU 790 connector 1.
 Pressure Sensor Range = 1 to 10V (0-3625 psi)
 Press RI & LE = Retracted = 3 to 4V
 Press RI & LE = Extended = 5 to 6V
 Return normally <2V, All full down = <2V

DIAG SERVO	9(13)	
OUTPUT	INPUT	
LIFT	0mA	0mA
LOWER	0mA	0mA

Signals to ECU 790 connector 2 from the Servo Pilot Solenoids.
 Output = Target value, Input = Actual value
 Depending on joystick position, the target value appears.
 The actual amperage will rise to closely match the target value.

DIAG SERVO	10(13)	
OUTPUT	INPUT	
BOOM IN	0mA	0mA
BOOM OUT	0mA	0mA

Signals to ECU 790 connector 2 from the Servo Pilot Solenoids.
 Output = Target value, Input = Actual value
 Depending on joystick position, the target value appears.
 The actual amperage will rise to closely match the target value.

DIAG SERVO - CONTINUED

DIAG SERVO		11(13)
	OUTPUT	INPUT
FAN	0mA	0mA
BL. VALVE	0.00V	0mA

Signal from ECU 790 connector 2 to the fan control valve. Controlled by temperature.

Output = Target value, Input = Actual value

Depending on temperature, the target value appears. The actual amperage will rise to closely match the target value.

Fan @ 100% = 200mA, Fan @ 0% = 1200mA

Blocking Valve voltage and amperage when lowering boom. (0 to 24V) ECU 790 con. 2.

DIAG SERVO		12(13)
VALVES	OUTPUT	INPUT
ATTACH.	0.00V	0mA
PUMP OFF	0.00V	0mA

Signals from ECU 790 connector 2 to Attachment and Pump Off valves.

Ignition on with engine off - Aux pump on.

Active tophandler functions; voltage and amperage to Attachment Valve.

Ignition on with engine off; access this screen. Voltage and amperage to Pump Off valve. Turn on engine; no voltage/amp when pumps engage @ 600 RPMs.

DIAG ATTACHMENT

DIAG ATTACH		1(16)
SYSTEM POWER	24.00V	
POWER RI	24.00V	
POWER LE	24.00V	
10V REF OUT	10.00V	

Supply voltages to ECU 791 connector 1.

Normal voltages 23 to 27V.

10V reference voltage output from ECU 791 connector 2 to tilt angle sensor.

DIAG ATTACH		2(16)
TILT ANGLE	5.00V	

Signal from tilt angle sensor to ECU 791 connector 1.

Tilt Angle Sensor Range = 3 to 9V

Tilt in = 7 to 9V, Tilt out = 3 to 4V, level = 4 to 5V

DIAG ATTACHMENT - CONTINUED

DIAG ATTACH			3(16)
ALIGNMENT			
LE FRONT	0	RI FRONT	0
LE REAR	0	RI REAR	0

Signals from alignment proximity switches to ECU 791 connector 1.
 To test; activate manually or engage tophandler in container.
 1 = 24V signal, 0 = no signal

DIAG ATTACH			4(16)
TWISTLOCK			
LE UNL.	0	RI UNL.	0
LE LOCK	0	RI LOCK	0

Signals from twistlock proximity switches to ECU 791 connector 1.
 To test; override twistlocks.
 1 = 24V signal, 0 = no signal

DIAG ATTACH			5(16)
ROTATION +/- 45			1
DAMPING 20/40			0
ATTACHMENT SIG 1			1
ATTACHMENT SIG 2			1

Signals from rotation, damping, and forklift attachment proximity switches to ECU 791 connector 1.
 Rotational/work light lockout; 3998R/7364 only.
 Damping signal occurs during spreading extremes, Attachment signal normally on until the forklift kit is installed. 1 = 24V signal, 0 = no signal.

DIAG ATTACH			6(16)
TW-LOCK	OUTPUT	INPUT	
UNLOCKED	0.00V	0mA	
LOCKED	0.00V	0mA	

Signals from ECU 791 connector 2 to twistlock valve solenoids.
 Voltage (24V) to solenoids and actual amperage through solenoid coils when twistlock function is activated.

DIAG ATTACH			7(16)
SIDE SH.	OUTPUT	INPUT	
LEFT	0mA	0mA	
RIGHT	0mA	0mA	

Signals from ECU 791 connector 2 from the side shift valve solenoids.
 Output = Target value, Input = Actual value
 Activating side shift function; the target value appears. The actual amperage will rise to closely match the target value.

DIAG ATTACHMENT - CONTINUED

DIAG ATTACH		8(16)
	OUTPUT	INPUT
20' - > 40'	0mA	0mA
40' - > 20'	0mA	0mA

Signals to ECU 791 connector 2 from the 20/40 spread valve solenoids.
 Output = Target value, Input = Actual value
 Activating side shift function; the target value appears. The actual amperage will rise to closely match the target value.

DIAG ATTACH		9(16)
LAMPS	OUTPUT	
WORKING LIGHT	0.00V	
WORKING LGT IR	0.00V	

Function not used; 3998 only.
 Voltage from ECU 791 connector 2 to attachment work light relay.
 Activate blackout and IR for IR verification.

DIAG ATTACH		10(16)
IND. LAMP	OUTPUT	
TW UNLOCKED	24.00V	
TW LOCKED	0.00V	

Signal from ECU 791 connector 3 to twistlock indicator lights on boom.
 Voltage to light when all four alignment proximity switches are active (tophandler seated into a container).

DIAG ATTACH		11(16)
IND. LAMP	OUTPUT	
ALIGNMENT	0.00V	

Signals from ECU 791 connector 3 to twistlock indicator lights on boom.
 Voltage to light when all four alignment proximity switches are active (tophandler seated into a container).

DIAG ATTACH		12(16)
	OUTPUT	INPUT
SLEW CW	0mA	0mA
SLEW CCW	0mA	0mA

Signals from ECU 791 connector 3 from the slewing valve solenoids.
 Output = Target value, Input = Actual value
 Activating slewing function; the target value appears. The actual amperage will rise to closely match the target value.

DIAG ATTACHMENT - CONTINUED

DIAG ATTACH		13(16)
	OUTPUT	INPUT
TILT IN	0mA	0mA
TILT OUT	0mA	0mA

Signals to ECU 791 connector 3 from the tilt valve solenoids.
 Output = Target value, Input = Actual value
 Activating tilt function; the target value appears.
 The actual amperage will rise to closely match the target value.

DIAG ATTACH		14(16)
	OUTPUT	INPUT
OSC. RI	0mA	0mA
OSC. LE	0mA	0mA

Signals to ECU 791 connector 3 from the oscillation valve solenoids.
 Output = Target value, Input = Actual value.
 Activating oscillate function; the target value appears.
 The actual amperage will rise to closely match the target value.

DIAG ATTACH		15(16)
ACTIVE	OUTPUT	INPUT
OSC.	24.00V	900mA
TILT	24.00V	900mA

Signals from ECU 791 connector 3 to float lock valve solenoids.
 Voltage (24V) to solenoids and actual amperage through solenoid coils when float lock function is activated.

DIAG STEERING

DIAG STEERING		1(16)
DIG IN		
STEERING	2WD	0
STEERING	4WD	0
STEERING	CRAB	0

Signals from steering mode buttons to ECU 792.
 1 = 24V signal, 0 = no signal.

DIAG STEERING - CONTINUED

DIAG STEERING	2(16)
ERROR CODE	255
FROM 792, STEERING	

Displays active error codes for the steering system; ECU 792.
 255 is the NORMAL indication that **NO** error codes are present.
 Error codes will be displayed in an off-set of 300.
 Example: 14 = 314 or 40 = 340.

DIAG STEERING	3(16)
REQ. PROGRAM	0
0 : 2WD	1 : 4 WD
2 : CRAB	3 : EMERGENC

Steering program changes and status.
 The number next to Req. Program will change to reflect the actual steering mode engaged.

DIAG STEERING	4(16)
EME. OPERATION MODE	0
STEER. PROG CHANGE	0
NEUTRAL GEAR STAT.	0

Emergency steering mode status.
 Steering program change will indicate an active change from one steering mode to another.
 Neutral gear status is a signal sent from ECU 792 to ECU 793 (transmission) to enable the transmission.
 Any steering fault will terminate the signal and the transmission will disengage.
 Normal = 1, Steering fault = 0

DIAG STEERING	5(16)
PRESSURE SW. STAT	0
SUPPLY PRESSURE	0

Signal from the steering pressure switch to ECU 792.
 Both values in the screen change at the same time.
 Normal = 1, Fault = 0
 Axle 1 = Right Front, Axle 2 = Right Rear
 Axle 3 = Left Rear, Axle 4 = Left Front

DIAG STEERING	6(16)
ERROR STATUS	
AXLE 1 : 0	AXLE 2 : 0
AXLE 3 : 0	AXLE 4 : 0

Any electrical fault of wheel sensor, steering solenoid, or ECU 792 power supply.
 0 = pressure, <1,450 psi = (100 bar)
 1 = pressure, <1,450 psi = (100 bar)

DIAG STEERING - CONTINUED

DIAG STEERING	7(16)
STEERING WHEEL	
SIG LE	0
RI	0

Signals from steering force simulator to ECU 792.
 The values will change displaying positive and negative numbers when steering wheel is turned.
 Both 0 when the steering wheel is still.

DIAG STEERING	8(16)
RI FRONT WHEEL ANGLE	
SIGNAL 1	0
SIGNAL 2	0

Signals from right front wheel sensor to ECU 792 =
 Actual wheel angle
 Full left = -17 typically
 Full right = +22 typically
 Wheels straight = 0
 Range = -23 to +23 degrees

DIAG STEERING	9(16)
RI REAR WHEEL ANGLE	
SIGNAL 1	0
SIGNAL 2	0

Signals from right rear wheel sensor to ECU 792 =
 Actual wheel angle
 Full left = +17 typically
 Full right = -22 typically
 Wheels straight = 0
 Range = -23 to +23 degrees

DIAG STEERING	10(16)
LE REAR WHEEL ANGLE	
SIGNAL 1	0
SIGNAL 2	0

Signals from left rear wheel sensor to ECU 792 =
 Actual wheel angle
 Full left = +22 typically
 Full right = -17 typically
 Wheels straight = 0
 Range = -23 to +23 degrees

DIAG STEERING	11(16)
LE FRONT WHEEL ANGLE	
SIGNAL 1	0
SIGNAL 2	0

Signals from left front wheel sensor to ECU 792 =
 Actual wheel angle
 Full left = -22 typically
 Full right = +17 typically
 Wheels straight = 0
 Range = -23 to +23 degrees

DIAG STEERING - CONTINUED

DIAG STEERING	12(16)
RI FRONT WHEEL	
SOLENOID CW	0
SOLENOID CCW	0

Signals from ECU 792 to right front CW and CCW steering valve solenoids.
 The value will rise to the direction the wheel is turned while the other remains 0.
 Wheel still; the numbers bounce between values.
 Range = 0 to <50 typically.

DIAG STEERING	13(16)
RI REAR WHEEL	
SOLENOID CW	0
SOLENOID CCW	0

Signals from ECU 792 to right rear CW and CCW steering valve solenoids.
 The value will rise to the direction the wheel is turned while the other remains 0.
 Wheel still; the numbers bounce between values.
 Range = 0 to <50 typically.

DIAG STEERING	14(16)
LE REAR WHEEL	
SOLENOID CW	0
SOLENOID CCW	0

Signals from ECU 792 to left rear CW and CCW steering valve solenoids.
 The value will rise to the direction the wheel is turned while the other remains 0.
 Wheel still; the numbers bounce between values.
 Range = 0 to <50 typically.

DIAG STEERING	15(16)
LE FRONT WHEEL	
SOLENOID CW	0
SOLENOID CCW	0

Signals from ECU 792 to left front CW and CCW steering valve solenoids.
 The value will rise to the direction the wheel is turned while the other remains 0.
 Wheel still; the numbers bounce between values.
 Range = 0 to <50 typically.

DIAG GEARBOX

DIAG GEARBOX	1(12)
SPEED:	0 MPH 0 kph
ENGINE	0 rpm
OUTPUT SHAFT	0 rpm

Actual values of RTCH speed, engine RPM and output shaft RPM.

DIAG GEARBOX	2(12)
ERROR CODE	0X 0
FROM 793, GEARBOX	

Active error codes as per ZF transmission manufacturer.

The (ZF) number letter combinations displayed will have a corresponding Kalmar error code. Normal = 0, Fault = any number/letter combo.

DIAG GEARBOX	3(12)
GEAR PROGRAM	
0 : 2WD	1 : 4 WD
2 : CRAB	3 : MANUAL

Actual engaged steering/transmission program.

DIAG GEARBOX	4(12)
SHIFT LEVER POSITION	
FORWARD	0
NEUTRAL	1
REVERSE	0

Signals from the transmission selector lever to ECU 793.

DIAG GEARBOX	5(12)
SH. POSITION RANGE	3
DRIVE LINE ENGAGED	0

Signals from the transmission selector lever to ECU 793. (Gear position)

Indicator of actual engagement of a gear and direction. 1 = Engaged, 0 = Disengaged

DIAG GEARBOX - CONTINUED

DIAG GEARBOX	6(12)
OIL TEMP	0GrC
OIL TEMP SUMP	0GrC

Signals from two temperature sensors in the transmission to ECU 793.
Normal = 80 to 90°C (175 to 195°F)

DIAG GEARBOX	7(12)
ACTUAL DIRECTION:	
FORWARD	0
NEUTRAL	1
REVERSE (REVE. LAMP)	0

Signals from ECU 793 to transmission proportional valve solenoids.
1 = Engaged, 0 = Disengaged

DIAG GEARBOX	8(12)
ACTUAL GEAR	0
LIMIT TO 1 ST GEAR	0
0 = 2WD 1 = 4WD	0

Actual gear is the signals from the ECU 793 to the transmission proportional valve solenoids.
Signal from under cab proximity switch to ECU 793.
1 = Cab in transport position
0 = Cab in operational position
Signal from driveshaft connection switch in the transmission to ECU 793.

DIAG GEARBOX	9(12)
GEARBOX MODE:	
NORMAL	1
SUBST. CLUTCH CONT.	0
LIMP HOME	0

Normal: No faults detected.
Substitute Clutch Control: Minor fault detected. Transmission controlled by time controlled and fix ramp shifts.
Limp home: Fault that limits control of shifting. Usually limited to one gear and/or direction. Shifts to neutral if out of controlled limits during this mode.

DIAG GEARBOX - CONTINUED

DIAG GEARBOX	10(12)
TRANS. SHUTDOWN	0
TCU SHUTDOWN	0
SHIFT IN PROGRESS	0

Trans. Shutdown: Major faults detected. All signals to proportional valve solenoids shut off. Shifts to neutral.

TCU Shutdown: Major fault detected that disables control of system. All signals from ECU 793 stopped. Transmission shifts and stays in neutral.

DIAG GEARBOX	11(12)
P-BRAKE	0
INCHING	0
STEERING SYST. OK	0

Signal from parking brake pressure and transmission disconnect switches to ECU 793.

0 = Park brake ON, 1 = Park brake OFF

0 = Trans disc. OFF, 1 = Trans disc. ON

Signal from ECU 792 (steering) to ECU 793.

See Diag. Steering 4(16) Neutral Gear Stat.

1 = All OK, 0 = Steering fault; trans in neutral.

DIAG ENGINE

DIAG ENGINE	1(5)
DEMAND TORQUE	0
ACTUAL TORQUE	0
ENGINE SPEED	0 rpm

Information values of engine torque and RPMs.

DIAG ENGINE	2(5)
ENGINE SPEED	0 rpm
(+) INCREASE	
(-) DECREASE	

Engine RPMs

(+) Increase, (-) Decrease not used and does not appear; 3998R/7364

DIAG ENGINE	3(5)
ENGINE OIL TEMP	0GrC
COOLANT TEMP	0GrC
OIL PRESSURE	0Bar

Engine temperature and pressure values.

Normal values:

Oil temp - 91 to 116°C (195 to 240°F)

Coolant temp = 79 to 99°C (175 to 210°F)

Oil pressure = 1.03 to 2.41 Bar (15 to 35 psi)

DIAG ENGINE - CONTINUED

DIAG ENGINE	4(5)
OIL PRESSURE	0Bar
BOOST PRESS.	0Bar

Engine oil pressure and turbo boost pressure.
 Normal values:
 Oil pressure normally 1.03 to 2.41 Bar
 Boost pressure normally <2Bar

DIAG EXTRA FUNCTION

EXTRA FUNCT.	1(13)
SET ENGINE SPEED TO 1000 rpm (+/-)	0

Engine speed function for high idle or normal idle.
 + = 1,000 RPM high idle = 1
 - = 700 RPM normal idle = 0
 Engine speed returns to normal idle when leaving this screen.

EXTRA FUNCT.	2(13)
CUT OFF THE HYDRAULIC PUMP (+/-)	0

Signal from ECU 790 connector 2 to pump off valve (611).
 + = voltage to valve; pumps off = 1
 - = no voltage to valve; pumps on = 0
 Controls steering and tophandler pumps.

EXTRA FUNCT.	3(13)
EL. HYD. PUMP INPUT	0
EL. HYD. PUMP OUTPUT	0

Input signal from Aux pump switch to ECU 792.
 Output voltage from ECU 792 to Aux pump relay.
 0 = No voltage, 1 = Voltage (on)
 Active Aux pump switch to test.

DIAG EXTRA FUNCTION - CONTINUED

EXTRA FUNCTION	4(13)
WATER LEVEL (0 = CUT OFF FAN)	0

Signal from fording switch to ECU 792.
Voltage to ECU 792 keeps fan operational.
Voltage is removed while fording to turn off fan.
0 = Fan off, 1 = Fan on

EXTRA FUNCTION	5(13)
BLACKOUT	0
WORK LIGHT ATTACH	0

Signal from blackout light switch to ECU 790 connector 1.
0 = Off, 1 = On
Signal from tophandler work light switch to ECU 792.
0 = Off, 1 = On

EXTRA FUNCTION	6(13)
HYD FILTER BOOM	0
HYD FILTER STEERING	0
HYD FILTER ATTACH	0
HYD FILTER RET. OIL	0

Signals from hydraulic filter indicators to ECU 792.
Filter exceeds pressure drop.
Normal = 0
Change filter = 1
Not used on 3998R/7364

EXTRA FUNCTION	7(13)
BRAKE CIRCUIT 1	0
BRAKE CIRCUIT 2	0

Signal from brake pressure switches to ECU 790 connector 1.
0 = No pressure, 1 = Pressure
Pressure switches are connected to the accumulator side of the brake system.

DIAG EXTRA FUNCTION - CONTINUED

EXTRA FUNCTION	8(13)
ETHER START OK	0
CABIN OP. POS	0
CABIN SIDE POS.	

Ether start function input to ECU 792.
 Signal from cab operational position proximity switch to ECU 793.
 Signal from cab in transport position proximity switch to ECU 792.
 0 = No voltage, 1 = Voltage 24V

EXTRA FUNCTION	9(13)
Rx 792, STEERING	0
Rx 793, GEARBOX	0
Rx 794, ENGINE	0

ECU communication in the CAN-BUS system.
 1 = OK, 0 = Fault

EXTRA FUNCTION	10(13)
ACT. SPEED CONTROL MAX rpm	0

Function not used on 3998, 3998R, or 7364.



EXTRA FUNCTION	10(13)
SET OUTPUT SIG COENTRAL LUB (+/-)	0

Voltage to Autolube printed circuit board.
 Used to activate a manual lube cycle.
 1 = voltage (24V), 0 = No voltage
3998R/7364 only.
 Autolube currently not used on **3998R.**

DIAG EXTRA FUNCTION - CONTINUED

EXTRA FUNCTION	11(13)
INTAKE TEMP 23	FAN
COOLANT TEMP 43	SPD
GEAR BOX TEMP 52	33
HYD OIL TEMP 55	

Normal Temps:

Intake = <65°C (150°F)

Coolant = 79 to 99°C (175 to 210°F)

Trans = 80 to 90°C (175 to 195°F)

Hyd = <71°C (160°F)

Fan speed can be controlled by + or - or R to shut fan off.

The fan speed returns to the current speed when leaving this screen.

EXTRA FUNCTION	12(13)
WHEEL END FRONT	50
WHEEL END REAR	51
HYD TANK	40
BRAKE COOLING	1

Brake chamber temperature sensors.

Left front and rear hubs.

Normal = 95°C (203°F)

Open = -30, Shorted = 155

Hyd temp = <71°C (160°F)

Signals to brake cooling bypass solenoids from ECU.

792.0 = Bypass, 1 = Brk cooling




EXPLANATION OF ERROR CODE DISPLAY

NOTE

There are three kinds of information in the Electronic Control System (ECS) display.






- Icons in the *lower left corner* of the display describe what the driver should do. Table 5 defines each of the three driver actions.

Table 5. Driver Action Icons.

ICON	DESCRIPTION
	<p>STOP VEHICLE IMMEDIATELY in a safe way. Can be a safety issue. Machine performance may be restricted. Read operator's manual for instructions. Contact maintenance personnel.</p>
	<p>WARNING - DEGRADED OPERATION, stop vehicle in a safe way. Read operator's manual for instructions. Contact maintenance personnel. Confirm that error message is acknowledged by pressing RESET button. Error will appear every three minutes as long as error is active. It can be reset every time it shows.</p>
	<p>INFORMATION/MAINTENANCE action is needed. Error code shows once when vehicle starts up. Acknowledge error message by pressing RESET. These error codes may be deactivated for driver, so that they only show when maintenance personnel activate them. RESET/USMC only. The information/maintenance icon will appear in the ECS display operational screen (weight/load center) to alert the maintenance personnel of potential service.</p>

- Icons in the *center* of the display identify the type of fault. Table 6 describes the five fault types used in the display.





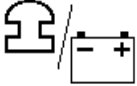





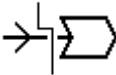

Table 6. Type of Fault Icons.

ICON	DESCRIPTION	ICON	DESCRIPTION
	Sensor		Lever
	Valve		Temperature
	Pressure		

EXPLANATION OF ERROR CODE DISPLAY - CONTINUED

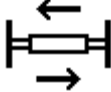

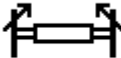

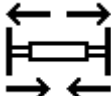


3. Icons in the *right* of the display identify what function or vehicle system the fault is related to. Table 7 lists the various functions or vehicle systems used in the display.

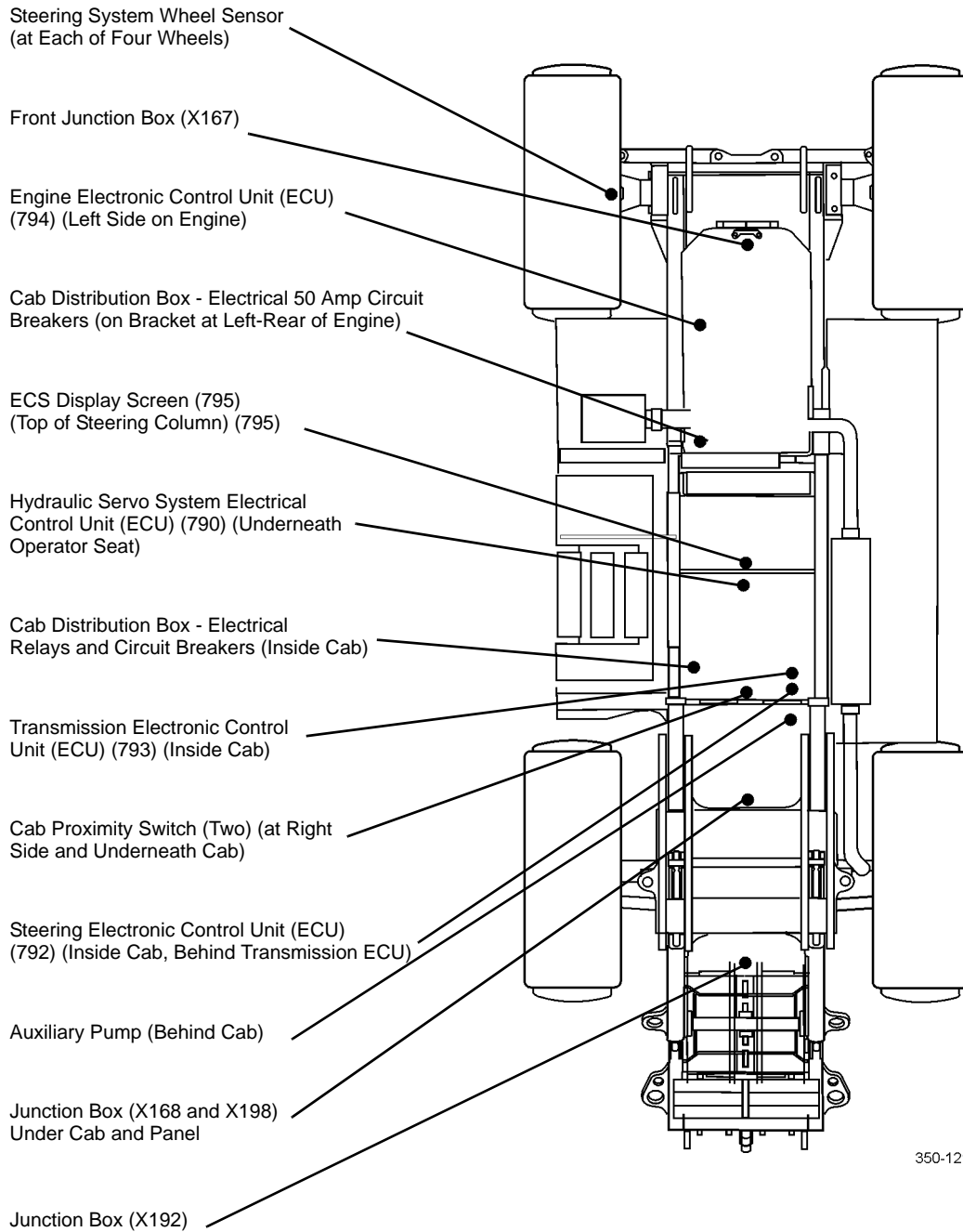
Table 7. Function Icons.

ICON	DESCRIPTION	ICON	DESCRIPTION
	Battery		Twistlock
	Forklift kit		Up/Down
	Emergency stop or battery		In/Out
	Rotation RESET/USMC only ECS display; lockout indication		Transmission RESET/USMC only ECS display; lockout indication
	Hydraulic filter		Fan
	Communication		Engine

EXPLANATION OF ERROR CODE DISPLAY - CONTINUED

Table 7. Function Icons - Continued.

ICON	DESCRIPTION	ICON	DESCRIPTION
	Sideshifting		No overload protection
	Oscillation (leveling)		Brake
	Spreading		Tilt RESET/USMC only ECS display; lockout indication
	Steering		



350-1216

Figure 1. Electrical Component Location - Chassis.

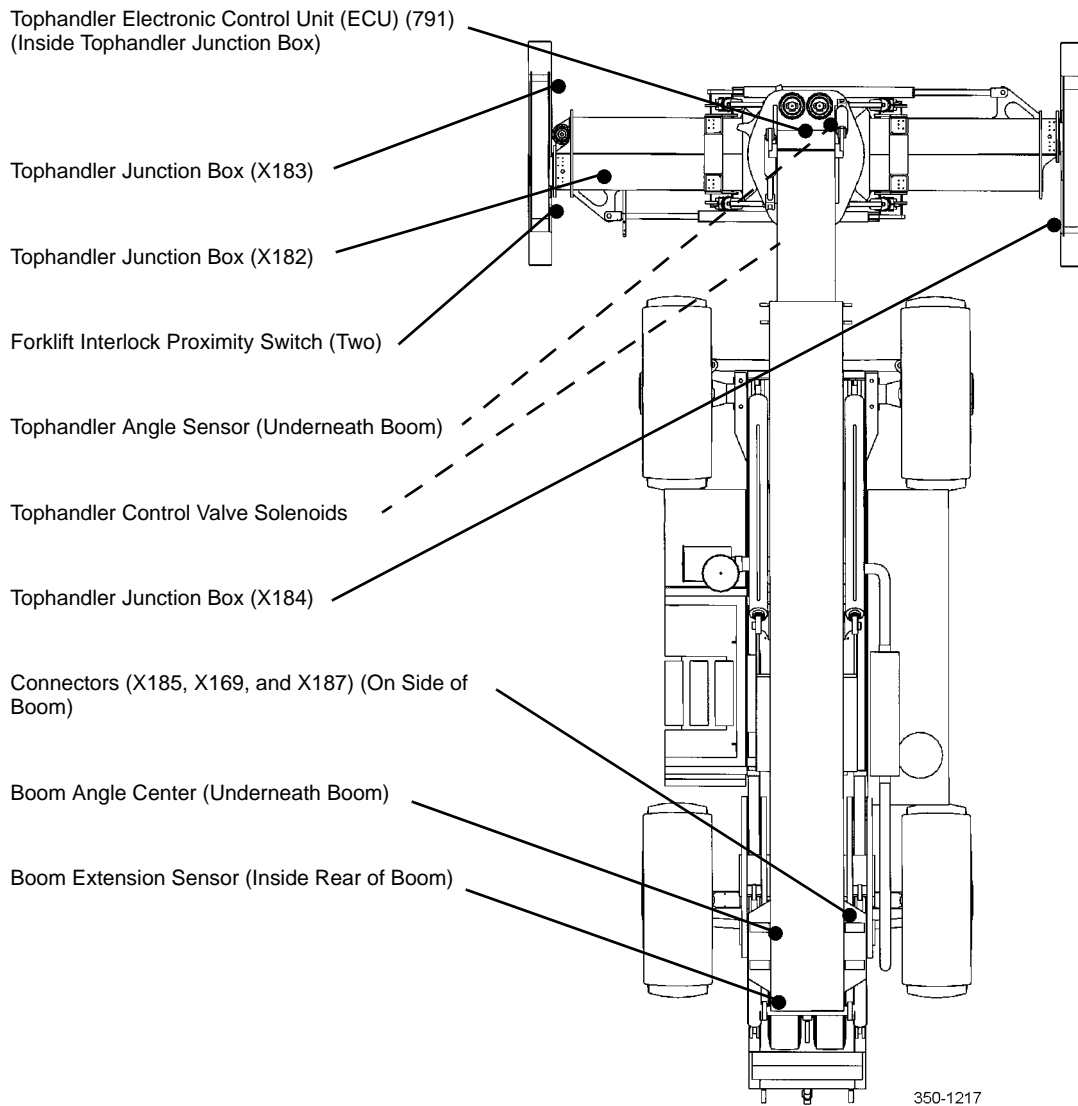
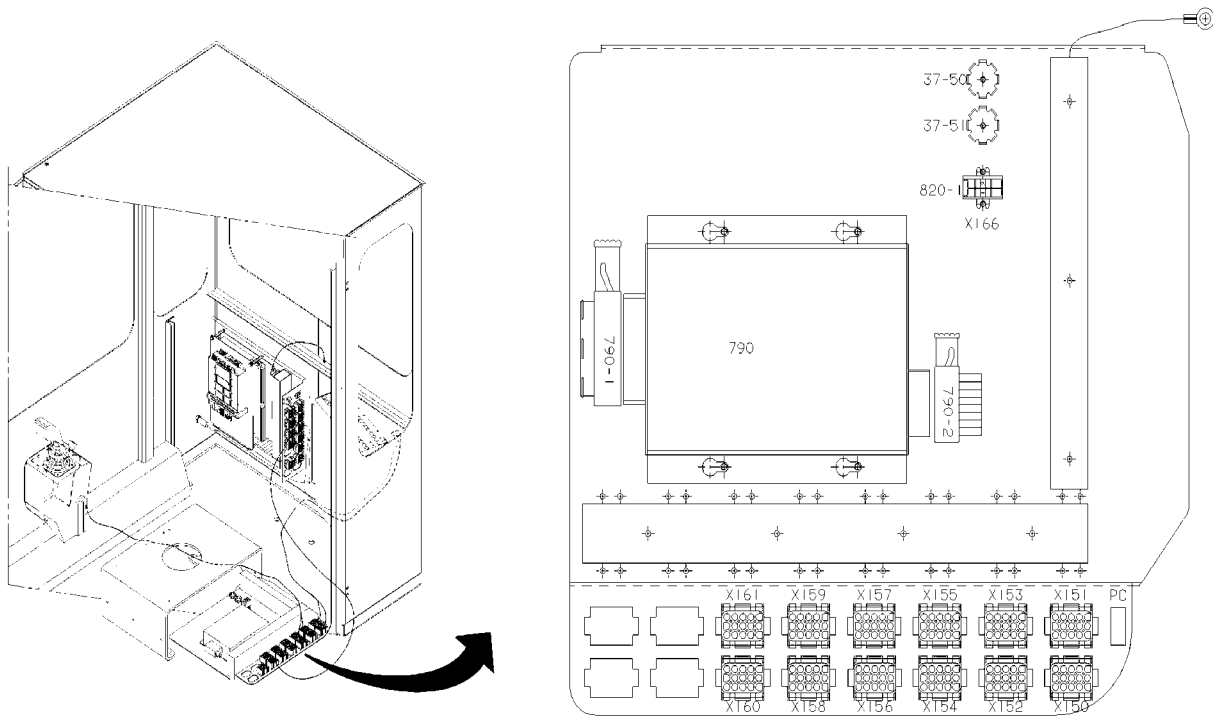


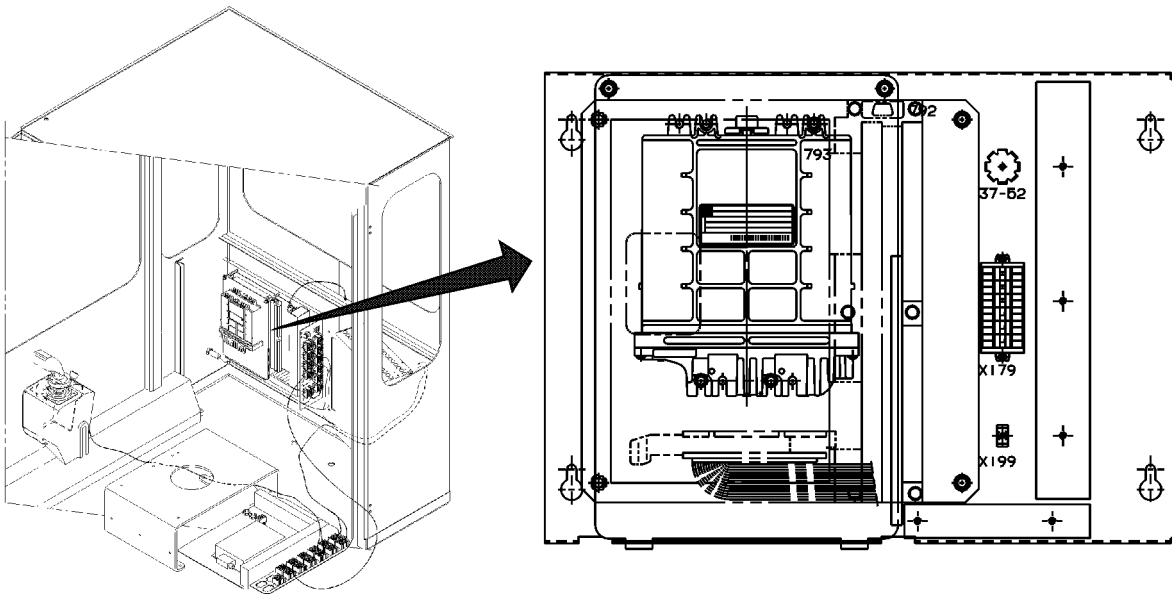
Figure 2. Electrical Component Location - Boom and Tophandler.



CONNECTORS:

X150	X156	X166
X151	X157	790-1
X152	X158	790-2
X153	X159	37-50
X154	X160	37-51
X155	X161	

Figure 3. Electrical Connectors - Under Operator's Seat.



350-1338

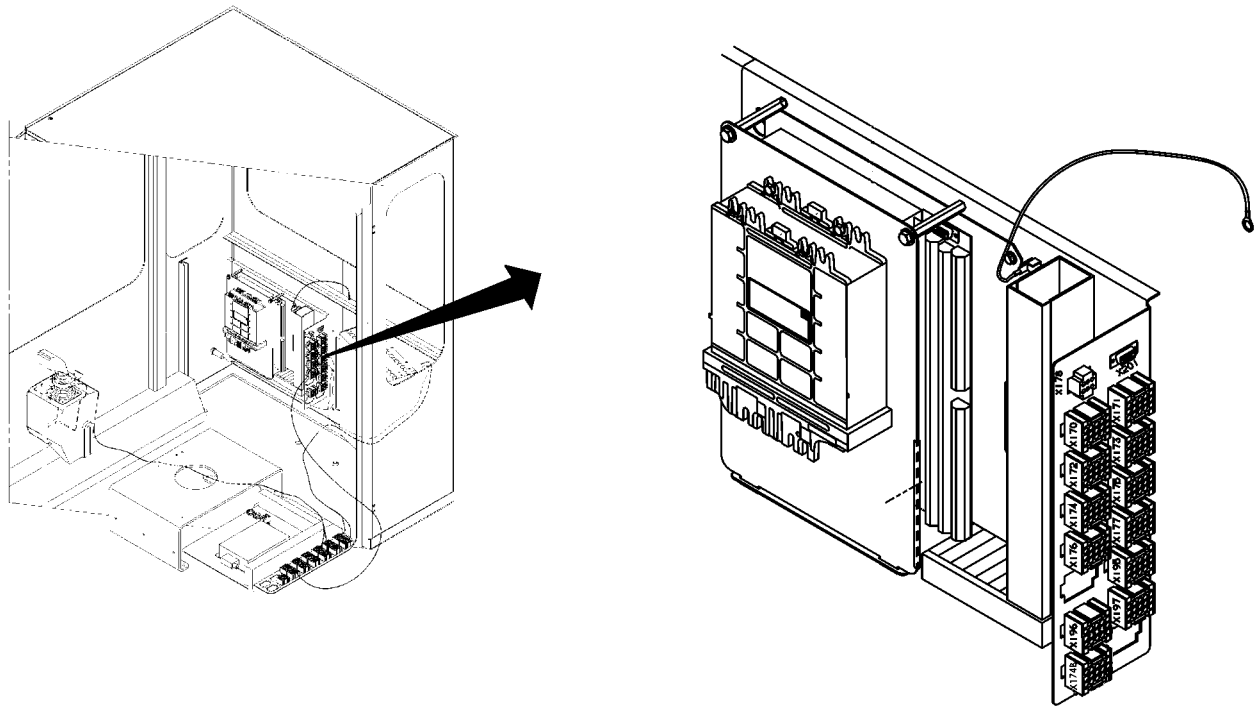
CONNECTORS:

X179

X199

37-52

Figure 4. Electrical Connectors - Behind Right-Rear Panel, Cab Rear Wall.

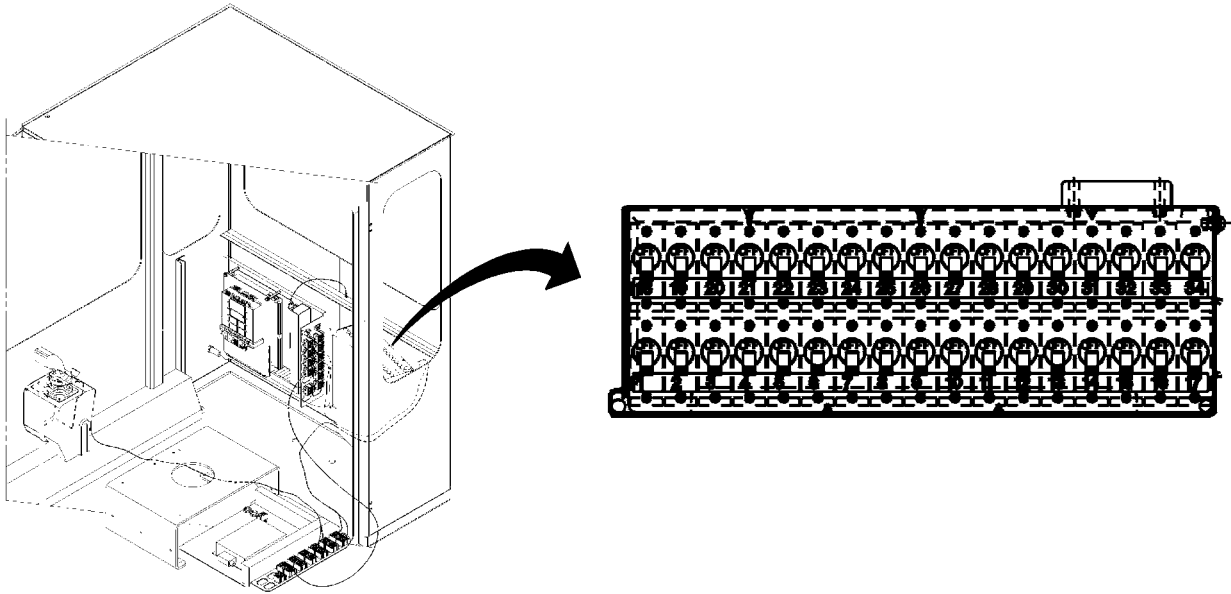


350-1339

CONNECTORS:

X170	X175	X196
X171	X176	X197
X172	X177	X201
X173	X178	X174B (RESET and USMC ONLY)
X174	X195	

Figure 5. Electrical Connectors - Behind Center Panel, Cab Rear Wall.

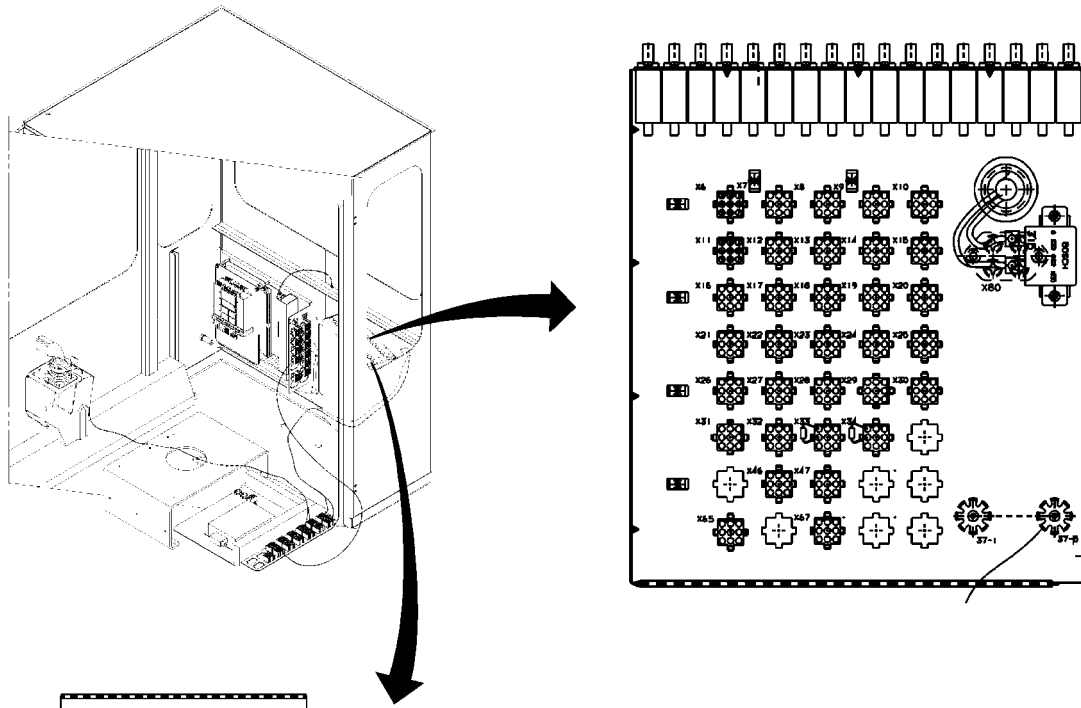


350-1340

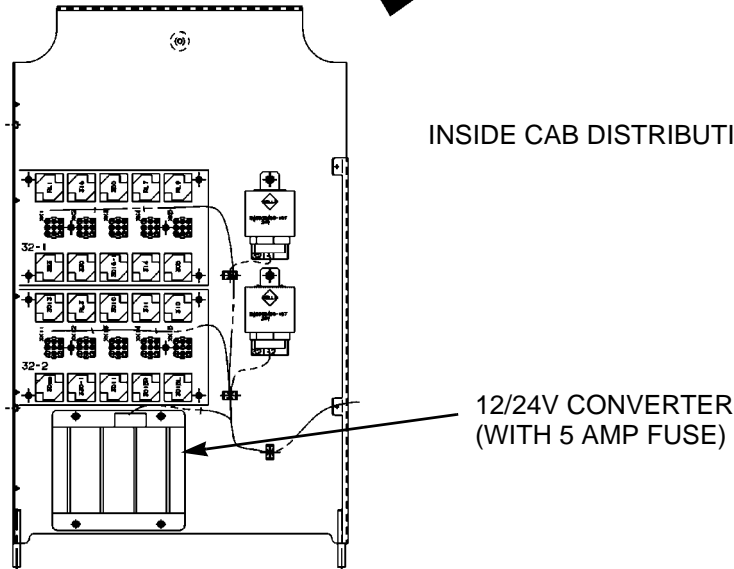
CIRCUIT BREAKERS (CB):

F1 (25A)	ARMY/RESET	F11 (20A)	USMC only	F18 to F26	(5A)
F1 (20A)	USMC ONLY	F12	(15A)	F27 to F29	(10A)
F2 to F6	(10A)	F13 and F14	(5A)	F30	(15A)
F7 and F8	(5A)	F15	(10A)	F31 and F32	(5A)
F9 and F10	(10A)	F16	(15A)	F33 (5A)	RESET/USMC
F11 (25A)	ARMY/RESET	F17	(10A)	F34 (10A)	USMC ONLY

Figure 6. Circuit Breakers - Behind Left-Rear Panel, Cab Rear Wall.



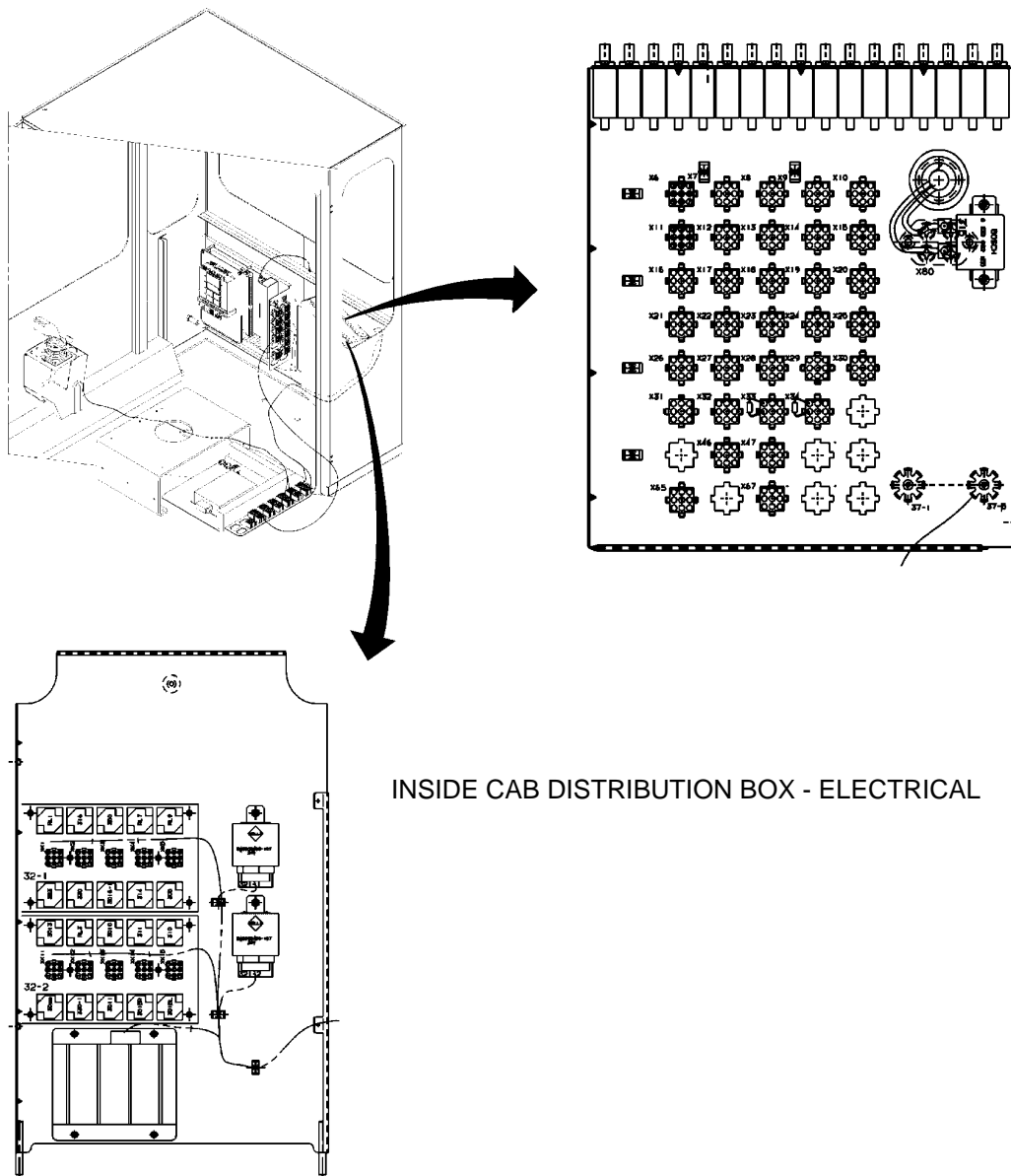
INSIDE CAB DISTRIBUTION BOX - ELECTRICAL



CONNECTORS:

XK1	XK11	X6 to X10	X31 to X32	X69
XK2	XK12	X11 to X15	X33 to X34 (ARMY and RESET)	
XK3	XK13	X16 to X20	X46	X80
XK4	XK14	X21 to X25	X47	37-1
XK5	XK15	X26 to X30	X67	37-5

Figure 7. Electrical Connectors and Voltage Converter - Behind Left-Rear Panel, Cab Rear Wall.

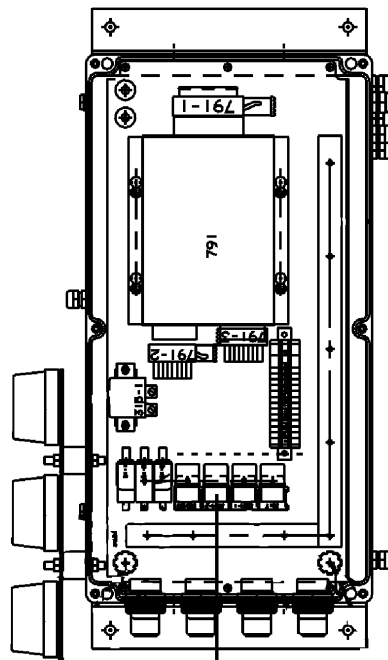
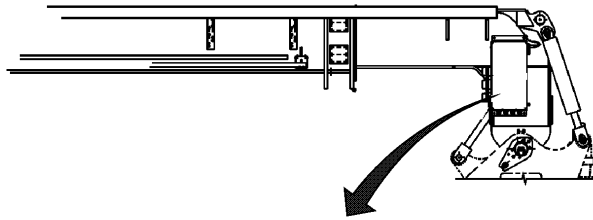


INSIDE CAB DISTRIBUTION BOX - ELECTRICAL

RELAYS:

323	Flasher Relay	3013	Boom Work Light BO	3015L	Turn Signal, Brake Light, Left
316	Wiper	3016	Horn	310	Left Direction
330	Starter Interlock	330-1	Starter Interlock	321-1	Wiper, Intermittent
350	Auxiliary Pump	3010	Brake Light	321-2	Wiper, Intermittent, Rear
3016-1	Seat Buzzer	3011	Reversing Light STD/BO	315	Ignition
314	Parking Brake	311	Right Direction	3018	Autolube (USMC ONLY)
305	Reversing Light/Alarm	3015R	Turn Signal, Brake Light, Right		

Figure 8. Relays - Behind Left-Rear Panel, Cab Rear Wall.



350-1342

CONNECTORS:

X180	X189	X186-2	791-3
X181	X194	791-1	
X188	X186-1	791-2	

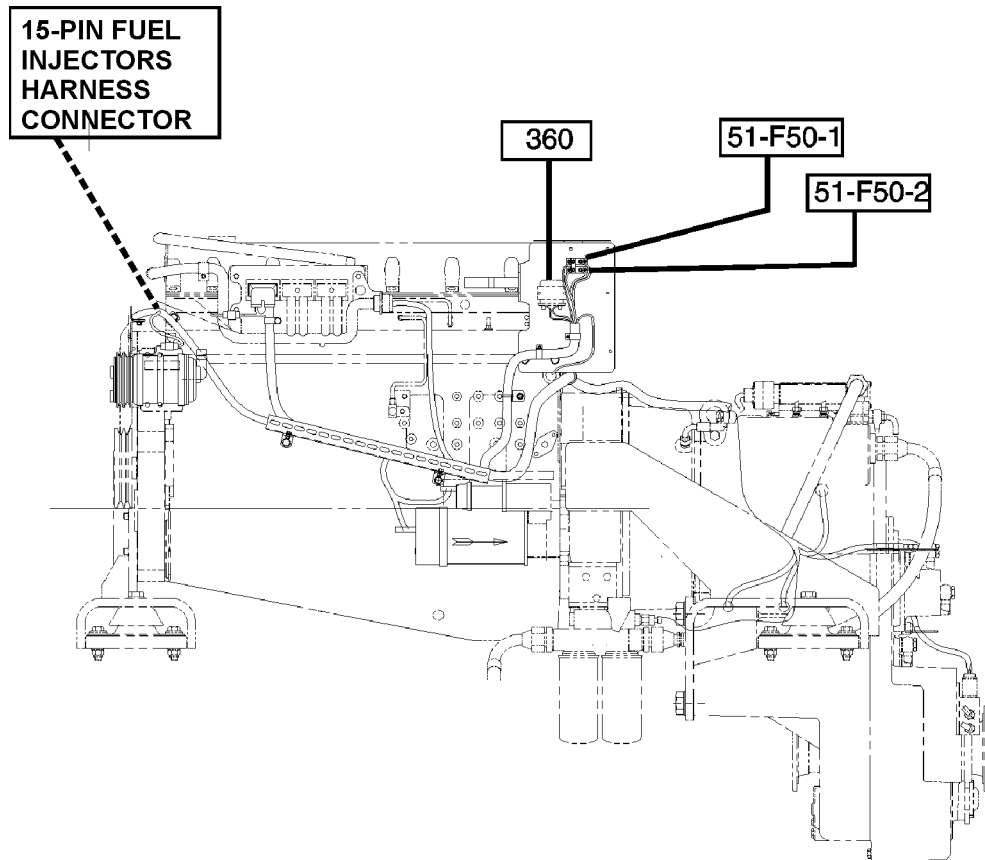
CIRCUIT BREAKERS (CB):

- F41 (1) (10A)
- F42 (2) (10A)
- F43 (3) (10A)

RELAYS:

- 315-1 Starting Key
- 3009-1 Emergency Stop
- 3009-2 Emergency Stop
- 3009-3 Emergency Stop
- 3017 Work Lights

Figure 9. Electrical Connectors, Circuit Breakers (CB), and Relays - Inside Tophandler Junction Box.



350-1343

CIRCUIT BREAKERS (CB):

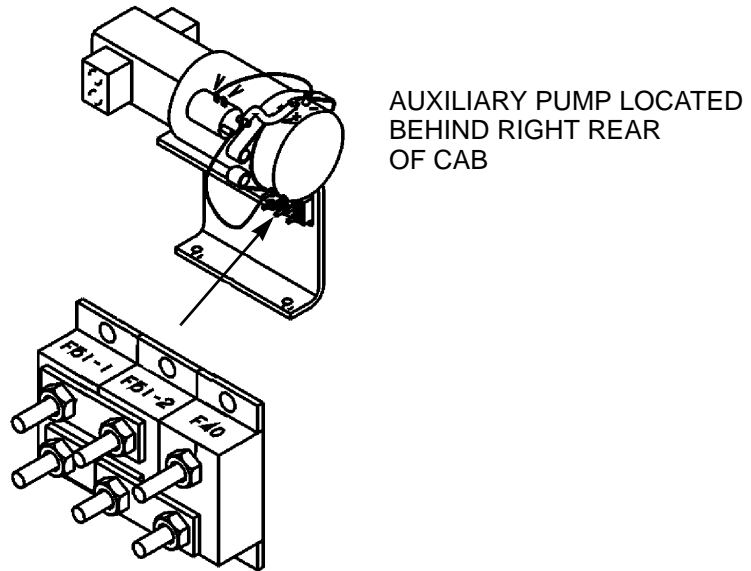
F50-1 (50A)

F50-2 (50A)

RELAY:

360 Starter Solenoid

Figure 10. Circuit Breakers (CB) and Relay - Left Side of Engine.



350-1344

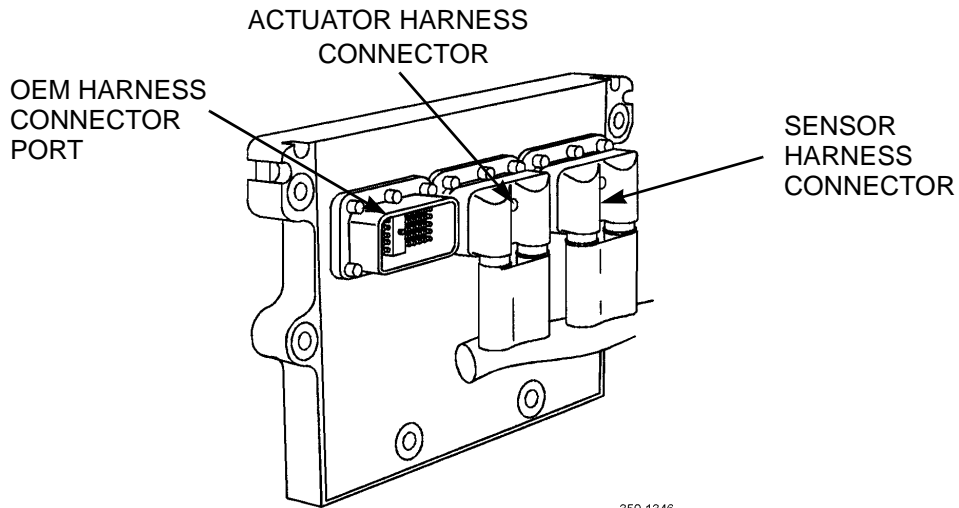
CIRCUIT BREAKERS (CB):

F51-1	(50A)	Aux Pump
F51-2	(50A)	Aux Pump
F40	(50A)	Tophandler

RELAY:

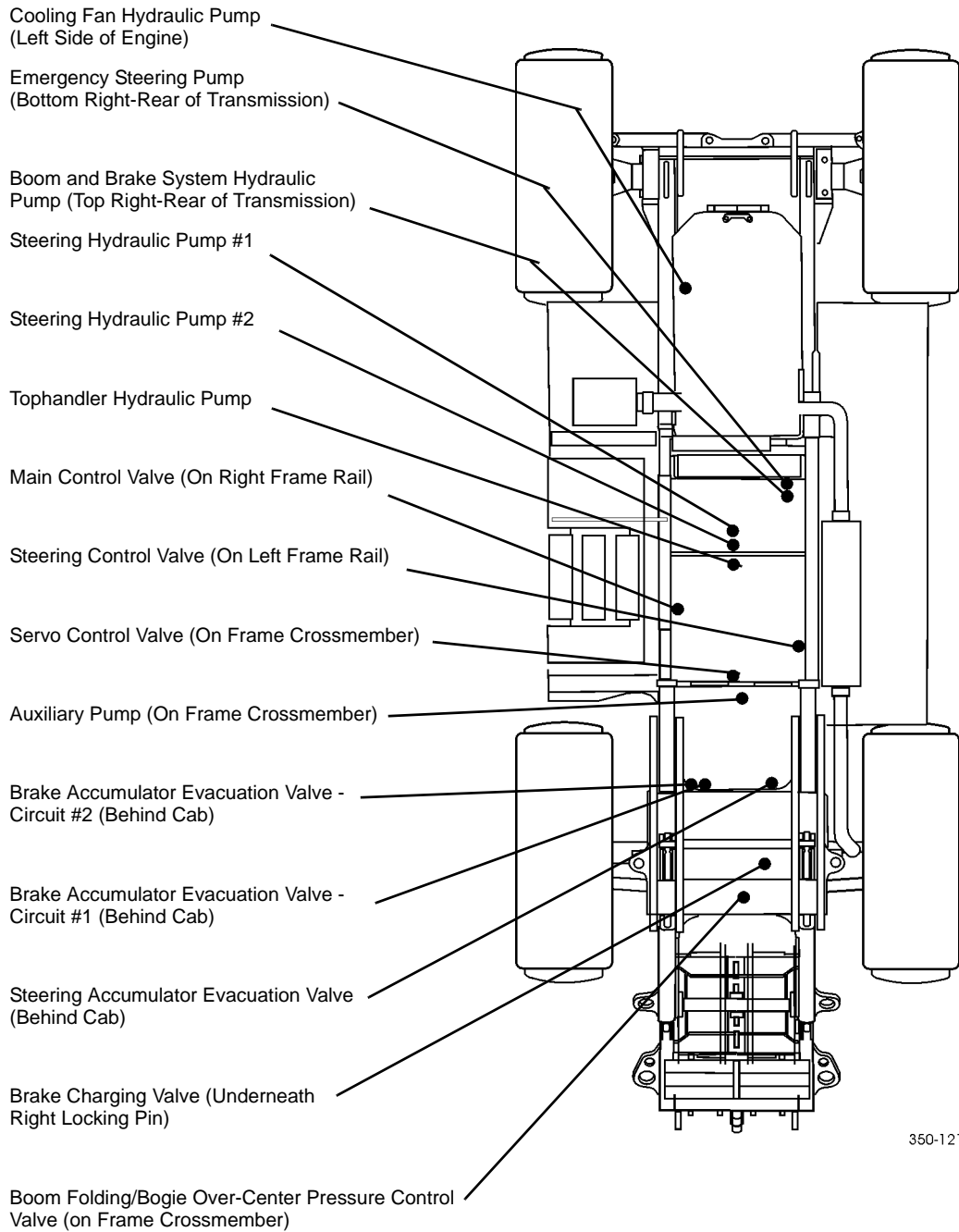
350-1	Aux Ele Hyd Pump
-------	------------------

Figure 11. Electrical Connector, Circuit Breakers (CB), and Relay - Auxiliary Pump.



350-1346

Figure 12. Engine ECU Connectors.



350-1218

Figure 13. Hydraulic Component Location.

END OF WORK PACKAGE

Table 1. Error Codes.


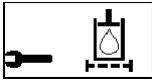


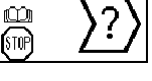
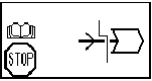
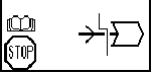
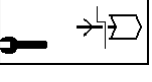
ERROR CODE	DISPLAY LAYOUT	DRIVER ACTION	ERROR CODE CATEGORY/ EXPLANATION	VEHICLE LIMITATIONS
1		Finish Mission Notify maintenance.	Information/Maintenance Lifting/lowering boom Hydraulic filter clogged.	None.
2		Finish Mission Notify maintenance.	Information/Maintenance Steering Hydraulic filter clogged.	None.
3		Finish Mission Notify maintenance.	Information/Maintenance Tophandler attachment Hydraulic filter clogged.	None.
4		Finish Mission Notify maintenance.	Information/Maintenance Return filter Hydraulic filter clogged.	None.
103		Stop Vehicle Check for an ECU with mismatching software. Notify maintenance.	Information/Maintenance Appears during replacement of ECU. Software not compatible with other software in system.	Undesired functions and not relevant error codes may appear.
105		Stop Vehicle Put load down safely. Abort mission. Notify maintenance.	Stop Vehicle Immediately ECU 790 not responding Circuit breaker tripped. Cable defective. ECU 790 defective.	Operating system not respon- ding. Boom and tophandler may not work.
106		Stop Vehicle Put load down safely. Abort mission. Notify maintenance.	Stop Vehicle Immediately ECU 791 not responding Circuit breaker tripped. Cable defective. ECU 791 defective.	Operating system not respon- ding. Boom and tophandler may not work.
107		Press RESET Finish mission. Notify maintenance.	Information/Maintenance Communication, cable segment 1 between ECU 795 and 791 Cable between ECU 795 - 791 interrupted or short circuited.	No redundancy in ECS system of boom, display, and tophandler function.

Table 1. Error Codes - Continued.

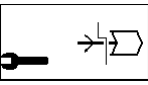
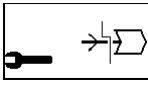
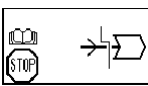
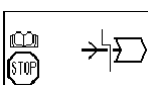
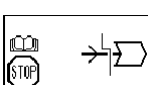
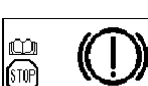
ERROR CODE	DISPLAY LAYOUT	DRIVER ACTION	ERROR CODE CATEGORY/ EXPLANATION	VEHICLE LIMITATIONS
108		Press RESET Finish mission. Notify maintenance.	Information/Maintenance Communication, cable segment 2 between ECU 791 and 790 Cable between ECU 791 - 790 interrupted or short circuited.	No redundancy in ECS system of boom, display, and tophandler function.
109		Press RESET Finish mission. Notify maintenance.	Information/Maintenance Communication, cable segment 3 between ECU 790 and 795 Cable between ECU 790 - 795 interrupted or short circuited.	No redundancy in ECS system of boom, display, and tophandler function.
110		Stop Vehicle Abort mission. Notify maintenance.	Stop Vehicle Immediately Communication, ECU 792 - steering computer not responding Circuit breaker tripped. Cable defective. ECU 792 defective.	Steering may not function properly.
111		Stop Vehicle Abort mission. Notify maintenance.	Stop Vehicle Immediately Communication, ECU 793 - transmission computer not responding Circuit breaker tripped. Cable defective. ECU 793 defective.	Transmission may not function properly.
112		Stop Vehicle Abort mission. Notify maintenance.	Stop Vehicle Immediately ECU 794 - engine computer not responding Circuit breaker tripped. Cable defective. ECU 794 defective.	Engine may not function properly.
118		Stop Vehicle Put load down safely. Abort mission. Notify maintenance.	Stop Vehicle Immediately No pressure/signal - both brake systems Circuit breaker tripped. Hydraulic failure.	Brakes may not function properly.

Table 1. Error Codes - Continued.

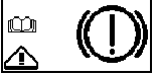
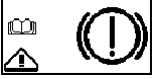

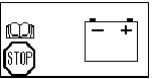
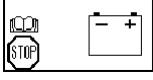
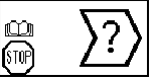
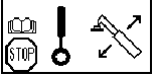
ERROR CODE	DISPLAY LAYOUT	DRIVER ACTION	ERROR CODE CATEGORY/ EXPLANATION	VEHICLE LIMITATIONS
119		Stop Vehicle Press RESET. Finish mission. Notify maintenance.	Warning - Degraded Operation No pressure - brake circuit 1 Hydraulic failure.	Only half brake capability available.
120		Stop Vehicle Press RESET. Finish mission. Notify maintenance.	Warning - Degraded Operation No pressure - brake circuit 2 Hydraulic failure.	Only half brake capability available.
121		Stop Vehicle Put load down safely. Abort mission. Notify maintenance.	Stop Vehicle Immediately Supply voltage - ECU 790 Emergency stop engaged. Circuit breaker tripped. Cable defective.	Operating system and boom function not working.
122		Stop Vehicle Put load down safely. Abort mission. Notify maintenance.	Stop Vehicle Immediately Supply voltage - CAN 790 Circuit breaker tripped. Cable defective.	Operating system and boom function not working.
123		Stop Vehicle Put load down safely. Abort mission. Notify maintenance.	Stop Vehicle Immediately Ref. voltages 10V - ECU 790 Circuit breaker tripped. Cable defective.	Operating system and boom function not working.
125		Stop Vehicle Shut engine OFF/ON. If code clears, resume mission. If code remains, notify maintenance.	Stop Vehicle Immediately Memory fault, check ECU 790 Circuit breaker tripped. Cable defective.	None if code clears. Operating system and boom function not working.
126		Stop Vehicle Put load down safely. Abort mission. Notify maintenance.	Stop Vehicle Immediately Signal for lifting/lowering, out of range Cable defective. Short circuit. Potentiometer in joystick not functioning.	Lift/lower does not function properly (hydraulic stops).

Table 1. Error Codes - Continued.

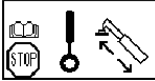
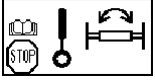
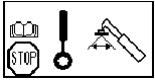

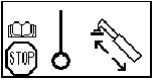
ERROR CODE	DISPLAY LAYOUT	DRIVER ACTION	ERROR CODE CATEGORY/ EXPLANATION	VEHICLE LIMITATIONS
127		Stop Vehicle Put load down safely. Abort mission. Notify maintenance.	Stop Vehicle Immediately Signal for boom in/out, out of range Cable defective. Short circuit. Potentiometer in joystick not functioning.	Boom in/out does not function properly (hydraulic stops).
128		Stop Vehicle Put load down safely. Abort mission. Notify maintenance.	Stop Vehicle Immediately Signal for slewing, out of range Cable defective. Short circuit. Potentiometer in joystick not functioning.	Slewing does not function properly (hydraulic stops).
129		Stop Vehicle Put load down safely. Abort mission. Notify maintenance.	Stop Vehicle Immediately Signal for tilt in/out, out of range Cable defective. Short circuit. Potentiometer in joystick not functioning.	Tilt does not function properly (hydraulic stops).
130		Stop Vehicle Put load down safely. Abort mission. Notify maintenance.	Stop Vehicle Immediately Overload protection error Error codes 131 - 136 or 210 have been active.	No overload protection system. Reduced hydraulic speed.
131		Stop Vehicle Press RESET. Put load down safely. Abort mission. Notify maintenance.	Stop Vehicle Immediately Boom sensor - boom length out of range or no signal change when boom is moving Cable defective. Short circuit. Potentiometer damaged. Hydraulic failure.	No overload protection system. Reduced hydraulic speed.

Table 1. Error Codes - Continued.


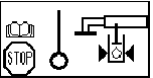
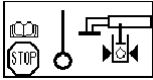
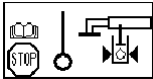
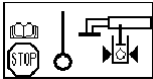
ERROR CODE	DISPLAY LAYOUT	DRIVER ACTION	ERROR CODE CATEGORY/ EXPLANATION	VEHICLE LIMITATIONS
132		Stop Vehicle Press RESET. Put load down safely. Abort mission. Notify maintenance.	Stop Vehicle Immediately Boom sensor - boom angle out of range or no signal change when lowering/lifting boom Sensor bracket or lever damaged. Cable defective. Short circuit. Potentiometer damaged. Hydraulic failure.	No overload protection system. Reduced hydraulic speed.
133		Stop Vehicle Press RESET. Put load down safely. Abort mission. Notify maintenance.	Stop Vehicle Immediately Left lift cylinder pressure sensor, signal out of range Cable defective. Short circuit. Pressure sensor defective.	No overload protection system. Reduced hydraulic speed.
134		Stop Vehicle Press RESET. Put load down safely. Abort mission. Notify maintenance.	Stop Vehicle Immediately Right lift cylinder pressure sensor, signal out of range Cable defective. Short circuit. Pressure sensor defective.	No overload protection system. Reduced hydraulic speed.
135		Stop Vehicle Press RESET. Put load down safely. Abort mission. Notify maintenance.	Stop Vehicle Immediately Left lift cylinder return pressure sensor, signal out of range Cable defective. Short circuit. Pressure sensor defective.	No overload protection system. Reduced hydraulic speed.
136		Stop Vehicle Press RESET. Put load down safely. Abort mission. Notify maintenance.	Stop Vehicle Immediately Right lift cylinder return pressure sensor, signal out of range Cable defective. Short circuit. Pressure sensor defective.	No overload protection system. Reduced hydraulic speed.

Table 1. Error Codes - Continued.

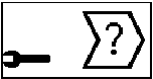
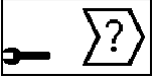
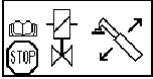
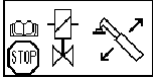
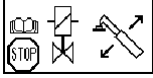
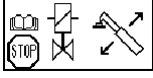
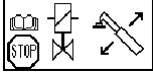
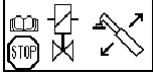
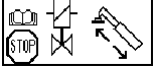
ERROR CODE	DISPLAY LAYOUT	DRIVER ACTION	ERROR CODE CATEGORY/ EXPLANATION	VEHICLE LIMITATIONS
141		Finish Mission Shut engine OFF/ON. If code clears, resume mission. If code remains, notify maintenance.	Information/Maintenance Communication fault - ECU 790 Computer hardware fault.	Possible ECU malfunction. Other codes will also show.
142		Finish Mission Shut engine OFF/ON. If code clears, resume mission. If code remains, notify maintenance.	Information/Maintenance Communication fault - ECU 790 Computer hardware fault.	Possible ECU malfunction. Other codes will also show.
151		Stop Vehicle Put load down safely. Abort mission. Notify maintenance.	Stop Vehicle Immediately Locking valve, broken circuit Cable to valve defective.	Boom cannot be lowered with joystick. Emergency lowering is necessary.
152		Stop Vehicle Put load down safely. Abort mission. Notify maintenance.	Stop Vehicle Immediately Locking valve, short circuit Cable to valve defective.	Boom cannot be lowered with joystick. Emergency lowering is necessary.
154		Stop Vehicle Put load down safely. Abort mission. Notify maintenance.	Stop Vehicle Immediately Lifting valve, broken circuit Cable to valve defective.	Lifting is impossible.
155		Stop Vehicle Put load down safely. Abort mission. Notify maintenance.	Stop Vehicle Immediately Lifting valve, short circuit Cable to valve defective.	Uncontrolled self-lifting may occur.
157		Stop Vehicle Put load down safely. Abort mission. Notify maintenance.	Stop Vehicle Immediately Lowering valve, broken circuit Cable to valve defective.	Boom cannot be lowered with joystick. Emergency lowering is necessary.
158		Stop Vehicle Put load down safely. Abort mission. Notify maintenance.	Stop Vehicle Immediately Lowering valve, short circuit Cable to valve defective.	Boom cannot be lowered with joystick. Emergency lowering is necessary. Uncontrolled self-lifting may occur.
160		Stop Vehicle Put load down safely. Abort mission. Notify maintenance.	Stop Vehicle Immediately Boom in valve, broken circuit Cable to valve defective.	Boom cannot be retracted.

Table 1. Error Codes - Continued.

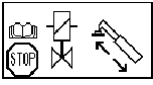
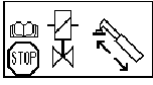
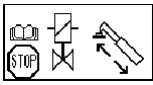
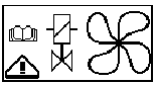
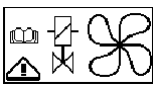
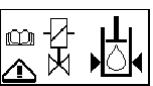
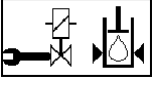

ERROR CODE	DISPLAY LAYOUT	DRIVER ACTION	ERROR CODE CATEGORY/ EXPLANATION	VEHICLE LIMITATIONS
161		Stop Vehicle Put load down safely. Abort mission. Notify maintenance.	Stop Vehicle Immediately Boom in valve, short circuit Cable to valve defective.	Boom cannot be retracted. Uncontrolled self-retraction may occur.
163		Stop Vehicle Put load down safely. Abort mission. Notify maintenance.	Stop Vehicle Immediately Boom out valve, broken circuit Cable to valve defective.	Boom cannot be extended.
164		Stop Vehicle Put load down safely. Abort mission. Notify maintenance.	Stop Vehicle Immediately Boom out valve, short circuit Cable to valve defective.	Boom cannot be extended. Uncontrolled self-extension may occur.
166		Press RESET Finish mission. Notify maintenance.	Warning - Degraded Operation Cooling fan valve, broken circuit Cable to valve defective.	Cooling fan will run at full speed. No fording activities possible.
167		Press RESET Finish mission. Notify maintenance.	Warning - Degraded Operation Cooling fan valve, short circuit Cable to valve defective.	Cooling fan may run at any speed. No fording activities possible. Overheating may occur.
169		Press RESET Finish mission. Notify maintenance.	Warning - Degraded Operation Emergency hydraulic valve, broken circuit Cable to valve defective.	No hydraulic emergency operation is possible.
172		Press RESET Finish mission. Notify maintenance.	Information/Maintenance Pump turn off valve, broken circuit Cable defective.	May be difficult to start because of engaged pumps.
191		Stop Vehicle Abort mission. Notify maintenance.	Stop Vehicle Immediately Temperature in front wheel end above 203°F (95°C) Cable defective. No cooling.	Brakes may overheat at front axle.

Table 1. Error Codes - Continued.



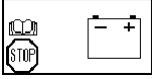
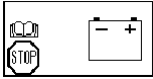
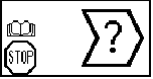
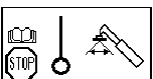
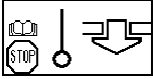
ERROR CODE	DISPLAY LAYOUT	DRIVER ACTION	ERROR CODE CATEGORY/ EXPLANATION	VEHICLE LIMITATIONS
192		Stop Vehicle Abort mission. Notify maintenance.	Stop Vehicle Immediately Temperature in rear wheel end above 203°F (95°C) Cable defective. No cooling.	Brakes may overheat at rear axle.
201		Stop Vehicle Put load down safely. Abort mission. Notify maintenance.	Stop Vehicle Immediately Supply voltage, ECU 791 Emergency stop engaged. Circuit breaker tripped. Cable defective.	Tophandler not working.
202		Stop Vehicle Put load down safely. Abort mission. Notify maintenance.	Stop Vehicle Immediately Supply voltage, CAN 791 Circuit breaker tripped. Cable defective.	Operating system and tophandler not working.
203		Stop Vehicle Put load down safely. Abort mission. Notify maintenance.	Stop Vehicle Immediately Ref. voltages 10V- 791 Circuit breaker tripped. Cable defective.	Operating system not working.
205		Stop Vehicle Shut engine OFF/ON. If code clears, resume mission. If code remains, notify maintenance.	Stop Vehicle Immediately Memory fault - check ECU 791 Circuit breaker tripped. Cable defective.	None if code clears. Operating system and tophandler not working.
210		Stop Vehicle Press RESET. Put load down safely. Abort mission. Notify maintenance.	Stop Vehicle Immediately Tilt angle sensor, signal out of range Potentiometer damaged. Cable defective. Short circuit.	Generate error code 130.
212		Stop Vehicle Abort mission. Notify maintenance.	Stop Vehicle Immediately Logical error - left twistlock Short circuit. Signal from both 7204L and 7205L.	Both locked and unlocked twistlock at the same time. Safe operation is not possible.

Table 1. Error Codes - Continued.

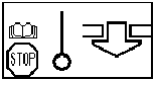
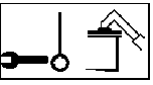
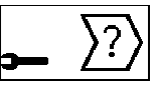
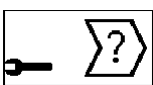
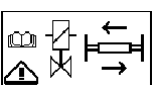
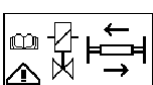
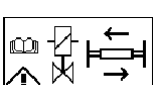
ERROR CODE	DISPLAY LAYOUT	DRIVER ACTION	ERROR CODE EXPLANATION	VEHICLE LIMITATIONS
213		Stop Vehicle Abort mission. Notify maintenance.	Stop Vehicle Immediately Logical error - right twistlock Short circuit. Signal from both 7204R and 7205R.	Both locked and unlocked twistlock at the same time. Safe operation is not possible.
214		Stop Vehicle Press RESET. Abort mission. Notify maintenance.	Stop Vehicle Immediately Logical error - forklift sensors Cable defective. Signal from 7206-1 or 7206-2.	Operation of forklift is not possible.
220		Stop Vehicle Press RESET. Finish mission. Notify maintenance.	Warning - Degraded Operation One pulse signal to the steering wheel interrupted Clock 1. Clock 2. Cables defective. Steering column sensor defective.	Stop vehicle by switching to neutral. Steering system will operate but is not redundant. The steering computer uses non interrupted signal to steer the vehicle.
221		Finish Mission Shut engine OFF/ON. If code clears, resume mission. If code remains, notify maintenance.	Information/Maintenance Communication fault - ECU 791, connector 2 Computer hardware fault.	Possible ECU malfunction. Other codes will also show.
225		Press RESET Finish mission. Notify maintenance.	Warning - Degraded Operation Left sideshift, open circuit Cable to valve defective.	Left sideshift is not possible.
226		Press RESET Finish mission. Notify maintenance.	Warning - Degraded Operation Left sideshift, short circuit Cable to valve defective.	Uncontrolled left sideshift may occur.
228		Press RESET Finish mission. Notify maintenance.	Warning - Degraded Operation Right sideshift, open circuit Cable to valve defective.	Right sideshift is not possible.

Table 1. Error Codes - Continued.

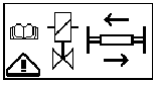
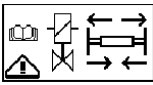
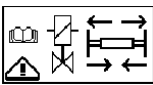
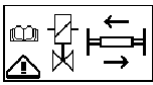
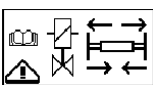
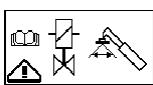
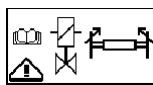
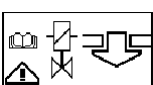
ERROR CODE	DISPLAY LAYOUT	DRIVER ACTION	ERROR CODE EXPLANATION	VEHICLE LIMITATIONS
229		Press RESET Finish mission. Notify maintenance.	Warning - Degraded Operation Right sideshift, short circuit Cable to valve defective.	Uncontrolled right sideshift may occur.
231		Press RESET Finish mission. Notify maintenance.	Warning - Degraded Operation 20 to 40 valve, open circuit Cable to valve defective.	Spreading from 20 to 40 ft is not possible.
232		Press RESET Finish mission. Notify maintenance.	Warning - Degraded Operation 20 to 40 valve, short circuit Cable to valve defective.	Spreading from 20 to 40 ft is not possible.
234		Press RESET Finish mission. Notify maintenance.	Warning - Degraded Operation 40 to 20 valve, open circuit Cable to valve defective.	Spreading from 40 to 20 ft is not possible.
235		Press RESET Finish mission. Notify maintenance.	Warning - Degraded Operation 40 to 20 valve, short circuit Cable to valve defective.	Spreading from 20 to 40 ft is not possible.
237		Press RESET Finish mission. Notify maintenance.	Warning - Degraded Operation Active tilt valve, open circuit Cable to valve defective.	Tophandler locked, not automatically leveled.
240		Press RESET Finish mission. Notify maintenance.	Warning - Degraded Operation Active pile slope, open circuit Cable to valve defective.	Tophandler locked, not free oscillated.
243		Press RESET Finish mission. Notify maintenance.	Warning - Degraded Operation Twistlock valve lock, open circuit Cable to valve defective.	Impossible to lock twistlock.

Table 1. Error Codes - Continued.

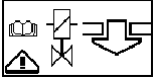
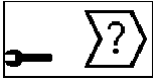
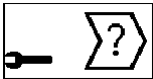
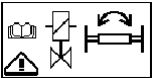
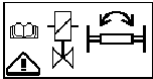
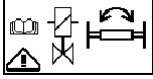
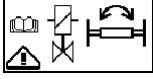
ERROR CODE	DISPLAY LAYOUT	DRIVER ACTION	ERROR CODE EXPLANATION	VEHICLE LIMITATIONS
246		Press RESET Finish mission. Notify maintenance.	Warning - Degraded Operation Twistlock valve unlock, open circuit Cable to valve defective.	Impossible to unlock twistlock.
250		Finish Mission Shut engine OFF/ON. If code clears, resume mission. If code remains, notify maintenance.	Information/Maintenance Communication fault - ECU 791, connector 3 Computer hardware fault.	Possible ECU malfunction. Other codes will also show.
251		Finish Mission Shut engine OFF/ON. If code clears, resume mission. If code remains, notify maintenance.	Information/Maintenance Communication fault - ECU 791, connector 3 Computer hardware fault.	Possible ECU malfunction. Other codes will also show.
255		Press RESET Finish mission. Notify maintenance.	Warning - Degraded Operation Slewing clockwise valve, open circuit Cable to valve defective.	Slewing clockwise is not possible.
256		Press RESET Finish mission. Notify maintenance.	Warning - Degraded Operation Slewing clockwise valve, short circuit Cable to valve defective.	Uncontrolled slewing may occur.
258		Press RESET Finish mission. Notify maintenance.	Warning - Degraded Operation Slewing counterclockwise valve, open circuit Cable to valve defective.	Slewing clockwise is not possible.
259		Press RESET Finish mission. Notify maintenance.	Warning - Degraded Operation Slewing counterclockwise valve, short circuit Cable to valve defective.	Uncontrolled slewing may occur.

Table 1. Error Codes - Continued.

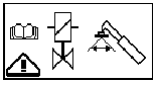
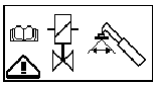
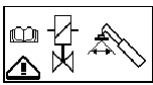
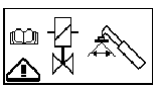
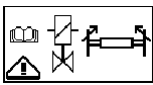
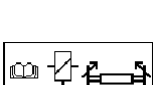

ERROR CODE	DISPLAY LAYOUT	DRIVER ACTION	ERROR CODE EXPLANATION	VEHICLE LIMITATIONS
261		Press RESET Finish mission. Notify maintenance.	Warning - Degraded Operation Tilt out valve, open circuit Cable to valve defective.	Tilt out is not possible.
262		Press RESET Finish mission. Notify maintenance.	Warning - Degraded Operation Tilt out valve, short circuit Cable to valve defective.	Uncontrolled tilt may occur.
264		Press RESET Finish mission. Notify maintenance.	Warning - Degraded Operation Tilt in valve, open circuit Cable to valve defective.	Tilt in is not possible.
265		Press RESET Finish mission. Notify maintenance.	Warning - Degraded Operation Tilt in valve, short circuit Cable to valve defective.	Uncontrolled tilt may occur.
267		Press RESET Finish mission. Notify maintenance.	Warning - Degraded Operation Right oscillation valve, open circuit Cable to valve defective.	Right oscillation (leveling) is not possible.
268		Press RESET Finish mission. Notify maintenance.	Warning - Degraded Operation Right oscillation valve, short circuit Cable to valve defective.	Uncontrolled oscillation (leveling) may occur.
270		Press RESET Finish mission. Notify maintenance.	Warning - Degraded Operation Left oscillation valve, open circuit Cable to valve defective.	Left oscillation (leveling) is not possible.

Table 1. Error Codes - Continued.

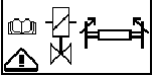
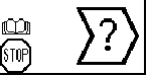


ERROR CODE	DISPLAY LAYOUT	DRIVER ACTION	ERROR CODE EXPLANATION	VEHICLE LIMITATIONS
271		Press RESET Finish mission. Notify maintenance.	Warning - Degraded Operation Left oscillation valve, short circuit Cable to valve defective.	Uncontrolled oscillation (leveling) may occur.
300		Stop Vehicle Shut engine off for 30 seconds then start vehicle. If code clears, resume mission. If code remains, notify maintenance.	Stop Vehicle Immediately Steering system malfunction Steering computer - hardware error (EPROM, watchdog, reference voltages, etc.)	No steering and driving functions are available.
301		Stop Vehicle Press RESET. Finish mission. Notify maintenance.	Warning - Degraded Operation One track of actual value potentiometer out of range (e.g., cable interrupted)	Stop vehicle by switching to neutral. Steering system will operate but is not redundant.
302			Wheel 1, track 1.	
303			Wheel 2, track 1.	
304			Wheel 3, track 1.	
305			Wheel 4, track 1.	
306			Wheel 1, track 2.	
307			Wheel 2, track 2.	
308			Wheel 3, track 2. Wheel 4, track 2.	
309		Stop Vehicle Abort mission. Notify maintenance.	Stop Vehicle Immediately Both tracks of actual value potentiometer out of range	Stop vehicle by switching to neutral. The faulty wheel is locked immediately. Other wheels remain operational.
310			Wheel 1.	
311			Wheel 2.	
312			Wheel 3. Wheel 4.	

Table 1. Error Codes - Continued.



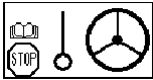

ERROR CODE	DISPLAY LAYOUT	DRIVER ACTION	ERROR CODE EXPLANATION	VEHICLE LIMITATIONS
313 314 315 316		Stop Vehicle Abort mission. Notify maintenance.	Stop Vehicle Immediately Deviation between two potentiometer tracks, but both inside tolerance range Wheel 1. Wheel 2. Wheel 3. Wheel 4.	Stop vehicle by switching to neutral. Steering system will operate but is not redundant.
317 318 319 320		Stop Vehicle Check wheel for blockage. If blocked, remove blockage and press RESET. If not blocked, notify maintenance.	Stop Vehicle Immediately Steering deviation between set point and actual value (tracking error) Wheel 1. Wheel 2. Wheel 3. Wheel 4.	Stop vehicle by switching to neutral. Steering remains active and tries to close up to set point. System will be active as soon as deviating wheel has closed up.
321 322 323 324		Stop Vehicle Notify maintenance.	Stop Vehicle Immediately Wheel alignment values out of range Wheel 1. Wheel 2. Wheel 3. Wheel 4.	This error prohibits driving after steering calibration if calibration was not successful or calibration values are out of range.
325 326 327 328		Stop Vehicle Notify maintenance.	Stop Vehicle Immediately Break in cable to proportional valve Wheel 1. Wheel 2. Wheel 3. Wheel 4.	Stop vehicle by switching to neutral. Steering computer cannot control wheel with broken cable. Faulty wheel has to be aligned by manual operation of valve.

Table 1. Error Codes - Continued.

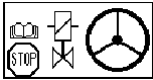

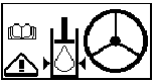
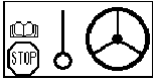
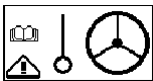

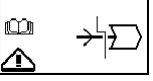
ERROR CODE	DISPLAY LAYOUT	DRIVER ACTION	ERROR CODE EXPLANATION	VEHICLE LIMITATIONS
329 330 331 332		Stop Vehicle Abort mission. Notify maintenance.	Stop Vehicle Immediately Cable to proportional valve, short circuit Wheel 1. Wheel 2. Wheel 3. Wheel 4.	Stop vehicle by switching to neutral. Steering computer cannot control wheel with broken cable. Faulty wheel has to be aligned by manual operation of valve.
339		Stop Vehicle Abort mission. Notify maintenance.	Information/Maintenance	Grounding of steering wheel sensor broken.
340		Stop Vehicle Press RESET. Finish mission. Notify maintenance.	Warning - Degraded Operation Supply pressure below 1,450 psi (100 bar) Leaking hydraulics.	Stop vehicle by switching to neutral. Steering system will operate in a degraded mode.
341		Stop Vehicle Abort mission. Notify maintenance.	Stop Vehicle Immediately Steering wheel signals inconsistent (e.g., two incremental counters deviating) Cables defective. Steering column sensor defective.	Stop vehicle by switching to neutral. Steering system will operate but is not redundant. Steering computer uses one of two counters to steer vehicle.
342 343		Stop Vehicle Press RESET. Finish mission. Notify maintenance.	Warning - Degraded Operation One pulse signal to steering wheel interrupted Cables defective. Steering column sensor defective.	Stop vehicle by switching to neutral. Steering system will operate but is not redundant. Steering computer uses non interrupted signal to steer vehicle.
344		Stop Vehicle Abort mission. Notify maintenance.	Stop Vehicle Immediately Both pulse signals to steering wheel interrupted Cables defective. Steering column sensor defective.	Stop vehicle by switching to neutral. Steering system will not operate.
345		Finish Mission Shut engine OFF/ON. If code clears, resume mission. If code remains, notify maintenance.	Warning - Degraded Operation No CAN communication to display Cable defective.	Error codes from steering ECU will not show. Steering function is operational.

Table 1. Error Codes - Continued.

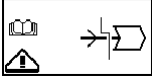
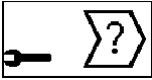
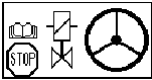


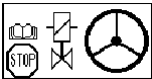
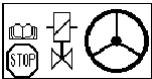
ERROR CODE	DISPLAY LAYOUT	DRIVER ACTION	ERROR CODE EXPLANATION	VEHICLE LIMITATIONS
346		Finish Mission Shut engine OFF/ON. If code clears, resume mission. If code remains, notify maintenance.	Warning - Degraded Operation No CAN communication to transmission Cables defective.	It is not possible to change from 2WD to 4WD or vice versa. The whole steering system remains operational, but steering features dependant on driving speed are not available. To keep vehicle in full operation, steering program selection is allowed at this time.
347		Select Steering Mode	Information/Maintenance No valid steering program selected	None.
350		Finish Mission Notify maintenance.	Information/Maintenance Appears when solenoid or circuit resistance is out of preset range.	None.
351		Finish Mission Notify maintenance.	Information/Maintenance Appears when solenoid or circuit resistance is out of preset range.	None.
352		Finish Mission Notify maintenance.	Information/Maintenance Appears when solenoid or circuit resistance is out of preset range.	None.
353		Finish Mission Notify maintenance.	Information/Maintenance Appears when solenoid or circuit resistance is out of preset range.	None.
354		Finish Mission Notify maintenance.	Information/Maintenance Appears when solenoid or circuit resistance is out of preset range.	None.

Table 1. Error Codes - Continued.

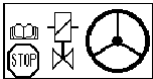
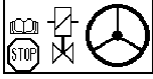

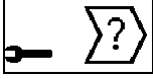
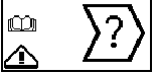
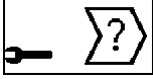
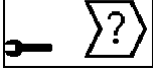
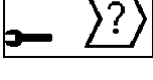
ERROR CODE	DISPLAY LAYOUT	DRIVER ACTION	ERROR CODE EXPLANATION	VEHICLE LIMITATIONS
355		Finish Mission Notify maintenance.	Information/Maintenance Appears when solenoid or circuit resistance is out of preset range.	None.
356		Finish Mission Notify maintenance.	Information/Maintenance Appears when solenoid or circuit resistance is out of preset range.	None.
357		Finish Mission Notify maintenance.	Information/Maintenance Appears when solenoid or circuit resistance is out of preset range.	None.
399		Finish Mission Notify maintenance.	Information/Maintenance Appears when solenoid or circuit resistance is out of preset range.	None.
401		Stop Vehicle Press RESET. Finish mission. Notify maintenance.	Warning - Degraded Operation Digital output short circuit - "Enable driving" (no neutral gear from steering ECU) Cables defective.	Transmission will not go into neutral automatically.
404		Finish Mission Notify maintenance.	Information/Maintenance Digital output short circuit - "Control lamp, front wheel steering" Cables defective.	Control lamp at steering selection switch is not working.
405		Finish Mission Notify maintenance.	Information/Maintenance Digital output short circuit - "Control lamp, four wheel steering" Cables defective.	Control lamp at steering selection switch is not working.
406		Finish Mission Notify maintenance.	Information/Maintenance Digital output short circuit - "Control lamp, crab steering" Cables defective.	Control lamp at steering selection switch is not working.

Table 1. Error Codes - Continued.

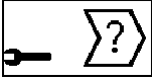
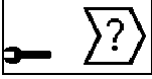
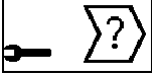
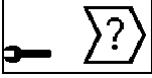
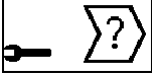
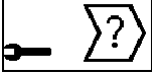
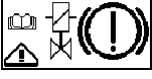
ERROR CODE	DISPLAY LAYOUT	DRIVER ACTION	ERROR CODE EXPLANATION	VEHICLE LIMITATIONS
408		Finish Mission Notify maintenance.	Information/Maintenance Digital output short circuit - "Control lamp, unlocked twistlock" Cables defective.	Control lamp at steering column is not working.
409		Finish Mission Notify maintenance.	Information/Maintenance Digital output short circuit - "Control lamp, locked twistlock" Cables defective.	Control lamp at steering column is not working.
410		Finish Mission Notify maintenance.	Information/Maintenance Digital output short circuit - "Control lamp, alignment" Cables defective.	Control lamp at steering column is not working.
411		Finish Mission Notify maintenance.	Information/Maintenance Digital output short circuit - "Auxiliary hydraulic pump" Cables defective.	Cab cannot be moved. No emergency operation of boom or tophandler available.
412		Finish Mission Notify maintenance.	Information/Maintenance Digital output short circuit - "Ether start kit" Cables defective.	Ether start not working.
413		Finish Mission Notify maintenance.	Information/Maintenance Digital output short circuit - "Oil supply valve, boom folding" Cables defective.	Boom cannot be folded.
414		Stop Vehicle Press RESET. Finish mission. Notify maintenance.	Warning - Degraded Operation Digital output short circuit - "Drive axle cooling, bypass valves" Cables defective.	Brakes may be overheated. Error codes 191 and 192 will show if brakes have overheated.

Table 1. Error Codes - Continued.

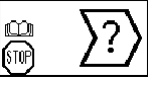
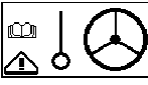
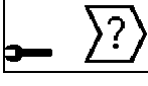


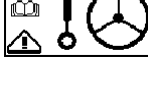
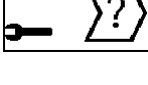
ERROR CODE	DISPLAY LAYOUT	DRIVER ACTION	ERROR CODE EXPLANATION	VEHICLE LIMITATIONS
415		Stop Vehicle Notify maintenance.	Operation Digital output short circuit - "Drag restriction Pin 792.57" Cables defective.	
416		Stop Vehicle Press RESET. Finish mission. Notify maintenance.	Warning - Degraded Operation Digital input not read correctly - "Steering pressure" Cables defective.	A steering pressure failure cannot be detected, error code 340.
417		Finish Mission Notify maintenance.	Information/Maintenance Digital input not read correctly - "Auxiliary hydraulic pump switch" Cables defective.	Auxiliary hydraulic pump cannot be started.
418		Stop Vehicle Press RESET. Finish mission. Notify maintenance.	Warning - Degraded Operation Digital input not read correctly - "Front wheel steering switch" Cables defective.	2WD cannot be selected.
419		Stop Vehicle Press RESET. Finish mission. Notify maintenance.	Warning - Degraded Operation Digital input not read correctly - "Four wheel steering switch" Cables defective.	4WD cannot be selected.
420		Stop Vehicle Press RESET. Finish mission. Notify maintenance.	Warning - Degraded Operation Digital input not read correctly - "Crab steering switch" Cables defective.	Crab steering cannot be selected.
422		Finish Mission Notify maintenance.	Information/Maintenance Digital input not read correctly - "Sensor, cab in transport position" Cables defective. Steering computer damaged.	Boom folding is not possible.

Table 1. Error Codes - Continued.

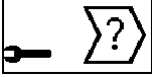
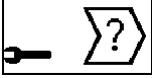
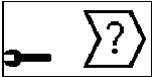



ERROR CODE	DISPLAY LAYOUT	DRIVER ACTION	ERROR CODE EXPLANATION	VEHICLE LIMITATIONS
423		Finish Mission Notify maintenance.	Information/Maintenance Digital input not read correctly - "Ether start switch" Cables defective. Steering computer damaged.	Ether injection is not possible.
426		Stop Vehicle Press RESET. Finish mission. Notify maintenance.	Warning - Degraded Operation Digital input not read correctly - "Fording level switch" Cables defective. Steering computer damaged.	Fording operations are not possible.
427		Finish Mission Notify maintenance.	Information/Maintenance Digital input not read correctly - "Tophandler working light switch" Cables defective. Steering computer damaged.	Working lights on tophandler do not function.
432		Finish Mission Notify maintenance.	Information/Maintenance Digital input not read correctly - "Hydraulic filter indication (lift/lower, boom in/out)" Cables defective. Steering computer damaged.	None.
433		Finish Mission Notify maintenance.	Information/Maintenance Digital input not read correctly - "Hydraulic filter indication, steering" Cables defective. Steering computer damaged.	None.
434		Finish Mission Notify maintenance.	Information/Maintenance Digital input not read correctly - "Hydraulic filter indication, tophandler" Cables defective. Steering computer damaged.	None.

Table 1. Error Codes - Continued.

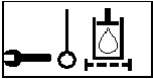

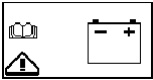
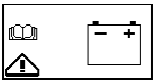
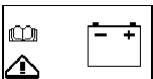
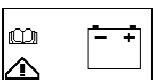
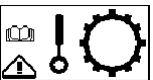
ERROR CODE	DISPLAY LAYOUT	DRIVER ACTION	ERROR CODE EXPLANATION	VEHICLE LIMITATIONS
435		Finish Mission Notify maintenance.	Information/Maintenance Digital input not read correctly - "Hydraulic filter indication, return oil" Cables defective. Steering computer damaged.	None.
450		Stop Vehicle Press RESET. Finish mission. Notify maintenance.	Warning - Degraded Operation Ambient temperature too high Temperature sensor defective. ECU 792 defective.	None.
451		Stop Vehicle Press RESET. Finish mission. Notify maintenance.	Warning - Degraded Operation Supply voltage too high Alternator defective.	Stop vehicle by switching to neutral.
452		Stop Vehicle Press RESET. Finish mission. Notify maintenance.	Warning - Degraded Operation Supply voltage too low Power supply off. Alternator defective.	Stop vehicle by switching to neutral.
453		Stop Vehicle Press RESET. Finish mission. Notify maintenance.	Supply voltage for wheel sensors track 2 is out of range.	Stop vehicle by switching to neutral. If error code 454 also is active, all wheels are locked.
454		Stop Vehicle Press RESET. Finish mission. Notify maintenance.	Supply voltage for wheel sensors track 1 is out of range.	Stop vehicle by switching to neutral. If error code 453 also is active, all wheels are locked.
618		Stop Vehicle Press RESET. If error shows again, notify maintenance. Finish mission.	Warning - Degraded Operation Logical error at direction select signal, transmission ECU detected a wrong signal combination for the direction Cables defective. Shift lever defective.	Stop vehicle by switching to neutral.

Table 1. Error Codes - Continued.


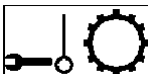

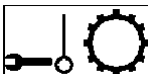
ERROR CODE	DISPLAY LAYOUT	DRIVER ACTION	ERROR CODE EXPLANATION	VEHICLE LIMITATIONS
622		Press RESET If error shows again, notify maintenance. Finish mission.	Information/Maintenance Logical error at axle connection, feedback axle connection measured by transmission ECU and output signal action connection do not match Cables defective. Switch defective. Mechanical error.	When shifting from 2WD to 4WD or vice versa, engage forward drive and immediately return to neutral. Turn the ignition switch off for at least 30 seconds, then turn switch back on.
637		Finish Mission Notify maintenance.	Information/Maintenance Short circuit to battery voltage or open circuit at transmission sump temperature sensor input, voltage too high Cables defective. Sensor defective. Connector pin broken.	None.
638		Finish Mission Notify maintenance.	Information/Maintenance Short circuit to ground at transmission sump temperature sensor input, voltage too low Cables defective. Sensor defective. Connector pin broken.	None.
639		Finish Mission Notify maintenance.	Information/Maintenance Short circuit to battery voltage or open circuit at converter output temperature sensor input, voltage too high Cables defective. Sensor defective. Connector pin broken.	None.

Table 1. Error Codes - Continued.





ERROR CODE	DISPLAY LAYOUT	DRIVER ACTION	ERROR CODE EXPLANATION	VEHICLE LIMITATIONS
640		Finish Mission Notify maintenance.	Information/Maintenance Short circuit to battery voltage or open circuit at converter output temperature sensor input, voltage too low Cables defective. Sensor defective. Connector pin broken.	None.
649		Finish Mission Notify maintenance.	Information/Maintenance Short circuit to battery voltage or open circuit at engine speed input, transmission ECU measures a voltage higher than 7.0V at speed input pin Cables defective. Sensor defective. Connector pin broken.	Gearshift quality is reduced due to another control mode. (Operating mode: substitute clutch control).
650		Finish Mission Notify maintenance.	Information/Maintenance Short circuit to ground at engine speed input, transmission ECU measures a voltage less than 0.45V at speed input pin Cables defective. Sensor defective.	Gearshift quality is reduced due to another control mode. (Operating mode: substitute clutch control).
651		Finish Mission Notify maintenance.	Information/Maintenance Logical error at engine speed input, transmission ECU measures engine speed over a threshold and the next moment the measured speed is zero Cables defective. Sensor defective. Incorrect sensor gap size.	Gearshift quality is reduced due to another control mode. (Operating mode: substitute clutch control).

Table 1. Error Codes - Continued.





ERROR CODE	DISPLAY LAYOUT	DRIVER ACTION	ERROR CODE EXPLANATION	VEHICLE LIMITATIONS
652		Press RESET Finish mission. Notify maintenance.	Warning - Degraded Operation Short circuit to battery voltage or open circuit at turbine speed input, transmission ECU measures a voltage higher than 7.0V at speed input pin Cables defective. Sensor defective. Incorrect sensor gap size.	Gearshift quality is reduced due to another control mode. (Operating mode: substitute clutch control). If there is also a failure at output speed, transmission ECU shifts to neutral. Limp home.
653		Press RESET Finish mission. Notify maintenance.	Warning - Degraded Operation Short circuit to ground at turbine speed input, transmission ECU measures a voltage less than 0.45V at speed input pin Cables defective. Sensor defective.	Gearshift quality is reduced due to another control mode. (Operating mode: substitute clutch control). If there is also a failure at output speed, transmission ECU shifts to neutral. Limp home.
654		Press RESET Finish mission. Notify maintenance.	Warning - Degraded Operation Logical error at turbine speed input, transmission ECU measures turbine speed over a threshold and at the next moment the measured speed is zero Cables defective. Sensor defective. Incorrect sensor gap size.	Gearshift quality is reduced due to another control mode. (Operating mode: substitute clutch control). If there is also a failure at output speed, transmission ECU shifts to neutral. Limp home.
655		Finish Mission Notify maintenance.	Information/Maintenance Short circuit to battery voltage or open circuit at internal speed input, transmission ECU measures a voltage higher than 7.0V at speed input pin Cables defective. Sensor defective.	Gearshift quality is reduced due to another control mode. (Operating mode: substitute clutch control).

Table 1. Error Codes - Continued.





ERROR CODE	DISPLAY LAYOUT	DRIVER ACTION	ERROR CODE EXPLANATION	VEHICLE LIMITATIONS
656		Finish Mission Notify maintenance.	Information/Maintenance Short circuit to ground at internal speed input, transmission ECU measures a voltage less than 0.45V at speed input pin Cables defective. Sensor defective.	Gearshift quality is reduced due to another control mode. (Operating mode: substitute clutch control).
657		Press RESET Finish mission. Notify maintenance.	Information/Maintenance Logical error at internal speed input, transmission ECU measures internal speed over a threshold and at the next moment the measured speed is zero Cables defective. Sensor defective. Incorrect sensor gap size.	Gearshift quality is reduced due to another control mode. (Operating mode: substitute clutch control). If there is also a failure at output speed, transmission ECU shifts to neutral. Limp home.
658		Stop Vehicle Press RESET. Finish mission. Notify maintenance.	Warning - Degraded Operation Short circuit to battery voltage or open circuit at output speed input, transmission ECU measures a voltage higher than 12.5V at speed input pin Cables defective. Sensor defective.	Gearshift quality is reduced due to another control mode. (Operating mode: substitute clutch control). If there is also a failure at turbine speed, transmission ECU shifts to neutral. Limp home.
659		Stop Vehicle Press RESET. Finish mission. Notify maintenance.	Warning - Degraded Operation Short circuit to battery voltage at output speed input, transmission ECU measures a voltage less than 1.0V at speed input pin Cables defective. Sensor defective.	Gearshift quality is reduced due to another control mode. (Operating mode: substitute clutch control). If there is also a failure at turbine speed, transmission ECU shifts to neutral. Limp home.

Table 1. Error Codes - Continued.



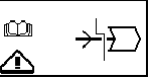
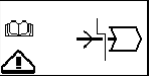
ERROR CODE	DISPLAY LAYOUT	DRIVER ACTION	ERROR CODE EXPLANATION	VEHICLE LIMITATIONS
660		Stop Vehicle Press RESET. Finish mission. Notify maintenance.	Warning - Degraded Operation Logical error at output speed input, transmission ECU measures internal speed over a threshold and at the next moment the measured speed is zero Cables defective. Sensor defective.	Gearshift quality is reduced due to another control mode. (Operating mode: substitute clutch control). If there is also a failure at turbine speed, transmission ECU shifts to neutral. Limp home.
662		Stop Vehicle Press RESET. Finish mission. Notify maintenance.	Warning - Degraded Operation Output speed does not fit other speed signals. If transmission is not in neutral and shifting has finished, transmission ECU measures output speed as zero and turbine or internal speed as not equal to zero Cables defective. Sensor defective. Incorrect sensor gap size.	Gearshift quality is reduced due to another control mode. (Operating mode: substitute clutch control). If there is also a failure at turbine speed, transmission ECU shifts to neutral. Limp home.
684		Finish Mission Shut engine OFF/ON. If code clears, resume mission. If code remains, notify maintenance.	Warning - Degraded Operation Time-out of CAN message from display computer Cable defective. Defective display computer.	Error codes from transmission ECU will not show.
685		Finish Mission Shut engine OFF/ON. If code clears, resume mission. If code remains, notify maintenance.	Warning - Degraded Operation Time-out of CAN message from display computer Cable defective. Defective steering computer.	Error codes from transmission ECU will not show.

Table 1. Error Codes - Continued.

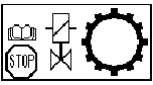
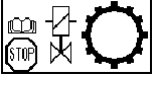

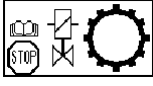
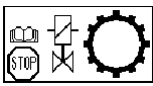
ERROR CODE	DISPLAY LAYOUT	DRIVER ACTION	ERROR CODE CATEGORY/ EXPLANATION	VEHICLE LIMITATIONS
713		Stop Vehicle Abort mission. Notify maintenance.	Stop Vehicle Immediately Short circuit to battery voltage at clutch K1, measured resistance value of valve is out of limit, voltage at K1 valve is too high Cables defective. Regulator defective.	Transmission ECU shifts to neutral. Limp home. If there is also a failure at another clutch, ECU shifts to neutral. ECU will shut down.
714		Stop Vehicle Abort mission. Notify maintenance.	Stop Vehicle Immediately Short circuit to ground at clutch K1, measured resistance value of valve is out of limit, voltage at K1 valve is too low Cables defective. Regulator defective.	Transmission ECU shifts to neutral. Limp home. If there is also a failure at another clutch, ECU shifts to neutral. ECU will shut down.
715		Stop Vehicle Abort mission. Notify maintenance.	Stop Vehicle Immediately Open circuit at clutch K1, measured resistance value of valve is out of limit Cables defective. Regulator defective.	Transmission ECU shifts to neutral. Limp home. If there is also a failure at another clutch, ECU shifts to neutral. ECU will shut down.
716		Stop Vehicle Abort mission. Notify maintenance.	Stop Vehicle Immediately Short circuit to battery voltage at clutch K2, measured resistance value of valve is out of limit, voltage at K2 valve is too high Cables defective. Regulator defective.	Transmission ECU shifts to neutral. Limp home. If there is also a failure at another clutch, ECU shifts to neutral. ECU will shut down.
717		Stop Vehicle Abort mission. Notify maintenance.	Stop Vehicle Immediately Short circuit to ground at clutch K2, measured resistance value of valve is out of limit, voltage at K2 valve is too low Cables defective. Regulator defective.	Transmission ECU shifts to neutral. Limp home. If there is also a failure at another clutch, ECU shifts to neutral. ECU will shut down.

Table 1. Error Codes - Continued.

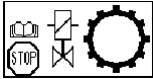
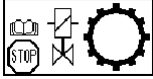

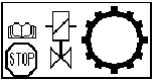

ERROR CODE	DISPLAY LAYOUT	DRIVER ACTION	ERROR CODE EXPLANATION	VEHICLE LIMITATIONS
718		Stop Vehicle Abort mission. Notify maintenance.	Stop Vehicle Immediately Open circuit at clutch K2, measured resistance value of valve is out of limit Cables defective. Regulator defective.	Transmission ECU shifts to neutral. Limp home. If there is also a failure at another clutch, ECU shifts to neutral. ECU will shut down.
719		Stop Vehicle Abort mission. Notify maintenance.	Stop Vehicle Immediately Short circuit to battery voltage at clutch K3, measured resistance value of valve is out of limit, voltage at K3 valve is too high Cables defective. Regulator defective.	Transmission ECU shifts to neutral. Limp home. If there is also a failure at another clutch, ECU shifts to neutral. ECU will shut down.
720		Stop Vehicle Abort mission. Notify maintenance.	Stop Vehicle Immediately Short circuit to ground at clutch K3, measured resistance value of valve is out of limit, voltage at K3 valve is too low Cables defective. Regulator defective.	Transmission ECU shifts to neutral. Limp home. If there is also a failure at another clutch, ECU shifts to neutral. ECU will shut down.
721		Stop Vehicle Abort mission. Notify maintenance.	Stop Vehicle Immediately Open circuit at clutch K3, measured resistance value of valve is out of limit Cables defective. Regulator defective.	Transmission ECU shifts to neutral. Limp home. If there is also a failure at another clutch, ECU shifts to neutral. ECU will shut down.
729		Stop Vehicle Abort mission. Notify maintenance.	Stop Vehicle Immediately Short circuit to battery voltage at clutch K4, measured resistance value of valve is out of limit, voltage at K4 valve is too high Cables defective. Regulator defective.	Transmission ECU shifts to neutral. Limp home. If there is also a failure at another clutch, ECU shifts to neutral. ECU will shut down.

Table 1. Error Codes - Continued.

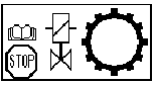
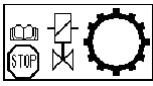
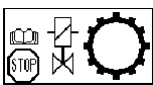
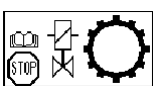

ERROR CODE	DISPLAY LAYOUT	DRIVER ACTION	ERROR CODE EXPLANATION	VEHICLE LIMITATIONS
730		Stop Vehicle Abort mission. Notify maintenance.	Stop Vehicle Immediately Short circuit to ground at clutch K4, measured resistance value of valve is out of limit, voltage at K4 valve is too low Cables defective. Regulator defective.	Transmission ECU shifts to neutral. Limp home. If there is also a failure at another clutch, ECU shifts to neutral. ECU will shut down.
731		Stop Vehicle Abort mission. Notify maintenance.	Stop Vehicle Immediately Open circuit at clutch K4, measured resistance value of valve is out of limit Cables defective. Regulator defective.	Transmission ECU shifts to neutral. Limp home. If there is also a failure at another clutch, ECU shifts to neutral. ECU will shut down.
732		Stop Vehicle Abort mission. Notify maintenance.	Stop Vehicle Immediately Short circuit to battery voltage at clutch KV, measured resistance value of valve is out of limit, voltage at KV valve is too high Cables defective. Regulator defective.	Transmission ECU shifts to neutral. Limp home. If there is also a failure at another clutch, ECU shifts to neutral. ECU will shut down.
733		Stop Vehicle Abort mission. Notify maintenance.	Stop Vehicle Immediately Short circuit to ground at clutch KV, measured resistance value of valve is out of limit, voltage at KV valve is too low Cables defective. Regulator defective.	Transmission ECU shifts to neutral. Limp home. If there is also a failure at another clutch, ECU shifts to neutral. ECU will shut down.
734		Stop Vehicle Abort mission. Notify maintenance.	Stop Vehicle Immediately Open circuit at clutch KV, measured resistance value of the valve is out of limit Cables defective. Regulator defective.	Transmission ECU shifts to neutral. Limp home. If there is also a failure at another clutch, ECU shifts to neutral. ECU will shut down.

Table 1. Error Codes - Continued.

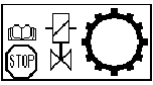
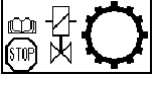

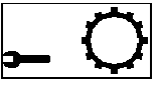
ERROR CODE	DISPLAY LAYOUT	DRIVER ACTION	ERROR CODE EXPLANATION	VEHICLE LIMITATIONS
735		Stop Vehicle Abort mission. Notify maintenance.	Stop Vehicle Immediately Short circuit to battery voltage at clutch KR, measured resistance value of valve is out of limit, voltage at KR valve is too high Cables defective. Regulator defective.	Transmission ECU shifts to neutral. Limp home. If there is also a failure at another clutch, ECU shifts to neutral. ECU will shut down.
736		Stop Vehicle Abort mission. Notify maintenance.	Stop Vehicle Immediately Short circuit to ground at clutch KR, measured resistance value of valve is out of limit, voltage at KR valve is too low Cables defective. Regulator defective.	Transmission ECU shifts to neutral. Limp home. If there is also a failure at another clutch, ECU shifts to neutral. ECU will shut down.
737		Stop Vehicle Abort mission. Notify maintenance.	Stop Vehicle Immediately Open circuit at clutch KR, measured resistance value of valve is out of limit Cables defective. Regulator defective.	Transmission ECU shifts to neutral. Limp home. If there is also a failure at another clutch, ECU shifts to neutral. ECU will shut down.
745		Finish Mission Notify maintenance.	Information/Maintenance Short circuit to ground at relay reverse warning alarm, transmission ECU detected a wrong voltage at output pin that looks like a short circuit to battery voltage Cables defective. Backup alarm device defective.	None.

Table 1. Error Codes - Continued.



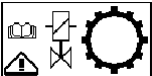

ERROR CODE	DISPLAY LAYOUT	DRIVER ACTION	ERROR CODE EXPLANATION	VEHICLE LIMITATIONS
746		Finish Mission Notify maintenance.	Information/Maintenance Short circuit to battery voltage at relay reverse warning alarm, transmission ECU detected a wrong voltage at output pin that looks like a short circuit to battery voltage Cables defective. Backup alarm device defective.	None.
747		Finish Mission Notify maintenance.	Information/Maintenance Open circuit at relay reverse warning alarm, transmission ECU detected a wrong voltage at output pin that looks like an open circuit for this output pin Cables defective. Backup alarm device defective.	None.
761		Stop Vehicle Press RESET. Finish mission. Notify maintenance.	Warning - Degraded Operation Short circuit to ground at axle connection solenoid, transmission ECU detected a wrong voltage at output pin that looks like a short circuit to vehicle ground Cables defective. Axle connection solenoid defective.	Switching from 2WD to 4WD is impossible.
762		Stop Vehicle Press RESET. Finish mission. Notify maintenance.	Warning - Degraded Operation Short circuit to battery voltage axle connection solenoid, transmission ECU detected a wrong voltage at output pin that looks like a short circuit to battery voltage Cables defective. Axle connection solenoid defective.	Switching from 2WD to 4WD is impossible.

Table 1. Error Codes - Continued.

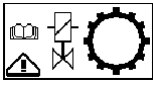
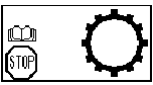

ERROR CODE	DISPLAY LAYOUT	DRIVER ACTION	ERROR CODE EXPLANATION	VEHICLE LIMITATIONS
763		Stop Vehicle Press RESET. Finish mission. Notify maintenance.	Warning - Degraded Operation Open circuit at axle connection solenoid, transmission ECU detected a wrong voltage at output pin that looks like an open circuit for this output pin Cables defective. Axle connection solenoid defective.	Switching from 2WD to 4WD is impossible.
777		Stop Vehicle Abort mission. Notify maintenance.	Stop Vehicle Immediately Slippage at clutch K1, transmission ECU calculates a differential speed at closed clutch K1. If this calculated value is outside of range, ECU interprets this as a slipping clutch Low pressure. Sensor defective. Incorrect sensor gap size. Clutch defective.	Transmission ECU shifts to neutral. Limp home. If there is also a failure at another clutch, ECU shifts to neutral. ECU will shut down.
778		Stop Vehicle Abort mission. Notify maintenance.	Stop Vehicle Immediately Slippage at clutch K2, transmission ECU calculates a differential speed at closed clutch K2. If this calculated value is outside of range, ECU interprets this as a slipping clutch Low pressure. Sensor defective. Incorrect sensor gap size. Clutch defective.	Transmission ECU shifts to neutral. Limp home. If there is also a failure at another clutch, ECU shifts to neutral. ECU will shut down.

Table 1. Error Codes - Continued.




ERROR CODE	DISPLAY LAYOUT	DRIVER ACTION	ERROR CODE EXPLANATION	VEHICLE LIMITATIONS
779		<p>Stop Vehicle Abort mission. Notify maintenance.</p>	<p>Stop Vehicle Immediately</p> <p>Slippage at clutch K3, transmission ECU calculates a differential speed at closed clutch K3. If this calculated value is outside of range, ECU interprets this as a slipping clutch</p> <p>Low pressure. Sensor defective. Incorrect sensor gap size. Clutch defective.</p>	<p>ECU shifts to neutral. Limp home. If there is also a failure at another clutch, ECU shifts to neutral. ECU will shut down.</p>
780		<p>Stop Vehicle Abort mission. Notify maintenance.</p>	<p>Stop Vehicle Immediately</p> <p>Slippage at clutch K4, transmission ECU calculates a differential speed at closed clutch K4. If this calculated value is outside of range, ECU interprets this as a slipping clutch</p> <p>Low pressure. Sensor defective. Incorrect sensor gap size. Clutch defective.</p>	<p>Transmission ECU shifts to neutral. Limp home. If there is also a failure at another clutch, ECU shifts to neutral. ECU will shut down.</p>
781		<p>Stop Vehicle Abort mission. Notify maintenance.</p>	<p>Stop Vehicle Immediately</p> <p>Slippage at clutch KV, transmission ECU calculates a differential speed at closed clutch KV. If this calculated value is outside of range, ECU interprets this as a slipping clutch</p> <p>Low pressure. Sensor defective. Incorrect sensor gap size. Clutch defective.</p>	<p>Transmission ECU shifts to neutral. Limp home. If there is also a failure at another clutch, ECU shifts to neutral. ECU will shut down.</p>

Table 1. Error Codes - Continued.





ERROR CODE	DISPLAY LAYOUT	DRIVER ACTION	ERROR CODE EXPLANATION	VEHICLE LIMITATIONS
782		Stop Vehicle Abort mission. Notify maintenance.	Stop Vehicle Immediately Slippage at clutch KR, transmission ECU calculates a differential speed at closed clutch KR. If this calculated value is outside of range, ECU interprets this as a slipping clutch Low pressure. Sensor defective. Incorrect sensor gap size. Clutch defective.	Transmission ECU shifts to neutral. Limp home. If there is also a failure at another clutch, ECU shifts to neutral. ECU will shut down.
783		Stop Vehicle Check oil level. Allow transmission to cool down. Press RESET. If error shows again, notify maintenance. Finish mission.	Warning - Degraded Operation Overheated sump, transmission ECU measured temperature in oil sump that is over 212°F (100°C) Low oil level. Temperature sensor defective.	None.
786		Finish Mission Notify maintenance.	Information/Maintenance Oil filter differential pressure, transmission ECU measured a voltage at differential pressure switch out of allowable range Oil filter polluted. Cable/connector defective. Differential switch defective.	None.
795		Stop Vehicle Check oil level. Allow transmission to cool down. Press RESET. If error shows again, notify maintenance. Finish mission.	Warning - Degraded Operation Overheated converter output, ECU measured oil temperature at converter output that is over 248°F (120°C) Low oil level. Temperature sensor defective.	None.

Table 1. Error Codes - Continued.

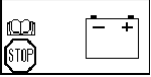
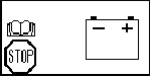
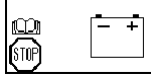
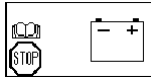
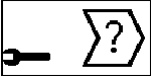

ERROR CODE	DISPLAY LAYOUT	DRIVER ACTION	ERROR CODE EXPLANATION	VEHICLE LIMITATIONS
811		Stop Vehicle Abort mission. Notify maintenance.	Stop Vehicle Immediately Low power at battery, measured voltage at power supply is lower than 18V Cable defective. Battery defective. Connector defective.	Transmission ECU shifts to neutral. ECU will shut down.
812		Stop Vehicle Abort mission. Notify maintenance.	Stop Vehicle Immediately High power at battery, measured voltage at power supply is higher than 32.5V Cable defective. Battery defective. Connector defective.	Transmission ECU shifts to neutral. ECU will shut down.
813		Stop Vehicle Abort mission. Notify maintenance.	Stop Vehicle Immediately Error at shift valve power supply (VPS1) Cable defective. Battery defective. Connector defective.	ECU shifts to neutral. ECU will shut down.
814		Stop Vehicle Abort mission. Notify maintenance.	Stop Vehicle Immediately Error at shift valve power supply (VPS2) Cable defective. Connector defective. ECU defective.	ECU shifts to neutral. ECU will shut down.
841		Finish Mission Notify maintenance.	Information/Maintenance General EEPROM fault, ECU cannot read memory ECU defective.	None.
843		Stop Vehicle Abort mission. Notify maintenance.	Stop Vehicle Immediately Application error ECU defective.	Transmission stays in neutral. ECU will shut down.

Table 1. Error Codes - Continued.

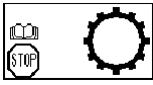
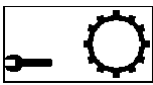
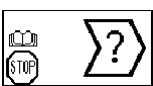
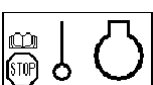
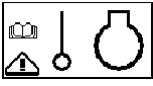
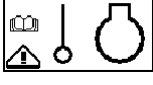
ERROR CODE	DISPLAY LAYOUT	DRIVER ACTION	ERROR CODE EXPLANATION	VEHICLE LIMITATIONS
845		Stop Vehicle Abort mission. Notify maintenance.	Stop Vehicle Immediately Clutch failure, AEB was not able to adjust clutch filling parameters Clutch defective.	Transmission stays in neutral. ECU will shut down.
846		Finish Mission Notify maintenance.	Information/Maintenance Clutch adjustment data lost, ECU was not able to read correct adjustment parameters Interference during data saving process.	None.
1111		Engine Will Not Start - Notify Maintenance	Stop Vehicle Immediately ECM internal internal memory error Hardware defective. Internal microprocessor communication failure.	Engine will not start.
1115		Stop Vehicle Shut engine off for 30 seconds, then turn engine ON. If code clears, resume mission, then notify maintenance. If code remains, notify maintenance.	Stop Vehicle Immediately No engine speed signal detected at both engine position sensor circuits	Engine will shut down and will not start.
1121		Stop Vehicle Press RESET. If error shows again, notify maintenance. Finish mission.	Warning - Degraded Operation No engine speed signal detected at one engine position sensor circuit	None.
1122		Stop Vehicle Press RESET. If error shows again, notify maintenance. Finish mission.	Warning - Degraded Operation High voltage detected at intake manifold pressure sensor circuit	Reduced engine power output.

Table 1. Error Codes - Continued.

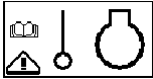
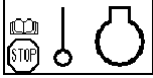

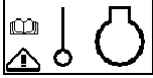
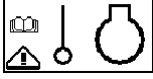

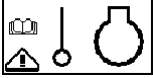
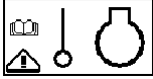
ERROR CODE	DISPLAY LAYOUT	DRIVER ACTION	ERROR CODE EXPLANATION	VEHICLE LIMITATIONS
1123		Stop Vehicle Press RESET. If error shows again, notify maintenance. Finish mission.	Warning - Degraded Operation Low voltage detected at intake manifold pressure sensor circuit	Reduced engine power output.
1131		Stop Vehicle Abort mission. Notify maintenance.	Stop Vehicle Immediately High voltage detected at throttle position sensor circuit	Severe power and speed loss. Limp home power only.
1132		Stop Vehicle Abort mission. Notify maintenance.	Stop Vehicle Immediately Low voltage detected at throttle position sensor circuit	Severe power and speed loss. Limp home power only.
1135		Stop Vehicle Press RESET. If error shows again, notify maintenance. Finish mission.	Warning - Degraded Operation High voltage detected at oil pres- sure sensor circuit	Oil pressure warning not working.
1141		Stop Vehicle Press RESET. If error shows again, notify maintenance. Finish mission.	Warning - Degraded Operation Low voltage detected at oil pres- sure sensor circuit	Oil pressure warning not working.
1143		Stop Vehicle Check oil level. Press RESET. If error shows again, notify maintenance. Finish mission.	Warning - Degraded Operation Oil pressure signal indicates low oil pressure	Reduced power and speed.
1144		Stop Vehicle Press RESET. If error shows again, notify maintenance. Finish mission.	Warning - Degraded Operation High voltage detected at coolant temperature circuit	Temperature warning not functioning.
1145		Stop Vehicle Press RESET. If error shows again, notify maintenance. Finish mission.	Warning - Degraded Operation Low voltage detected at coolant temperature circuit	Temperature warning not functioning.

Table 1. Error Codes - Continued.





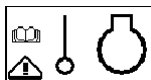
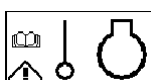
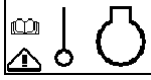
ERROR CODE	DISPLAY LAYOUT	DRIVER ACTION	ERROR CODE EXPLANATION	VEHICLE LIMITATIONS
1151		Stop Vehicle Check coolant level. If error remains, notify maintenance.	Stop Vehicle Immediately Coolant temperature signal indicated coolant temperature above critical threshold	Reduced power and speed.
1153		Stop Vehicle Press RESET. If error remains, notify maintenance.	Warning - Degraded Operation High voltage detected at intake manifold temperature sensor circuit	Possible white smoke. No engine protection for intake manifold temperature.
1154		Stop Vehicle Press RESET. If error shows again, notify maintenance. Finish mission.	Warning - Degraded Operation Low voltage detected at intake manifold temperature sensor circuit	Possible white smoke. No engine protection for intake manifold temperature.
1155		Stop Vehicle Check coolant level. If error remains, notify maintenance.	Stop Vehicle Immediately Intake manifold temperature signal indicated coolant temperature above critical threshold	Reduced power and speed.
1187		Stop Vehicle Press RESET. Finish mission. Notify maintenance.	Warning - Degraded Operation Low voltage detected on ECM voltage supply line to some sensors	Engine will run degraded. No protection for oil pressure.
1212		Stop Vehicle Press RESET. If error shows again, notify maintenance. Finish mission.	Warning - Degraded Operation High voltage detected at oil temperature sensor circuit	No engine protection for oil temperature.
1213		Stop Vehicle Press RESET. If error shows again, notify maintenance. Finish mission.	Warning - Degraded Operation Low voltage detected at oil temperature sensor circuit	No engine protection for oil temperature.

Table 1. Error Codes - Continued.



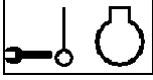
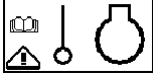



ERROR CODE	DISPLAY LAYOUT	DRIVER ACTION	ERROR CODE EXPLANATION	VEHICLE LIMITATIONS
1214		Stop Vehicle Check oil level. Press RESET. If error remains, notify maintenance. Finish mission.	Stop Vehicle Immediately Oil pressure signal indicates temperature above critical threshold	Reduced power and speed.
1221		Finish Mission Notify maintenance.	Information/Maintenance High voltage detected at ambient air pressure sensor circuit	Reduced power and speed.
1222		Finish Mission Notify maintenance.	Information/Maintenance Low voltage detected at ambient air pressure sensor circuit	Reduced power and speed.
1227		Stop Vehicle Press RESET. Finish mission. Notify maintenance.	Warning - Degraded Operation High voltage detected on ECM voltage supply line to some sensors	Engine will run degraded. No protection for oil pressure.
1234		Stop Vehicle Shut engine OFF/ON. If code clears, resume mission. If code remains, notify maintenance.	Stop Vehicle Immediately Engine speed signal indicates engine speed greater than 2,730 RPM	Fuel shutoff valve is closed until engine speed drops. Fuel shutoff valve will open when engine speed falls below 2,184 RPM.
1254		Stop Vehicle Shut engine OFF/ON. If code clears, resume mission. If code remains, notify maintenance.	Stop Vehicle Immediately Less than 6V detected at fuel shutoff driver Excessive current draw. Power supply faulty.	ECM turns off FSO supply voltage. Engine will shut down.
1255		Stop Vehicle Press RESET. Finish mission. Notify maintenance.	Warning - Degraded Operation Externally supplied voltage detected going to fuel shutoff supply circuit	No performance limitations. Fuel shutoff valve stays open.

Table 1. Error Codes - Continued.






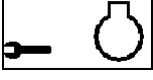
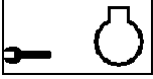

ERROR CODE	DISPLAY LAYOUT	DRIVER ACTION	ERROR CODE EXPLANATION	VEHICLE LIMITATIONS
1285		Stop Vehicle Shut engine OFF/ON. If code clears, resume mission. If code remains, notify maintenance.	Warning - Degraded Operation Information from multiplexed device not received by ECM or received too late	At least one multiplexed device will not operate properly.
1286		Stop Vehicle Shut engine OFF/ON. If code clears, resume mission. If code remains, notify maintenance.	Warning - Degraded Operation Only a portion of information from multiplexed device received by ECM	At least one multiplexed device will not operate properly.
1287		Stop Vehicle Shut engine OFF/ON. If code clears, resume mission. If code remains, notify maintenance.	Stop Vehicle Immediately Data error received while multiplexing throttle pedal and IVS	The engine will only idle.
1295		Finish Mission Notify maintenance.	Information/Maintenance Ambient air pressure sensor circuit error detected by ECM	Engine is degraded to no air setting.
1298		Finish Mission Notify maintenance.	Information/Maintenance Air intake filter clogged	Engine is degraded to no air setting.
1311		Finish Mission Notify maintenance.	Information/Maintenance Current detected at injector for cylinder #1 when voltage is turned OFF	Injector for cylinder #1 turned off.
1312		Finish Mission Notify maintenance.	Information/Maintenance Current detected at injector for cylinder #5 when voltage is turned OFF	Injector for cylinder #5 turned off.
1313		Finish Mission Notify maintenance.	Information/Maintenance Current detected at injector for cylinder #3 when voltage is turned OFF	Injector for cylinder #3 turned off.

Table 1. Error Codes - Continued.


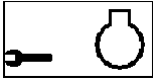
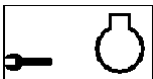
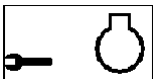
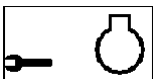
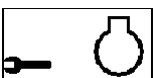
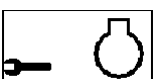
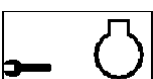
ERROR CODE	DISPLAY LAYOUT	DRIVER ACTION	ERROR CODE EXPLANATION	VEHICLE LIMITATIONS
1314		Finish Mission Notify maintenance.	Information/Maintenance Current detected at injector for cylinder #6 when voltage is turned OFF	Injector for cylinder #6 turned off.
1315		Finish Mission Notify maintenance.	Information/Maintenance Current detected at injector for cylinder #2 when voltage is turned OFF	Injector for cylinder #2 turned off.
1321		Finish Mission Notify maintenance.	Information/Maintenance Current detected at injector for cylinder #4 when voltage is turned OFF	Injector for cylinder #4 turned off.
1322		Finish Mission Notify maintenance.	Information/Maintenance No current detected at injector for cylinder #1 when voltage is turned ON	Injector for cylinder #1 turned off.
1323		Finish Mission Notify maintenance.	Information/Maintenance No current detected at injector for cylinder #5 when voltage is turned ON	Injector for cylinder #5 turned off.
1324		Finish Mission Notify maintenance.	Information/Maintenance No current detected at injector for cylinder #3 when voltage is turned ON	Injector for cylinder #3 turned off.
1325		Finish Mission Notify maintenance.	Information/Maintenance No current detected at injector for cylinder #6 when the voltage is turned ON	Injector for cylinder #6 turned off.
1331		Finish Mission Notify maintenance.	Information/Maintenance No current detected at injector for cylinder #2 when voltage is turned ON	Injector for cylinder #2 turned off.

Table 1. Error Codes - Continued.


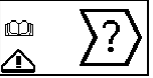
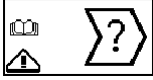
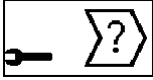


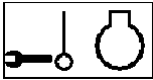
ERROR CODE	DISPLAY LAYOUT	DRIVER ACTION	ERROR CODE EXPLANATION	VEHICLE LIMITATIONS
1332		Finish Mission Notify maintenance.	Information/Maintenance No current detected at injector for cylinder #4 when voltage is turned ON	Injector for cylinder #4 turned off.
1341		Stop Vehicle Shut engine OFF/ON. If code clears, resume mission. If code remains, notify maintenance.	Warning - Degraded Operation Severe loss of data from ECM	No noticeable performance effects possible. Possibility of engine stopping or difficulty in starting engine.
1343		Stop Vehicle Shut engine OFF/ON. If code clears, resume mission. If code remains, notify maintenance.	Warning - Degraded Operation Microprocessor communication error inside ECM	No noticeable performance effects possible. May encounter severe loss of power.
1346		Finish Mission Notify maintenance.	Information/Maintenance Software error in ECM	Possibly too short of time for ECM to power down, less than 30 seconds.
1352		Stop Vehicle Press RESET. Finish mission. Notify maintenance.	Warning - Degraded Operation Low voltage detected at sensor Faulty power supply.	Engine is degraded to no air setting.
1415		Stop Vehicle Check oil level. Press RESET. If error remains, notify maintenance. Finish mission.	Stop Vehicle Immediately Oil pressure signal indicates below critical threshold	Reduced power and speed.
1419		Finish Mission Notify maintenance.	Information/Maintenance Error in intake manifold pressure sensor signal detected by ECM	Engine is degraded to no air setting.

Table 1. Error Codes - Continued.

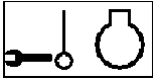

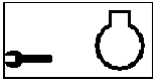

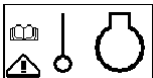
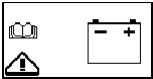
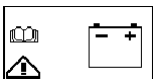
ERROR CODE	DISPLAY LAYOUT	DRIVER ACTION	ERROR CODE EXPLANATION	VEHICLE LIMITATIONS
1431		Finish mission Notify maintenance.	Information/Maintenance Both idle validation off-idle and on-idle signals indicate the same voltage reading	None.
1432		Stop Vehicle Press RESET. Finish mission. Notify maintenance.	Warning - Degraded Operation Idle validation switch voltages are opposite (complimentary) but disagree with a valid throttle position sensor	Engine will only idle.
1433		Finish Mission Notify maintenance.	Information/Maintenance Intake manifold pressure sensor voltage indicates a high pressure reading	Engine is degraded to no air setting.
1434		Stop Vehicle Press RESET. Finish mission. Notify maintenance.	Warning - Degraded Operation Battery voltage too low or insufficient amount of time for battery power to ECM for powering down after key off	No noticeable performance effects possible. Possibility of engine stopping or difficulty in starting engine.
1435		Stop Vehicle Press RESET. Finish mission. Notify maintenance.	Warning - Degraded Operation ECM detects error in oil pressure sensor signal sensor	None. No engine protection for oil pressure.
1441		Stop Vehicle Press RESET. Finish mission. Notify maintenance.	Warning - Degraded Operation Battery voltage below normal operating level	No noticeable performance effects possible. Possibility of rough idle.
1442		Stop Vehicle Press RESET. Finish mission. Notify maintenance.	Warning - Degraded Operation Battery voltage above normal operating level	None.

Table 1. Error Codes - Continued.


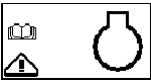

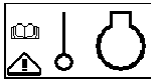
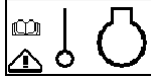
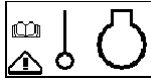
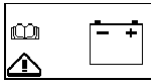
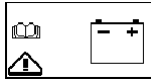
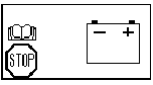

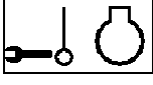
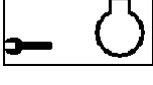

ERROR CODE	DISPLAY LAYOUT	DRIVER ACTION	ERROR CODE EXPLANATION	VEHICLE LIMITATIONS
1443		Stop Vehicle Press RESET. Finish mission. Notify maintenance.	Warning - Degraded Operation Low voltage detected on ECM voltage supply line to throttle	Engine will only idle.
1474		Stop Vehicle Press RESET. Finish mission. Notify maintenance.	Warning - Degraded Operation Low voltage detected on starter lockout relay circuit when energized or voltage detected when circuit de-energized	None.
1551 IVS		Stop Vehicle Press RESET. Finish mission. Notify maintenance.	Warning - Degraded Operation No voltage detected simultaneously on both idle validation off-idle and on-idle circuits	Engine will only idle.
1581		Stop Vehicle Press RESET. Finish mission. Notify maintenance.	Warning - Degraded Operation High voltage detected at fuel inlet pressure sensor circuit	None.
1582		Stop Vehicle Press RESET. Finish mission. Notify maintenance.	Warning - Degraded Operation Low voltage detected at fuel inlet pressure sensor circuit	None.
1583		Stop Vehicle Press RESET. Finish mission. Notify maintenance.	Warning - Degraded Operation Out-of-range low voltage detected at fuel inlet pressure sensor circuit	None.
1596		Stop Vehicle Press RESET. Finish mission. Notify maintenance.	Warning - Degraded Operation Battery voltage above normal operating range	None.
1597		Stop Vehicle Press RESET. Finish mission. Notify maintenance.	Warning - Degraded Operation Battery voltage below normal operating range	None.

Table 1. Error Codes - Continued.

ERROR CODE	DISPLAY LAYOUT	DRIVER ACTION	ERROR CODE EXPLANATION	VEHICLE LIMITATIONS
1598		Stop Vehicle Abort mission. Notify maintenance.	Stop Vehicle Immediately Very low battery voltage, critical level	None.
1697		Finish Mission Notify maintenance.	Information/Maintenance High voltage detected at ECM internal temperature sensor circuit	None.
1698		Finish Mission Notify maintenance.	Information/Maintenance Low voltage detected at ECM internal temperature sensor circuit	None.
1951		Finish Mission Notify maintenance.	Information/Maintenance Power imbalance between cylinders detected by ECM	Engine may rough idle or misfire.
1999		Stop Vehicle Press RESET. Check all errors that show. Notify maintenance.	Stop Vehicle Immediately More than 6 errors active on the J1939 bus to the display	None.

END OF WORK PACKAGE

ERROR CODE SYMPTOM INDEX

Malfunction/Symptom **Troubleshooting Procedure Page**

AUXILIARY PUMP

Error Code 169 - Tophandler Emergency Function Supply Valve, Open or Short Circuit Failure. 0037 00-1
 Error Code 411 - Auxiliary Pump Control, Short Circuit Failure. 0037 00-3
 Error Code 417 - Auxiliary Pump Switch, Circuit Input Error. 0037 00-4

AXLE BRAKE COOLING SYSTEM

Error Code 191 - Temperature in Front Axle Above Critical Threshold. 0032 00-1
 Error Code 192 - Temperature in Rear Axle Above Critical Threshold. 0032 00-4
 Error Code 414 - Brake Cooling Bypass Valve, Short Circuit Failure. 0032 00-6

BOOM IN/OUT

Error Code 127 - Joystick-to-ECU (790) Failure. 0041 00-1
 Error Code 130 - Overload Protection System Failure. 0041 00-2
 Error Code 160 - Extension Cylinder Boom IN Control, Wiring Circuit Failure. 0041 00-3
 Error Code 161 - Extension Cylinder Boom IN Control, Component Failure. 0041 00-4
 Error Code 163 - Extension Cylinder Boom OUT Control Valve, Wiring Circuit Failure. 0041 00-5
 Error Code 164 - Extension Cylinder Boom OUT Control Valve, Component Failure. 0041 00-6

BOOM LIFTING/LOWERING

Error Code 126 - Joystick-to-ECU (790) Failure. 0040 00-1
 Error Code 130 - Overload Protection System Failure. 0040 00-2
 Error Code 151 - Lift Cylinder Locking Valve, Wiring Circuit Failure. 0040 00-3
 Error Code 152 - Lift Cylinder Locking Valve, Component Failure. 0040 00-4
 Error Code 154 - Lift Cylinder Boom Up Valve, Wiring Circuit Failure. 0040 00-5
 Error Code 155 - Lift Cylinder Boom Up Valve, Component Failure. 0040 00-6
 Error Code 157 - Lift Cylinder Boom Down Valve, Wiring Circuit Failure. 0040 00-7
 Error Code 158 - Lift Cylinder Boom Down Valve, Component Failure. 0040 00-8

BRAKE SYSTEM

Error Code 118 - Brake System Pressure, Circuit 1 and Circuit 2 Failure. 0031 00-1
 Error Code 119 - Brake System Pressure, Circuit 1 Failure. 0031 00-3
 Error Code 120 - Brake System Pressure, Circuit 2 Failure. 0031 00-4

COOLING FAN OPERATION AND FAN CONTROL

Error Code 166 - Cooling Fan Speed, Wiring Circuit Failure. 0010 00-1
 Error Code 167 - Cooling Fan Speed, Short Circuit Failure. 0010 00-3
 Error Code 426 - Fording Level Switch, Circuit Input Error. 0010 00-4

ECU-TO-ECU COMMUNICATIONS

Error Code 103 - ECU (790) Not Responding (RESET or USMC Only). 0014 00-2
 Error Code 105 - ECU (790) Not Responding. 0014 00-2
 Error Code 106 - ECU (791) Not Responding. 0014 00-3
 Error Code 107 - Cable Failure Between Tophandler ECU (791) and Display ECU (795). 0014 00-5
 Error Code 108 - Cable Failure Between Tophandler ECU (791) and Servo ECU (790). 0014 00-6
 Error Code 109 - Cable Failure Between Servo ECU (790) and Display ECU (795). 0014 00-7

ERROR CODE SYMPTOM INDEX - CONTINUED

Malfunction/Symptom **Troubleshooting Procedure Page**

ECU-TO-ECU COMMUNICATIONS - CONTINUED

Error Code 110 - Communication Failure Between Display ECU (795) and Steering ECU (792)... 0014 00-8
 Error Code 111 - Communication Failure Between Display ECU (795) and Transmission ECU (793)... 0014 00-9
 Error Code 112 - Communication Failure Between Display ECU (795) and Engine ECU (794)... 0014 00-10
 Error Code 345 - Communication Failure Between Steering ECU (792) and Display ECU (795)... 0014 00-12
 Error Code 346 - Communication Failure Between Steering ECU (792) and Transmission ECU (793)... 0014 00-12
 Error Code 684 - Communication Failure Between Transmission ECU (793) and Display ECU (795)... 0014 00-13
 Error Code 685 - Communication Failure Between Transmission ECU (793) and Steering ECU (792)... 0014 00-13
 Error Code 1285 - Engine Detects a Communication Failure on the J1939 Datalink... 0014 00-14
 Error Code 1286 - Engine Detects a Communication Failure on the J1939 Datalink... 0014 00-14

ELECTRONIC CONTROL UNIT (ECU) SUPPLY VOLTAGE

Error Code 451 - Voltage Supply Too High for Steering ECU (792)... 0016 00-1
 Error Code 452 - Voltage Supply Too Low for Steering ECU (792)... 0016 00-2
 Error Code 453 - Wheel Sensor Supply Voltage Out of Range (RESET or USMC Only)... 0016 00-3
 Error Code 454 - Wheel Sensor Supply Voltage Out of Range (RESET or USMC Only)... 0016 00-5
 Error Code 811 - Voltage Supply Too Low for Transmission ECU (793)... 0016 00-7
 Error Code 812 - Voltage Supply Too High for Transmission ECU (793)... 0016 00-8
 Error Code 813 - Voltage Failure at Transmission Gearshift Valve Supply... 0016 00-8
 Error Code 814 - Voltage Failure at Transmission Gearshift Valve Power Supply... 0016 00-9

ELECTRONIC CONTROL UNIT (ECU) INPUT VOLTAGE

Error Code 121 - Supply Voltage to Servo ECU (790) Failure... 0013 00-1
 Error Code 122 - Supply Voltage to Servo ECU (790) Failure... 0013 00-3
 Error Code 123 - 10V Reference Voltage for Servo ECU (790) Short Circuit Failure... 0013 00-4
 Error Code 201 - Supply Voltage to Tophandler ECU (791) Failure... 0013 00-6
 Error Code 202 - Supply Voltage to Tophandler ECU (791) Failure... 0013 00-9
 Error Code 203 - 10V Reference Voltage for Tophandler ECU (791) Failure... 0013 00-10

ENGINE AMBIENT AIR PRESSURE SENSOR AND CIRCUITS

Error Code 1221 - High Voltage Detected at Ambient Air Pressure Sensor Circuit... 0022 00-1
 Error Code 1222 - Low Voltage Detected at Ambient Air Pressure Sensor Circuit... 0022 00-6
 Error Code 1295 - Ambient Air Pressure Sensor Circuit Failure... 0022 00-13
 Error Code 1298 - High Intake Air Restriction or Circuit Failure (RESET or USMC Only)... 0022 00-13

ENGINE BATTERY VOLTAGE CIRCUITS

Error Code 1434 - Unswitched Battery Supply Circuit Failure... 0025 00-1
 Error Code 1441 - Unswitched Battery Supply Circuit Failure... 0025 00-4
 Error Code 1442 - Unswitched Battery Supply Circuit Failure... 0025 00-4
 Error Code 1474 - Starter Solenoid Lockout Relay Driver Circuit Failure... 0025 00-5
 Error Code 1596 - Voltage Monitor, High Voltage Failure... 0025 00-8

ERROR CODE SYMPTOM INDEX - CONTINUED

Malfunction/Symptom **Troubleshooting Procedure Page**

ENGINE FUEL INJECTOR CIRCUITS

Error Code 1311 - Injector Circuit Failure.....	0008 00-1
Error Code 1312 - Injector Circuit Failure.....	0008 00-5
Error Code 1313 - Injector Circuit Failure.....	0008 00-8
Error Code 1314 - Injector Circuit Failure.....	0008 00-12
Error Code 1315 - Injector Circuit Failure.....	0008 00-15
Error Code 1321 - Injector Circuit Failure.....	0008 00-19
Error Code 1322 - Injector Circuit Failure.....	0008 00-22
Error Code 1323 - Injector Circuit Failure.....	0008 00-30
Error Code 1324 - Injector Circuit Failure.....	0008 00-38
Error Code 1325 - Injector Circuit Failure.....	0008 00-46
Error Code 1331 - Injector Circuit Failure.....	0008 00-54
Error Code 1332 - Injector Circuit Failure.....	0008 00-62
Error Code 1951 - Injector Circuit Failure.....	0008 00-70

ENGINE FUEL PRESSURE SENSORS AND CIRCUITS

Error Code 1254 - Fuel Shutoff Solenoid Circuit Failure.....	0024 00-1
Error Code 1255 - Fuel Shutoff Solenoid External Voltage Detected on Circuit.....	0024 00-7
Error Code 1581 - Fuel Inlet Restriction Sensor Circuit Failure.....	0024 00-9

ENGINE ELECTRONIC CONTROL UNIT (ECU) (791)

Error Code 1187 - Sensor Voltage Supply Failure.....	0018 00-1
Error Code 1227 - Sensor Voltage Supply Failure.....	0018 00-6
Error Code 1287 - Sensor Voltage Supply Failure.....	0018 00-13
Error Code 1352 - Sensor Voltage Supply Failure.....	0018 00-13
Error Code 1443 - Low Voltage Detected at Throttle Position Sensor Circuit.....	0018 00-17

ENGINE OIL PRESSURE SENSOR

Error Code 1135 - Oil Pressure Sensor Circuit Failure.....	0020 00-1
Error Code 1141 - Oil Pressure Sensor Circuit Failure.....	0020 00-7
Error Code 1143 - Oil Pressure Sensor Circuit Failure.....	0020 00-13
Error Code 1415 - Oil Pressure Sensor Circuit Failure.....	0020 00-13
Error Code 1435 - Oil Pressure Sensor Circuit Failure.....	0020 00-14

ENGINE POSITION SENSOR CIRCUITS

Error Code 1115 - Engine Position Sensor Circuit Failure.....	0019 00-1
Error Code 1121 - Engine Position Sensor Circuit Failure.....	0019 00-5
Error Code 1234 - Engine Overspeed Failure.....	0019 00-9

ENGINE PRESSURE SENSOR

Error Code 1122 - Intake Manifold Pressure Sensor Circuit Failure.....	0023 00-1
Error Code 1123 - Intake Manifold Pressure Sensor Circuit Failure.....	0023 00-9
Error Code 1419 - Intake Manifold Pressure Sensor Circuit Failure.....	0023 00-14
Error Code 1433 - Intake Manifold Pressure Sensor Circuit Failure.....	0023 00-14

ERROR CODE SYMPTOM INDEX - CONTINUED

Malfunction/Symptom **Troubleshooting Procedure Page**

ENGINE TEMPERATURE SENSORS AND CIRCUITS

Error Code 1144 - Coolant Temperature Sensor Circuit Failure. 0021 00-2
 Error Code 1145 - Coolant Temperature Sensor Circuit Failure. 0021 00-6
 Error Code 1151 - Coolant Temperature Sensor Circuit Failure. 0021 00-10
 Error Code 1153 - Intake Air Temperature Sensor Circuit Failure. 0021 00-10
 Error Code 1154 - Intake Air Temperature Sensor Circuit Failure. 0021 00-14
 Error Code 1155 - Intake Air Temperature Sensor Circuit Failure. 0021 00-18
 Error Code 1212 - Oil Temperature Sensor Circuit Failure. 0021 00-18
 Error Code 1213 - Oil Temperature Sensor Circuit Failure. 0021 00-22
 Error Code 1214 - Oil Temperature Sensor Circuit Failure. 0021 00-26
 Error Code 1697 - ECU Internal Temperature Sensor Circuit Failure. 0021 00-26
 Error Code 1698 - ECU Internal Temperature Sensor Circuit Failure. 0021 00-26

ENGINE TPS AND IDLE VALIDATION SWITCH

Error Code 1131 - High Voltage Detected at Throttle Position Sensor Circuit. 0009 00-1
 Error Code 1132 - Low Voltage Detected at Throttle Position Sensor Circuit. 0009 00-8
 Error Code 1431 - Voltage Detected at Both Idle Validation Signal Circuits. 0009 00-13
 Error Code 1432 - Wrong Voltage Signals Detected at Throttle Position Sensor
 and Idle Validation Circuits. 0009 00-19
 Error Code 1551 - No Voltage Detected at Both Idle Validation Signal Circuits. 0009 00-23

HYDRAULIC FILTER INDICATORS

Error Code 1 - Boom Hydraulic System Sensor Indicating Clogged Filter. 0039 00-1
 Error Code 2 - Steering Hydraulic System Sensor Indicating Clogged Filter. 0039 00-2
 Error Code 3 - Tophandler Hydraulic System Sensor Indicating Clogged Filter. 0039 00-2
 Error Code 4 - Hydraulic Reservoir Return Sensor Indicating Clogged Filter. 0039 00-3
 Error Code 432 - Boom Hydraulic Filter Sensor, Circuit Error Input. 0039 00-3
 Error Code 433 - Steering Hydraulic Filter Sensor, Circuit Input Error. 0039 00-4
 Error Code 434 - Tophandler Hydraulic Filter Sensor, Circuit Input Error. 0039 00-5
 Error Code 435 - Hydraulic Reservoir Return System Filter Sensor, Circuit Input Error. 0039 00-6
 Error Code 786 - Transmission Hydraulic System Sensor Indicating Clogged Filter. 0039 00-7

HYDRAULIC PISTON PUMP CUT-OFF

Error Code 172 - Hydraulic Piston Pump Cut-Off, Open or Short Circuit Failure. 0038 00-1

HYDRAULIC SERVO SYSTEM ELECTRONIC CONTROL UNIT (ECU) (790)

Error Code 125 - Memory Failure. 0036 00-1
 Error Code 141 - Internal Communication Failure. 0036 00-1
 Error Code 142 - Internal Communication Failure. 0036 00-2

ERROR CODE SYMPTOM INDEX - CONTINUED**Malfunction/Symptom****Troubleshooting Procedure Page****INPUT AND OUTPUT SIGNALS FOR STEERING (ECU) (792)**

Error Code 350 - Right Front Wheel Valve Solenoid Error.....	0017 00-2
Error Code 351 - Right Rear Wheel Valve Solenoid Error.	0017 00-2
Error Code 352 - Left Rear Wheel Valve Solenoid Error.	0017 00-2
Error Code 353 - Left Front Wheel Valve Solenoid Error.	0017 00-3
Error Code 354 - Right Front Wheel Valve Solenoid Error.....	0017 00-3
Error Code 355 - Right Rear Wheel Valve Solenoid Error.	0017 00-3
Error Code 356 - Left Rear Wheel Valve Solenoid Error.	0017 00-4
Error Code 357 - Right Front Wheel Valve Solenoid Error.....	0017 00-4
Error Code 399 - EEPROM Parameter Error in ECU (792).	0017 00-4
Error Code 401 - Transmission Neutral Signal from Steering ECU (792) Short Circuit Failure.	0017 00-5
Error Code 404 - 2WD Steering Control Lamp, Short Circuit Failure.	0017 00-5
Error Code 405 - 4WD Steering Control Lamp, Short Circuit Failure.	0017 00-6
Error Code 406 - Crab Steering Control Lamp, Short Circuit Failure.....	0017 00-8
Error Code 408 - Unlocked Twistlock Control Lamp, Short Circuit Failure.....	0017 00-9
Error Code 409 - Locked Twistlock Control Lamp, Short Circuit Failure.	0017 00-10
Error Code 410 - Alignment Control Lamp, Short Circuit Failure.	0017 00-11
Error Code 412 - Autolube Pump Control, Short Circuit Failure (USMC Only).	0017 00-12
Error Code 413 - Boom Folding Supply Valve, Short Circuit Failure.....	0017 00-13
Error Code 415 - Drag Restriction, Short Circuit Failure (RESET or USMC Only).	0017 00-14
Error Code 416 - Steering Pressure Switch, Circuit Input Error.	0017 00-14
Error Code 418 - 2WD Steering Selection Switch, Circuit Input Error.....	0017 00-16
Error Code 419 - 4WD Steering Selection Switch, Circuit Failure.....	0017 00-17
Error Code 420 - Crab Steering Selection Switch, Circuit Failure.	0017 00-18
Error Code 422 - Cab in Transport Proximity Switch, Circuit Input Error.	0017 00-19
Error Code 423 - Ether Start Switch, Circuit Failure.....	0017 00-20
Error Code 427 - Tophandler Work Light Switch, Circuit Input Error.	0017 00-21
Error Code 440 - Steering Wheel Sensor, Power Supply Error (RESET or USMC Only).	0017 00-22
Error Code 450 - Temperature Inside Steering ECU (792) Above Critical Threshold [184°F (85°C)].. . . .	0017 00-23

INTERNAL TRANSMISSION CLUTCH SLIPPAGE FAILURE

Error Code 777 - Internal Transmission Failure at Clutch K1.....	0030 00-1
Error Code 778 - Internal Transmission Failure at Clutch K2.....	0030 00-2
Error Code 779 - Internal Transmission Failure at Clutch K3.....	0030 00-2
Error Code 780 - Internal Transmission Failure at Clutch K4.....	0030 00-3
Error Code 781 - Internal Transmission Failure at Clutch KV.....	0030 00-3
Error Code 782 - Internal Transmission Failure at Clutch KR.	0030 00-4
Error Code 845 - Clutch Failure Detected During Calibration.	0030 00-4
Error Code 846 - Clutch Adjustment Data Lost.....	0030 00-4

ERROR CODE SYMPTOM INDEX - CONTINUED

Malfunction/Symptom **Troubleshooting Procedure Page**

MECHANICAL OR HYDRAULIC STEERING FAILURE

Error Code 317 - Right-Front Wheel Angle Cannot Reach Set Point Value. 0034 00-1
 Error Code 318 - Right-Rear Wheel Angle Cannot Reach Set Point Value. 0034 00-2
 Error Code 319 - Left-Rear Wheel Angle Cannot Reach Set Point Value. 0034 00-2
 Error Code 320 - Left-Front Wheel Angle Cannot Reach Set Point Value. 0034 00-3
 Error Code 321 - Right-Front Wheel is Not Calibrated Correctly. 0034 00-3
 Error Code 322 - Right-Rear Wheel is Not Calibrated Correctly. 0034 00-3
 Error Code 323 - Left-Rear Wheel is Not Calibrated Correctly. 0034 00-4
 Error Code 324 - Left-Front Wheel is Not Calibrated Correctly. 0034 00-4

MISCELLANEOUS TRANSMISSION FAILURE

Error Code 618 - Signal from Gear Selector Not Correct. 0029 00-1
 Error Code 622 - Feedback Signal from 2WD/4WD Switch Not Correct. 0029 00-3
 Error Code 745 - Backup Alarm Control Circuit, Short Circuit to Chassis Failure. 0029 00-4
 Error Code 746 - Backup Alarm Control Circuit, Short Circuit to Battery Failure. 0029 00-5
 Error Code 747 - Backup Alarm Control Circuit, Open Circuit Failure. 0029 00-5
 Error Code 761 - 2WD/4WD Connection Valve Circuit, Short Circuit to Chassis Failure. 0029 00-6
 Error Code 762 - 2WD/4WD Connection Valve Circuit, Short Circuit to Battery Failure. 0029 00-7
 Error Code 763 - 2WD/4WD Connection Valve Circuit, Open Circuit Failure. 0029 00-8

OVERLOAD PROTECTION

Error Code 130 - Overload Protection System Failure. 0011 00-1
 Error Code 131 - Boom Extension Sensor or Circuit Failure. 0011 00-2
 Error Code 132 - Boom Angle Sensor or Circuit Failure. 0011 00-4
 Error Code 133 - Left Lift Cylinder Pressure Sensor or Circuit Failure. 0011 00-5
 Error Code 134 - Right Lift Cylinder Pressure Sensor or Circuit Failure. 0011 00-7
 Error Code 135 - Left Lift Cylinder Piston Pressure Sensor or Circuit Failure. 0011 00-9
 Error Code 136 - Right Lift Cylinder Piston Pressure Sensor or Circuit Failure. 0011 00-11
 Error Code 210 - Tophandler Angle Sensor or Circuit Failure. 0011 00-13

STEERING ECU (792), TRANSMISSION ECU (793), AND ENGINE ECU (794)

Error Code 300 - Steering ECU (792) Hardware Failure. 0015 00-1
 Error Code 841 - Transmission ECU (793) Memory Failure. 0015 00-3
 Error Code 843 - Application Error Failure. 0015 00-3
 Error Code 1111 - Engine ECU (794) Memory Failure. 0015 00-3
 Error Code 1341 - Engine ECU (794) Loss of Data Failure. 0015 00-4
 Error Code 1343 - Engine ECU (794) Internal Communication Failure. 0015 00-7
 Error Code 1346 - Engine ECU (794) Software Failure. 0015 00-10

ERROR CODE SYMPTOM INDEX - CONTINUED

Malfunction/Symptom **Troubleshooting Procedure Page**

STEERING SENSOR

Error Code 301 - Right-Front Wheel Sensor Circuit Failure.....	0035 00-2
Error Code 302 - Right-Rear Wheel Sensor Circuit Failure.	0035 00-3
Error Code 303 - Left-Rear Wheel Sensor Circuit Failure.	0035 00-4
Error Code 304 - Left-Front Wheel Sensor Circuit Failure.....	0035 00-5
Error Code 305 - Right-Front Wheel Sensor Circuit Failure.....	0035 00-6
Error Code 306 - Right-Rear Wheel Sensor Circuit Failure.	0035 00-7
Error Code 307 - Left-Rear Wheel Sensor Circuit Failure.	0035 00-8
Error Code 308 - Left-Front Wheel Sensor Circuit Failure.....	0035 00-9
Error Code 309 - Right-Front Wheel Sensor Circuit Failure.....	0035 00-10
Error Code 310 - Right-Rear Wheel Sensor Circuit Failure.	0035 00-11
Error Code 311 - Left-Rear Wheel Sensor Circuit Failure.....	0035 00-13
Error Code 312 - Left-Front Wheel Sensor Circuit Failure.....	0035 00-14
Error Code 313 - Right-Front Wheel Sensor Circuit Failure.....	0035 00-16
Error Code 314 - Right-Rear Wheel Sensor Circuit Failure.	0035 00-16
Error Code 315 - Left-Rear Wheel Sensor Circuit Failure.	0035 00-16
Error Code 316 - Left-Front Wheel Sensor Circuit Failure.....	0035 00-17
Error Code 339 - Grounding of Steering Wheel Sensor is Interrupted (USMC Only).	0035 00-17

STEERING VALVE CIRCUIT

Error Code 325 - Right-Front Wheel Valve Solenoid, Broken Circuit Failure.	0033 00-1
Error Code 326 - Right-Rear Wheel Valve Solenoid, Broken Circuit Failure.....	0033 00-3
Error Code 327 - Left-Rear Wheel Valve Solenoid, Broken Circuit Failure.....	0033 00-4
Error Code 328 - Left-Front Wheel Valve Solenoid, Broken Circuit Failure.	0033 00-6
Error Code 329 - Right-Front Wheel Valve Solenoid, Short Circuit Failure.....	0033 00-7
Error Code 330 - Right-Rear Wheel Valve Solenoid, Short Circuit Failure.	0033 00-9
Error Code 331 - Left-Rear Wheel Valve Solenoid, Short Circuit Failure.	0033 00-10
Error Code 332 - Left-Front Wheel Valve Solenoid, Short Circuit Failure.....	0033 00-12
Error Code 339 - Grounding of Steering Wheel Sensor is Interrupted (USMC Only).	0033 00-13
Error Code 340 - Hydraulic Steering Pressure Below Threshold [1,450 psi (100 Bar)].	0033 00-14
Error Code 341 - Steering Wheel Signal Not Consistent.....	0033 00-16
Error Code 342 - One Steering Wheel Signal is Interrupted.	0033 00-17
Error Code 343 - One Steering Wheel Signal is Interrupted.	0033 00-17
Error Code 344 - Both Steering Wheel Signals are Interrupted.....	0033 00-17
Error Code 347 - No Steering Mode Selected.	0033 00-17

TOPHANDLER ELECTRONIC CONTROL UNIT (ECU) (791)

Error Code 205 - Memory Failure.	0012 00-1
Error Code 220 - Internal Communication Failure, Connector 2.	0012 00-1
Error Code 221 - Internal Communication Failure, Connector 2.	0012 00-2
Error Code 250 - Internal Communication Failure, Connector 3.	0012 00-2
Error Code 251 - Internal Communication Failure, Connector 3.	0012 00-2

ERROR CODE SYMPTOM INDEX - CONTINUED

Malfunction/Symptom **Troubleshooting Procedure Page**

TOPHANDLER LEVELING

Error Code 128 - Joystick-to-ECU (790) Failure. 0044 00-1
 Error Code 130 - Overload Protection System Failure. 0044 00-2
 Error Code 240 - Tophandler Leveling Locking Control, Wiring Circuit Failure. 0044 00-3
 Error Code 267 - Tophandler Leveling Right, Open Circuit Failure. 0044 00-4
 Error Code 268 - Tophandler Leveling Right, Short Circuit Failure. 0044 00-5
 Error Code 270 - Tophandler Leveling Left, Open Circuit Failure. 0044 00-6
 Error Code 271 - Tophandler Leveling Left, Short Circuit Failure. 0044 00-7

TOPHANDLER SIDESHIFT

Error Code 225 - Tophandler Sideshift Left, Open Circuit Failure. 0045 00-1
 Error Code 226 - Tophandler Sideshift Left, Short Circuit Failure. 0045 00-3
 Error Code 228 - Tophandler Sideshift Right, Open Circuit Failure. 0045 00-4
 Error Code 229 - Tophandler Sideshift Right, Short Circuit Failure. 0045 00-5

TOPHANDLER SLEWING

Error Code 128 - Joystick-to-ECU (790) Failure. 0042 00-1
 Error Code 130 - Overload Protection System Failure. 0042 00-2
 Error Code 255 - Tophandler Clockwise Slewing, Wiring Circuit Failure. 0042 00-3
 Error Code 256 - Tophandler Clockwise Slewing, Component Failure. 0042 00-4
 Error Code 258 - Tophandler Counterclockwise Slewing, Wiring Circuit Failure. 0042 00-5
 Error Code 259 - Tophandler Counterclockwise Slewing, Component Failure. 0042 00-6

TOPHANDLER SPREADER

Error Code 231 - Tophandler Spreader Opening, Open Circuit Failure. 0046 00-1
 Error Code 232 - Tophandler Spreader Opening, Short Circuit Failure. 0046 00-3
 Error Code 234 - Tophandler Spreader Closing, Open Circuit Failure. 0046 00-4
 Error Code 235 - Tophandler Spreader Closing, Short Circuit Failure. 0046 00-5

TOPHANDLER TILT

Error Code 129 - Joystick-to-ECU (790) Failure. 0043 00-1
 Error Code 130 - Overload Protection System Failure. 0043 00-2
 Error Code 237 - Tophandler Tilt Locking Control, Wiring Circuit Failure. 0043 00-3
 Error Code 261 - Tophandler Tilt OUT Control, Wiring Circuit Failure. 0043 00-4
 Error Code 262 - Tophandler Tilt OUT Control, Component Failure. 0043 00-5
 Error Code 264 - Tophandler Tilt IN Control, Wiring Circuit Failure. 0043 00-6
 Error Code 265 - Tophandler Tilt IN Control, Component Failure. 0043 00-7

TOPHANDLER TWISTLOCKS AND FORKLIFT SENSOR

Error Code 212 - Tophandler Left Twistlocks Indication Failure. 0047 00-1
 Error Code 213 - Tophandler Right Twistlocks Indication Failure. 0047 00-3
 Error Code 214 - Tophandler Forklift Sensor Indication Failure. 0047 00-5
 Error Code 243 - Tophandler Twistlock Locking Circuit Failure. 0047 00-6
 Error Code 246 - Tophandler Twistlock Unlocking Circuit Failure. 0047 00-8

ERROR CODE SYMPTOM INDEX - CONTINUED

Malfunction/Symptom	Troubleshooting Procedure Page
----------------------------	---------------------------------------

TRANSMISSION CLUTCH CIRCUIT

Error Code 713 - Clutch K1 Short Circuit to Battery Failure.	0028 00-2
Error Code 714 - Clutch K1 Short Circuit to Chassis Failure.	0028 00-3
Error Code 715 - Clutch K1 Open Circuit Failure.	0028 00-4
Error Code 716 - Clutch K2 Short Circuit to Battery Failure.	0028 00-5
Error Code 717 - Clutch K2 Short Circuit to Chassis Failure.	0028 00-6
Error Code 718 - Clutch K2 Open Circuit Failure.	0028 00-7
Error Code 719 - Clutch K3 Open Circuit to Battery Failure.	0028 00-8
Error Code 720 - Clutch K3 Short Circuit to Chassis Failure.	0028 00-9
Error Code 721 - Clutch K3 Open Circuit Failure.	0028 00-10
Error Code 729 - Clutch K4 Short Circuit to Battery Failure.	0028 00-11
Error Code 730 - Clutch K4 Short Circuit to Chassis Failure.	0028 00-12
Error Code 731 - Clutch K4 Open Circuit Failure.	0028 00-13
Error Code 732 - Clutch KV Short Circuit to Battery Failure.	0028 00-14
Error Code 733 - Clutch KV Short Circuit to Chassis Failure.	0028 00-15
Error Code 734 - Clutch KV Open Circuit Failure.	0028 00-16
Error Code 735 - Clutch KR Short Circuit to Battery Failure.	0028 00-17
Error Code 736 - Clutch KR Short Circuit to Chassis Failure.	0028 00-18
Error Code 737 - Clutch KR Open Circuit Failure.	0028 00-19

TRANSMISSION SPEED SENSORS

Error Code 649 - Engine Speed Sensor Failure, Open Circuit or Short Circuit to Battery.	0027 00-2
Error Code 650 - Engine Speed Sensor Failure, Short Circuit to Chassis.	0027 00-3
Error Code 651 - Engine Speed Sensor Failure, Logical Error.	0027 00-4
Error Code 652 - Turbine Speed Sensor Failure, Open Circuit or Short Circuit to Battery.	0027 00-4
Error Code 653 - Turbine Speed Sensor Failure, Short Circuit to Chassis.	0027 00-6
Error Code 654 - Turbine Speed Sensor Failure, Logical Error.	0027 00-7
Error Code 655 - Internal Speed Sensor Failure, Open Circuit or Short Circuit to Battery.	0027 00-7
Error Code 656 - Internal Speed Sensor Failure, Short Circuit to Chassis.	0027 00-8
Error Code 657 - Internal Speed Sensor Failure, Logical Error.	0027 00-9
Error Code 658 - Output Speed Sensor Failure, Open Circuit or Short Circuit to Battery.	0027 00-9
Error Code 659 - Output Speed Sensor Failure, Short Circuit to Chassis.	0027 00-10
Error Code 660 - Output Speed Sensor Failure, Logical Error.	0027 00-11
Error Code 662 - Output Speed Sensor Failure, Logical Speed Error.	0027 00-11

ERROR CODE SYMPTOM INDEX - CONTINUED

Malfunction/Symptom **Troubleshooting Procedure Page**

TRANSMISSION TEMPERATURE

Error Code 637 - Transmission Sump Temperature Sensor Failure, Open Circuit or Short Circuit to Battery.	0026 00-1
Error Code 638 - Transmission Sump Temperature Sensor Failure, Short Circuit to Chassis.	0026 00-2
Error Code 639 - Converter Output Temperature Sensor Failure, Open Circuit, or Short Circuit to Battery.	0026 00-3
Error Code 640 - Converter Output Temperature Sensor Failure, Short Circuit to Chassis.	0026 00-4
Error Code 783 - Sump Temperature Critical Threshold [212°F (100°C)] Failure.	0026 00-5
Error Code 795 - Converter Output Temperature Critical Threshold [248°F (120°C)] Failure.	0026 00-6

TROUBLESHOOTING PROCEDURES (NON-ERROR CODE)

Engine Troubleshooting Procedures (Non-Error Code)

Engine Will Not Crank.....	0007 00-1
Engine Will Crank but Will Not Start (Exhaust Smoke or No Exhaust Smoke).....	0007 00-5
Excessive Exhaust Smoke - White.....	0007 00-5
Excessive Exhaust Smoke - Black.....	0007 00-6
Engine Acceleration - Poor.....	0007 00-7
Engine Deceleration - Poor.....	0007 00-8
Engine Performance (Power) - Low.....	0007 00-8
Engine Runs Rough.....	0007 00-9
Engine Speed Surges (Idle or Under Load).....	0007 00-10
Engine Shuts Off Unexpectedly.....	0007 00-11
Engine Starts but Will Not Keep Running.....	0007 00-12
Engine Vibration Excessive.....	0007 00-13
Fuel Consumption Excessive.....	0007 00-13
Engine Overheats.....	0007 00-14
Engine Oil Pressure - Low.....	0007 00-15
Engine Oil Pressure - High.....	0007 00-16
Engine Cold Start System Not Working.....	0007 00-16

Electrical Troubleshooting Procedures (Non-Error Code)

Headlight(s) (High or Low Beam) Do Not Operate When Switch is Turned On.....	0007 00-19
Front/Rear Side Marker Light(s) or Taillights(s) Do Not Operate When Headlight Switch is Turned On.....	0007 00-20
Stoplight(s) Do Not Operate When Brake Pedal is Pressed.....	0007 00-22
Turn Signals or Emergency Flashers are Not Working.....	0007 00-25
Blackout Drive and Marker Lights Do Not Operate When Switch is Turned On.....	0007 00-27
Blackout Stoplights Not Working.....	0007 00-29
Horn Will Not Sound When Button is Pressed.....	0007 00-30
Backup Lights/Alarm Does Not Operate When Vehicle Placed in Reverse.....	0007 00-31
Boom Work Light(s) Do Not Operate When Switch is Turned On.....	0007 00-33
Tophandler Work Light(s) Do Not Operate When Switch is Turned On.....	0007 00-35
IR Work Light(s) Do Not Operate When Switch is Turned On.....	0007 00-37
Front Windshield Wiper Motor Not Working.....	0007 00-39
Rear Windshield Wiper Motor Not Working.....	0007 00-41
Roof Windshield Wiper Motor Not Working.....	0007 00-43
Windshield Washer Not Working.....	0007 00-44
Cab Interior Light Not Working.....	0007 00-45
12V Utility Plug Not Working.....	0007 00-46
Blower Motor Not Working.....	0007 00-47
Heater/Defroster Producing Low or No Heat.....	0007 00-49
A/C System Not Cooling Properly.....	0007 00-50
Fuel Gage Not Working Properly.....	0007 00-52
Driver's ECS Display Screen Will Not Display.....	0007 00-54
After Key "On" Functions Not Working (No Crank, Display, etc.).....	0007 00-54

TROUBLESHOOTING SYMPTOM INDEX - CONTINUED

0006 00

TROUBLESHOOTING PROCEDURES (NON-ERROR CODE) - CONTINUED

Electrical Troubleshooting Procedures (Non-Error Code) - Continued

Malfunction/Symptom	Troubleshooting Procedure Page
Proximity Switches - Tophandler and Cab.....	0007 00-57
Normal Functions Operate in Blackout Mode.....	0007 00-61
Multiple Boom or Tophandler Functions Not Working (Multiple Error Codes).....	0007 00-61
Function(s) Work Uncontrolled.....	0007 00-65
Brake System Troubleshooting Procedures (Non-Error Code)	
Braking is Poor or Nonexistent.....	0007 00-67
Parking Brake Will Not Release.....	0007 00-67
Parking Brake Will Not Engage.....	0007 00-68
Steering System Troubleshooting Procedures (Non-Error Code)	
Steering Control is Poor or Nonexistent.....	0007 00-69
Operator's Cab Troubleshooting Procedures (Non-Error Code)	
Operator's Cab Will Not Move To or From Transport Position Properly.....	0007 00-70
Auxiliary Pump Troubleshooting Procedures (Non-Error Code)	
Auxiliary Pump Not Working.....	0007 00-71
Boom System Troubleshooting Procedures (Non-Error Code)	
Boom Will Not Lift or Lower Properly.....	0007 00-74
Boom Will Not Extend or Retract Properly.....	0007 00-75
Boom Folding Cylinders Not Working.....	0007 00-76
Boom Locking Pin Cylinders Not Working.....	0007 00-77
Tophandler System Troubleshooting Procedures (Non-Error Code)	
Tophandler Will Not Tilt Forward or Rearward Properly.....	0007 00-79
Tophandler Will Not Oscillate (Level) Properly.....	0007 00-80
Tophandler Will Not Sideshift Properly.....	0007 00-81
Tophandler Spreader Will Not Open or Close Properly.....	0007 00-82
Tophandler Will Not Rotate Left or Right Properly.....	0007 00-84
Tophandler Twistlocks Will Not Rotate Properly.....	0007 00-85
Bogie Wheel System Troubleshooting Procedures (Non-Error Code)	
Bogie Wheels Will Not Lift or Lower.....	0007 00-88
Forklift Kit Troubleshooting Procedures (Non-Error Code)	
Fork Functions Not Working Properly.....	0007 00-89
Autolube System Not Lubricating Properly (USMC Only) Troubleshooting Procedures (Non-Error Code)	
Autolube System Not Lubricating Properly (USMC Only).....	0007 00-90
Autolube Pump Not Working (USMC Only).....	0007 00-91
Solar Charger Not Working (USMC Only).....	0007 00-93

END OF WORK PACKAGE

NOTE

Refer to WP 0004 00 for additional troubleshooting guidance, information, and illustrations that locate critical components.

Table 1. Engine Troubleshooting Procedures (Non-Error Code).





MALFUNCTION	TEST OR INSPECTION	CORRECTIVE ACTION
<p>1. Engine Will Not Crank.</p>	<p>1. Check transmission shift level is in Neutral and master switch is on.</p> <p>2. Check circuit breaker numbers 2 and 8 are not tripped.</p> <div style="display: flex; justify-content: space-around; align-items: center;">   <div style="text-align: center;"> <p>WARNING</p> <p>To avoid injury, eye protection and acid-resistant gloves must be worn when working around batteries. DO NOT smoke, use open flame, make sparks, or create other ignition sources around batteries. If a battery is giving off gases, it can explode and cause injury to personnel. Remove all jewelry such as rings, ID tags, watches, and bracelets. If jewelry or a tool contacts a battery terminal, a direct short will result in instant heating or electrical shock, damage to equipment, and injury to personnel.</p> </div>  </div> <p>3. Check for damaged or loose battery connections. Check battery voltage. Normal voltage can be 23 to 27V.</p> <div style="display: flex; justify-content: space-around; align-items: center;">  <div style="text-align: center;"> <p>WARNING</p> <p>Eye protection must be worn when working under vehicle to avoid injury to personnel.</p> </div> </div> <p>4. Check voltage at starter terminal 30.</p>	<p>Place transmission shift lever to neutral or master switch to on position.</p> <p>Reset circuit breakers as required (WP 0074 00).</p> <p>Tighten or repair battery connections (WP 0110 00).</p> <p>If no voltage is found, check wiring back to master switch and batteries (WP 0048 00-33).</p>

Table 1. Engine Troubleshooting Procedures (Non-Error Code) - Continued.

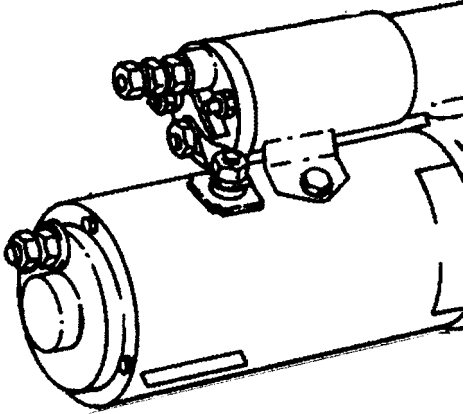
MALFUNCTION	TEST OR INSPECTION	CORRECTIVE ACTION
<p>1. Engine Will Not Crank - Continued.</p>	<p>5. Check voltage (24V) at starter solenoid on starter at wire W11 of S terminal while turning the ignition switch to crank (WP 0048 00-31).</p>	<p>a. If no voltage (24V) is found, check circuit breaker numbers F50-1 and F50-2 for loose or damaged connections.</p> <p>b. If voltage is present (24V), check starter and starter solenoid for shorts or damage. Replace shorted or damaged starter and solenoid (WP 0072 00).</p>
 <p>434-40171</p>		
	<p>6. Check starter relay 360 for shorts, opens, or damage (WP 0113 00).</p> <p>7. Check voltage (24V) at XK2 pin 7 while turning the ignition switch to crank (WP 0048 00-31).</p>	<p>Replace shorted, open, or damaged relay (WP 0074 00).</p> <p>a. If voltage (24V) is not found, check voltage at X8 pin 3 (WP 0048 00-31).</p> <p>b. If voltage (24V) is present at X8 pin 3, unplug X8 and check continuity at the loose part of X8 between pin 2 and 3 with the ignition switch turned to crank (WP 0048 00-31).</p>

Table 1. Engine Troubleshooting Procedures (Non-Error Code) - Continued.

MALFUNCTION	TEST OR INSPECTION	CORRECTIVE ACTION
<p>1. Engine Will Not Crank - Continued.</p>	<p>8. Check voltage (24V) at XK12 pin 4 while turning the ignition switch to crank.</p> <p>9. Test relays. Remove relays 330 and 330-1 and test (WP 0113 00). With the relays removed, check continuity between: XK2 pin 7 and 330 pin 30, XK2 pin 1 and 330 pin 87, XK2 pin 2 and 330 pin 86, XK2 pin 5 and 330 pin 85, XK12 pin 7 and 330-1 pin 30, XK12 pin 4 and 330-1 pin 87a, and XK12 pin 2 and 330-1 pin 86, and XK12 pin 5 and 330-1 pin 85 (WP 0048 00-31).</p>	<p>c. If no continuity, access the ignition switch in the driver's console. Check ignition switch for damage and continuity and check continuity of wires 82, 83, and A27 (WP 0048 00-31).</p> <p>d. Replace damaged or faulty ignition switch (WP 0073 00).</p> <p>e. Repair or replace damaged wires or connectors (WP 0113 00).</p> <p>a. If voltage (24V) is not found, check voltage (24V) at XK2 pin 2 (WP 0048 00-31), X28 pins 4, 9, and 7 (WP 0048 00-35) with ignition switch on.</p> <p>b. Unplug X28 and check continuity of shift lever at the loose part of X28 between pin 9 and 7 with the shift lever in Neutral (WP 0048 00-35).</p> <p>c. Check continuity of wires 287, 289, and A22 (WP 0048 00-35).</p> <p>d. Replace damaged or faulty shift lever (WP 0114 00).</p> <p>e. Repair or replace damaged wires or connectors (WP 0113 00).</p> <p>a. Replace shorted, open, or damaged relay (WP 0074 00).</p> <p>b. Replace any damaged or burnt relay boards (WP 0074 00).</p> <p>c. Check continuity of wires A21, A171, 171, and W12 (WP 0048 00-31).</p> <p>d. Repair or replace damaged wires or connectors (WP 0113 00).</p>

Table 1. Engine Troubleshooting Procedures (Non-Error Code) - Continued.

MALFUNCTION	TEST OR INSPECTION	CORRECTIVE ACTION
<p>1. Engine Will Not Crank - Continued.</p>	<p>10. Check wiring. Remove wire 172 from the "I" terminal on the alternator. Check for continuity to ground on the alternator "I" terminal (WP 0048 00-31).</p>	<p>a. Should have continuity to ground on the alternator "I" terminal.</p> <p>b. If no continuity to ground, touch wire 172 that was removed to ground and try cranking the engine.</p> <p>c. If engine cranks, replace the alternator (WP 0070 00).</p> <p>d. If engine does not crank, check continuity of wires 172 and A25 (WP 0048 00-31).</p> <p>e. Repair or replace damaged wires or connectors (WP 0113 00).</p>

Table 1. Engine Troubleshooting Procedures (Non-Error Code) - Continued.

MALFUNCTION	TEST OR INSPECTION	CORRECTIVE ACTION
<p>2. Engine Will Crank but Will Not Start (Exhaust Smoke or No Exhaust Smoke).</p>	<ol style="list-style-type: none"> 1. Check fuel line shutoff valve at fuel filter (RESET or USMC). 2. Check circuit breaker F13 for trip. 3. Check for damaged or leaking fuel lines, hoses, and fittings. 4. Check for clogged fuel/water separator. 5. Check for dirty or clogged air cleaner element. 6. Perform cold starting procedures (TM 10-3930-675-10). 7. Check fuel solenoid shutoff valve (FSOV). 	<p>Open fuel line shutoff valve.</p> <p>Reset F13 circuit breaker. A tripped F13 will generate error code 112 (WP 0014 00).</p> <p>Tighten or repair fuel lines, hoses, and fittings (WP 0060 00).</p> <p>Replace fuel/water separator (WP 0059 00).</p> <p>Service or replace air cleaner element (WP 0057 00).</p> <p>See cold starting system maintenance (WP 0061 00).</p> <ol style="list-style-type: none"> a. Tighten any loose connections (WP 0056 00). b. Check for voltage at FSOV (12V). c. If voltage (12V) is found, disconnect the wire and check resistance of FSOV. Resistance should be 6 to 10 Ohms. d. Replace faulty fuel solenoid shutoff valve (WP 0056 00).
<p>3. Excessive Exhaust Smoke - White.</p>	<ol style="list-style-type: none"> 1. Check and monitor engine operating temperature (low ambient temperature). 	<ol style="list-style-type: none"> a. Allow engine to warm to operating temperature. b. Check cooling fan operation. Enter into "EXTRA FUNCT" 11(13) in the diagnostic menu. Change the fan speed and observe if fan speed changes properly (0%, 33%, 66%, and 100%). Fan should run slower in low ambient temperatures.

Table 1. Engine Troubleshooting Procedures (Non-Error Code) - Continued.

MALFUNCTION	TEST OR INSPECTION	CORRECTIVE ACTION
<p>3. Excessive Exhaust Smoke - White - Continued.</p>	<p>2. Check for engine temperature sensor malfunctioning.</p> <p>3. Check for poor quality or wrong type of fuel.</p>	<p>a. Perform troubleshooting procedure for error codes 1144 and 1145 for the coolant temperature sensor (WP 0021 00).</p> <p>b. Perform troubleshooting procedure for error codes 1153 and 1154 for the intake air temperature sensor (WP 0021 00).</p> <p>a. Compare fuel used with type and grade specifications (TM 10-3930-675-10).</p> <p>b. If problem still exists, replace engine assembly (WP 0197 00).</p>
<p>4. Excessive Exhaust Smoke - Black.</p>	<p>1. Check and monitor engine operating temperature (low ambient temperature).</p> <p>2. Check for engine temperature or pressure sensor malfunctioning.</p> <p>3. Check for poor quality or wrong type of fuel.</p>	<p>a. Allow engine to warm to operating temperature.</p> <p>b. Check cooling fan operation. Enter into "EXTRA FUNCT." 11(13) in the diagnostic menu. Change the fan speed and observe if fan speed changes properly (0%, 33%, 66%, and 100%). Fan should run slower in low ambient temperatures.</p> <p>a. Perform troubleshooting procedure for error codes 1144 and 1145 for the coolant temperature sensor (WP 0021 00).</p> <p>b. Perform troubleshooting procedure for error codes 1122, 1123, and 1433 for the intake manifold pressure sensor (WP 0023 00).</p> <p>Compare fuel used with type and grade specifications (TM 10-3930-675-10).</p>

Table 1. Engine Troubleshooting Procedures (Non-Error Code) - Continued.

MALFUNCTION	TEST OR INSPECTION	CORRECTIVE ACTION
<p>4. Excessive Exhaust Smoke - Black - Continued.</p>	<p>4. Check for leaking, damaged, or restricted air intake hoses, lines, and clamps. Check for dirty or clogged air cleaner element.</p> <p>5. Check for plugged crankcase ventilation system.</p> <p>6. Check for turbocharger malfunction.</p>	<p>a. Check quality of fuel, type, and grade.</p> <p>b. Tighten or repair air intake hoses, lines, and clamps (WP 0058 00).</p> <p>c. Service or replace air cleaner element (WP 0057 00).</p> <p>Check and clean crankcase breather and tube (WP 0052 00).</p> <p>Check and replace turbocharger (WP 0217 00).</p>
<p>5. Engine Acceleration - Poor.</p>	<p>1. Check for any error codes or conditions that de-rate engine RPM.</p> <p>2. Check for leaking, damaged, or restricted air intake hoses, lines, and clamps. Check for dirty or clogged air cleaner element.</p> <p>3. Check for restricted or sticking accelerator pedal. Check operation of throttle position sensor.</p> <p>4. Check for clogged fuel/water separator or leaking fuel lines, hoses, and fittings.</p>	<p>Correct error code(s)/condition.</p> <p>a. Tighten or repair air intake hoses, lines, and clamps (WP 0058 00).</p> <p>b. Service or replace air cleaner element (WP 0057 00).</p> <p>a. Remove obstructions from accelerator pedal.</p> <p>b. Test throttle position sensor by performing the troubleshooting steps for error codes 1131 and 1132 (WP 0009 00).</p> <p>a. For RESET or USMC vehicles, ensure fuel line shutoff valve is open.</p>

Table 1. Engine Troubleshooting Procedures (Non-Error Code) - Continued.

MALFUNCTION	TEST OR INSPECTION	CORRECTIVE ACTION
<p>5. Engine Acceleration - Poor - Continued.</p>	<p>5. Check for turbocharger malfunction.</p>	<p>b. Tighten or repair fuel lines, hoses, and fittings (WP 0060 00).</p> <p>c. Replace clogged fuel/water separator (WP 0059 00).</p> <p>d. Check quality of fuel, type, and grade.</p> <p>Replace turbocharger (WP 0217 00).</p>
<p>6. Engine Deceleration - Poor.</p>	<p>1. Check for restricted or sticking accelerator pedal. Check operation of throttle position sensor.</p> <p>2. Check for leaking fuel lines, hoses, and fittings that may allow air into the fuel system.</p> <p>3. Check for any restrictions in fuel lines, hoses, and fittings.</p> <p>4. Check for turbocharger malfunction.</p>	<p>a. Remove obstructions from accelerator pedal.</p> <p>b. Test throttle position sensor by performing the troubleshooting steps for error codes 1131 and 1132 (WP 0009 00).</p> <p>Tighten or repair fuel lines, hoses, and fittings (WP 0060 00).</p> <p>a. Remove any fuel line restriction (WP 0060 00).</p> <p>b. Replace any damaged or restricted fuel line, hose, or fitting (WP 0060 00).</p> <p>Replace turbocharger (WP 0217 00).</p>
<p>7. Engine Performance (Power) - Low.</p>	<p>1. Check for any error codes or conditions that de-rate engine RPM.</p> <p>2. Check for parasitic loads on engine.</p> <p>3. Check engine oil level.</p>	<p>Correct error code(s)/condition.</p> <p>Check for brakes dragging, hydraulic malfunctions, etc.</p> <p>Verify engine oil is not overfilled (WP 0050 00).</p>

Table 1. Engine Troubleshooting Procedures (Non-Error Code) - Continued.

MALFUNCTION	TEST OR INSPECTION	CORRECTIVE ACTION
<p>7. Engine Performance (Power) - Low - Continued.</p>	<p>4. Check for clogged fuel/water separator or leaking fuel lines, hoses, and fittings that may allow air into fuel system. Check for restricted fuel lines (supply and return).</p> <p>5. Check for leaking, damaged, or restricted air intake hoses, lines, and clamps. Check for dirty or clogged air cleaner element.</p> <p>6. Check for restricted or sticking accelerator pedal. Check operation of throttle position sensor.</p>	<p>a. For RESET or USMC vehicles, ensure fuel line shutoff valve is open.</p> <p>b. Tighten or repair fuel lines, hoses, and fittings (WP 0060 00).</p> <p>c. Replace clogged fuel/water separator (WP 0059 00).</p> <p>d. Check quality of fuel, type, and grade.</p> <p>a. Tighten or repair air intake hoses, lines, and clamps (WP 0058 00).</p> <p>b. Service or replace air cleaner element (WP 0057 00).</p> <p>a. Remove obstructions from accelerator pedal.</p> <p>b. Test throttle position sensor by performing the troubleshooting steps for error codes 1131 and 1132 (WP 0009 00).</p>
<p>8. Engine Runs Rough.</p>	<p>1. Check and monitor engine operating temperature (low ambient temperature).</p>	<p>a. Allow engine to warm to operating temperature.</p> <p>b. Check cooling fan operation. Enter into "EXTRA FUNCT" 11(13) in the diagnostic menu. Change the fan speed and observe if fan speed changes properly (0%, 33% 66%, and 100%). Fan should run slower in low ambient temperatures.</p>

Table 1. Engine Troubleshooting Procedures (Non-Error Code) - Continued.

MALFUNCTION	TEST OR INSPECTION	CORRECTIVE ACTION
<p>8. Engine Runs Rough - Continued.</p>	<p>2. Check for loose or damaged engine mounts.</p> <p>3. Check for clogged fuel/water separator or leaking fuel lines, hoses, and fittings that may allow air into fuel system. Check for restricted fuel lines (supply and return).</p> <p>4. Check Engine Position Sensor (EPS) or circuit for malfunction.</p> <p>5. Check for turbocharger malfunction.</p>	<p>a. Tighten loose engine mounts.</p> <p>b. Replace engine mounts (WP 0198 00).</p> <p>a. For RESET or USMC vehicles, ensure fuel line shutoff valve is open.</p> <p>b. Tighten or repair fuel lines, hoses, and fittings (WP 0060 00).</p> <p>c. Replace clogged fuel/water separator (WP 0059 00).</p> <p>d. Check quality of fuel, type, and grade.</p> <p>Perform troubleshooting procedures for error codes 1115 and 1121 (WP 0019 00).</p> <p>Replace turbocharger (WP 0217 00).</p>
<p>9. Engine Speed Surges (Idle or Under Load).</p>	<p>1. Check for engine idle speed set too low or idling with excessive load.</p> <p>2. Check for fuel level in tank.</p> <p>3. Check for clogged fuel/water separator or leaking fuel lines, hoses, and fittings that may allow air into fuel system. Check for restricted fuel lines (supply and return).</p>	<p>Monitor idle speed; should be around 700 RPM. Check for excessive hydraulic loads at idle.</p> <p>Fill fuel tank.</p> <p>a. For RESET or USMC vehicles, ensure fuel line shutoff valve is open.</p> <p>b. Tighten or repair fuel lines, hoses, and fittings (WP 0060 00).</p> <p>c. Replace clogged fuel/water separator (WP 0059 00).</p>

Table 1. Engine Troubleshooting Procedures (Non-Error Code) - Continued.

MALFUNCTION	TEST OR INSPECTION	CORRECTIVE ACTION
<p>9. Engine Speed Surges (Idle or Under Load) - Continued.</p>	<p>4. Check for restricted or sticking accelerator pedal. Check operation of throttle position sensor.</p> <p>5. Check for leaking, damaged, or restricted air intake hoses, lines, and clamps. Check for dirty or clogged air cleaner element.</p> <p>6. Check Engine Position Sensor (EPS) or circuit for malfunction.</p>	<p>d. Check quality of fuel, type, and grade.</p> <p>a. Remove obstructions from accelerator pedal.</p> <p>b. Test throttle position sensor by performing the troubleshooting steps for error codes 1131 and 1132 (WP 0009 00).</p> <p>a. Tighten or repair air intake hoses, lines, and clamps (WP 0058 00).</p> <p>b. Service or replace air cleaner element (WP 0057 00).</p> <p>Perform troubleshooting procedures for error codes 1115 and 1121 (WP 0019 00).</p>
<p>10. Engine Shuts Off Unexpectedly.</p>	<p>1. Check for any error codes that de-rate engine RPM (for RESET or USMC vehicles, shut down after 30 seconds of de-rate).</p> <p>2. Check battery voltage.</p> <p>3. Check circuit breakers F13, F4, and F5 for trip and voltage (24V). Check for voltage at X16 pin 9 and EUC (794) pin 38 with the ignition on.</p>	<p>Error codes 1143, 1151, 1155, 1234, and 1415 will shut engine down (low oil pressure, high temp, or over speed). Correct error code using the troubleshooting procedures.</p> <p>Service batteries and connections (WP 0108 00 and WP 0110 00).</p> <p>a. Replace faulty circuit breaker (WP 0074 00).</p> <p>b. If voltage not present, check continuity of wires A169 and 169 (WP 0048 00-10).</p>

Table 1. Engine Troubleshooting Procedures (Non-Error Code) - Continued.

MALFUNCTION	TEST OR INSPECTION	CORRECTIVE ACTION
<p>10. Engine Shuts Off Unexpectedly - Continued.</p>	<p>4. Check for clogged fuel/water separator or leaking fuel lines, hoses, and fittings that may allow air into fuel system. Check for restricted fuel lines (supply and return).</p> <p>5. Check for turbocharger malfunction.</p>	<p>c. Repair any loose or missing connections (WP 0113 00). Notify SRA.</p> <p>a. Ensure fuel line shutoff valve is open (RESET or USMC).</p> <p>b. Tighten or repair fuel lines, hoses, and fittings (WP 0060 00).</p> <p>c. Replace clogged fuel/water separator (WP 0059 00).</p> <p>Check and replace turbocharger (WP 0217 00).</p>
<p>11. Engine Starts but Will Not Keep Running.</p>	<p>1. Check for any error codes that de-rate engine RPM and shut down after 30 seconds (RESET or USMC).</p> <p>2. Check fuel level in tank.</p> <p>3. Check battery voltage.</p> <p>4. Check circuit breakers F13, F4, and F5 for trip and voltage (24V). Check for voltage at X16 pin 9 and EUC (794) pin 38 with the ignition on.</p>	<p>Error codes 1143, 1151, 1155, 1234, and 1415 will shut engine down (low oil pressure, high temp, or overspeed). Correct error code using the troubleshooting procedures.</p> <p>Fill fuel tank.</p> <p>Service batteries and connections (WP 0108 00 and WP 0110 00).</p> <p>a. Replace faulty circuit breaker (WP 0074 00).</p> <p>b. If voltage not present, check continuity of wires A169 and 169 (WP 0048 00-10).</p> <p>c. Repair any loose or missing connections (WP 0113 00). Notify SRA.</p>

Table 1. Engine Troubleshooting Procedures (Non-Error Code) - Continued.

MALFUNCTION	TEST OR INSPECTION	CORRECTIVE ACTION
<p>11. Engine Starts but Will Not Keep Running - Continued.</p>	<p>5. Check for parasitic loads on engine.</p>	<p>Check for hydraulic malfunctions, etc., that cause loading on engine.</p>
<p>12. Engine Vibration Excessive.</p>	<p>6. Check for poor quality or wrong type of fuel.</p>	<p>Compare fuel used with type and grade specifications (TM 10-3930-675-10).</p>
	<p>1. Inspect for engine misfiring.</p>	<p>Perform troubleshooting procedure for <i>Engine Runs Rough</i> in this work package.</p>
	<p>2. Inspect for belt-driven accessories malfunctioning.</p>	<p>Check alternator and air conditioner compressor operation.</p>
	<p>3. Check for loose or damaged engine mounts.</p>	<p>a. Tighten loose engine mounts. b. Replace engine mounts (WP 0198 00).</p>
	<p>4. Check for loose or damaged engine vibration damper.</p>	<p>a. Tighten loose engine vibration damper. b. Replace vibration damper (WP 0203 00).</p>
<p>13. Fuel Consumption Excessive.</p>	<p>1. Check for leaking fuel lines, hoses, and fittings.</p>	<p>Tighten or repair fuel lines, hoses, and fittings (WP 0060 00).</p>
	<p>2. Check for poor quality or wrong type of fuel.</p>	<p>Compare fuel used with type and grade specifications (TM 10-3930-675-10).</p>
	<p>3. Check engine oil level.</p>	<p>Verify engine oil is not overfilled (WP 0050 00).</p>
	<p>4. Check for leaking, damaged, or restricted air intake hoses, lines, and clamps. Check for dirty or clogged air cleaner element.</p>	<p>a. Tighten or repair air intake hoses, lines, and clamps (WP 0058 00). b. Service or replace air cleaner element (WP 0057 00).</p>
	<p>5. Check for turbocharger malfunction.</p>	<p>Replace turbocharger (WP 0217 00).</p>

Table 1. Engine Troubleshooting Procedures (Non-Error Code) - Continued.

MALFUNCTION	TEST OR INSPECTION	CORRECTIVE ACTION
<p>14. Engine Overheats.</p>	<ol style="list-style-type: none"> 1. Coolant level low. 2. Check engine oil level. 3. Check radiator, radiator cap, and louvers for damage or obstructions. 4. Check coolant system for loose, damaged, leaking, or collapsed hoses. 5. Check cooling fan operation. Look in the radiator exhaust grates and observe if fan is turning while the engine is running. 6. Check status of fording switch. 	<p>Fill the coolant to the proper level in the coolant expansion tank (WP 0050 00).</p> <p>Verify engine oil is not overfilled (WP 0050 00).</p> <ol style="list-style-type: none"> a. Clean dirt and debris from radiator and louvers. b. Replace leaking radiator cap (WP 0064 00). c. Replace louvers (WP 0219 00). <ol style="list-style-type: none"> a. Inspect and tighten any loose clamps. b. Replace any damaged, leaking, or collapsed hoses (WP 0065 00). c. Replace damaged or cracked coolant expansion tank (WP 0066 00). <ol style="list-style-type: none"> a. Start engine and enter into "EXTRA FUNCT" 11(13) in the diagnostic menu. Change the fan speed and observe if fan speed changes properly (0%, 33%, 66%, and 100%). b. If fan does not change speeds, check hydraulic pressure of engine driven pump (WP 0214 00). <ol style="list-style-type: none"> a. Enter into "EXTRA FUNCT" 4(13) in the diagnostic menu. "WATER LEVEL" should indicate "1". b. If "0" is indicated, perform troubleshooting of fording switch circuit (WP 0048 00-29).

Table 1. Engine Troubleshooting Procedures (Non-Error Code) - Continued.

MALFUNCTION	TEST OR INSPECTION	CORRECTIVE ACTION
14.Engine Overheats - Continued.	<p>7. Remove engine cover to check thermostat operation.</p> <p>8. Check water pump operation by observing coolant flow in the coolant expansion tank while the engine is running.</p>	<p>a. With the engine cold, connect a 3/8 in. (10 mm) hose to the barbed bleeder valve on the metal line coming from top of hose to radiator thermostat housing.</p> <p>b. Open the coolant expansion tank and place the other end of the hose in the top of the tank and hold. Open the bleeder valve.</p> <p>c. Start the engine and observe the coolant flow from the hose. Coolant flow should not exceed 4 oz (0.12 L) per minute.</p> <p>d. Run the engine until it reaches operating temperature. The coolant flow should increase when the thermostat opens.</p> <p>e. Replace the thermostat if the coolant does not flow at operating temperature or flow exceeds 4 oz (0.12 L) per minute with the engine cold.</p> <p>a. Inspect water pump for leakage at weep hole. Unplug the weep hole if found plugged with debris.</p> <p>b. If no flow is observed in the coolant expansion tank or the pump is leaking, replace water pump (WP 0068 00).</p>
15. Engine Oil Pressure - Low.	<p>1. Check engine oil level.</p> <p>2. Check engine for external oil leaks.</p>	<p>Verify engine oil is not low or overfilled (WP 0050 00).</p> <p>a. Tighten any leaking lines or fittings.</p> <p>b. Replace any damaged or leaking lines or fittings.</p>

Table 1. Engine Troubleshooting Procedures (Non-Error Code) - Continued.

MALFUNCTION	TEST OR INSPECTION	CORRECTIVE ACTION
<p>15.Engine Oil Pressure - Low - Continued.</p>	<p>3. Check for any error codes that de-rate engine RPM (for RESET or USMC vehicles, shut down after 30 seconds of de-rate).</p> <p>4. Check if engine oil is contaminated or does not meet specifications for current operating conditions.</p>	<p>c. Pressure wash engine and check repairs for leaks.</p> <p>Error codes 1143 and 1145 will shut engine down (low oil). Correct error code using the troubleshooting procedures.</p> <p>a. Take an oil sample and have it tested for contaminants, type, and specifications (WP 0050 00).</p> <p>b. Change oil and filter (WP 0050 00).</p>
<p>16. Engine Oil Pressure - High.</p>	<p>Check if engine oil is contaminated or does not meet specification for current operating conditions.</p>	<p>Replace engine oil and filter WP 0050 00).</p>
<p>17. Engine Cold Start System Not Working.</p>	<p>1. Check circuit breaker F17 for trip.</p> <p>2. Remove engine cover and check cold start ether canister, system tubing, activation solenoid, and engine temperature sensor for damage.</p> <p>3. Check cold start system wiring in engine compartment, inspect wiring and connections at the activation solenoid and engine temperature sensor.</p>	<p>a. Reset circuit breaker.</p> <p>b. Replace faulty circuit breaker (WP 0074 00).</p> <p>a. Replace empty or missing canister (WP 0061 00).</p> <p>b. Replace any damaged or disconnected tubing (WP 0061 00).</p> <p>c. Replace damaged activation solenoid or engine temperature sensor (WP 0061 00).</p> <p>Repair any loose or missing connections (WP 0113 00).</p>

Table 1. Engine Troubleshooting Procedures (Non-Error Code) - Continued.

MALFUNCTION	TEST OR INSPECTION	CORRECTIVE ACTION
<p>17.Engine Cold Start System Not Working - Continued.</p>	<p>4. Check cold start system components.</p> <p>a. Unplug the activation solenoid and check resistance between the two pins.</p> <p>b. Check continuity between each pin and ground.</p> <p>c. Unplug the engine temperature sensor and check continuity between the two pins.</p> <p>5. Check cold start system voltage in engine compartment.</p> <p>a. Remove the ether canister from activation solenoid.</p> <p>b. Press the cold start switch. You should hear the activation solenoid “click”.</p> <p>c. Unplug the activation solenoid and check for voltage (24V) while pressing the cold start system switch.</p> <p>6a. Ensure the ether canister is removed from the activation solenoid for steps 6 through 8.</p> <p>6b. Enter “EXTRA FUNC” 8(13) in the diagnostic menu.</p>	<p>The resistance should be 3 to 4 Ohms.</p> <p>There should not be any continuity.</p> <p>There should be continuity up to 120°F (49°C). Replace open or shorted activation solenoid or engine temperature sensor (WP 0061 00).</p> <p>a. If voltage (24V) is found at activation solenoid, replace activation solenoid (WP 0061 00).</p> <p>b. If no voltage (24V) is found, check continuity of wires 162, W12B, and W12A where they connect to 360 start solenoid pin 85.</p> <p>a. If “1” indication does not appear, continue with step 7.</p> <p>b. If “1”, continue with step 8.</p>

Table 1. Engine Troubleshooting Procedures (Non-Error Code) - Continued.

MALFUNCTION	TEST OR INSPECTION	CORRECTIVE ACTION
<p>17.Engine Cold Start System Not Working - Continued.</p>	<p>7. Check for voltage (24V) at X67 pin 1 and 4 with the ignition on (WP 0048 00-47).</p> <p>8. Check for voltage (24V) at X16 pin 2 with the ignition on (WP 0048 00-47).</p>	<p>a. If no voltage is found at X67 pin 1, check circuit breaker F17 and continuity of wire A678 and A671 (WP 0048 00-46).</p> <p>b. Replace faulty circuit breaker (WP 0074 00).</p> <p>c. If no voltage (24V) is found at X67 pin 4, check continuity of wires 671, 671A, 674, A479, 479, and A17415, and test continuity of cold start system switch (WP 0048 00-47).</p> <p>d. Repair or replace damaged wires or connectors (WP 0113 00).</p> <p>e. Replace cold start system switch if faulty (WP 0073 00).</p> <p>a. If no voltage (24V) is found at X16 pin 2, check continuity of wires A17415A, 16011, A1508, 294, and A162A (WP 0048 00-47).</p> <p>b. Repair or replace damaged wires or connectors (WP 0113 00).</p>

Table 2. Electrical Troubleshooting Procedures (Non-Error Code).

MALFUNCTION	TEST OR INSPECTION	CORRECTIVE ACTION
<p>SERVICE LIGHTS</p> <p>1. Headlight(s) (High or Low Beam) Do Not Operate When Switch is Turned On.</p>	<p>1. Check position of blackout drive/marker light switch.</p> <p>2. Check circuit breakers F16, F18, F19, F20, and F21 for trip.</p> <p>3. Inspect headlights for damage or burned out lamps.</p> <p>4. Check headlight wiring harnesses and connectors for damage.</p> <p>5. Check voltage (24V) at X6 pin 2 with the headlight switch turned on.</p> <p>6. Check voltage (24V) at X19 pin 5 with the headlight switch turned on.</p>	<p>Place blackout drive/marker light switch in OFF position.</p> <p>a. Reset circuit breakers as required.</p> <p>b. If any breaker does not reset, use the wiring diagram to check circuit for short to ground (WP 0048 00-41). Replace any shorted or grounded harnesses (WP 0113 00).</p> <p>c. Replace damaged or faulty circuit breaker (WP 0074 00).</p> <p>a. Replace burned out lamps (WP 0084 00).</p> <p>b. Replace damaged headlight (WP 0084 00).</p> <p>Repair or replace damaged harnesses or connectors (see WP 0113 00).</p> <p>a. If no voltage (24V) is found, remove headlight switch and blackout drive/marker switch from the instrument panel and check for continuity.</p> <p>b. Replace damaged or faulty switch (WP 0073 00).</p> <p>c. If switches are good, use the wiring diagram to check the continuity of wires A79, 79, 63B, and 62 (WP 0048 00-41).</p> <p>d. Repair or replace damaged wires or connectors (WP 0113 00).</p> <p>a. If no voltage is found, check continuity of wire A62 (WP 0048 00-41).</p>

Table 2. Electrical Troubleshooting Procedures (Non-Error Code) - Continued.

MALFUNCTION	TEST OR INSPECTION	CORRECTIVE ACTION
<p>1. Headlight(s) (High or Low Beam) Do Not Operate When Switch is Turned On - Continued.</p>	<p>7. Check voltage (24V) at X19 pin 6 and 7 with the headlight switch turned on and operating the HI/LO beams.</p> <p>8. Check voltage (24V) at X11 pin 7 and X12 pin 6 with the headlight switch turned on and in LOW beam.</p> <p>9. Check voltage (24V) at X11 pin 8 and X12 pin 8 with the headlight switch turned on and in HIGH beam.</p>	<p>b. Repair or replace damaged wires or connectors (WP 0113 00).</p> <p>a. If no voltage is found, check continuity of wires 195, 196, and 197 (WP 0048 00-41).</p> <p>b. Repair or replace damaged wires or connectors (WP 0113 00).</p> <p>c. Check accessory control lever for damage and continuity (WP 0048 00-41).</p> <p>d. Replace damaged or faulty accessory control lever (WP 0234 00).</p> <p>a. If no voltage is found, use the wiring diagram to check circuit breakers F20 and F21 and the continuity of wires A196, A196A, A117, and A126 (WP 0048 00-41).</p> <p>b. Repair or replace damaged wires or connectors (WP 0113 00).</p> <p>c. Replace damaged or faulty circuit breaker (WP 0074 00).</p> <p>a. If no voltage is found, use the wiring diagram to check circuit breakers F18 and F19 and the continuity of wires A197, A197A, A118, and A128 (WP 0048 00-41).</p> <p>b. Repair or replace damaged wires or connectors (WP 0113 00).</p> <p>c. Replace damaged or faulty circuit breaker (WP 0074 00).</p>

Table 2. Electrical Troubleshooting Procedures (Non-Error Code) - Continued.

MALFUNCTION	TEST OR INSPECTION	CORRECTIVE ACTION
<p>1. Headlight(s) (High or Low Beam) Do Not Operate When Switch is Turned On - Continued.</p>	<p>10. Check continuity, using the wiring diagram, of the headlight wiring harnesses from X11 pin 7 and 8 to left headlight, and X12 pin 6 and 8 to the right headlight. USMC includes additional connectors to the headlights at the fender brackets (X11A and X12A).</p>	<p>Replace damaged or open harness or connectors (WP 0113 00).</p>
<p>2. Front/Rear Side Marker Light(s) or Taillight(s) Do Not Operate When Headlight Switch is Turned On.</p>	<p>1. Check position of blackout drive/marker light switch.</p> <p>2. Check circuit breakers F22 and F23 for trip.</p> <p>3. Inspect marker and taillights for damage or burned out lamps.</p> <p>4. Check marker and taillight wiring harnesses and connectors for damage.</p> <p>5. Check voltage (24V) at X6 pin 1 with the headlight switch turned on (headlights working).</p>	<p>Place blackout drive/marker light switch in OFF position.</p> <p>a. Reset circuit breakers as required.</p> <p>b. If any breaker does not reset, use the wiring diagram to check circuit for short to ground (WP 0048 00-41). Replace any shorted or grounded harnesses (WP 0113 00).</p> <p>c. Replace damaged or faulty circuit breaker (WP 0074 00).</p> <p>a. Replace burned out lamps (WP 0084 00).</p> <p>b. Replace damaged marker or taillights (WP 0084 00).</p> <p>Repair or replace damaged harnesses or connectors (WP 0113 00).</p> <p>a. If no voltage (24V) is found, remove headlight switch from the instrument panel and check for continuity.</p> <p>b. Replace damaged or faulty switch (WP 0073 00).</p>

Table 2. Electrical Troubleshooting Procedures (Non-Error Code) - Continued.

MALFUNCTION	TEST OR INSPECTION	CORRECTIVE ACTION
<p>2. Front/Rear Side Marker Light(s) or Taillight(s) Do Not Operate When Headlight Switch is Turned On - Continued.</p>	<p>6. Check voltage (24V) at F22 and F23 with the headlight switch on.</p> <p>7. Check voltage (24V) at X11 pin 1, X12 pin 7, X14 pin 2, X14 pin 9, X15 pin 2, and X15 pin 7 with the headlight switch turned on.</p> <p>8. Check continuity, using the wiring diagram, of the marker and taillight wiring harnesses from X11 pin 1 to left front marker, X12 pin 7 to the right front marker, X15 pin 2 to the left rear marker, X14 pin 2 to the right rear marker, X14 pin 9 to the right taillight, and X15 pin 7 to the left taillight. USMC includes additional connectors to the marker and taillights at the fender brackets (X11A, X12A, X14A, and X15A).</p>	<p>c. If switch is good, use the wiring diagram to check the continuity of wires 61 and A61 (WP 0048 00-41).</p> <p>d. Repair or replace damaged wires or connectors (WP 0113 00).</p> <p>Replace damaged or faulty circuit breaker (WP 0074 00).</p> <p>a. If no voltage is found at any pin, check continuity, using the wiring diagram, of wires A149, A157, A149B, A149A, A157A, and A157B (WP 0048 00-41).</p> <p>b. Repair or replace damaged wires or connectors (WP 0113 00).</p> <p>Replace damaged or open harness or connectors (WP 0113 00).</p>
<p>3. Stoplight(s) Do Not Operate When Brake Pedal is Pressed.</p>	<p>1. Check position of blackout drive/marker light switch.</p> <p>2. Check circuit breaker F10 for trip.</p>	<p>Place blackout drive/marker light switch in OFF position.</p> <p>a. Reset circuit breaker as required.</p>

Table 2. Electrical Troubleshooting Procedures (Non-Error Code) - Continued.

MALFUNCTION	TEST OR INSPECTION	CORRECTIVE ACTION
<p>3. Stoplight(s) Do Not Operate When Brake Pedal is Pressed - Continued.</p>	<p>3. Inspect stoplights for damage or burned out lamps.</p> <p>4. Check stoplight wiring harnesses and connectors for damage.</p> <p>5. Check voltage (24V) at X26 pin 2 and 3 with the ignition on and the brake pedal depressed. (Ensure the hydraulic brake pressure is built up.)</p> <p>6. Check voltage (24V) at XK13 pin 6 and 9 with the ignition on and the brake pedal depressed. (Ensure the hydraulic brake pressure is built up.)</p>	<p>b. If breaker does not reset, use the wiring diagram to check circuit for short to ground (WP 0048 00-36). Replace any shorted or grounded harnesses (WP 0113 00).</p> <p>c. Replace damaged or faulty circuit breaker (WP 0074 00).</p> <p>a. Replace burned out lamps (WP 0098 00).</p> <p>b. Replace damaged stoplights (WP 0098 00).</p> <p>Repair or replace damaged harnesses or connectors (WP 0113 00).</p> <p>a. If no voltage (24V) is found, remove the kick panel in front of the steering column and check brake light switch 216 for continuity while depressing the brake pedal (WP 0098 00).</p> <p>b. Replace damaged or faulty switch (WP 0098 00).</p> <p>c. If switch is good, use the wiring diagram to check the continuity of wires 262 and 263 (WP 0048 00-36).</p> <p>d. Repair or replace damaged wires or connectors (WP 0113 00).</p> <p>a. If no voltage (24V) is found, remove relay 3010 and test (WP 0113 00).</p> <p>b. Replace damaged or faulty relay (WP 0074 00).</p>

Table 2. Electrical Troubleshooting Procedures (Non-Error Code) - Continued.

MALFUNCTION	TEST OR INSPECTION	CORRECTIVE ACTION
<p>3. Stoplight(s) Do Not Operate When Brake Pedal is Pressed - Continued.</p>	<p>7. With the 3010 relay removed, check continuity between XK13 pin 9 and 3010 terminal 30, and XK 13 pin 6 and 3010 terminal 87a.</p> <p>8a. Check voltage (24V) at XK14 pin 4 and 7 with the ignition on and the brake pedal depressed. (Ensure the hydraulic brake pressure is built up).</p> <p>8b. Check continuity of wires A036 and A263 (WP 0048 00-42 and WP 0048 00-36).</p> <p>9. With the 3015R relay removed, check continuity between XK14 pin 7 and 3015R terminal 30, and XK14 pin 4 and 3015R terminal 87a.</p> <p>10a. Check voltage (24V) at XK15 pin 4 and 7 with the ignition on and the brake pedal depressed. (Ensure the hydraulic brake pressure is built up.)</p> <p>10b. Check continuity of wires A036 and A263 (WP 0048 00-42 and WP 0048 00-36).</p>	<p>a. If no continuity is found, remove relay board and inspect the underside of the board.</p> <p>b. Replace damaged or faulty relay board (WP 0074 00).</p> <p>a. If no voltage (24V) is found, remove relay 3015R and test (WP 0113 00).</p> <p>b. Replace damaged or faulty relay (WP 0074 00).</p> <p>c. Repair or replace damaged wires or connectors (WP 0113 00).</p> <p>a. If no continuity is found, remove relay board and inspect the underside of the board.</p> <p>b. Replace damaged or faulty relay board (WP 0074 00).</p> <p>a. If no voltage (24V) is found, remove relay 3015L and test (WP 0113 00).</p> <p>b. Replace damaged or faulty relay (WP 0074 00).</p> <p>c. Repair or replace damaged wires or connectors (WP 0113 00).</p>

Table 2. Electrical Troubleshooting Procedures (Non-Error Code) - Continued.

MALFUNCTION	TEST OR INSPECTION	CORRECTIVE ACTION
<p>3. Stoplight(s) Do Not Operate When Brake Pedal is Pressed - Continued.</p>	<p>10c. With the 3015L relay removed, check continuity between XK15 pin 7 and 3015L terminal 30, and XK15 pin 4 and 3015L terminal 87a.</p> <p>11. Check continuity, using the wiring diagram, of the stoplight wiring harnesses from XK14 pin 7 to the right stoplight and XK15 pin 7 to the left stoplight (WP 0048 00-42). USMC includes additional connectors to the stoplights at the fender brackets (X14A and X15A).</p>	<p>d. If no continuity is found, remove relay board and inspect the underside of the board.</p> <p>e. Replace damaged or faulty relay board (WP 0074 00).</p> <p>Replace damaged or open harness or connectors (WP 0113 00).</p>
<p>4. Turn Signals or Emergency Flashers are Not Working.</p>	<p>1. Check position of blackout drive/marker light switch.</p> <p>2. Check circuit breakers F2 and F6 for trip.</p> <p>3. Inspect signal lights for damage or burned out lamps.</p> <p>4. Check signal light wiring harnesses and connectors for damage.</p> <p>5. Check voltage (24V) at X19 pin 1, 2, and 3 while operating the turn signal lever. There should be voltage (24V) at pin 2 when signaling left and at pin 3 for right.</p>	<p>Place blackout drive/marker light switch in OFF position.</p> <p>a. Reset circuit breaker as required.</p> <p>b. If breaker does not reset, use the wiring diagram to check circuit for short to ground (WP 0048 00-42). Replace any shorted or grounded harnesses (WP 0113 00).</p> <p>a. Replace burned out lamps (WP 0086 00).</p> <p>b. Replace damaged signal lights (WP 0086 00).</p> <p>Repair or replace damaged harnesses or connectors (WP 0113 00).</p> <p>a. If no voltage (24V) is found at X19 pin 1, check circuit breaker F6 and wire A191 (WP 0048 00-42).</p>

Table 2. Electrical Troubleshooting Procedures (Non-Error Code) - Continued.

MALFUNCTION	TEST OR INSPECTION	CORRECTIVE ACTION
<p>4. Turn Signals or Emergency Flashers are Not Working - Continued.</p>	<p>6. Check voltage (24V) at XK14 pin 8 and XK15 pin 8 while operating the turn signal lever. There should be voltage (24V) at pin XK15 pin 8 when signaling left and at XK14 pin 8 for right.</p> <p>7. Check voltage (24V) at XK1 pin 5 and pin 1 while operating the turn signals. There should be constant voltage at pin 5 and flashing voltage at pin 1.</p> <p>8. Check continuity, with 323 flasher relay removed, between XK1 pin 5 and 323 terminal 49, and XK1 pin 1 and 323 terminal 49a, and XK1 pin 2 and 323 terminal 31.</p>	<p>b. If no voltage (24V) is found at X19 pin 2 or 3 while operating the signal lever; check accessory control lever for damage and continuity and check continuity of wires 191, 192, and 193 (WP 0048 00-42).</p> <p>c. Replace damaged or faulty accessory control lever (WP 0234 00).</p> <p>d. Repair or replace damaged wires or connectors (WP 0113 00).</p> <p>a. If no voltage (24V) is found, check continuity of wires A192 and A193 (WP 0048 00-42).</p> <p>b. Repair or replace damaged wires or connectors (WP 0113 00).</p> <p>a. If no voltage is found at XK1 pin 5, check blackout drive/ marker light switch and circuit from circuit breaker F2 (WP 0048 00-40).</p> <p>b. If no flashing voltage found at XK1 pin 1, replace damaged or faulty 323 flasher relay (WP 0074 00).</p> <p>a. If no continuity found, remove relay board and inspect the underside of the board.</p> <p>b. Replace damaged or faulty relay board (WP 0074 00).</p>

Table 2. Electrical Troubleshooting Procedures (Non-Error Code) - Continued.

MALFUNCTION	TEST OR INSPECTION	CORRECTIVE ACTION
<p>4. Turn Signals or Emergency Flashers are Not Working - Continued.</p>	<p>9. Check voltage (24V) at XK14 pin 3 and XK15 pin 3 while operating the turn signals. There should be flashing voltage at XK14 pin 3 for signaling right and a XK15 pin 3 for left.</p> <p>10. Check voltage (24V) at XK14 pin 7 and XK15 pin 7 while operating the turn signals. There should be flashing voltage at XK14 pin 7 for signaling right and at XK15 pin 7 for left.</p> <p>11. Check continuity, using the wiring diagram, of the signal wiring harnesses from XK14 pin 7 to the right rear and XK14 pin 3 for the right front, and XK15 pin 7 to the left rear and XK 15 pin 3 for the left front (WP 0048 00-42).</p> <p>12. For emergency flashers check voltage (24V) at X6 pin 4, 5, and 6 with the emergency flasher switch depressed. USMC includes additional connectors to the marker and taillights at the fender brackets (X11A, X12A, X14A, and X15A).</p>	<p>a. If no voltage (24V) is found, remove relays 310 and 311 and test (WP 0113 00).</p> <p>b. Replace damaged or faulty relay (WP 0074 00).</p> <p>a. If no voltage (24V) is found, remove relays 3015L and 301SR and test (WP 0113 00).</p> <p>b. Replace damaged or faulty relay (WP 0074 00).</p> <p>Replace damaged or open harness or connectors (WP 0113 00).</p> <p>a. If no voltage (24V) is found at any one pin, remove emergency flasher switch and check for damage and continuity (WP 0073 00).</p> <p>b. Replace damaged or faulty switch (WP 0073 00).</p> <p>c. Check continuity, using the wiring diagram, of wires 64, 65, and 66 (WP 0048 00-42).</p>
<p>BLACKOUT DRIVE AND MARKER LIGHTS</p> <p>5. Blackout Drive and Marker Lights Do Not Operate When Switch is Turned On.</p>	<p>1. Check position of blackout drive/marker light switch.</p> <p>2. Check circuit breakers F24 and F25 for trip.</p>	<p>Place blackout drive/marker light switch in ON position.</p> <p>a. Reset circuit breakers as required.</p>

Table 2. Electrical Troubleshooting Procedures (Non-Error Code) - Continued.

MALFUNCTION	TEST OR INSPECTION	CORRECTIVE ACTION
<p>5. Blackout Drive and Marker Lights Do Not Operate When Switch is Turned On - Continued.</p>	<p>3. Inspect blackout drive and marker lights for damage or burned out lamps.</p> <p>4. Check blackout drive and marker light wiring harnesses and connectors for damage.</p> <p>5. Check voltage (24V) at X7 pin 9 and 6 with the blackout drive marker light switch turned on.</p> <p>6. Check voltage (24V) at X11 pin 3, X11 pin 9, X12 pin 1, X14 pin 1, and X15 pin 1 with the blackout drive marker light switch turned on.</p>	<p>b. If any breaker does not reset, use the wiring diagram to check circuit for short to ground (WP 0048 00-41). Replace any shorted or grounded harnesses (WP 0113 00).</p> <p>c. Replace damaged or faulty circuit breaker (WP 0074 00).</p> <p>a. Replace burned out lamps (WP 0087 00).</p> <p>b. Replace damaged blackout lights (WP 0087 00).</p> <p>Repair or replace damaged harnesses or connectors (WP 0113 00).</p> <p>a. If no voltage (24V) is found, remove blackout drive/marker switch from the instrument panel and check for continuity.</p> <p>b. Replace damaged or faulty switch (WP 0073 00).</p> <p>c. If switch is good, use the wiring diagram to check the continuity of the wires A79, 79, 76 and A76, (WP 0048 00-43).</p> <p>d. Repair or replace damaged wires or connectors (WP 0113 00).</p> <p>a. If no voltage found, check continuity of wires A113, A153, A119, A121, and A141 (WP 0048 00-43).</p> <p>b. Repair or replace damaged wires or connectors (WP 0113 00).</p>

Table 2. Electrical Troubleshooting Procedures (Non-Error Code) - Continued.

MALFUNCTION	TEST OR INSPECTION	CORRECTIVE ACTION
<p>5. Blackout Drive and Marker Lights Do Not Operate When Switch is Turned On - Continued.</p>	<p>7. Check continuity, using the wiring diagram, of the blackout drive marker light wiring harnesses from X11 pin 3 to left front blackout position light, X12 pin 1 to right front blackout position light, X14 pin 1 to right blackout taillight, X15 pin 3 to the left blackout taillight, and X11 pin 9 to blackout headlight. USMC includes additional connectors to the blackout lights at the fender brackets (X11A, X12A, X14A, and X15A).</p>	<p>Replace damaged or open harness or connectors (WP 0113 00).</p>
<p>6. Blackout Stoplights Not Working.</p>	<p>1. Check the operation of the normal stoplights.</p> <p>2. Check position of blackout drive/marker light switch.</p> <p>3. Inspect stoplights for damage or burned out lamps.</p> <p>4. Check blackout stoplight wiring harnesses and connectors for damage.</p> <p>5. Check voltage (24V) at XK13 pin 3 with the ignition on and the brake pedal depressed. (Ensure the hydraulic brake pressure is built up).</p>	<p>If stoplights are not working, perform troubleshooting procedure for “<i>Stoplight(s) Do Not Operate When Brake Pedal is Pressed</i>” in this work package.</p> <p>Place blackout drive/marker light switch in ON position.</p> <p>a. Replace burned out lamps (WP 0087 00).</p> <p>b. Replace damaged blackout stoplights (WP 0087 00).</p> <p>Repair or replace damaged harnesses or connectors (WP 0113 00).</p> <p>a. If no voltage (24V) is found, remove relay 3010 and test (WP 0113 00).</p> <p>b. Replace damaged or faulty relay (WP 0074 00).</p>

Table 2. Electrical Troubleshooting Procedures (Non-Error Code) - Continued.

MALFUNCTION	TEST OR INSPECTION	CORRECTIVE ACTION
<p>6. Blackout Stoplights Not Working - Continued.</p> <p>HORN, BACKUP ALARM, AND BACKUP LIGHTS</p> <p>7. Horn Will Not Sound When Button is Pressed.</p>	<p>6. Check continuity, using the wiring diagram, of the blackout drive marker light wiring harnesses from XK13 pin 3 to right and left blackout stoplights (WP 0048 00-44). USMC includes additional connectors to the blackout stoplights at the fender brackets (X14A and X15A).</p> <p>1. Check position of blackout drive/marker light switch.</p> <p>2. Check circuit breaker F9 for trip.</p> <p>3. Inspect horn, connectors, and wiring for damage.</p> <p>4. Check voltage (24V) at X20 pin 1 and 2 with the horn switch depressed.</p>	<p>Replace damaged or open harness or connectors (WP 0113 00).</p> <p>Place blackout drive/marker light switch in OFF position.</p> <p>Reset circuit breaker as required.</p> <p>a. Test horn using 24V source.</p> <p>b. Replace damaged horn (WP 0105 00).</p> <p>c. Repair or replace damaged harnesses or connectors (WP 0113 00).</p> <p>a. If no voltage (24V) is found at X20 pin 1, check continuity of wire A201 (WP 0048 00-38).</p> <p>b. If no voltage (24V) is found at X20 pin 2, check accessory control lever for damage and continuity (WP 0048 00-40).</p> <p>c. Replace damaged or faulty accessory control lever (WP 0234 00).</p>

Table 2. Electrical Troubleshooting Procedures (Non-Error Code) - Continued.

MALFUNCTION	TEST OR INSPECTION	CORRECTIVE ACTION
<p>7. Horn Will Not Sound When Button is Pressed - Continued.</p>	<p>5. Check voltage (24V) at X13 pin 9 with the horn switch depressed.</p> <p>6. Unplug the horn and check for voltage (24V) between the two pins of the harness with the horn switch depressed.</p>	<p>a. Remove relay 3016 and test (WP 0113 00).</p> <p>b. Replace damaged or faulty relay (WP 0074 00).</p> <p>c. Check continuity of wires 202, A202, and A139 (WP 0048 00-40).</p> <p>d. Repair or replace damaged wires or connectors (WP 0113 00).</p> <p>a. If no voltage (24V) is found, check continuity of wires 139 and 135B (WP 0048 00-40).</p> <p>b. Repair or replace damaged wires or connectors (WP 0113 00).</p>
<p>8. Backup Lights/Alarm Does Not Operate When Vehicle Placed in Reverse.</p>	<p>1. Check position of blackout drive/marker light switch.</p> <p>2. Check circuit breaker F10 for trip.</p> <p>3. Inspect backup lights and alarm for damage or burned out lamps.</p>	<p>Place blackout drive/marker light switch in OFF position.</p> <p>a. Reset circuit breaker as required.</p> <p>b. If breaker does not reset, use the wiring diagram to check circuit for short to ground (WP 0048 00-45). Replace any shorted or grounded harnesses (WP 0113 00).</p> <p>c. Replace damaged or faulty circuit breaker (WP 0074 00).</p> <p>a. Replace burned out lamps (WP 0085 00).</p> <p>b. Replace damaged backup lights (WP 0085 00).</p> <p>c. Test backup alarm with 24V source.</p>

Table 2. Electrical Troubleshooting Procedures (Non-Error Code) - Continued.

MALFUNCTION	TEST OR INSPECTION	CORRECTIVE ACTION
<p>8. Backup Lights/Alarm Does Not Operate When Vehicle Placed in Reverse - Continued.</p>	<p>4. Check backup lights/alarm wiring harnesses and connectors for damage.</p> <p>5. Check voltage (24V) at XK5 pin 1 and 7 with the ignition on and the transmission control lever placed in Reverse.</p> <p>6. Check voltage (24V) at XK13 pin 4 and 7 with the ignition on and the transmission control lever placed in Reverse.</p> <p>7. Check voltage (24V) at XK5 pin 5 with the ignition on while switching transmission control lever between Neutral and Reverse. There should be voltage (24V) when in Neutral and no voltage (OV) when in Reverse.</p>	<p>d. Replace damaged backup alarm (WP 0106 00).</p> <p>Repair or replace damaged harnesses or connectors (WP 0113 00).</p> <p>a. If no voltage (24V) is found at XK5 pin 1, remove relay 305 and test (WP 0113 00).</p> <p>b. Replace damaged or faulty relay (WP 0074 00).</p> <p>c. If no voltage (24V) is found at XK5 pin 7, check continuity of wire A57 (WP 0048 00-45).</p> <p>d. Repair or replace damaged wires or connectors (WP 0113 00).</p> <p>a. If no voltage (24V) is found at XK13 pin 4, remove relay 3011 and test (WP 0113 00).</p> <p>b. Replace damaged or faulty relay (WP 0074 00).</p> <p>c. If no voltage (24V) is found at XK13 pin 7, check continuity of wire A51 (WP 0048 00-45).</p> <p>d. Repair or replace damaged wires or connectors (WP 0113 00).</p> <p>a. If voltage does not change, remove relay 305 and test (WP 0113 00).</p>

Table 2. Electrical Troubleshooting Procedures (Non-Error Code) - Continued.

MALFUNCTION	TEST OR INSPECTION	CORRECTIVE ACTION
<p>8. Backup Lights/Alarm Does Not Operate When Vehicle Placed in Reverse - Continued.</p>	<p>8. Check continuity, using the wiring diagram, of the backup light/alarm wiring harnesses from X14 and X15 to the backup lights and alarm (WP 0048 00-45). USMC includes additional connectors to the backup lights/alarm at the fender brackets (X14A and X15A).</p>	<p>b. Check continuity of wires A55 and 293 (WP 0048 00-45).</p> <p>c. Check continuity of wires 16010 and A17710 (WP 0048 00-12).</p> <p>d. Repair or replace damaged wires or connectors (WP 0113 00).</p> <p>e. Replace ECU (793).</p> <p>Repair or replace damaged harnesses or connectors (WP 0113 00).</p>
<p>BOOM AND TOPHANDLER WORK LIGHTS</p>		
<p>9. Boom Work Light(s) Do Not Operate When Switch is Turned On.</p>	<p>1. Check position of blackout drive/marker light switch.</p> <p>2. Check circuit breaker F12 for trip.</p> <p>3. Inspect boom work lights for damage or burned out lamps.</p>	<p>Place blackout drive/marker light switch in OFF position.</p> <p>a. Reset circuit breaker as required.</p> <p>b. If breaker does not reset, use the wiring diagram to check circuit for short to ground (WP 0048 00-46). Replace any shorted or grounded harnesses (WP 0113 00).</p> <p>c. Replace damaged or faulty circuit breaker (WP 0074 00).</p> <p>a. Replace burned out lamps (WP 0085 00).</p> <p>b. Replace damaged lights (WP 0085 00).</p>

Table 2. Electrical Troubleshooting Procedures (Non-Error Code) - Continued.

MALFUNCTION	TEST OR INSPECTION	CORRECTIVE ACTION
<p>9. Boom Work Light(s) Do Not Operate When Switch is Turned On - Continued.</p>	<p>4. Check boom work lights wiring harnesses and connectors for damage.</p> <p>5. Check voltage (24V) at X7 pin 1 and 3 with the boom work light switch turned on.</p> <p>6. Remove relay 3013 and test (WP 0113 00).</p> <p>7. Check voltage (24V) at XK11 pin 6, X31 pin 1, X151 pin 1, X157 pin 5, and X169 pin 5 with the boom work light switch turned on.</p> <p>8. Disconnect two GY wires from X169 pin 5. Check resistance between each wire and ground. (Ensure the boom work light lamps are not burned out.)</p>	<p>Repair or replace damaged harnesses or connectors (WP 0113 00).</p> <p>a. If no voltage (24V) is found, remove boom work light switch from the instrument panel and check for continuity.</p> <p>b. Replace damaged or faulty switch (WP 0073 00).</p> <p>c. If switch is good, use the wiring diagrams to check the continuity of wires A73, 73, 71, and A71 (WP 0048 00-46).</p> <p>d. Repair or replace damaged wires or connectors (WP 0113 00).</p> <p>Replace damaged or faulty relay (WP 0074 00).</p> <p>a. If no voltage is found, check continuity of wires A311, 311, A1511, and YE (WP 0048 00-46).</p> <p>b. Repair or replace damaged wires or connectors (WP 0113 00).</p> <p>a. If no resistance is found on either wire, replace boom work light wiring harness (WP 0113 00).</p> <p>b. Repair or replace damaged wires or connectors (WP 0113 00).</p>

Table 2. Electrical Troubleshooting Procedures (Non-Error Code) - Continued.

MALFUNCTION	TEST OR INSPECTION	CORRECTIVE ACTION
<p>10. Tophandler Work Light(s) Do Not Operate When Switch is Turned On.</p>	<ol style="list-style-type: none"> 1. Check position of blackout drive/marker light switch. 2. Check circuit breakers F17 in cab distribution box and F43, (3), located in the tophandler junction box, for trip. 3. Inspect tophandler work lights for damage or burned out lamps. 4. Check tophandler work lights wiring harnesses and connectors for damage. 5. Check work light switch. Enter "EXTRA FUNC" 5(13) in the diagnostic menu. Press the tophandler work light switch. 6. Check voltage (24V) at X67 pin 8 and 9 with the tophandler work light switch turned on. 	<p>Place blackout drive/marker light switch in OFF position.</p> <ol style="list-style-type: none"> a. Reset circuit breakers as required. b. If breaker does not reset, use the wiring diagram to check circuit for short to ground (WP 0048 00-46) and WP 0048 00-23). Replace any shorted or grounded harnesses (WP 0113 00). c. Replace damaged or faulty circuit breaker (WP 0074 00). a. Replace burned out lamps (WP 0085 00). b. Replace damaged tophandler work lights (WP 0085 00). <p>Repair or replace damaged harnesses or connectors (WP 0113 00).</p> <p>Should have a "1" next to "WORK LIGHT ATTACH".</p> <ol style="list-style-type: none"> a. If there is a "0", continue with step 6. b. If there is a "1", continue with step 8. a. If no voltage (24V) is found, remove tophandler work light switch from the instrument panel and check for continuity. b. Replace damaged or faulty switch (WP 0073 00).

Table 2. Electrical Troubleshooting Procedures (Non-Error Code) - Continued.

MALFUNCTION	TEST OR INSPECTION	CORRECTIVE ACTION
<p>10. Tophandler Work Light(s) Do Not Operate When Switch is Turned On - Continued.</p>	<p>7. Check voltage (24V) at X46 pin 6, X174 pin 11, and ECU (792) pin 102 with the tophandler work light switch turned on.</p> <p>8. Check relay. Remove relay 3017 and test (WP 0113 00).</p> <p>9. Check voltage. Remove relay 3017 and check voltage (24V) at 3017 socket pin 30.</p> <p>10. Check voltage. Remove relay 3017 and check voltage (24V) at 3017 socket pin 86.</p> <p>11. Unplug X194. Check resistance between pin A and B, then C and D on the loose part of X194. (Ensure the tophandler work light lamps are not burned out).</p>	<p>c. If switch is good, use the wiring diagram to check the continuity of the wires A678, 678, and 679 (WP 0048 00-46).</p> <p>d. Repair or replace damaged wires or connectors (WP 0113 00).</p> <p>a. If no voltage is found, check continuity of wires A466, 466, and A17411 (WP 0048 00-46 and WP 0048 00-18).</p> <p>b. Repair or replace damaged wires or connectors (WP 0113 00).</p> <p>Replace damaged or faulty relay (WP 0074 00 00).</p> <p>a. If no voltage (24V) is found, check continuity of wires A513 and A1861B (WP 0048 00-28 and WP 0048 00-23).</p> <p>b. Repair or replace damaged wires or connectors (WP 0113 00).</p> <p>a. If no voltage (24V) is found, check continuity of wire A3018A (WP 0048 00-28).</p> <p>b. Repair or replace damaged wires or connectors (WP 0113 00).</p> <p>a. If there is no resistance on either pin check, replace X194 harness to tophandler work lights (WP 0113 00).</p>

Table 2. Electrical Troubleshooting Procedures (Non-Error Code) - Continued.

MALFUNCTION	TEST OR INSPECTION	CORRECTIVE ACTION
<p>10. Tophandler Work Light(s) Do Not Operate When Switch is Turned On - Continued.</p>	<p>12. Check continuity of wires A194A, A194B, A194C, and A194D (WP 0048 00-28).</p> <p>13. Unplug ECU (791) connector 2. Check voltage (24V) at pin 14 with the ignition on.</p>	<p>b. Repair or replace damaged wires or connectors (WP 0113 00).</p> <p>Repair or replace damaged wires or connectors (WP 0113 00).</p> <p>a. If no voltage (24V), check continuity of wire A18052B (WP 0048 00-28).</p> <p>b. Repair or replace damaged wires or connectors (WP 0113 00).</p> <p>c. Replace ECU (791) (WP 0080 00).</p>
<p>10. BOOM INFRARED (IR) WORK LIGHTS</p>		
<p>11. IR Work Light(s) Do Not Operate When Switch is Turned On.</p>	<p>1. Check position of blackout drive/marker light switch.</p> <p>2. Check circuit breaker F2 for trip.</p> <p>3. Inspect IR work lights for damage or burned out lamps. (A digital camera can be used to check the operation of IR lights.)</p> <p>4. Check IR work light wiring harnesses and connectors for damage.</p>	<p>Place blackout drive/marker light switch in ON position.</p> <p>a. Reset circuit breakers as required.</p> <p>b. If any breaker does not reset, use the wiring diagram to check circuit for short to ground (WP 0048 00-40). Replace any shorted or grounded harnesses (WP 0113 00).</p> <p>c. Replace damaged or faulty circuit breaker (WP 0074 00).</p> <p>a. Replace burned out lamps (WP 0090 00).</p> <p>b. Replace damaged IR light (WP 0090 00).</p> <p>Repair or replace damaged harnesses or connectors (WP 0113 00).</p>

Table 2. Electrical Troubleshooting Procedures (Non-Error Code) - Continued.

MALFUNCTION	TEST OR INSPECTION	CORRECTIVE ACTION
<p>11. IR Work Light(s) Do Not Operate When Switch is Turned On - Continued.</p>	<p>5. Check voltage (24V) at X6 pin 8 and X7 pin 7 with the blackout drive marker light switch and IR work light switch turned on.</p> <p>6. Check voltage (24V) at X15 pin 5, X11 pin 5, X31 pin 3, X151 pin 3, X157 pin 7, and X169 pin 7 with the blackout drive marker light switch and IR work light switch turned on.</p> <p>7. Check continuity, using the wiring diagram, of the IR work light wiring harnesses from X16 pin 7 to left and right boom IR work lights, X15 pin 5 to left rear IR work light, and X11 pin 5 to left front IR work light (WP 0048 00-43, WP 0048 00-45, and WP 0048 00-46). USMC includes additional connectors to the IR work lights at the fender brackets (X11A and X15A).</p>	<p>a. If no voltage (24V) is found, remove IR work light and blackout drive/marker switch from the instrument panel and check for continuity.</p> <p>b. Replace damaged or faulty switch (WP 0073 00).</p> <p>c. If switch is good, use the wiring diagram to check the continuity of wires A77, 77, 1211, and 68 (WP 0048 00-40).</p> <p>d. Repair or replace damaged wires or connectors (WP 0113 00).</p> <p>a. If no voltage found, check continuity of wires A155, A115, A313, 313, A1513, and WH (WP 0048 00-40, WP 0048 00-43, WP 0048 00-45, and WP 0048 00-46).</p> <p>b. Repair or replace damaged wires or connectors (WP 0113 00).</p> <p>Replace damaged or open harness or connectors (WP 0113 00).</p>

Table 2. Electrical Troubleshooting Procedures (Non-Error Code) - Continued.

MALFUNCTION	TEST OR INSPECTION	CORRECTIVE ACTION
<p>WINDSHIELD WIPER MOTORS AND WASHER</p> <p>12.Front Windshield Wiper Motor Not Working.</p>	<p>1. Check circuit breaker F6 and F9 for trip.</p> <p>2. Inspect wiper arm for binding or damage.</p> <p>3. Check voltage (24V) at X20 pin 1, 4, and 5 with the ignition on while operating the front wiper control switch. There should be voltage (24V) at pin 4 for intermittent wiper and at pin 5 for continuous wiper.</p>	<p>a. Reset circuit breaker as required.</p> <p>b. If breaker does not reset, use the wiring diagram to check circuit for short to ground (WP 0048 00-36). Replace any shorted or grounded harnesses (WP 0113 00).</p> <p>c. Replace damaged or faulty circuit breaker (WP 0074 00).</p> <p>a. Correct binding wiper arm (WP 0158 00).</p> <p>b. Replace damage wiper arm (WP 0158 00).</p> <p>a. If no voltage (24V) is found at X20 pin 1, check circuit breaker F9 and continuity of wire A201 (WP 0048 00-38).</p> <p>b. If no voltage (24V) is found at X20 pin 4 or 5 while operating the front wiper control switch, check accessory control lever for damage and continuity and check continuity of wires 201, 204, and 205 (WP 0048 00-38).</p> <p>c. Replace damaged or faulty accessory control lever (WP 0234 00).</p> <p>d. Repair or replace damaged wires or connectors (WP 0113 00).</p>

Table 2. Electrical Troubleshooting Procedures (Non-Error Code) - Continued.

MALFUNCTION	TEST OR INSPECTION	CORRECTIVE ACTION
<p>12.Front Windshield Wiper Motor Not Working - Continued.</p>	<p>4a. Check relay. Remove relay 316 and test (WP 0113 00).</p> <p>4b. With the 316 relay removed, check continuity between XK2 pin 9 and terminal 30, XK2 pin 3 and terminal 87, XK2 pin 6 and terminal 87a, XK2 pin 8 and terminal 86, and XK3 pin 5 and terminal 85.</p> <p>5. Check voltage (24V) at X27 pin 6 and 7 with the ignition on while operating the front wiper control switch to the CONTINUOUS position.</p> <p>6. Inspect intermittent relay 321-1 for damage. Disconnect relay plug and check voltage (24) at pin 3 and 5 with the ignition on while operating the front wiper control switch to the INTERMITTENT position.</p>	<p>a. Replace damaged or open harness or connectors (WP 0113 00).</p> <p>b. If no continuity is found, remove relay board and inspect the underside of the board.</p> <p>c. Replace damaged or faulty relay board (WP 0074 00).</p> <p>a. If no voltage (24V) is found at X27 pin 6, check circuit breaker F6 and continuity of wires A276, A66, and A191 (WP 0048 00-38, and WP 0048 00-42).</p> <p>b. If no voltage (24V) is found at X27 pin 7 while operating the front wiper control switch to the CONTINUOUS position, check continuity of wires A23 and A29 (WP 0048 00-38).</p> <p>c. Repair or replace damaged wires or connectors (WP 0113 00).</p> <p>a. If no voltage (24V) is found at 321-1 pin 3 or 5, check continuity of wires A201A, A204, A26, and A278 (WP 0048 00-38).</p> <p>b. Replace damaged or faulty relay (WP 0074 00).</p> <p>c. Repair or replace damaged wires or connectors (WP 0113 00).</p>

Table 2. Electrical Troubleshooting Procedures (Non-Error Code) - Continued.

MALFUNCTION	TEST OR INSPECTION	CORRECTIVE ACTION
<p>12. Front Windshield Wiper Motor Not Working - Continued.</p>	<p>7. Remove front windshield wiper motor from front of cab (WP 0157 00). Inspect wiper motor for damage and wiring connections. Unplug wiper motor and check voltage (24V) at XS4 pin 3 and 4 with the ignition on while operating the front wiper control switch to the CONTINUOUS position.</p>	<p>a. If no voltage (24V) is found at XS4 pin 3 or 4, check continuity of wires 276, 277, and 278 (WP 0048 00-38). b. Check ground connection at wiper motor. Check continuity of wires 279, A279, and ground connection at 37-1 (WP 0048 00-38). c. Repair or replace damaged wires or connectors (WP 0113 00). d. Replace damaged or faulty front wiper motor (WP 0158 00).</p>
<p>13. Rear Windshield Wiper Motor Not Working.</p>	<p>1. Check circuit breaker F15 for trip.</p> <p>2. Inspect wiper arm for binding or damage.</p> <p>3. Check voltage (24V) at X9 pin 1, 2, and 3 with the ignition on while operating the rear wiper control switch. There should be voltage (24V) at pin 1 (intermittent voltage) and 2 for intermittent wiper.</p>	<p>a. Reset circuit breaker as required. b. If breaker does not reset, use the wiring diagram to check circuit for short to ground (WP 0048 00-36). Replace any shorted or grounded harnesses (WP 0113 00). c. Replace damaged or faulty circuit breaker (WP 0074 00). a. Correct binding wiper arm (WP 0158 00). b. Replace damaged wiper arm (WP 0158 00). a. If no voltage (24V) is found at X9 pin 3, check circuit breaker F15 and continuity of wires A89 and A89A (WP 0048 00-38).</p>

Table 2. Electrical Troubleshooting Procedures (Non-Error Code) - Continued.

MALFUNCTION	TEST OR INSPECTION	CORRECTIVE ACTION
<p>13.Rear Windshield Wiper Motor Not Working - Continued.</p>	<p>4. Inspect intermittent relay 321-2 for damage. Disconnect relay plug and check voltage (24) at pin 3 and 5 with the ignition on while operating the rear wiper control switch to the INTERMITTENT position.</p> <p>5. Remove the cover to gain access to the rear windshield wiper motor at rear of cab (WP 0158 00). Inspect wiper motor for damage and wiring connections. Unplug wiper motor and check voltage (24V) at XS5 pin 2 and 3 with the ignition on while operating the rear wiper control switch to the CONTINUOUS position.</p>	<p>b. If no voltage (24V) is found at X9 pin 1 or 2 while operating the rear wiper control switch, check rear wiper switch for damage and continuity and check continuity of wires 91, 92, 93, 94, and A94 (WP 0048 00-38).</p> <p>c. Replace damaged or faulty rear wiper switch (WP 0073 00).</p> <p>d. Repair or replace damaged wires or connectors (WP 0113 00).</p> <p>a. If no voltage (24V) is found at 321-2 pin 3 or 5, check continuity of wires A91, A92, A93, A138, A136, A246, and A84B (WP 0048 00-38).</p> <p>b. Replace damaged or faulty relay (WP 0074 00).</p> <p>c. Repair or replace damaged wires or connectors (WP 0113 00).</p> <p>a. If no voltage (24V) is found at XS5 pin 2 or 3, check continuity of wires 136, 137, and 138 (WP 0048 00-38).</p> <p>b. Check ground connection at wiper motor. Check continuity of wire 135 and ground connection at 37-1 (WP 0048 00-38).</p> <p>c. Repair or replace damaged wires or connectors (WP 0113 00).</p> <p>d. Replace damaged or faulty rear wiper motor (WP 0158 00).</p>

Table 2. Electrical Troubleshooting Procedures (Non-Error Code) - Continued.

MALFUNCTION	TEST OR INSPECTION	CORRECTIVE ACTION
<p>14. Roof Windshield Wiper Motor Not Working.</p>	<p>1. Check circuit breaker F15 for trip.</p> <p>2. Inspect wiper arm for binding or damage.</p> <p>3. Check voltage (24V) at X8 pin 7, 8, and 9 with the ignition on while operating the roof wiper control switch. There should be voltage (24V) at pin 8 and 9, and intermittent voltage at pin 7.</p>	<p>a. Reset circuit breaker as required.</p> <p>b. If breaker does not reset, use the wiring diagram to check circuit for short to ground (WP 0048 00-36). Replace any shorted or grounded harnesses (WP 0113 00).</p> <p>c. Replace damaged or faulty circuit breaker (WP 0074 00).</p> <p>a. Correct binding wiper arm (WP 0158 00).</p> <p>b. Replace damage wiper arm (WP 0158 00).</p> <p>a. If no voltage (24V) is found at X8 pin 9, check circuit breaker F15 and continuity of wire A89 (WP 0048 00-38).</p> <p>b. If no voltage (24V) is found at X8 pin 7 or 8 while operating the roof wiper control switch, check roof wiper switch for damage and continuity and check continuity of wires 87, 88, and 89 (WP 0048 00-38).</p> <p>c. Replace damaged or faulty roof wiper switch (WP 0073 00).</p> <p>d. Repair or replace damaged wires or connectors (WP 0113 00).</p>

Table 2. Electrical Troubleshooting Procedures (Non-Error Code) - Continued.

MALFUNCTION	TEST OR INSPECTION	CORRECTIVE ACTION
<p>14. Roof Windshield Wiper Motor Not Working - Continued.</p>	<p>4. Remove the cover to gain access to the roof windshield wiper motor at front of cab (WP 0158 00 00). Inspect wiper motor for damage and wiring connections. Unplug wiper motor and check voltage (24V) at XS6 pin 2 and 3 with the ignition on while operating the roof wiper control switch.</p>	<p>a. If no voltage (24V) is found at SX6 pin 2 or 3, check continuity of wires A89A, A93, A246, 246, A88, 249, A87, and 244 (WP 0048 00-38). b. Check ground connection at wiper motor. Check continuity of wire 241A and ground connection at 37-2 (WP 0048 00-38). c. Repair or replace damaged wires or connectors (WP 0113 00). d. Replace damaged or faulty rear wiper motor (WP 0158 00).</p>
<p>15. Windshield Washer Not Working.</p>	<p>1. Check washer reservoir for damage and washer solvent level.</p> <p>2. Inspect washer pump, tubing, fittings, connectors, and wiring for damage.</p> <p>3. Check circuit breaker F9 for trip.</p> <p>4. Check voltage (24V) at X20 pin 1 and 3 with the ignition on and the washer switch depressed.</p>	<p>a. Fill washer reservoir with proper washer solvent (TM 10-3930-675-10). b. Replace damaged washer reservoir (WP 0159 00). a. Replace damaged tubing or fittings (WP 0159 00). b. Replace damaged washer pump (WP 0159 00). c. Repair or replace damaged harnesses or connectors (WP 0113 00). Reset circuit breaker as required. a. If no voltage (24V) is found at X20 pin 1, check circuit breaker F9 and check continuity of wire A201 (WP 0048 00-38). b. If no voltage (24V) is found at X20 pin 3, check continuity of wires 201 and 203 (WP 0048 00-40).</p>

Table 2. Electrical Troubleshooting Procedures (Non-Error Code) - Continued.

MALFUNCTION	TEST OR INSPECTION	CORRECTIVE ACTION
<p>15. Windshield Washer Not Working - Continued.</p>	<p>5. Check voltage. Unplug the washer pump and check for voltage (24V) between the two pins of the harness with the ignition on and the washer switch depressed.</p> <p>6. Check resistance. Unplug the washer pump and check resistance of the pump. Resistance should be 3 to 4 Ohms.</p>	<p>c. Check accessory control lever for damage and continuity (WP 0048 00-40).</p> <p>d. Replace damaged or faulty accessory control lever (WP 0234 00).</p> <p>a. If no voltage (24V) is found, check continuity of wires A203, 131, A135A, and ground connection of wire A132D at 37-1 (WP 0048 00-40).</p> <p>b. Repair or replace damaged wires or connector (WP 0113 00).</p> <p>If there is no resistance or pump fails test, replace washer pump (WP 0159 00).</p>
<p>CAB INTERIOR LIGHTS AND 12V UTILITY</p>		
<p>16. Cab Interior Light Not Working.</p>	<p>1. Check position of blackout drive/marker light switch.</p> <p>2. Check the operation of the emergency flashers.</p> <p>3. Inspect cab interior light for damage or burned out lamps.</p> <p>4. Check voltage (24V) at cab interior light between the gray and white wires. Check continuity of light switch.</p>	<p>Place blackout drive/marker light switch in OFF position.</p> <p>a. If emergency flashers do not work, perform troubleshooting procedure “<i>Turn Signals or Emergency Flashers Not Working</i>” in this work package.</p> <p>b. Continue with step 3.</p> <p>a. Replace burned out lamps (WP 0089 00).</p> <p>b. Replace damaged cab interior light (WP 0089 00).</p> <p>a. If no voltage (24V) is found, check continuity of wires 248, A69, 241B, and connection at 37-2 (WP 0048 00-40).</p>

Table 2. Electrical Troubleshooting Procedures (Non-Error Code) - Continued.

MALFUNCTION	TEST OR INSPECTION	CORRECTIVE ACTION
16. Cab Interior Light Not Working - Continued.		b. If the switch is damaged or faulty, replace cab interior light (WP 0089 00).
17. 12V Utility Plug Not Working.	<ol style="list-style-type: none"> 1. Check circuit breaker F14 for trip. 2. Check voltage at the 12V utility plug, with the ignition on, between pins 1 and 4. There should be 12V. Check voltage between pins 2 and 4. There should be 24V. 3. Check the 5 amp fuse on the voltage converter. 4a. With the ignition on, check the input voltage (24V) of the voltage converter to one of the two middle pins on the converter. 4b. With the ignition on, check the input voltage (24V) of between the two middle pins of the converter. 4c. With the ignition on, check the output voltage (12V) of the converter to one of the two middle pins on the converter. 	<p>Replace circuit breaker as required.</p> <ol style="list-style-type: none"> a. If voltage (24V) is found at pin 2 and none at pin 1, remove the cab electrical distribution box to gain access to the voltage converter. b. If no voltage (24V) is found at pin 2, check circuit breaker F14 and continuity of wires 108, A108A, 101, 102, and A102 (WP 0048 00-40). c. Repair or replace damaged wires or connectors (WP 0113 00). <p>Replace the 5 amp fuse if blown.</p> <ol style="list-style-type: none"> a. If no input voltage (24V) is found, check circuit breaker F14 and check continuity of wire A108 (WP 0048 00-40). b. Reinstall jumper wire A101B and check wires A101A and A101 continuity/ground connection at 37-5 (WP 0048 00-40). c. If no output voltage from converter is found, replace voltage converter (WP 0074 00).

Table 2. Electrical Troubleshooting Procedures (Non-Error Code) - Continued.

MALFUNCTION	TEST OR INSPECTION	CORRECTIVE ACTION
<p>18. Blower Motor Not Working.</p>	<ol style="list-style-type: none"> 1. Check circuit breaker F11 for trip. (For rear blower troubleshooting, go to step 8.) 2. Remove cab side filter and check blower for damage or the blower wheel for binding (WP 0191 00). 3. Remove the kick panel in front of the steering column and check blower assembly wiring and connectors for damage (WP 0191 00). 4. Check voltage (24V) at X9 pin 6 and 9 with the ignition on while operating the fan control switch. There should be varied voltage (14 to 24V) at pin 6. 	<ol style="list-style-type: none"> a. Reset circuit breaker as required. b. If breaker does not reset, use the wiring diagram to check circuit for short to ground (WP 0048 00-39). Replace any shorted or grounded harnesses (WP 0113 00). c. Replace damaged or faulty circuit breaker (WP 0074 00). <p>Replace damaged or binding blower motor/assembly (WP 0191 00).</p> <p>Repair or replace damaged harnesses or connectors (WP 0113 00).</p> <ol style="list-style-type: none"> a. If no voltage (24V) is found at X9 pin 9, check circuit breaker F11 and continuity of wires A99 and 99 (WP 0048 00-39). b. If no voltage (14 to 24V) is found at X9 pin 6 at any on speed, remove fan control switch and check for continuity (WP 0113 00). c. Replace damaged or faulty switch (WP 0073 00). d. If switch is good, check the continuity of wires 96, 97, 98, A96, A97, and A98 (WP 0048 00-39). e. Repair or replace damaged wires or connectors (WP 0113 00).

Table 2. Electrical Troubleshooting Procedures (Non-Error Code) - Continued.

MALFUNCTION	TEST OR INSPECTION	CORRECTIVE ACTION
<p>18. Blower Motor Not Working - Continued.</p>	<p>5. Check for voltage. Unplug connector X657 located behind the left air conditioning duct of the air conditioning assembly. Check for voltage (24V) at X657 pin 2, 3, and 4 with the ignition on while operating the fan control switch. There should be voltage (24V) at pin 2 for LOW, pin 4 for MED, and pin 3 for HIGH.</p> <p>6. Check the ground connection for the white wire at X657 pin 1 and at 37-10.</p> <p>7. Unplug the two wires (BK and OR) from the blower motor. Check for voltage between the two connectors with the ignition on while operating the fan control switch to HIGH speed.</p> <p>8. Remove the plastic panel at the right rear of the cab to access the rear blower. Remove the outlet duct and check for binding blower wheel or damage to the motor or wiring (WP 0191 00).</p> <p>9. Check voltage (24V) at X69 pin 1 with the ignition on while operating the fan control switch. There should be varied voltage (14 to 24V).</p> <p>10. Unplug connector X657-1 and check voltage (24V) with the ignition on while operating the fan control switch to HIGH speed.</p>	<p>a. If no voltage is found, check continuity of wires, 271, 272, and 273 (WP 0048 00-39).</p> <p>b. Repair or replace damaged wires or connectors (WP 0113 00).</p> <p>Repair or replace damaged wires or connectors (WP 0113 00).</p> <p>a. If no voltage is found, replace the internal blower assembly harness (WP 0191 00).</p> <p>b. If voltage is found, replace blower motor/assembly (WP 0191 00).</p> <p>a. Replace damaged or binding blower motor/assembly (WP 0191 00).</p> <p>b. Repair or replace damaged wires or connectors (WP 0113 00).</p> <p>If no voltage is found and front blower operates properly, check continuity of wires A691 and A692 (WP 0048 00-36).</p> <p>a. If no voltage (24V) is found, check continuity of wires BU and BK (WP 0048 00-36).</p> <p>b. If voltage is found, replace rear blower motor/assembly (WP 0191 00).</p>

Table 2. Electrical Troubleshooting Procedures (Non-Error Code) - Continued.

MALFUNCTION	TEST OR INSPECTION	CORRECTIVE ACTION
<p>19. Heater/Defroster Producing Low or No Heat.</p>	<ol style="list-style-type: none"> 1. Check operating temperature of engine. 2. Inspect the two heater hoses between the cab and chassis for kinks. 3. Check operation of blower (TM 10-3930-675-10). 4. Check operation of heater temperature control switch and heater/defroster selection switch operation (TM 10-3930-675-10). See step 5 before replacing any switch. 5a. Remove kick panel from in front of the steering column. Check the operation of the heater control valve and cable (WP 0191 00). 5b. Check operation of the air flow door while operating the heater/defrost selection switch. 6. Check ducts. With the kick panel removed, check the air conditioning ducts for any damage or separations. 7. Check airflow through heater core. 	<ol style="list-style-type: none"> a. Perform proper PMCS for coolant system (TM 10-3930-675-10). b. Warm engine to proper operating temperature (TM 10-3930-675-10). a. Straighten any kinked hoses (WP 0190 00). b. Replace any damaged hoses or kinked hose that will not straighten (WP 0190 00). If blower not functioning, perform troubleshooting procedure for “<i>Blower Motor Not Working</i>” in this work package. a. Replace damaged or binding heater temperature control switch (WP 0073 00). b. Replace damaged or binding heater/defroster selection switch (WP 0073 00). a. Replace bent or kinked control cable (WP 0073 00 and WP 0191 00). b. Replace damaged, leaking, or non-operational heater control valve (WP 0191 00). c. Correct any binding of air flow door and cable. Repair or replace any damaged or separated ducts. If air flow is very low through heater core, perform A/C system maintenance (WP 0265 00).

Table 2. Electrical Troubleshooting Procedures (Non-Error Code) - Continued.

MALFUNCTION	TEST OR INSPECTION	CORRECTIVE ACTION
<p>20. A/C System Not Cooling Properly.</p>	<ol style="list-style-type: none"> 1. Check operation of blower (TM 10-3930-675-10). 2. Remove the engine cover and inspect the condition of the A/C compressor belts. 3. Check for proper operation. Turn the blower to high, press the A/C control switch and turn A/C temperature control switch to maximum cool. Observe if A/C compressor clutch engages, compressor engages, and compressor operates. Observe if the condenser fans are on. 4. Check for proper operation. Run the A/C system for about 15 minutes to stabilize. Feel the air coming from the condenser fans; it should be warmer than the ambient temperature. Feel the temperature of the larger pipe connected to the compressor; it should be cool or cold and possibly sweating. 5. Check voltage (24V) at X27 pin 4 and 5 while operating the A/C system to maximum cool. 	<p>If blower not functioning, perform troubleshooting procedure for “<i>Blower Motor Not Working</i>” in this work package.</p> <p>Replace and/or adjust belts as required (WP 0195 00).</p> <ol style="list-style-type: none"> a. If compressor operates and condenser fans are on, go to step 4. b. If compressor does not operate, perform steps 5, 6, and 7. c. If condenser fans do not operate, perform steps 8, 9, and 10. <ol style="list-style-type: none"> a. If condenser air is warm and the compressor pipe is cool/cold, check if the heater control valve is fully closed and the air is properly flowing through the ducts (WP 0195 00). b. If condenser air is not warm and the compressor pipe is not cool/cold, perform A/C system maintenance (WP 0265 00). <ol style="list-style-type: none"> a. If no voltage (24V) is found at X27 pin 4, remove the A/C control switch and check continuity of wires 99A, 95, and A95 (WP 0048 00-39). b. If no voltage (24V) is found at X27 pin 5, remove A/C temperature control switch and check continuity of wires 274 and 275 (WP 0048 00-39).

Table 2. Electrical Troubleshooting Procedures (Non-Error Code) - Continued.

MALFUNCTION	TEST OR INSPECTION	CORRECTIVE ACTION
<p>20.A/C System Not Cooling Properly - Continued.</p>	<p>6. Check voltage (24V) at X17 pin 8 while operating the A/C system to maximum cool.</p> <p>7. Check the wire connector at the compressor clutch. Unplug the connector and check voltage (24V) while operating the A/C system to maximum cool.</p> <p>8. Check circuit breaker F1 for trip. Unplug X810 and check voltage (24V) at X810 pins 1 and 2 while operating the A/C system.</p>	<p>c. Replace damaged or faulty switch (WP 0073 00).</p> <p>a. If no voltage (24V) is found at X17 pin 8, check continuity of wires A327, 327, 328, and A178 (WP 0048 00-39).</p> <p>b. If no voltage (24V) is found at X17 pin 8 and all wires are functioning properly, remove the cover of the condenser and unplug the pressure switch. Check continuity of the pressure switch between wires RD/WH and BK/WH (X810 pins 3 and 4).</p> <p>c. If no continuity is found at pressure switch, perform A/C system maintenance (WP 0265 00) to check the refrigerant charge of the system.</p> <p>a. If no voltage (24V) is found, check continuity of wire 178 (WP 0048 00-39).</p> <p>b. If voltage (24V) is found, check the resistance of the compressor clutch to ground. Resistance should be 12 to 16 Ohms.</p> <p>c. If resistance of compressor clutch is not as specified, replace compressor (WP 0266 00).</p> <p>a. Reset circuit breaker as required.</p> <p>b. If no voltage (24V) is found at X810 pin 2, check continuity of wires A95A and 322 (WP 0048 00-39).</p>

Table 2. Electrical Troubleshooting Procedures (Non-Error Code) - Continued.

MALFUNCTION	TEST OR INSPECTION	CORRECTIVE ACTION
<p>20.A/C System Not Cooling Properly - Continued.</p>	<p>9. Remove the cover of the condenser and check the fans, relays, and wiring for damage (WP 0196 00).</p> <p>10. Check resistance of fans and resistors. Resistance should be around 2 Ohms.</p>	<p>c. If no voltage (24V) is found at X810 pin 3, check circuit breaker F1 and continuity of wires A323 and 323 (WP 0048 00-39).</p> <p>d. Check continuity of wires (X810 pin 6) 329, A329, and ground connection at 37-5 (WP 0048 00-39).</p> <p>e. Repair or replace damaged wires or connectors (WP 0113 00).</p> <p>a. Remove relays and test (WP 0113 00).</p> <p>b. Replace damaged or faulty relay (WP 0074 00).</p> <p>c. Replace damaged fan(s) (WP 0196 00).</p> <p>d. Repair or replace damaged wires or connectors (WP 0113 00).</p> <p>If resistance is not as specified, replace faulty fan(s) or resistor(s) (WP 0196 00).</p>
<p>EMERGENCY/SAFETY OVERRIDE SYSTEMS</p> <p>21. Fuel Gage Not Working Properly.</p>	<p>1. Check circuit breaker F7 for trip.</p> <p>2. Check fuel level sending unit on top of fuel tank for damage.</p> <p>3. Check fuel gage for damage. Remove the dash panel to access the fuel gage. Check the wire connector for damage or disconnection (WP 0073 00 00).</p>	<p>Reset circuit breaker as required.</p> <p>Replace damaged fuel level sending unit (WP 0095 00).</p> <p>a. Replace damaged fuel gage (WP 0073 00).</p> <p>b. Repair or replace damaged wires or connectors (WP 0113 00).</p>

Table 2. Electrical Troubleshooting Procedures (Non-Error Code) - Continued.

MALFUNCTION	TEST OR INSPECTION	CORRECTIVE ACTION
<p>21. Fuel Gage Not Working Properly - Continued.</p>	<p>4. Check for voltage. With the fuel gage removed and the ignition on, check for voltage (24V) at the + terminal of the gage.</p> <p>5. Check float and rod. Unplug the fuel sending unit and remove it from the fuel tank (WP 0095 00). Check the float for damage, sticking, or "waterlog." Check the rod for damage and for float travel.</p> <p>6. Check resistance of fuel level sending unit; float at bottom = 110 Ohms, float in middle = approx. 50 Ohms, and float at top = <1 Ohm.</p> <p>7. Check for proper operation. With the fuel level sending unit removed, reconnect the plug to the harness. Turn the ignition on and move the float up and down. Observe the movement of the gage. (Ensure the fuel sending unit rod slides into the lower support when reinstalling back into the tank.)</p>	<p>If no voltage (24V) is found, check circuit breaker F7 and continuity of wires A211, A104, and 104 (WP 0048 00-37).</p> <p>Replace damaged fuel level sending unit (WP 0095 00).</p> <p>a. If resistance is not as specified, replace faulty fuel level sending unit (WP 0095 00).</p> <p>b. If resistance checks good, check continuity of wires 258, 259, A105, 105, and ground wire A132D at the 37-1 ground connection (WP 0048 00-37).</p> <p>c. Repair or replace damaged wires or connectors (WP 0113 00).</p> <p>a. If gage does not react to float movement, replace faulty gage (WP 0073 00).</p> <p>b. If gage does react but does not match with the float level, try adjusting the small adjustment screw on gage to "empty" with the float at the bottom. Retest float/gage reactions.</p>

Table 2. Electrical Troubleshooting Procedures (Non-Error Code) - Continued.

MALFUNCTION	TEST OR INSPECTION	CORRECTIVE ACTION
<p>22. Driver's ECS Display Screen Will Not Display.</p>	<ol style="list-style-type: none"> 1. Check circuit breaker F31 for trip. 2. Check voltage (24V) at X150 pin 3 with the ignition on. 3. Check voltage (24V) at X152 pin 3 with the ignition on. 4. Check voltage. Gain access to the ECS display screen in the steering column console (WP 0081 00). Unplug X795 from the ECS display screen. Check voltage (24V) at X795 pins 7 and 8 with the ignition on. 	<p>Reset circuit breaker as required.</p> <ol style="list-style-type: none"> a. If no voltage (24V) is found at X150 pin 3, check circuit breaker F31 and continuity of wires A303 and 303 (WP 0048 00-32). b. Repair or replace damaged wires or connectors (WP 0113 00). c. Replace damaged or faulty circuit breaker (WP 0074 00). a. If no voltage is found at X152 pin 3, check continuity of wire A1503B (WP 0048 00-2). b. Repair or replace damaged wires or connectors (WP 0113 00). a. If no voltage is found at X795 pin 7 or 8, check continuity of wires 1523A and 1523B (WP 0048 00-2). b. Repair or replace damaged wires or connectors (WP 0113 00). c. If voltage (24V) is found, replace the ECS display screen (WP 0081 00).
<p>23. After Key "On" Functions Not Working (No Crank, Display, etc.).</p>	<ol style="list-style-type: none"> 1. Check for proper function. With the master switch turned on and the ignition turned off, activate the turn signals/emergency flashers and cab interior light. 	<ol style="list-style-type: none"> a. If all of these functions work properly, continue with step 4. b. If none of these functions work properly, continue with step 2.

Table 2. Electrical Troubleshooting Procedures (Non-Error Code) - Continued.

MALFUNCTION	TEST OR INSPECTION	CORRECTIVE ACTION
<p>23. After Key “On” Functions Not Working (No Crank, Display, etc.) - Continued.</p>	<p>2. Check voltage (24V) at X80 all pins.</p> <p>3. Check voltage (24V) at batteries, master battery switch, and starter solenoid on the starter (WP 0048 00-33).</p> <p>4. Check voltage (24V) at X8 pins 3 and 4 with the ignition on.</p>	<p>a. If no voltage (24V) is found, check circuit breakers F50-1 and F50-2 located at upper left rear of engine, and continuity of wires 801 and 803 (WP 0048 00-31).</p> <p>b. Repair or replace damaged wires or connectors (WP 0113 00).</p> <p>c. Replace damaged or faulty circuit breaker (WP 0074 00).</p> <p>a. Service batteries (WP 0108 00 00).</p> <p>b. Repair or replace damaged or faulty battery cables (WP 0110 00).</p> <p>c. Replace damaged or faulty master battery switch (WP 0111 00).</p> <p>a. If no voltage (24V) is found at X8 pin 3, check circuit breaker F2 and continuity of wire A83 (WP 0048 00-31).</p> <p>b. If no voltage (24V) is found at X8 pin 4, check ignition switch for damage and continuity and check continuity of wire 84 (WP 0048 00-31).</p> <p>c. Replace damaged or faulty ignition switch (WP 0073 00).</p> <p>d. Repair or replace damaged wires or connectors (WP 0113 00).</p>

Table 2. Electrical Troubleshooting Procedures (Non-Error Code) - Continued.

MALFUNCTION	TEST OR INSPECTION	CORRECTIVE ACTION
<p>23. After Key “On” Functions Not Working (No Crank, Display, Etc.) - Continued.</p>	<p>5. Check voltage (24V) at relay 315 terminal 30 and 87 (two brass terminals) and terminal 86 (white plug; gray wires) with ignition on.</p> <p>6. Check continuity of wire A84C and its ground connection at 37-1 (WP 0048 00-32).</p> <p>7. Check wiring. All after key circuit breakers are energized from four wires connected to relay 315 terminal 87. Check continuity of wires A805A, A806A, A807A, and A808A to each after key circuit breaker group (WP 0048 00-32).</p>	<p>a. If no voltage (24V) is found at 315 terminal 30, check continuity of wire A804 (WP 0048 00-32).</p> <p>b. If no voltage (24V) is found at 315 terminal 86, check continuity of wire A84 (WP 0048 00-32).</p> <p>c. If no voltage (24V) is found at 315 terminal 87, test relay 315 (WP 0113 00).</p> <p>d. Replace damaged or faulty relay (WP 0074 00).</p> <p>e. Repair or replace damaged or loose wires or connectors (WP 0113 00).</p> <p>Repair or replace damaged or loose wires or connectors (WP 0113 00).</p> <p>a. Repair or replace damaged or loose wires or connectors (WP 0113 00).</p> <p>b. Check jumper connections between circuit breakers (WP 0048 00-32).</p>

Table 2. Electrical Troubleshooting Procedures (Non-Error Code) - Continued.

MALFUNCTION	TEST OR INSPECTION	CORRECTIVE ACTION
<p>24. Proximity Switches - Tophandler and Cab.</p>	<p style="text-align: center;">NOTE</p> <ul style="list-style-type: none"> • All proximity switches on the RTCH operate and are connected the same way. Many non-error code problems may be caused by a faulty proximity switch or the proximity switch signal not reaching its destination. DIAG ATTACHMENT screens 3(16), 4(16), 5(16), and DIAG EXTRA FUNCT 8(13) can be used to verify the signal inputs into the ECU (790) or (791). • All Proximity Switches - General operation. Each proximity switch has three wires: <ul style="list-style-type: none"> - Brown = voltage (24V) input - Blue = ground - Black = signal; voltage (24V) output when activated • Activation = metal within 5 mm of end of proximity switch. • Indicator = small LED comes on when activated. <p>Check proximity switches:</p> <p>Tophandler Proximity Switches</p> <ol style="list-style-type: none"> 1. Voltage (24V) to proximity switches comes from circuit breaker F42 (2) in the tophandler junction box. The main grounding point is 37-54 (WP 0048 00-23 and WP 0048 00-24). 2. Check voltage (24V) at X182 between pins 4 and 5 (WP 0048 00-24) with the ignition on. 	<p style="text-align: center;">NOTE</p> <ol style="list-style-type: none"> a. Reset circuit breaker as required. b. Replace damaged or faulty circuit breaker (WP 0074 00). c. Repair or replace damaged wires or connectors (WP 0113 00). <ol style="list-style-type: none"> a. If no voltage (24V) is found, check continuity of wires A181A, A181B, and wires 4 and 5 in the X181 to X182 cable (WP 0048 00-24). b. Repair or replace damaged wires or connectors (WP 0113 00). c. Replace X181 to X182 cable (WP 0113 00).

Table 2. Electrical Troubleshooting Procedures (Non-Error Code) - Continued.

MALFUNCTION	TEST OR INSPECTION	CORRECTIVE ACTION
<p>24.Proximity Switches - Tophandler and Cab - Continued.</p>	<p>3. Check voltage (24V) at X183 between pins 3 and 4 (WP 0048 00-24) with the ignition on.</p> <p>4. Check voltage (24V) at X184 between pins 3 and 4 (WP 0048 00-24) with the ignition on.</p> <p>5. For RESET or USMC only, check voltage by disconnecting proximity switch 7225-1 mounted on the tophandler turning plate. Check voltage (24V) at the harness connector between pins A and B.</p>	<p>a. If no voltage (24V) is found, check continuity of wires 3 and 4 in the X182 to X183 cable (WP 0048 00-24).</p> <p>b. Repair or replace damaged wires or connectors (WP 0113 00).</p> <p>c. Replace X182 to X183 cable, electrical general maintenance (WP 0113 00).</p> <p>a. If no voltage (24V) is found, check continuity of wires 3 and 4 in the X182 to X184 cable (WP 0048 00-24).</p> <p>b. Repair or replace damaged wires or connectors (WP 0113 00).</p> <p>c. Replace X182 to X183 cable (WP 0113 00).</p> <p>a. If no voltage (24V) is found, check continuity of wires A194E, A194F, 194G (RD), and 194E (GY).</p> <p>b. Repair or replace damaged wires or connectors (WP 0113 00).</p> <p>c. Replace X194 cable (WP 0113 00).</p>
<p>NOTE</p> <p>The 7225-1 proximity switch operation can be quickly tested by turning on the tophandler work lights and rotating the tophandler CW towards the longitudinal position. 7225-1, when deactivated, turns off the tophandler work lights beyond 40 degrees of CW rotation.</p>		

Table 2. Electrical Troubleshooting Procedures (Non-Error Code) - Continued.

MALFUNCTION	TEST OR INSPECTION	CORRECTIVE ACTION
<p>24.Proximity Switches - Tophandler and Cab - Continued.</p>	<p>6. Turn the ignition on and manually activate the proximity switch by operating a specific function or by placing a piece of metal within 5 mm of the end. Check for the indicator LED on the switch.</p> <p>7. Manually activate the proximity switch by operating a specific function or by placing a piece of metal within 5 mm of the end. Disconnect ECU (791) connector 1. Turn the ignition on and check voltage (24V) at pins 30 through 40 (WP 0048 00-25) (pin 10 for RESET or USMC).</p> <p>Cab Proximity Switches</p> <p>1. Voltage (24V) to proximity switches comes from circuit breaker F29 (F33 for RESET or USMC) in the electrical distribution box. The main grounding point is 37-52 (WP 0048 00-16, WP 0048 00-18, WP 0048 00-29, and WP 0048 00-30).</p>	<p>If no LED indicator when activated, check voltage and ground inputs and adjustment first; replace proximity switch (WP 0075 00).</p> <p>a. If no voltage (24V) is found for the specific proximity switch signal, check continuity of wires A181C through A181K (WP 0048 00-25) and A194G for RESET or USMC.</p> <p>b. Check continuity of specific wire in X181 to X182 cable (WP 0048 00-24).</p> <p>c. Check continuity of specific wire in X182 to X183 cable or X182 to X184 cable (WP 0048 00-24).</p> <p>d. Repair or replace damaged wires or connectors (WP 0113 00).</p> <p>e. Replace X181 to X182 cable, or X183 cable, or X182 to X184 cable or X194 cable (WP 0113 00).</p> <p>a. Reset circuit breaker as required.</p> <p>b. Replace damaged or faulty circuit breaker (WP 0074 00).</p> <p>c. Repair or replace damaged wires or connectors (WP 0113 00).</p>

Table 2. Electrical Troubleshooting Procedures (Non-Error Code) - Continued.

MALFUNCTION	TEST OR INSPECTION	CORRECTIVE ACTION
<p>24.Proximity Switches - Tophandler and Cab - Continued.</p>	<p>2. Check voltage (24V) at X195 between pins 7 and 9 (WP 0048 00-29 and WP 0048 00-30) with the ignition on.</p> <p>3. Move the cab to the transport position (TM 10-3930-675-10). Check voltage (24V) at X198 between pins 1 and 3 (WP 0048 00-29) with the ignition on.</p> <p>4. Check voltage. With the ignition on, activate the under cab proximity switch (7208) with a piece of metal. Check voltage (24V) between X195 pin 5 and 7 (WP 0048 00-14 and WP 0048 00-30). Check LED indicator on the switch.</p> <p>5. Check voltage (24V) at X175 between pins 1 and 3 (WP 0048 00-30) with the ignition on.</p>	<p>a. If no voltage (24V) is found, check continuity of wires A473, 473, A1743B, A1743C, and A1957A (WP 0048 00-32, WP 0048 00-16, WP 0048 00-18, WP 0048 00-29, and WP 0048 00-30). For RESET or USMC, check wires A475, 475, A174B1A, A174B1B, and A1957A (WP 0048 00-18, WP 0048 00-29, WP 0048 00-30, and WP 0048 00-32).</p> <p>b. Repair or replace damaged wires or connectors (WP 0113 00).</p> <p>a. If no voltage (24V) is found, check continuity of wires GY and RD in the X195 to X198 cable (WP 0048 00-29).</p> <p>b. Replace X195 to X198 cable (WP 0113 00).</p> <p>a. If no voltage (24V) is found, check continuity of wire OR in the X195 to X198 cable (WP 0048 00-14).</p> <p>b. If no LED indicator when activated, replace proximity switch (WP 0076 00).</p> <p>c. Replace X195 to X198 cable (WP 0113 00).</p> <p>a. If no voltage (24V) is found, check continuity of wires A1743D, A1957B, and for RESET or USMC, wire A174B1C (WP 0048 00-29 and WP 0048 00-30).</p> <p>b. Repair or replace damaged wires or connectors (WP 0113 00).</p>

Table 2. Electrical Troubleshooting Procedures (Non-Error Code) - Continued.

MALFUNCTION	TEST OR INSPECTION	CORRECTIVE ACTION
<p>24. Proximity Switches - Tophandler and Cab - Continued.</p>	<p>6. Check voltage. With the ignition on, activate the side of cab proximity switch (7210) with a piece of metal. Check voltage (24V) between X175 pin 2 and 3 (WP 0048 00-30). Check LED indicator.</p>	<p>If no voltage (24V) or LED indicator when activated, replace proximity switch (WP 0076 00).</p>
<p>25. Normal Functions Operate in Blackout Mode.</p>	<p>1. Check for horn operation in blackout mode.</p> <p>2. Check for backup lights/alarm in blackout mode.</p> <p>3. Check for boom work light operation in blackout mode.</p> <p>4. Check for stoplight operation in blackout mode.</p> <p>5. Check operation of the parking brake warning seat buzzer in blackout mode.</p>	<p>a. If horn operates, remove relay 3016 and test WP 0113 00).</p> <p>b. Replace damaged or faulty relay (WP 0074 00).</p> <p>a. If backup lights/alarm operate, remove relay 3011 and test (WP 0113 00).</p> <p>b. Replace damaged or faulty relay (WP 0074 00).</p> <p>a. If boom work lights operate, remove relay 3013 and test (WP 0113 00).</p> <p>b. Replace damaged or faulty relay (WP 0074 00).</p> <p>a. If stoplights operate, remove relay 3010 and test (WP 0113 00).</p> <p>b. Replace damaged or faulty relay (WP 0074 00).</p> <p>a. If seat buzzer operates, remove relay 3016-1 and test (WP 0113 00).</p> <p>b. Replace damaged or faulty relay (WP 0074 00).</p>
<p>26. Multiple Boom or Tophandler Functions Not Working (Multiple Error Codes).</p>	<p>1. Check for the following groups:</p> <p>a. No boom functions, hydraulic pumps engaged when cranking (slow or hard crank), cooling fan at full speed. Multiple error codes.</p>	<p>a. For a, proceed with step 3.</p> <p>b. For b, proceed with step 4.</p> <p>c. For c, proceed with step 5.</p> <p>d. For b and c, proceed with step 6.</p>

Table 2. Electrical Troubleshooting Procedures (Non-Error Code) - Continued.

MALFUNCTION	TEST OR INSPECTION	CORRECTIVE ACTION
<p>26. Multiple Boom or Tophandler Functions Not Working (Multiple Error Codes) - Continued.</p>	<p>b. No sideshift, no 20/40 spread, and no twistlock operation. Multiple error codes.</p> <p>c. No rotate, no tilt, no oscillate, and no twistlock lights on boom. Multiple error codes.</p> <p>2. Check for emergency stop in engaged position. (Multiple error codes will display if the emergency stop button is engaged during crank and start.)</p> <p>3. Check voltage (24V) at X159 pin 1 with the ignition on. (Checking the common 24V output from ECU 790 connector 2 pin 10; any short to ground causes the voltage to drop to 6V or less (WP 0048 00-8).)</p>	<p>Disengage emergency stop button. (Error codes 121 and 201 will normally be one of the error codes displayed.)</p> <p>a. If voltage is 6V or less, unplug X158, turn the ignition off, then back on after 3 minutes. Recheck voltage.</p> <p>b. If the voltage (24V) returns to X159 pin 1, check continuity of each pin of the loose part of X158 to ground (WP 0048 00-8).</p> <p>c. If the voltage (24V) does not return, unplug X159, turn the ignition off, then back on after 3 minutes. Recheck voltage.</p> <p>d. If the voltage (24V) returns to X159 pin 1, check continuity of each pin 1 and 2 of the loose part of X159 to ground (WP 0048 00-8).</p> <p>e. If continuity to ground found at any pin(s), follow the circuit of the pin/wire to the component it goes to. Unplug the component and recheck for continuity to ground. Replace grounded harness (WP 0048 00-8).</p>

Table 2. Electrical Troubleshooting Procedures (Non-Error Code) - Continued.

MALFUNCTION	TEST OR INSPECTION	CORRECTIVE ACTION
<p>26. Multiple Boom or Tophandler Functions Not Working (Multiple Error Codes) - Continued.</p>	<p>4. Check voltage (24) at X180 pin 15 with the ignition on. Checking the common 24V output from ECU 791 connector 2 pin 10, any short to ground causes the voltage to drop to 6V or less (WP 0048 00-26).</p> <p>5. Check voltage (24) at X180 pin 13 with the ignition on. Checking the common 24V output from ECU 791 connector 3 pin 10; any short to ground causes the voltage to drop to 6V or less (WP 0048 00-27).</p>	<p>a. If voltage is 6V or less, unplug X188, turn the ignition off, then back on after 3 minutes. Recheck voltage.</p> <p>b. If the voltage (24V) returns to X180 pin 15, check continuity of each pin J, K, L, M, N, and P of the loose part of X188 to ground (WP 0048 00-26).</p> <p>c. If voltage (24V) does not return, unplug X189, turn the ignition off, then back on after 3 minutes. Recheck voltage.</p> <p>d. If the voltage (24V) returns to X180 pin 15, check continuity of each pin A, B, C, D, J, K, L, M, N, and P of the loose part of X189 to ground (WP 0048 00-26).</p> <p>e. If continuity to ground is found at any pin(s), follow the circuit of the pin/wire to the component it goes to. Unplug the component and recheck for continuity to ground. Replace grounded harness (WP 0048 00-26).</p> <p>a. If voltage is 6V or less, unplug X188, turn the ignition off, then back on after 3 minutes. Recheck voltage.</p> <p>b. If the voltage (24V) returns to X180 pin 13, check continuity of each pin A, B, C, D, E, F, G, and H of the loose part of X188 to ground (WP 0048 00-27).</p>

Table 2. Electrical Troubleshooting Procedures (Non-Error Code) - Continued.

MALFUNCTION	TEST OR INSPECTION	CORRECTIVE ACTION
<p>26. Multiple Boom or Tophandler Functions Not Working (Multiple Error Codes) - Continued.</p>	<p>6. Test relay. Remove relay 3009-3 and test (WP 0113 00). Check voltage (24V) at 3009-3 relay socket pins 30 and 86 (WP 0048 00-23) with the ignition on.</p> <p>7. Check voltage. Disconnect ECU (791) connectors 2 and 3. Inspect ECU and connector pins for damage. Check voltage (24V) between pins 1 and 9 of each connector (WP 0048 00-23) with the ignition on.</p>	<p>c. If voltage (24V) does not return, unplug X189, turn the ignition off, then back on after 3 minutes. Recheck voltage.</p> <p>d. If continuity to ground is found at any pin(s), follow the circuit of the pin/wire to the component it goes to. Unplug the component and recheck for continuity to ground. Replace grounded harness (WP 0048 00-27).</p> <p>a. Replace damaged or faulty 3009-3 relay (WP 0074 00).</p> <p>b. If no voltage (24V) is found at 3009-3 pin 30, check circuit breaker F41 (1) and continuity of wires A51J, A51B, and A51D (WP 0048 00-23).</p> <p>c. Check operation of relay 315-1 (WP 0048 00-23), replace damaged or faulty 315-1 relay (WP 0074 00).</p> <p>d. If no voltage (24V) is found at 3009-3 pin 86, check continuity of wire A1803C (WP 0048 00-23).</p> <p>e. Repair or replace damaged wires or connectors (WP 0113 00).</p> <p>a. If no voltage (24V) is found at either connector, check continuity of wires A511, A51H, 791I, and 7912 (WP 0048 00-23).</p> <p>b. Repair or replace damaged wires or connectors (WP 0113 00).</p> <p>c. Replace ECU (791) (WP 0080 00).</p>

Table 2. Electrical Troubleshooting Procedures (Non-Error Code) - Continued.

MALFUNCTION	TEST OR INSPECTION	CORRECTIVE ACTION
<p>27. Function(s) Work Uncontrolled.</p>	<p>1. Check the following groups:</p> <ul style="list-style-type: none"> a. Boom functions b. Tophandler functions <p>An uncontrolled function is usually caused by a short to ground or a stuck hydraulic solenoid.</p> <p>2. Test for electrical or hydraulic fault. Start the engine (TM 10-3930-675-10) and engage the emergency stop button. If the uncontrolled function stops, it's electrical. If the function does not stop, it's hydraulic.</p> <p>Boom Functions, Electrical - Steps 3 through 5.</p> <p>3. Enter "DIAG SERVO" 5(13) in the diagnostic menu. The voltage should be 5V.</p> <p>4. Check joystick. Enter "DIAG SERVO" 9(13) and 10(13) in the diagnostic menu. The INPUT and OUTPUT should be <5mA with no joystick input.</p> <p>5. Unplug X158 and unplug the solenoid for the affected function, check continuity of the pins of the harness to ground for the affected function solenoid (WP 0048 00-8).</p> <p>Boom Functions, Hydraulic - Step 6.</p> <p>6. Check boom functions. Unplug the affected function hydraulic solenoid and start engine.</p>	<ul style="list-style-type: none"> a. For a, proceed with steps 3 through 6. b. For b, proceed with steps 7 through 11. <p>Disengage the emergency stop button after test.</p> <ul style="list-style-type: none"> a. If voltage is not 5V, proceed with step 4. b. If voltage is 5V, proceed with step 5. <p>If mA values > 5mA appear without operating the joystick, replace the joystick (WP 0082 00).</p> <p>Replace grounded harness (WP 0048 00-8).</p> <ul style="list-style-type: none"> a. If function still works, shut down engine and remove the affected solenoid. Check for debris or broken O-rings. Replace servo control valve (WP 0250 00). b. Replace main control valve (WP 0249 00).

Table 2. Electrical Troubleshooting Procedures (Non-Error Code) - Continued.

MALFUNCTION	TEST OR INSPECTION	CORRECTIVE ACTION
<p>27.Function(s) Work Uncontrolled - Continued.</p>	<p>7. Test voltage. Enter “DIAG SERVO” 6(13) in the diagnostic menu. The voltage should be 5V.</p> <p>8. Check amperage. Enter “DIAG ATTACH” 12(16) and 13(16) in the diagnostic menu. The INPUT and OUTPUT should be <5mA with no joystick input.</p> <p>9. Test for button stuck on condition. Enter “DIAG SERVO” screens 2(13) and 3(13) in the diagnostic menu. Each value should be “0” with no joystick buttons pressed.</p> <p>10. Check continuity, unplug X188 or X189, and unplug the solenoid for the affected function; check continuity of the pins of the harness to ground for the affected function solenoid (WP 0048 00-26 and WP 0048 00-27).</p> <p>Tophandler functions, Hydraulic Step 11.</p> <p>11. Unplug the affected function hydraulic solenoid and start engine.</p>	<p>a. If voltage is not 5V, proceed with step 8.</p> <p>b. If voltage is 5V, proceed with step 9.</p> <p>If mA values >5mA appear without operating the joystick, replace joystick (WP 0082 00).</p> <p>If a button appears to be stuck on, replace joystick (WP 0082 00).</p> <p>Replace grounded harness (WP 0048 00-26 and WP 0048 00-27).</p> <p>If function still works, shut down engine and remove the affected solenoid. Check for debris or broken O-rings. Replace faulty solenoid (WP 0171 00).</p>

Table 3. Brake System Troubleshooting Procedures (Non-Error Code).

MALFUNCTION	TEST OR INSPECTION	CORRECTIVE ACTION
<p>1. Braking is Poor or Nonexistent.</p>	<ol style="list-style-type: none"> 1. Ensure brake system accumulator shutoff valves are in CLOSED position. 2. Inspect brake pedals for damage and obstructions. 3. Check hydraulic brake lines and hoses for damage and signs of leakage. 4. Test brake charging valve opening pressure for brake system circuits 1 and 2, test points 1 and 2 (WP 0188 00 00). Check brake charging valve opening pressures and accumulator pre-charge nitrogen pressures. 5. Test operating pressures for brake system circuits 1 and 2, test points 4 and 5 (WP 0188 00 00). 	<p>Close shutoff valves as required (WP 0164 00).</p> <ol style="list-style-type: none"> a. Remove any obstructions. b. Repair or replace damaged brake pedal (WP 0132 00). a. Tighten loose connections. b. Replace damaged or leaking lines and hoses (WP 0127 00). a. If accumulator pre-charge nitrogen pressures are not normal, service accumulators (WP 0230 00). b. Replace service brake control valve (WP 0126 00). c. If operating pressure is low, replace boom and brake system pump (WP 0246 00). <p>Replace service brake control valve (WP 0126 00).</p>
<p>2. Parking Brake Will Not Release.</p>	<ol style="list-style-type: none"> 1. Ensure brake system accumulator shutoff valves are in CLOSED position. 2. Inspect parking brake control lever for damage and obstructions. 3. Check hydraulic brake lines and hoses for damage and signs of leakage. 	<p>Close shutoff valve as required (WP 0164 00).</p> <ol style="list-style-type: none"> a. Remove any obstructions. b. Replace damaged parking brake control valve (WP 0124 00). a. Tighten loose connections. b. Replace damaged or leaking lines and hoses (WP 0125 00).

Table 3. Brake System Troubleshooting Procedures (Non-Error Code) - Continued.

MALFUNCTION	TEST OR INSPECTION	CORRECTIVE ACTION
<p>2. Parking Brake Will Not Release - Continued.</p>	<p>4. Test brake charging valve opening pressure for brake system circuit 2, test point 4 (WP 0188 00 00).</p> <p>5. Check if transmission will engage and try to move forward or reverse.</p>	<p>a. Check parking brake calipers for parking brake release if pressure check is normal. Check pad adjustment (WP 0122 00).</p> <p>b. If parking brakes do not release at the calipers, replace the parking brake control valve (WP 0124 00).</p> <p>If transmission will engage but brake seems to be engaged, replace the parking brake flow control valve (923543.0005) located next to the brake system accumulator shutoff valves.</p>
<p>3. Parking Brake Will Not Engage.</p>	<p>1. Inspect front and rear parking brake assemblies and brake pads for wear and damage.</p> <p>2. Check parking brake pads for proper adjustment.</p> <p>3. Inspect parking brake control lever for obstructions and damage.</p> <p>4. Check hydraulic brake hoses and lines for damage and signs of leakage.</p>	<p>a. Replace worn parking brake pads (WP 0122 00).</p> <p>b. Notify DS maintenance if parking brake assembly is damaged.</p> <p>Adjust parking brake pad clearance (WP 0122 00).</p> <p>a. Remove any obstructions.</p> <p>b. Replace damaged parking brake control lever (WP 0124 00).</p> <p>a. Tighten loose connections.</p> <p>b. Replace damaged or leaking lines and hoses (WP 0125 00).</p>

Table 4. Steering System Troubleshooting Procedures (Non-Error Code).

MALFUNCTION	TEST OR INSPECTION	CORRECTIVE ACTION
<p>Steering Control is Poor or Nonexistent.</p>	<ol style="list-style-type: none"> 1. Check for any active steering error code(s). 2. Check the steering system dump valve located behind the cab. 3. Inspect steering system components, lines, hoses, and cylinders for damage, leaks, or obstructions. 4. Check for proper operation. Enter into "EXTRA FUNCT" 2(13) in the diagnostic menu. Operate the pump cutoff function and observe any change in engine sound. 5. Check steering system hydraulic pressures at test points 3, 6, and 7 (WP 0188 00 00). 	<p>Perform troubleshooting for active error code(s) (WP 0006 00).</p> <p>Close steering system dump valve (WP 0164 00).</p> <ol style="list-style-type: none"> a. Remove any obstructions. b. Replace any damaged lines, hoses, or fittings, and tighten loose connections (WP 0134 00). c. Replace any damaged or leaking steering cylinder (WP 0135 00). <p>If no notable change is heard or felt while turning the pumps on and off, perform troubleshooting procedure for the 611 valve hydraulic/electrical circuit (WP 0048 00-8 and WP 0048 00-50).</p> <ol style="list-style-type: none"> a. Compare the hydraulic pressures of the test points. All three should be the same 430 to 3,045 psi (2,965 to 20,995 kPa). b. If pressures are not as specified, replace steering/tophandler pump assembly (WP 0242 00).

Table 5. Operator's Cab Troubleshooting Procedures (Non-Error Code).

MALFUNCTION	TEST OR INSPECTION	CORRECTIVE ACTION
<p>Operator's Cab Will Not Move To or From Transport Position Properly.</p>	<ol style="list-style-type: none"> 1. Check auxiliary pump for proper operation (TM 10-3930-675-10). 2. Check cab lift slide rails, rollers, and cab transport lift for damage or obstructions. 3. Inspect cab lift and sideshift cylinders, hoses, and cab transport control valve for damage or leakage. 4. Check for proper operation. Use (WP 0188 00 00) test point 10 to check auxiliary pump pressure. Ensure the supply valve on the hydraulic tank for the auxiliary pump is open. 	<p>If auxiliary pump does not work, use the troubleshooting procedure "<i>Auxiliary Pump Not Working</i>" in this work package to correct the problem.</p> <ol style="list-style-type: none"> a. Repair or replace damaged cab lift slide rails, rollers, or cab transport lift (WP 0138 00). b. Remove obstructions and clean as required. a. Replace any damaged or leaking cylinder (WP 0173 00 and WP 0174 00). b. Replace damaged hoses and tighten loose fittings (WP 0179 00). c. Replace damaged or leaking cab transport control valve (WP 0170 00). a. Open supply valve (FO-10). b. Pump pressure should be around 750 psi (5,171 kPa) no load and 1,595 psi (10,997 kPa) while holding control at full LIFT position. If pressure is not as specified, replace auxiliary pump (WP 0165 00).

Table 6. Auxiliary Pump Troubleshooting Procedures (Non-Error Code).

MALFUNCTION	TEST OR INSPECTION	CORRECTIVE ACTION
<p>Auxiliary Pump Not Working.</p>	<ol style="list-style-type: none"> 1. Check circuit breaker F17 for trip. 2. Inspect auxiliary pump for damage. 3. Inspect and check operation of auxiliary pump switch. 4. Check for proper operation. Enter "EXTRA FUNC" 3(13) in the diagnostic menu. Press the auxiliary pump switch. 5. Check voltage (24V) at X67 pin 1 and 2 while pressing the auxiliary pump switch. 	<ol style="list-style-type: none"> a. Reset circuit breaker as required. b. If breaker does not reset, use the wiring diagram to check circuit for short to ground (WP 0048 00-46 and WP 0048 00-47). Replace any shorted or grounded harnesses (WP 0113 00). c. Replace damaged or faulty circuit breaker (WP 0074 00 00). <p>Replace damaged auxiliary pump (WP 0165 00).</p> <p>Replace damaged or inoperable switch (WP 0073 00).</p> <p>Should have a "1" for INPUT then a "1" for OUTPUT.</p> <ol style="list-style-type: none"> a. If no "1" for INPUT, continue with step 5. b. If no "1" for OUTPUT, replace ECU 792 (WP 0080 00). c. If "1" for OUTPUT, continue with step 7. <ol style="list-style-type: none"> a. If no voltage (24V) is found at X67 pin 1, check circuit breaker F17 and continuity of wires A678 and A671 (WP 0048 00-46). b. If no voltage (24V) is found at X67 pin 2, remove auxiliary pump switch and check for damage and continuity, and check continuity of wires 671 and 672 (WP 0048 00-47). c. Replace damaged or faulty switch (WP 0073 00). d. Repair or replace damaged wires or connectors (WP 0113 00).

Table 6. Auxiliary Pump Troubleshooting Procedures (Non-Error Code) - Continued.

MALFUNCTION	TEST OR INSPECTION	CORRECTIVE ACTION
<p>Auxiliary Pump Not Working - Continued.</p>	<p>6. Check voltage at ECU 792 pin 48 while pressing the auxiliary pump switch.</p> <p>7. Check voltage (24V) at 350-1 solenoid located on top of the auxiliary pump motor. Should have voltage (24V) at the large terminal with the cable (W30) connected to it.</p> <p>8. Press the auxiliary pump switch and check voltage (24V) between motor +terminal and motor ground terminal.</p> <p>9. Check voltage (24V) at 350-1 solenoid pin 86 (top spade terminal) while pressing the auxiliary pump switch. Check ground connections (bottom spade terminal) of solenoid and motor.</p>	<p>a. If no voltage (24V) is found at ECU 792 pin 48, check continuity of wires A474, 474, and A1744 (WP 0048 00-47).</p> <p>b. Repair or replace damaged wires or connectors (WP 0113 00).</p> <p>a. If no voltage (24V) is found, check voltage (24V) at the circuit breakers (F51-1 and FS1-2) mounted under the auxiliary pump (WP 0048 00-33 and WP 0048 00-47).</p> <p>b. Replace damaged or faulty circuit breakers (WP 0074 00).</p> <p>c. Repair or replace damaged wires or connectors (WP 0113 00).</p> <p>a. If no voltage (24V) is found, test 350-1 solenoid (WP 0113 00).</p> <p>b. If 350-1 solenoid damaged or faulty, replace auxiliary pump (WP 0165 00).</p> <p>c. If voltage (24V) is found, replace auxiliary pump (WP 0165 00).</p> <p>d. Repair loose or disconnected ground cables (WP 0048 00-47).</p> <p>a. If no voltage (24V) is found at 350-1 pin 86, remove relay 350 and test (WP 0113 00 and WP 0048 00-47).</p> <p>b. Replace damaged or faulty relay (WP 0074 00).</p> <p>c. Check continuity of wires 251, 252, A251, A251A, and A671A (WP 0048 00-47).</p> <p>d. Repair or replace damaged wires or connectors (WP 0113 00).</p>

Table 6. Auxiliary Pump Troubleshooting Procedures (Non-Error Code) - Continued.

MALFUNCTION	TEST OR INSPECTION	CORRECTIVE ACTION
<p>Auxiliary Pump Not Working - Continued.</p>	<p>10. Check voltage (24V) at XK3 pin 8 while pressing the auxiliary pump switch.</p>	<p>a. If no voltage (24V) is found at XK3 pin 8, check continuity of wires A469, 469, and A1745 (WP 0048 00-47).</p> <p>b. Check wire connection and voltage (24V with switch pressed) at ECU 792 pin 61 (WP 0048 00-47).</p> <p>c. Repair or replace damaged wires or connectors (WP 0113 00).</p>

Table 7. Boom System Troubleshooting Procedures (Non-Error Code).

MALFUNCTION	TEST OR INSPECTION	CORRECTIVE ACTION
<p>1. Boom Will Not Lift or Lower Properly.</p>	<ol style="list-style-type: none"> 1. Check for active boom system error code(s) (WP 0005 00). 2. Check hydraulic oil level. Ensure hydraulic oil level is within operating range (WP 0051 00). 3. Ensure boom locked (red) twistlock indicator light is on. 4. Inspect lift cylinders for obstructions, damage, and signs of leakage. 5. Check lift cylinder hydraulic lines and hoses for damage and signs of leakage. 6. Ensure lift cylinder emergency and float valves are in closed position. 7. Check boom and tophandler calibration (WP 0259 00). 8. Check test boom control system. Operate the auxiliary pump using the procedure "Lower Boom (Extended or Loaded with a Container)" (TM 10-3930-675-10) to test boom control system. (The boom movements will be extremely slow). 9. Test boom system operating pressures at test points 8 and 9 (WP 0188 00). 	<p>Perform troubleshooting procedures to clear error code(s) (WP 0005 00).</p> <p>Fill hydraulic oil as required (WP 0050 00).</p> <p>Use the override switch to move twistlocks into proper position (TM 10-3930-675-10).</p> <ol style="list-style-type: none"> a. Remove any obstructions. b. Replace damaged or leaking cylinders (WP 0252 00). a. Tighten loose connections. b. Replace damaged or leaking lines and hoses (WP 0182 00). <p>Close emergency and float valves as required (TM 10-3930-675-10).</p> <p>Calibrate boom and tophandler as required (WP 0259 00).</p> <ol style="list-style-type: none"> a. If boom system operates normally, the boom control system is not at fault, check boom and brake pump pressure (WP 0188 00). b. If boom system does not operate normally, check boom control system. a. If test point 9 pressure is not normal, replace servo pressure reducing valve first, then the servo control valve (WP 0250 00) if needed. b. If boom will extend and retract normally, but not lift or lower, replace the main control valve assembly (WP 0249 00).

Table 7. Boom System Troubleshooting Procedures (Non-Error Code) - Continued.

MALFUNCTION	TEST OR INSPECTION	CORRECTIVE ACTION
<p>1. Boom Will Not Lift or Lower Properly - Continued.</p> <p>2. Boom Will Not Extend or Retract Properly.</p>	<p>1. Check for active boom system error code(s) (WP 0005 00).</p> <p>2. Ensure hydraulic oil level is within operating range (WP 0050 00).</p> <p style="text-align: center;">NOTE</p> <p style="text-align: center;">Extension cylinder leaks appear to be coming from inside boom assembly.</p> <p>3. Inspect extension cylinder for damage and signs of leakage.</p> <p>4. Check extension cylinder hydraulic lines and hoses for damage and signs of leakage.</p> <p>5. Check boom wear plates for wear or damage.</p> <p>6. Check boom and tophandler calibration (WP 0259 00).</p> <p>7. Test boom control system. Operate the auxiliary pump using the procedure “Lower boom (Extended or Loaded with a Container)” (TM 10-3930-675-10) to test boom control system. (The boom movements will be extremely slow).</p> <p>8. Test boom system operating pressures, test points 8 and 9 (WP 0188 00).</p>	<p>c. If test point 8 pressure is not normal, replace boom and brake system hydraulic pump (WP 0246 00).</p> <p>Perform troubleshooting procedures to clear error code(s) (WP 0006 00).</p> <p>Fill hydraulic oil as required (WP 0050 00).</p> <p>Notify SRA to replace damaged or leaking extension cylinder.</p> <p>a. Tighten loose connections. b. Replace damaged or leaking lines and hoses (WP 0182 00).</p> <p>Replace worn or damaged boom wear plates (WP 0146 00).</p> <p>Calibrate boom and tophandler as required (WP 0259 00).</p> <p>a. If boom system operates normally, the boom control system is not at fault, check boom and brake pump pressure (WP 0188 00). b. If boom system does not operate normally, check boom control system.</p> <p>a. If test point 9 pressure is not normal, replace servo pressure reducing valve first, then the servo control valve (WP 0250 00) if needed.</p>

Table 7. Boom System Troubleshooting Procedures (Non-Error Code) - Continued.

MALFUNCTION	TEST OR INSPECTION	CORRECTIVE ACTION
<p>2. Boom Will Not Extend or Retract Properly - Continued.</p> <p>3. Boom Folding Cylinders Not Working.</p>	<p>1. Check operation of all tophandler functions.</p> <p>2. Check clearance of cab proximity switch (7210) between cab and frame. Move the cab to the transport position (TM 10-3930-675-10).</p> <p style="text-align: center;">NOTE</p> <p>DO NOT adjust proximity switch (7210) beyond end of enclosure.</p> <p>3. Inspect boom folding control valve for damage and signs of leakage. Pull back on the bogie wheel lever and check if bogie wheel will lift off the locking collar.</p> <p>4. Check cab proximity switch (7210) and solenoid valve (6043) operation and wiring (WP 0048 00-30).</p>	<p>b. If boom will extend and retract normally, but not lift or lower, replace the main control valve assembly (WP 0249 00).</p> <p>c. If test point 8 pressure is not normal, replace boom and brake system hydraulic pump (WP 0246 00).</p> <p>a. If no tophandler functions operate, check tophandler pump pressure at test point no. 11 (WP 0188 00).</p> <p>b. Troubleshooting pump control circuit (611 solenoid) (WP 0048 00-8 and WP 0048 00-50).</p> <p>c. Replace steering and tophandler pump assembly (WP 0242 00).</p> <p>Move cab closer to the frame. Adjust cab or proximity switch (7210) to correct clearance.</p> <p>Replace damaged or leaking boom folding control valve(s) (WP 0172 00).</p> <p>a. Replace damaged or inoperative proximity switch (WP 0076 00).</p> <p>b. Replace damaged or faulty solenoid valve (WP 0171 00).</p>

Table 7. Boom System Troubleshooting Procedures (Non-Error Code) - Continued.

MALFUNCTION	TEST OR INSPECTION	CORRECTIVE ACTION
<p>3. Boom Folding Cylinders Not Working - Continued.</p>	<p>5. Inspect boom folding cylinders and hydraulic lines and hoses and boom folding control valve for damage and signs of leakage.</p>	<p>a. Tighten loose connections. b. Replace damaged or leaking lines and hoses (WP 0181 00). c. Replace damaged or leaking boom folding control valve (WP 0172 00). d. Replace damaged or leaking boom folding cylinder(s) (WP 0253 00). e. Replace the over-center valve (WP 0182 00).</p>
<p>4. Boom Locking Pin Cylinders Not Working.</p>	<p>1. Check operation of all tophandler functions.</p> <p>2. Check clearance of cab proximity switch (7210) between cab and frame. Move the cab to the transport position (TM 10-3930-675-10).</p> <p>3. Inspect boom folding control valve for damage and signs of leakage. Pull back on the bogie wheel lever and check if bogie wheel will lift off the locking collar.</p>	<p>a. If no tophandler functions operate, check tophandler pump pressure at test point no. 11 (WP 0188 00). b. Troubleshoot pump control circuit (611 solenoid) (WP 0048 00-8 and WP 0048 00-50). c. Replace steering and tophandler pump assembly (WP 0242 00).</p> <p style="text-align: center;">NOTE</p> <p style="text-align: center;">Raise boom folding cylinders to release pressure on locking pins before operating locking pin cylinders.</p> <p>Move cab closer to the frame. Adjust cab or proximity switch (7210) to correct clearance.</p> <p>Replace damaged or leaking boom folding control valve(s) (WP 0172 00).</p> <p style="text-align: center;">NOTE</p> <p style="text-align: center;">DO NOT adjust proximity switch (7210) beyond end of enclosure.</p>

Table 7. Boom System Troubleshooting Procedures (Non-Error Code) - Continued.

MALFUNCTION	TEST OR INSPECTION	CORRECTIVE ACTION
<p>4. Boom Locking Pin Cylinders Not Working - Continued.</p>	<p>4. Check cab proximity switch (7210) and solenoid valve (6043) operation and wiring (WP 0048 00-30).</p> <p>5. Inspect locking pin cylinders and hydraulic line and hoses for damage and signs of leakage.</p> <p>6. Inspect locking pins for damage.</p> <p>7. Inspect double pilot operated check valve mounted on the locking pin cylinder for damage or leaking.</p>	<p>a. Replace damaged or inoperative proximity switch (WP 0076 00).</p> <p>b. Replace damaged or faulty solenoid valve (WP 0171 00).</p> <p>a. Tighten loose connections.</p> <p>b. Replace damaged or leaking lines and hoses (WP 0178 00).</p> <p>c. Replace damaged or leaking locking pin cylinder(s) (WP 0254 00).</p> <p>Check for frame or boom support damage.</p> <p>Replace double pilot operated check valve (WP 0182 00).</p>

Table 8. Tophandler System Troubleshooting Procedures (Non-Error Code).

MALFUNCTION	TEST OR INSPECTION	CORRECTIVE ACTION
<p>1. Tophandler Will Not Tilt Forward or Rearward Properly.</p>	<p>1. Check for any active tophandler error code(s).</p> <p>2. Check operation of all tophandler functions.</p> <p>3. Inspect tophandler control valve, lines, hoses, and tilt cylinders for damage, leaks, or obstructions. Check the tophandler hose quick-disconnect fittings for connection.</p> <p>4. Check tophandler control valve solenoids 6010 and 6011 for damage or leaking.</p>	<p>Perform troubleshooting for active error code(s) (WP 0005 00).</p> <p>a. If no tophandler functions operate, check tophandler pump pressure at test point 11 (WP 0188 00).</p> <p>b. Troubleshoot pump control circuit (611 solenoid) (WP 0048 00-8 and WP 0048 00-50).</p> <p>c. Replace steering and tophandler pump assembly (WP 0242 00).</p> <p>a. Remove any obstructions.</p> <p>b. Replace any damaged line, hoses, or fittings, and tighten loose connections (WP 0183 00).</p> <p>c. Connect any disconnected quick-disconnect fittings (WP 0188 00).</p> <p>d. Replace damaged or leaking tilt cylinder (WP 0255 00).</p> <p>Replace damaged or leaking solenoid (WP 0171 00).</p> <p style="text-align: center;">WARNING</p> <p style="text-align: center;">Injury or death can occur during manual operation of the hydraulic function.</p> <p style="text-align: center;">CAUTION</p> <p style="text-align: center;">Be careful not to lose the small orifice plug inside the solenoid valve body when removing the solenoid.</p>

Table 8. Tophandler System Troubleshooting Procedures (Non-Error Code) - Continued.

MALFUNCTION	TEST OR INSPECTION	CORRECTIVE ACTION
<p>1. Tophandler Will Not Tilt Forward or Rearward Properly - Continued.</p>	<p>5. Check for proper operation. Start the engine (TM 10-3930-675-10). Disconnect the connector from the 6010 and 6011 solenoids. Locate the small brass button between the two connector pins on the solenoid. Use a jeweler's screwdriver to press the button momentarily to manually activate the tilt function. Check both solenoids the same way.</p>	<p>a. Replace damaged or faulty solenoid (WP 0171 00). b. Replace the tilt-over cylinder valve.</p>
<p>2. Tophandler Will Not Oscillate (Level) Properly.</p>	<p>1. Check for any active tophandler error code(s).</p> <p>2. Check operation of all tophandler functions.</p> <p>3. Inspect tophandler control valve, lines, hoses, and oscillation cylinders for damage, leaks, or obstructions. Check the tophandler hose quick-disconnect fittings for connection.</p> <p>4. Inspect oscillation wear plates for damage and wear.</p> <p>5. Check tophandler control valve solenoids 6035 and 6036 for damage or leaking.</p>	<p>Perform troubleshooting for active error code(s) (WP 0005 00).</p> <p>a. If no tophandler functions operate, check tophandler pump pressure at test point 11 (WP 0188 00). b. Troubleshoot pump control circuit (611 solenoid) (WP 0048 00-8 and WP 0048 00-50). c. Replace steering and tophandler pump assembly (WP 0242 00). d. Replace damaged or leaking oscillation cylinder or tophandler control valve (WP 0251 00).</p> <p>a. Remove any obstructions. b. Replace any damaged line, hoses, or fittings, and tighten loose connections (WP 0183 00). c. Connect any disconnected quick-disconnect fittings (WP 0183 00). d. Replace damaged or leaking oscillation cylinder or tophandler control valve (WP 0251 00).</p> <p>Replace any worn or damaged wear plates (WP 0147 00).</p> <p>Replace damaged or leaking solenoid (WP 0171 00).</p>

Table 8. Tophandler System Troubleshooting Procedures (Non-Error Code) - Continued.

MALFUNCTION	TEST OR INSPECTION	CORRECTIVE ACTION
<p>2. Tophandler Will Not Oscillate (Level) Properly - Continued.</p>	<p style="text-align: center;">WARNING</p> <p style="text-align: center;">Injury or death can occur during manual operation of the hydraulic function.</p> <p>6. Check for proper operation. Start the engine (TM 10-3930-675-10). Disconnect the connector from the 6035 and 6036 solenoids. Locate the small brass button between the two connector pins on the solenoid. Use a jeweler's screwdriver to press the button momentarily to manually activate the oscillate function. Check both solenoids the same way.</p>	
<p>3. Tophandler Will Not Sideshift Properly.</p>	<p>1. Check for any active tophandler error code(s). 2. Check operation of all tophandler functions. 3. Inspect tophandler control valve, lines, hoses, and sideshift cylinders for damage, leaks, or obstructions. Check the tophandler hose quick-disconnect fittings for connections.</p>	
		<p>a. If the function does not activate, remove the solenoid and inspect (WP 0171 00). b. Replace damaged or faulty solenoid (WP 0171 00). c. Replace the oscillate over-center valve.</p> <p>Perform troubleshooting for active error code(s) (WP 0005 00).</p> <p>a. If no tophandler functions operate, check tophandler pump pressure at test point 11 (WP 0188 00). b. Troubleshoot pump control circuit (611 solenoid) (WP 0048 00-8 and WP 0048 00-50). c. Replace steering and tophandler pump assembly (WP 0242 00). a. Remove any obstructions. b. Replace any damaged line, hoses, or fittings, and tighten loose connections (WP 0183 00). c. Connect any disconnected quick-disconnect fittings (WP 0183 00). d. Replace damaged or leaking sideshift cylinder (WP 0256 00) or tophandler control valve (WP 0251 00).</p>

Table 8. Tophandler System Troubleshooting Procedures (Non-Error Code) - Continued.

MALFUNCTION	TEST OR INSPECTION	CORRECTIVE ACTION
<p>3. Tophandler Will Not Sideshift Properly - Continued.</p>	<p>4. Inspect sideshift wear plates for damage or wear.</p> <p>5. Check tophandler control valve solenoids 6020 and 6021 for damage or leaking.</p> <p style="text-align: center;">WARNING</p> <p style="text-align: center;">Injury or death can occur during manual operation of the hydraulic function.</p> <p style="text-align: center;">CAUTION</p> <p style="text-align: center;">Be careful not to lose the small orifice plug inside the solenoid valve body when removing the solenoid.</p> <p>6. Check for proper operation. Start the engine (TM 10-3930-675-10). Disconnect the connector from the 6020 and 6021 solenoids. Locate the small brass button between the two connector pins on the solenoid. Use a jeweler's screwdriver to press the button momentarily to manually activate the sideshift function. Check both solenoids the same way.</p>	<p>Replace any worn or damaged wear plates (WP 0147 00).</p> <p>Replace damaged or leaking solenoid (WP 0171 00).</p> <p>Replace damaged or faulty solenoid (WP 0171 00).</p>
<p>4. Tophandler Spreader Will Not Open or Close Properly.</p>	<p>1. Check for any active tophandler error code(s).</p> <p>2. Check operation of all tophandler functions.</p>	<p>Perform troubleshooting for active error code(s) (WP 0005 00).</p> <p>a. If no tophandler functions operate, check tophandler pump pressure at test point 11 (WP 0188 00).</p> <p>b. Troubleshoot pump control circuit (611 solenoid) (WP 0048 00-8 and WP 0048 00-50).</p> <p>c. Replace steering and tophandler pump assembly (WP 0242 00).</p>

Table 8. Tophandler System Troubleshooting Procedures (Non-Error Code) - Continued.

MALFUNCTION	TEST OR INSPECTION	CORRECTIVE ACTION
<p>4. Tophandler Spreader Will Not Open or Close Properly - Continued.</p>	<p>3. Check position of twistlocks. The spread will not operate when the twistlocks are not in the UNLOCKED position.</p> <p>4. Check operation of the forklift kit proximity switches and cam mechanism.</p> <p>5. Inspect lines, hoses, and spreader motor for damage, leaks, or obstructions. Check the tophandler hose quick-disconnect fittings for connection.</p> <p>6. Inspect both spreader chains and sprockets for damage, wear, tightness, or obstructions.</p> <p>7. Inspect spreader wear plates for damage or wear.</p> <p>8. Check tophandler control valve solenoids 6018 and 6019 for damage or leaking.</p> <p style="text-align: center;">WARNING</p> <p style="text-align: center;">Injury or death can occur during manual operation of the hydraulic function.</p> <p style="text-align: center;">CAUTION</p> <p style="text-align: center;">Be careful not to lose the small orifice plug inside the solenoid valve body when removing the solenoid.</p>	<p>Place twistlocks in the UNLOCKED position. If twistlocks do not operate, ensure cab is in operational position.</p> <p>Ensure both proximity switches are activated and cam mechanism operates properly.</p> <p>a. Remove any obstructions. b. Replace any damaged line, hoses, or fittings, and tighten loose connections (WP 0183 00). c. Connect any disconnected quick-disconnect fittings (WP 0183 00). d. Replace damaged or leaking spreader motor (WP 0167 00).</p> <p>Replace or adjust damaged, worn, or loose spreader chains (WP 0168 00).</p> <p>Replace any worn or damaged wear plates (WP 0147 00).</p> <p>Replace damaged or leaking solenoid (WP 0171 00).</p>

Table 8. Tophandler System Troubleshooting Procedures (Non-Error Code) - Continued.

MALFUNCTION	TEST OR INSPECTION	CORRECTIVE ACTION
<p>4. Tophandler Spreader Will Not Open or Close Properly - Continued.</p>	<p>9. Check for proper operation. Start the engine (TM 10-3930-675-10). Disconnect the connector from the 6018 and 6019 solenoids. Locate the small brass button between the two connector pins on the solenoid. Use a jeweler's screwdriver to press the button momentarily to manually activate the spreader function. Check both solenoids the same way.</p>	<p>a. Replace damaged or faulty solenoid (WP 0171 00). b. Replace the spreader motor over-center valve (WP 0167 00). c. Replace spreader motor assembly (WP 0167 00).</p>
<p>5. Tophandler Will Not Rotate Left or Right Properly.</p>	<p>1. Check for any active tophandler error code(s).</p> <p>2. Check operation of all tophandler functions.</p> <p>3. Inspect tophandler control valve, lines, hoses, and slewing motors for damage, leaks, or obstructions. Check the tophandler hose quick-disconnect fittings for connections.</p>	<p>Perform troubleshooting for active error code(s) (WP 0005 00).</p> <p>a. If no tophandler functions operate, check tophandler pump pressure at test point 11 (WP 0188 00). b. Troubleshoot pump control circuit (611 solenoid) (WP 0048 00-8 and WP 0048 00-50). c. Replace steering and tophandler pump assembly (WP 0242 00).</p> <p>a. Remove any obstructions. b. Replace any damaged line, hoses, or fittings, and tighten loose connections (WP 0183 00). c. Connect any disconnected quick-disconnect fittings (WP 0183 00). d. Replace damaged or leaking slewing motor (WP 0166 00).</p>

Table 8. Tophandler System Troubleshooting Procedures (Non-Error Code) - Continued.

MALFUNCTION	TEST OR INSPECTION	CORRECTIVE ACTION
<p>5. Tophandler Will Not Rotate Left or Right Properly - Continued.</p>	<p>4. Remove the slewing gear covers and inspect slewing gear and pinions for damage, wear, or obstructions.</p> <p>5. Check tophandler control valve solenoids 6008 and 6009 for damage or leaking.</p>	<p>a. Replace any worn or damaged slewing motor and pinion (WP 0166 00).</p> <p>b. Replace damaged or worn slewing gear (WP 0244 00).</p> <p>Replace damaged or leaking solenoid (WP 0171 00).</p> <p style="text-align: center;">WARNING</p> <p style="text-align: center;">Injury or death can occur during manual operation of the hydraulic function.</p> <p style="text-align: center;">CAUTION</p> <p style="text-align: center;">Be careful not to lose the small orifice plug inside the solenoid valve body when removing the solenoid.</p> <p>6. Check for proper operation. Start the engine (TM 10-3930-675-10). Disconnect the connector from the 6008 and 6009 solenoids. Locate the small brass button between the two connector pins on the solenoid. Use a jeweler's screwdriver to press the button momentarily to manually activate the rotate function. Check both solenoids the same way.</p>
<p>6. Tophandler Twistlocks Will Not Rotate Properly.</p>	<p>1. Check for any active tophandler error code(s).</p>	<p>a. If the function does not activate, remove the solenoid and inspect (WP 0171 00).</p> <p>b. Replace damaged or faulty solenoid (WP 0171 00).</p> <p>c. Replace the slewing motor over-center valve (WP 0166 00).</p> <p>d. Replace slewing motor assembly (WP 0166 00).</p> <p>Perform troubleshooting for active error code(s) (WP 0006 00).</p>

Table 8. Tophandler System Troubleshooting Procedures (Non-Error Code) - Continued.

MALFUNCTION	TEST OR INSPECTION	CORRECTIVE ACTION
<p>6. Tophandler Twistlocks Will Not Rotate Properly - Continued.</p>	<p>2. Check operation of all tophandler functions.</p> <p>3. Check position of cab. Twistlocks will not operate when the cab is not in the operational position.</p> <p>4. Check position of twistlock cylinder bypass valves. With tophandler in operational position, left side valve points forward and right side valve points back.</p> <p>5. Inspect bypass valves, lines, hoses, and twistlock cylinders for damage, leaks, or obstructions. Check the tophandler hose quick-disconnect fittings for connection.</p> <p>6. Inspect twistlocks and linkage arms for damage or obstructions.</p> <p>7. Check tophandler control valve solenoids 6039 and 6040 for damage or leaking.</p>	<p>a. If no tophandler functions operate, check tophandler pump pressure at test point 11 (WP 0188 00).</p> <p>b. Troubleshoot pump control circuit (611 solenoid) (WP 0048 00-8 and WP 0048 00-50).</p> <p>c. Replace steering and tophandler pump assembly (WP 0242 00).</p> <p>Place cab in operational position (TM 10-3930-675-10).</p> <p>Place both valves in proper position.</p> <p>a. Remove any obstructions.</p> <p>b. Replace any damaged bypass valve line, hoses, or fittings, and tighten loose connections (WP 0183 00).</p> <p>c. Connect any disconnected quick-disconnect fittings (WP 0183 00).</p> <p>d. Replace damaged or leaking twistlock cylinder (WP 0175 00).</p> <p>a. Remove obstructions.</p> <p>b. Replace damaged twistlock or linkage (WP 0260 00).</p> <p>c. Replace damaged or leaking solenoid (WP 0171 00).</p>

Table 8. Tophandler System Troubleshooting Procedures (Non-Error Code) - Continued.

MALFUNCTION	TEST OR INSPECTION	CORRECTIVE ACTION
<p>6. Tophandler Twistlocks Will Not Rotate Properly - Continued.</p>	<p style="text-align: center;">WARNING</p> <p>Injury or death can occur during manual operation of the hydraulic function.</p> <p style="text-align: center;">CAUTION</p> <p>Be careful not to lose the small orifice plug inside the solenoid valve body when removing the solenoid.</p> <p>8. Check for proper operation. Start the engine (TM 10-3930-675-10). Disconnect the connector from the 6039 and 6040 solenoids. Locate the small brass button between the two connector pins on the solenoid. Use a jeweler's screwdriver to press the button momentarily to manually activate the twistlock function. Check both solenoids the same way.</p>	<p>a. If the function does not activate, remove the solenoid and inspect (WP 0171 00).</p> <p>b. Replace damaged or faulty solenoid (WP 0171 00).</p> <p>c. Replace twistlock double pilot operated check valve (WP 0175 00).</p>

Table 9. Bogie Wheel System Troubleshooting Procedures (Non-Error Code).

MALFUNCTION	TEST OR INSPECTION	CORRECTIVE ACTION
<p>Bogie Wheels Will Not Lift or Lower.</p>	<ol style="list-style-type: none"> 1. Check operation of all tophandler functions. 2. Check clearance of cab proximity switch (7210) between cab and frame. Move the cab to the transport position (TM 10-3930-675-10). 3. Inspect bogie wheel slide rails and locking collar/bogie screw for obstructions. 4. Check position of bogie pressure valve. 5. Inspect boom folding control valve for damage and signs of leakage. 6. Check cab proximity switch (7210) and solenoid valve (6043) operation and wiring (WP 0048 00-30). 7. Inspect bogie wheel cylinders and hydraulic lines and hoses and boom folding control valve for damage and signs of leakage. 	<ol style="list-style-type: none"> a. If no tophandler functions operate, check tophandler pump pressure at test point 11 (WP 0188 00). b. Troubleshoot pump control circuit (611 solenoid) (WP 0048 00-8 and WP 0048 00-50). c. Replace steering and tophandler pump assembly (WP 0242 00). <p>Move cab closer to the frame. Adjust cab or proximity switch (7210) to correct clearance.</p> <p style="text-align: center;">NOTE</p> <p style="text-align: center;">DO NOT adjust proximity switch (7210) beyond end of enclosure.</p> <ol style="list-style-type: none"> Remove obstructions and clean as required. Place bogie pressure valve in the CLOSED position (TM 10-3930-675-10). Replace damaged or leaking boom folding control valve(s) (WP 0172 00). a. Replace damaged or inoperative proximity switch (WP 0076 00). b. Replace damaged or faulty solenoid valve (WP 0171 00). a. Tighten loose connections. b. Replace damaged or leaking lines and hoses (WP 0182 00). c. Replace damaged or leaking boom folding control valve (WP 0172 00).

Table 9. Bogie Wheel System Troubleshooting Procedures (Non-Error Code) - Continued.

MALFUNCTION	TEST OR INSPECTION	CORRECTIVE ACTION
Bogie Wheels Will Not Lift or Lower - Continued.		d. Replace damaged or leaking bogie wheel cylinder(s) (WP 0233 00). e. Replace the over-center valve (WP 0182 00).

Table 10. Forklift Kit Troubleshooting Procedures (Non-Error Code).

MALFUNCTION	TEST OR INSPECTION	CORRECTIVE ACTION
Fork Functions Not Working Properly.	1. Check for any active tophandler error code(s). 2. Check operation of all tophandler functions. 3. Check operation of the forklift kit proximity switches and cam mechanism. 4. Inspect lines, hoses, and cylinders for damage or leaks. Check the tophandler hose quick-disconnect fittings for connection. 5. Inspect fork wear plates and shaft sliding surfaces for damage, wear, or obstructions. 6. Inspect forklift hydraulic valves for damage or leaking.	Perform troubleshooting for active error code(s) (WP 0005 00). a. If no tophandler functions operate, check tophandler pump pressure at test point 11 (WP 0188 00). b. Troubleshoot pump control circuit (611 solenoid) (WP 0048 00-8 and WP 0048 00-50). c. Replace steering and tophandler pump assembly (WP 0242 00). Ensure both proximity switches are active and cam mechanism operates properly. a. Replace any damaged line, hoses, or fittings, and tighten loose connections (WP 0183 00). b. Connect any disconnected quick-disconnect fittings (WP 0183 00). c. Replace damaged or leaking cylinder (WP 0261 00). a. Remove any obstructions. b. Replace any worn or damaged wear plates. Replace any damaged or leaking hydraulic valves (WP 0184 00).

**Table 11. Autolube System Not Lubricating Properly (USMC Only)
Troubleshooting Procedures (Non-Error Code).**

MALFUNCTION	TEST OR INSPECTION	CORRECTIVE ACTION
<p>Autolube System Not Lubricating Properly (USMC Only).</p>	<ol style="list-style-type: none"> 1. Ensure Autolube reservoir is filled above 1/4 or more and lubricant is of proper type. 2. Check operation of Autolube pump. 3. Locate the main distribution valve located in the storage compartment under the batteries. Inspect for damage and operation. 4. Check all of the Autolube system lubrication points for signs of lubrication emerging. A lube point with no signs of lubrication over a period of several lube cycles may indicate a “plugged” lube point. 5. Check for lubricant leaking from pressure limiting valve located on the side of the pump assembly. 6. Use the Autolube tubing layout diagram (WP 0048 00-55) to trace the identified tube to the secondary distribution valve. 	<p>Consult the Lubrication Instruction (WP 0050 00) for lubricant type and filling instructions.</p> <ol style="list-style-type: none"> a. Initiate a manual pump cycle (WP 0050 00). b. Perform troubleshooting procedure for “<i>Autolube Pump Not Working (USMC Only)</i>” in this work package. a. Observe if the pin is moving in and out during a manual cycle. b. Replace damaged main distribution valve. a. At any suspected lube point; remove the Autolube tubing and fitting. Install a grease fitting (part #160) and try to manually lubricate with a grease gun. b. Repair any “plugged” lube point and reinstall the Autolube fitting and tubing. a. Disconnect each outlet tube one at a time at the main distribution valve. b. Identify the tube that had pressure on it when disconnected. c. Reconnect the tubes and run a manual lube cycle. a. Disconnect each outlet tube at the secondary distribution valve one at a time until you identify the one with pressure on it. b. Use the tubing layout diagram to trace the identified tube to the “plugged” lube point.

**Table 11. Autolube System Not Lubricating Properly (USMC Only)
Troubleshooting Procedures (Non-Error Code) - Continued.**

MALFUNCTION	TEST OR INSPECTION	CORRECTIVE ACTION
<p>Autolube System Not Lubricating Properly (USMC Only) - Continued.</p>	<p>7. At the “plugged” lube point, remove the Autolube tubing and fitting. Install a grease fitting (part #160) and try to manually lubricate with a grease gun.</p> <p>8. If no “plugged” lube points are found, run a manual lube cycle and disconnect the inlet tube at each secondary distribution valve to identify the tube with pressure on it.</p> <p>9. Inspect all Autolube system tubing and fittings for damage or wear.</p>	<p>a. Repair the “plugged” lube point and reinstall the Autolube fitting and tubing.</p> <p>b. Run a manual lube cycle to test the “plugged” lube point repair.</p> <p>Replace non-functioning or “plugged” secondary distribution valve.</p> <p>Replace any damaged or worn tubing or fittings.</p>

**Table 12. Autolube Pump Not Working (USMC Only)
Troubleshooting Procedures (Non-Error Code).**

MALFUNCTION	TEST OR INSPECTION	CORRECTIVE ACTION
<p>Autolube Pump Not Working (USMC Only).</p>	<p>1. Check circuit breaker F34 for trip.</p> <p>2. Inspect Autolube pump for damage.</p> <p>3. Enter “EXTRA FUNC” 10(13) in the diagnostic menu. Use the ± keys to activate pump control circuit. “SET OUTPUT SIG” should be “1” when activated.</p> <p>4. If LED light on Autolube pump printed circuit board is not on, check voltage (24V) at X174B pin 2.</p>	<p>a. Reset circuit breaker as required.</p> <p>b. Replace damaged or faulty circuit breaker (WP 0074 00).</p> <p>Replace damaged Autolube pump.</p> <p>Remove the plastic plug from the front of the Autolube pump. Check if the left LED light on the pump printed circuit board is on. Push the button on the PC board for two seconds to activate a manual cycle.</p> <p>a. If no voltage (24V) is found at X174B pin 2, check connection of wire A174B2 at ECU (792) pin 60.</p> <p>b. Check continuity of wire A174B2.</p> <p>c. Repair or replace damaged wires or connectors (WP 0113 00).</p> <p>d. Replace ECU (792) (WP 0080 00).</p>

**Table 12. Autolube Pump Not Working (USMC Only)
Troubleshooting Procedures (Non-Error Code) - Continued.**

MALFUNCTION	TEST OR INSPECTION	CORRECTIVE ACTION
<p>Autolube Pump Not Working (USMC Only) - Continued.</p>	<p>5. Access the relay boards inside the cab distribution box. Activate the pump control circuit again and check voltage (24V) at XK1 pin 8.</p> <p>6. Remove relay 3018 and test (WP 0113 00).</p> <p>7. Activate the pump control circuit again and check voltage (24V) at XK1 pin 9 and pin 3.</p> <p>8. Activate the pump control circuit again and check voltage (24V) at X31 pin 8.</p> <p>9. Locate the 2-pin connector and harness that leads to the pump assembly in the battery compartment behind the batteries. Unplug the connector and test for voltage (24V) between the two pins of the harness with the pump control circuit activated.</p>	<p>a. If no voltage (24V) is found at XK1 pin 8, check continuity of wires 476 and A476.</p> <p>b. Repair or replace damaged wires or connectors (WP 0113 00).</p> <p>Replace damaged or faulty relay (WP 0074 00).</p> <p>a. If no voltage (24V) is found at XK 1 pin 9, check circuit breaker F34 and continuity of wire A341.</p> <p>b. If no voltage (24V) is found at XK1 pin 3, replace relay 3018.</p> <p>c. Repair or replace damaged wires or connectors (WP 0113 00).</p> <p>a. If no voltage (24V) is found at X31 pin 8, check continuity of wire A318.</p> <p>b. Repair or replace damaged wires or connectors (WP 0113 00).</p> <p>a. If voltage (24V) is present, replace the autolube pump.</p> <p>b. If voltage (24V) is not present, check the continuity of wires GY and BK in the pump harness and the ground connection of wire A319 at 37-1 in the cab distribution box in the cab.</p> <p>c. Replace damaged or open Autolube harness.</p>

**Table 13. Solar Charger Not Working (USMC Only)
Troubleshooting Procedures (Non-Error Code).**

MALFUNCTION	TEST OR INSPECTION	CORRECTIVE ACTION
<p>Solar Charger Not Working (USMC Only).</p>	<ol style="list-style-type: none"> 1. Inspect solar panel and wiring connections for damage and connection. 2. Check for blown 2 amp fuse located in the fuse holder on the RED wire connected to the master switch battery side terminal (WP 0048 00-33). 3. Inspect 24V Pulse module for damage and connection (WP 0048 00-33). Blinking red LED on 24V Pulse module indicates voltage is connected and unit is operating. 	<p>Replace damaged solar panel (WP 0109 00).</p> <p>Replace blown 2 amp fuse (WP 0109 00).</p> <p>Replace damaged/non-functioning 24V Pulse module (WP 0109 00).</p>

END OF WORK PACKAGE

ENGINE FUEL INJECTOR CIRCUITS TROUBLESHOOTING

0008 00

THIS WORK PACKAGE COVERS

- | | |
|--|--|
| Error Code 1311 - Injector Circuit Failure | Error Code 1323 - Injector Circuit Failure |
| Error Code 1312 - Injector Circuit Failure | Error Code 1324 - Injector Circuit Failure |
| Error Code 1313 - Injector Circuit Failure | Error Code 1325 - Injector Circuit Failure |
| Error Code 1314 - Injector Circuit Failure | Error Code 1331 - Injector Circuit Failure |
| Error Code 1315 - Injector Circuit Failure | Error Code 1332 - Injector Circuit Failure |
| Error Code 1321 - Injector Circuit Failure | Error Code 1951 - Injector Circuit Failure |
| Error Code 1322 - Injector Circuit Failure | |

INITIAL SETUP

Tools and Special Tools

- Test Lead, Female (Item 121, WP 0289 00)
- Test Lead, Male (Item 124, WP 0289 00)

References

- TM 10-3930-675-10



WARNING

Injector solenoids receive high voltage when engine is operating. To avoid personal injury or death from electrical shock, do not wear jewelry or damp clothing, and do not touch injector solenoids or solenoid wires when engine is operating.

NOTE

Refer to WP 0004 00 for additional troubleshooting guidance, information, and illustrations that locate critical components.

Table 1. Error Code 1311 - Injector Circuit Failure Troubleshooting Procedures.


MALFUNCTION	TEST OR INSPECTION	CORRECTIVE ACTION
<p>Error Code 1311 - Injector Circuit Failure.</p> 	<p>1. Place ignition switch in OFF position and disconnect actuator harness from engine ECU and from 15-pin connector at front of engine below rocker arm cover.</p> <p>a. Inspect actuator harness, actuator harness connector, and 15-pin connector for dirty, corroded, bent, broken, pushed back, and extended pins.</p>	<p>Clean and repair connector(s) as required (WP 0113 00).</p>

Table 1. Error Code 1311 - Injector Circuit Failure Troubleshooting Procedures - Continued.

MALFUNCTION	TEST OR INSPECTION	CORRECTIVE ACTION
<p>Error Code 1311 - Injector Circuit Failure - Continued.</p>	<p>b. Check actuator harness, actuator harness connector, and 15-pin connector for dirt or moisture in or on connector and for missing or damaged connector seals.</p> <p>2. Place ignition switch in OFF position and disconnect actuator harness and sensor harness from engine ECU and actuator harness from 15-pin connector at front of engine below rocker arm cover. Perform the following resistance checks.</p> <p>a. Measure resistance from actuator harness connector pin 9 to all other pins in actuator harness connector. Resistance should be greater than 100k Ohms.</p> <p>b. Measure resistance from actuator harness connector pin 9 to all other pins in sensor harness connector. Resistance should be greater than 100k Ohms.</p>	<p>Remove dirt and moisture from connector. Replace missing or damaged connector seals (WP 0113 00).</p> <p>a. If resistance is not as specified, repair or replace connectors (WP 0113 00).</p> <p>b. If internal actuator harness requires replacement, notify SRA.</p> <p>a. If resistance is not as specified, repair or replace connectors (WP 0113 00).</p> <p>b. If internal actuator harness requires replacement, notify SRA.</p>

>100K OHMS
Test All Pins

Test All Pins

>100K OHMS
350-1230

Table 1. Error Code 1311 - Injector Circuit Failure Troubleshooting Procedures - Continued.

MALFUNCTION	TEST OR INSPECTION	CORRECTIVE ACTION
<p>Error Code 1311 - Injector Circuit Failure - Continued.</p>	<p>c. Measure resistance from actuator harness connector pin 10 to all other pins in actuator harness connector. Resistance should be greater than 100k Ohms.</p> <p>d. Measure resistance from actuator harness connector pin 10 to all other pins in sensor harness connector. Resistance should be greater than 100k Ohms.</p> <p>3. Place ignition switch in OFF position and disconnect actuator harness from engine ECU. Remove rocker arm cover (WP 0052 00). Disconnect internal actuator harness from 15-pin connector.</p> <p>a. Inspect actuator harness connector, engine ECU connector, and 15-pin connector for dirty, corroded, bent, broken, pushed back, and extended pins.</p> <p>b. Check actuator harness connector, engine ECU connector, and 15-pin connector for dirt or moisture in or on connector and for missing or damaged connector seals.</p> <p>4. Place ignition switch in OFF position and disconnect internal actuator harness from 15-pin connector and from no. 1 injector solenoid.</p>	<p>a. If resistance is not as specified, repair or replace connectors (WP 0113 00).</p> <p>b. If internal actuator harness requires replacement, notify SRA.</p> <p>a. If resistance is not as specified, repair or replace connectors (WP 0113 00).</p> <p>b. If internal actuator harness requires replacement, notify SRA.</p> <p>Clean and repair connector(s) as required (WP 0113 00).</p> <p>Remove dirt and moisture from connector. Replace missing or damaged connector seals (WP 0113 00).</p>

Table 1. Error Code 1311 - Injector Circuit Failure Troubleshooting Procedures - Continued.

MALFUNCTION	TEST OR INSPECTION	CORRECTIVE ACTION
<p>Error Code 1311 - Injector Circuit Failure - Continued.</p>	<p>a. Measure resistance from 15-pin connector pin 1 to all other pins in connector. Resistance should be greater than 100k Ohms.</p> <p>b. Measure resistance from 15-pin connector pin 2 to all other pins in connector. Resistance should be greater than 100k Ohms.</p> <p>5. Place ignition switch in OFF position and, with rocker arm cover removed, disconnect internal actuator harness from injector solenoid.</p> <p>6. Measure resistance from injector solenoid pin A to pin B. Resistance should be 0.5 to 1.5 Ohms.</p> <p>7. Place ignition switch in OFF position and, with rocker arm cover removed, disconnect internal actuator harness from injector solenoid and remove injector solenoid wires from solenoid.</p> <p>8. Measure resistance from post to post on solenoid. Resistance should be 0.5 to 1.5 Ohms.</p>	<p>a. If resistance is not as specified, repair or replace connectors (WP 0113 00).</p> <p>b. If internal actuator harness requires replacement, notify SRA.</p> <p>a. If resistance is not as specified, repair or replace connectors (WP 0113 00).</p> <p>b. If internal actuator harness requires replacement, notify SRA.</p> <p>a. If resistance is as specified, replace engine ECU (WP 0079 00).</p> <p>b. If resistance is not as specified, replace injector (WP 0215 00).</p> <p>If resistance is not as specified, replace injector (WP 0215 00).</p>



WARNING

Injector solenoids receive high voltage when engine is operating. To avoid personal injury or death from electrical shock, do not wear jewelry or damp clothing, and do not touch injector solenoids or solenoid wires when engine is operating.

Table 2. Error Code 1311 - Injector Circuit Failure Troubleshooting Procedures.


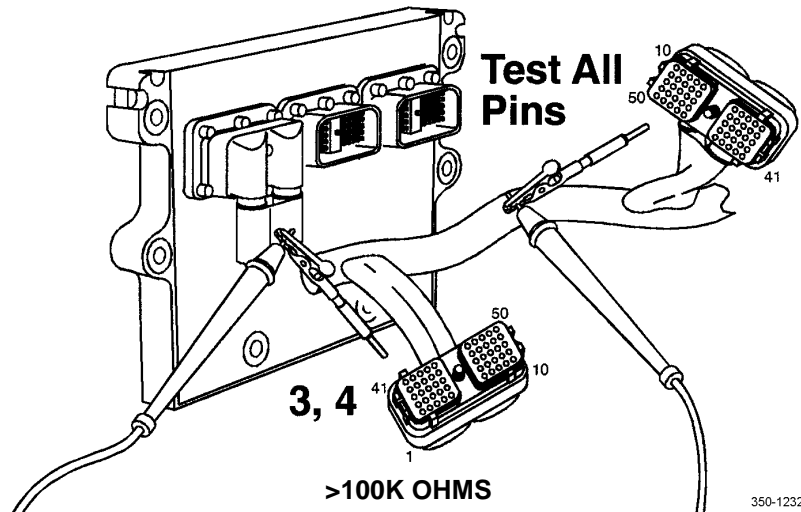
MALFUNCTION	TEST OR INSPECTION	CORRECTIVE ACTION
<p>Error Code 1312 - Injector Circuit Failure.</p> 	<ol style="list-style-type: none"> 1. Place ignition switch in OFF position and disconnect actuator harness from engine ECU and from 15-pin connector at front of engine below rocker arm cover. <ol style="list-style-type: none"> a. Inspect actuator harness, actuator harness connector, and 15-pin connector for dirty, corroded, bent, broken, pushed back, and extended pins. b. Check actuator harness, actuator harness connector, and 15-pin connector for dirt or moisture in or on connector and for missing or damaged connector seals. 2. Place ignition switch in OFF position and disconnect actuator harness and sensor harness from engine ECU and actuator harness from 15-pin connector at front of engine below rocker arm cover. Perform the following resistance checks. <ol style="list-style-type: none"> a. Measure resistance from actuator harness connector pin 3 to all other pins in actuator harness connector. Resistance should be greater than 100k Ohms. 	<p>Clean and repair connector(s) as required (WP 0113 00).</p> <p>Remove dirt and moisture from connector. Replace missing or damaged connector seals (WP 0113 00).</p> <ol style="list-style-type: none"> a. If resistance is not as specified, repair or replace connectors (WP 0113 00). b. If internal actuator harness requires replacement, notify SRA.

Table 2. Error Code 1311 - Injector Circuit Failure Troubleshooting Procedures - Continued.

MALFUNCTION	TEST OR INSPECTION	CORRECTIVE ACTION
<p>Error Code 1312 - Injector Circuit Failure - Continued.</p>	<p>b. Measure resistance from actuator harness connector pin 3 to all other pins in sensor harness connector. Resistance should be greater than 100k Ohms.</p> <p>c. Measure resistance from actuator harness connector pin 4 to all other pins in actuator harness connector. Resistance should be greater than 100k Ohms.</p> <p>d. Measure resistance from actuator harness connector pin 4 to all other pins in sensor harness connector. Resistance should be greater than 100k Ohms.</p>	<p>a. If resistance is not as specified, repair or replace connectors (WP 0113 00).</p> <p>b. If internal actuator harness requires replacement, notify SRA.</p> <p>a. If resistance is not as specified, repair or replace connectors (WP 0113 00).</p> <p>b. If internal actuator harness requires replacement, notify SRA.</p> <p>a. If resistance is not as specified, repair or replace connectors (WP 0113 00).</p> <p>b. If internal actuator harness requires replacement, notify SRA.</p>



3. Place ignition switch in OFF position and disconnect actuator harness from engine ECU. Remove rocker arm cover (WP 0052 00). Disconnect internal actuator harness from 15-pin connector.

Table 2. Error Code 1311 - Injector Circuit Failure Troubleshooting Procedures - Continued.

MALFUNCTION	TEST OR INSPECTION	CORRECTIVE ACTION
<p>Error Code 1312 - Injector Circuit Failure - Continued.</p>	<p>a. Inspect actuator harness connector, engine ECU connector, and 15-pin connector for dirty, corroded, bent, broken, pushed back, and extended pins.</p> <p>b. Check actuator harness connector, engine ECU connector, and 15-pin connector for dirt or moisture in or on connector and for missing or damaged connector seals.</p> <p>4. Place ignition switch in OFF position and disconnect internal actuator harness from 15-pin connector and from no. 5 injector solenoid.</p> <p>a. Measure resistance from 15-pin connector pin 9 to all other pins in connector. Resistance should be greater than 100k Ohms.</p> <p>b. Measure resistance from 15-pin connector pin 10 to all other pins in connector. Resistance should be greater than 100k Ohms.</p> <p>5. Place ignition switch in OFF position and, with rocker arm cover removed, disconnect internal actuator harness from injector solenoid.</p>	<p>Clean and repair connector(s) as required (WP 0113 00).</p> <p>Remove dirt and moisture from connector. Replace missing or damaged connector seals (WP 0113 00).</p> <p>a. If resistance is not as specified, repair or replace connectors (WP 0113 00).</p> <p>b. If internal actuator harness requires replacement, notify SRA.</p> <p>a. If resistance is not as specified, repair or replace connectors (WP 0113 00).</p> <p>b. If internal actuator harness requires replacement, notify SRA.</p>

Table 2. Error Code 1311 - Injector Circuit Failure Troubleshooting Procedures - Continued.

MALFUNCTION	TEST OR INSPECTION	CORRECTIVE ACTION
<p>Error Code 1312 - Injector Circuit Failure - Continued.</p>	<p>6. Measure resistance from injector solenoid pin A to pin B. Resistance should be 0.5 to 1.5 Ohms.</p> <p>7. Place ignition switch in OFF position and, with rocker arm cover removed, disconnect internal actuator harness from injector solenoid and remove injector solenoid wires from solenoid.</p> <p>8. Measure resistance from post to post on solenoid. Resistance should be 0.5 to 1.5 Ohms.</p>	<p>a. If resistance is as specified, replace engine ECU (WP 0079 00).</p> <p>b. If resistance is not as specified, replace injector (WP 0215 00).</p> <p>If resistance is not as specified, replace injector (WP 0215 00).</p>



WARNING

Injector solenoids receive high voltage when engine is operating. To avoid personal injury or death from electrical shock, do not wear jewelry or damp clothing, and do not touch injector solenoids or solenoid wires when engine is operating.

Table 3. Error Code 1313 - Injector Circuit Failure Troubleshooting Procedures.


MALFUNCTION	TEST OR INSPECTION	CORRECTIVE ACTION
<p>Error Code 1313 - Injector Circuit Failure.</p> 	<p>1. Place ignition switch in OFF position and disconnect actuator harness from engine ECU and from 15-pin connector at front of engine below rocker arm cover.</p> <p>a. Inspect actuator harness, actuator harness connector, and 15-pin connector for dirty, corroded, bent, broken, pushed back, and extended pins.</p>	<p>Clean and repair connector(s) as required (WP 0113 00).</p>

Table 3. Error Code 1313 - Injector Circuit Failure Troubleshooting Procedures - Continued.

MALFUNCTION	TEST OR INSPECTION	CORRECTIVE ACTION
<p>Error Code 1313 - Injector Circuit Failure - Continued.</p>	<p>b. Check actuator harness, actuator harness connector, and 15-pin connector for dirt or moisture in or on connector and for missing or damaged connector seals.</p> <p>2. Place ignition switch in OFF position and disconnect actuator harness and sensor harness from engine ECU and actuator harness from 15-pin connector at front of engine below rocker arm cover. Perform the following resistance checks.</p> <p>a. Measure resistance from actuator harness connector pin 6 to all other pins in actuator harness connector. Resistance should be greater than 100k Ohms.</p>	<p>Remove dirt and moisture from connector. Replace missing or damaged connector seals (WP 0113 00).</p> <p>a. If resistance is not as specified, repair or replace connectors (WP 0113 00).</p> <p>b. If internal actuator harness requires replacement, notify SRA.</p>

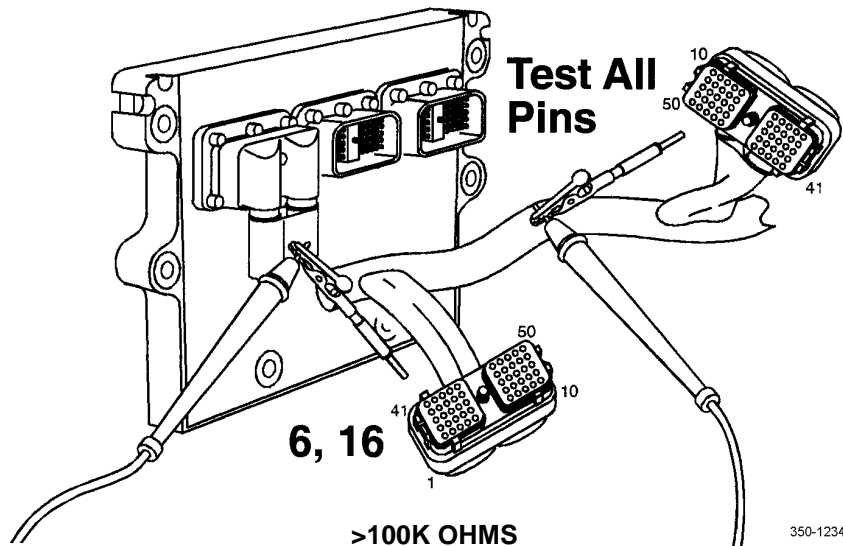


Table 3. Error Code 1313 - Injector Circuit Failure Troubleshooting Procedures - Continued.

MALFUNCTION	TEST OR INSPECTION	CORRECTIVE ACTION
<p>Error Code 1313 - Injector Circuit Failure - Continued.</p>	<p>b. Measure resistance from actuator harness connector pin 6 to all other pins in sensor harness connector. Resistance should be greater than 100k Ohms.</p> <p>c. Measure resistance from actuator harness connector pin 16 to all other pins in actuator harness connector. Resistance should be greater than 100k Ohms.</p> <p>d. Measure resistance from actuator harness connector pin 16 to all other pins in sensor harness connector. Resistance should be greater than 100k Ohms.</p> <p>3. Place ignition switch in OFF position and disconnect actuator harness from engine ECU. Remove rocker arm cover (WP 0052 00). Disconnect internal actuator harness from 15-pin connector.</p> <p>a. Inspect actuator harness connector, engine ECU connector, and 15-pin connector for dirty, corroded, bent, broken, pushed back, and extended pins.</p> <p>b. Check actuator harness connector, engine ECU connector, and 15-pin connector for dirt or moisture in or on connector and for missing or damaged connector seals.</p>	<p>a. If resistance is not as specified, repair or replace connectors (WP 0113 00).</p> <p>b. If internal actuator harness requires replacement, notify SRA.</p> <p>a. If resistance is not as specified, repair or replace connectors (WP 0113 00).</p> <p>b. If internal actuator harness requires replacement, notify SRA.</p> <p>a. If resistance is not as specified, repair or replace connectors (WP 0113 00).</p> <p>b. If internal actuator harness requires replacement, notify SRA.</p> <p>Clean and repair connector(s) as required (WP 0113 00).</p> <p>Remove dirt and moisture from connector. Replace missing or damaged connector seals (WP 0113 00).</p>

Table 3. Error Code 1313 - Injector Circuit Failure Troubleshooting Procedures - Continued.

MALFUNCTION	TEST OR INSPECTION	CORRECTIVE ACTION
<p>Error Code 1313 - Injector Circuit Failure - Continued.</p>	<p>4. Place ignition switch in OFF position and disconnect internal actuator harness from 15-pin connector and from no. 3 injector solenoid.</p> <p>a. Measure resistance from 15-pin connector pin 5 to all other pins in connector. Resistance should be greater than 100k Ohms.</p> <p>b. Measure resistance from 15-pin connector pin 6 to all other pins in connector. Resistance should be greater than 100k Ohms.</p> <p>5. Place ignition switch in OFF position and, with rocker arm cover removed, disconnect internal actuator harness from injector solenoid.</p> <p>6. Measure resistance from injector solenoid pin A to pin B. Resistance should be 0.5 to 1.5 Ohms.</p> <p>7. Place ignition switch in OFF position and, with rocker arm cover removed, disconnect internal actuator harness from injector solenoid and remove injector solenoid wires from solenoid.</p> <p>8. Measure resistance from post to post on solenoid. Resistance should be 0.5 to 1.5 Ohms.</p>	<p>a. If resistance is not as specified, repair or replace connectors (WP 0113 00).</p> <p>b. If internal actuator harness requires replacement, notify SRA.</p> <p>a. If resistance is not as specified, repair or replace connectors (WP 0113 00).</p> <p>b. If internal actuator harness requires replacement, notify SRA.</p> <p>a. If resistance is as specified, replace engine ECU (WP 0079 00).</p> <p>b. If resistance is not as specified, replace injector (WP 0215 00).</p> <p>If resistance is not as specified, replace injector (WP 0215 00).</p>



WARNING

Injector solenoids receive high voltage when engine is operating. To avoid personal injury or death from electrical shock, do not wear jewelry or damp clothing, and do not touch injector solenoids or solenoid wires when engine is operating.

Table 4. Error Code 1314 - Injector Circuit Failure Troubleshooting Procedures.


MALFUNCTION	TEST OR INSPECTION	CORRECTIVE ACTION
<p>Error Code 1314 - Injector Circuit Failure.</p> 	<ol style="list-style-type: none"> 1. Place ignition switch in OFF position and disconnect actuator harness from engine ECU and from 15-pin connector at front of engine below rocker arm cover. <ol style="list-style-type: none"> a. Inspect actuator harness, actuator harness connector, and 15-pin connector for dirty, corroded, bent, broken, pushed back, and extended pins. b. Check actuator harness, actuator harness connector, and 15-pin connector for dirt or moisture in or on connector and for missing or damaged connector seals. 2. Place ignition switch in OFF position and disconnect actuator harness and sensor harness from engine ECU and actuator harness from 15-pin connector at front of engine below rocker arm cover. Perform the following resistance checks. <ol style="list-style-type: none"> a. Measure resistance from actuator harness connector pin 2 to all other pins in actuator harness connector. Resistance should be greater than 100k Ohms. 	<p>Clean and repair connector(s) as required (WP 0113 00).</p> <p>Remove dirt and moisture from connector. Replace missing or damaged connector seals (WP 0113 00).</p> <ol style="list-style-type: none"> a. If resistance is not as specified, repair or replace connectors (WP 0113 00). b. If internal actuator harness requires replacement, notify SRA.

Table 4. Error Code 1314 - Injector Circuit Failure Troubleshooting Procedures - Continued.

MALFUNCTION	TEST OR INSPECTION	CORRECTIVE ACTION
<p>Error Code 1314 - Injector Circuit Failure - Continued.</p>	<p>b. Measure resistance from actuator harness connector pin 2 to all other pins in sensor harness connector. Resistance should be greater than 100k Ohms.</p> <p>c. Measure resistance from actuator harness connector pin 1 to all other pins in actuator harness connector. Resistance should be greater than 100k Ohms.</p> <p>d. Measure resistance from actuator harness connector pin 1 to all other pins in sensor harness connector. Resistance should be greater than 100k Ohms.</p>	<p>a. If resistance is not as specified, repair or replace connectors (WP 0113 00).</p> <p>b. If internal actuator harness requires replacement, notify SRA.</p> <p>a. If resistance is not as specified, repair or replace connectors (WP 0113 00).</p> <p>b. If internal actuator harness requires replacement, notify SRA.</p> <p>a. If resistance is not as specified, repair or replace connectors (WP 0113 00).</p> <p>b. If internal actuator harness requires replacement, notify SRA.</p>

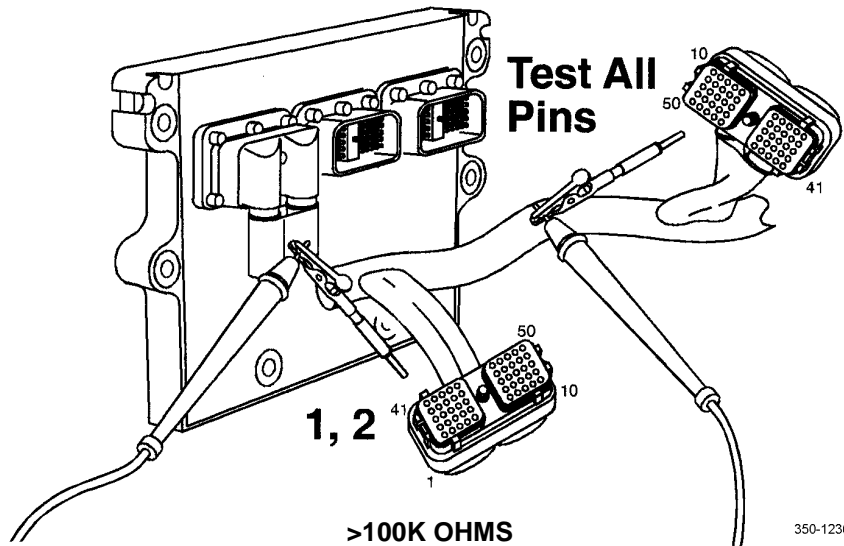


Table 4. Error Code 1314 - Injector Circuit Failure Troubleshooting Procedures - Continued.

MALFUNCTION	TEST OR INSPECTION	CORRECTIVE ACTION
<p>Error Code 1314 - Injector Circuit Failure - Continued.</p>	<p>3. Place ignition switch in OFF position and disconnect actuator harness from engine ECU. Remove rocker arm cover (WP 0052 00). Disconnect internal actuator harness from 15-pin connector.</p> <p>a. Inspect actuator harness connector, engine ECU connector, and 15-pin connector for dirty, corroded, bent, broken, pushed back, and extended pins.</p> <p>b. Check actuator harness connector, engine ECU connector, and 15-pin connector for dirt or moisture in or on connector and for missing or damaged connector seals.</p> <p>4. Place ignition switch in OFF position and disconnect internal actuator harness from 15-pin connector and from no. 6 injector solenoid.</p> <p>a. Measure resistance from 15-pin connector pin 11 to all other pins in connector. Resistance should be greater than 100k Ohms.</p> <p>b. Measure resistance from 15-pin connector pin 12 to all other pins in connector. Resistance should be greater than 100k Ohms.</p> <p>5. Place ignition switch in OFF position and, with rocker arm cover removed, disconnect internal actuator harness from injector solenoid.</p>	<p>Clean and repair connector(s) as required (WP 0113 00).</p> <p>Remove dirt and moisture from connector. Replace missing or damaged connector seals (WP 0113 00).</p> <p>a. If resistance is not as specified, repair or replace connectors (WP 0113 00).</p> <p>b. If internal actuator harness requires replacement, notify SRA.</p> <p>a. If resistance is not as specified, repair or replace connectors (WP 0113 00).</p> <p>b. If internal actuator harness requires replacement, notify SRA.</p>

Table 4. Error Code 1314 - Injector Circuit Failure Troubleshooting Procedures - Continued.

MALFUNCTION	TEST OR INSPECTION	CORRECTIVE ACTION
<p>Error Code 1314 - Injector Circuit Failure - Continued.</p>	<p>6. Measure resistance from injector solenoid pin A to pin B. Resistance should be 0.5 to 1.5 Ohms.</p> <p>7. Place ignition switch in OFF position and, with rocker arm cover removed, disconnect internal actuator harness from injector solenoid and remove injector solenoid wires from solenoid.</p> <p>8. Measure resistance from post to post on solenoid. Resistance should be 0.5 to 1.5 Ohms.</p>	<p>a. If resistance is as specified, replace engine ECU (WP 0079 00).</p> <p>b. If resistance is not as specified, replace injector (WP 0215 00).</p> <p>If resistance is not as specified, replace injector (WP 0215 00).</p>



WARNING

Injector solenoids receive high voltage when engine is operating. To avoid personal injury or death from electrical shock, do not wear jewelry or damp clothing, and do not touch injector solenoids or solenoid wires when engine is operating.

Table 5. Error Code 1315 - Injector Circuit Failure Troubleshooting Procedures.


MALFUNCTION	TEST OR INSPECTION	CORRECTIVE ACTION
<p>Error Code 1315 - Injector Circuit Failure</p> 	<p>1. Place ignition switch in OFF position and disconnect actuator harness from engine ECU and from 15-pin connector at front of engine below rocker arm cover.</p> <p>a. Inspect actuator harness, actuator harness connector, and 15-pin connector for dirty, corroded, bent, broken, pushed back, and extended pins.</p>	<p>Clean and repair connector(s) as required (WP 0113 00).</p>

Table 5. Error Code 1315 - Injector Circuit Failure Troubleshooting Procedures - Continued.

MALFUNCTION	TEST OR INSPECTION	CORRECTIVE ACTION
<p>Error Code 1315 - Injector Circuit Failure - Continued.</p>	<p>b. Check actuator harness, actuator harness connector, and 15-pin connector for dirt or moisture in or on connector and for missing or damaged connector seals.</p> <p>2. Place ignition switch in OFF position and disconnect actuator harness and sensor harness from engine ECU and actuator harness from 15-pin connector at front of engine below rocker arm cover. Perform the following resistance checks.</p> <p>a. Measure resistance from actuator harness connector pin 7 to all other pins in actuator harness connector. Resistance should be greater than 100k Ohms.</p>	<p>Remove dirt and moisture from connector. Replace missing or damaged connector seals (WP 0113 00).</p> <p>a. If resistance is not as specified, repair or replace connectors (WP 0113 00). b. If internal actuator harness requires replacement, notify SRA.</p>

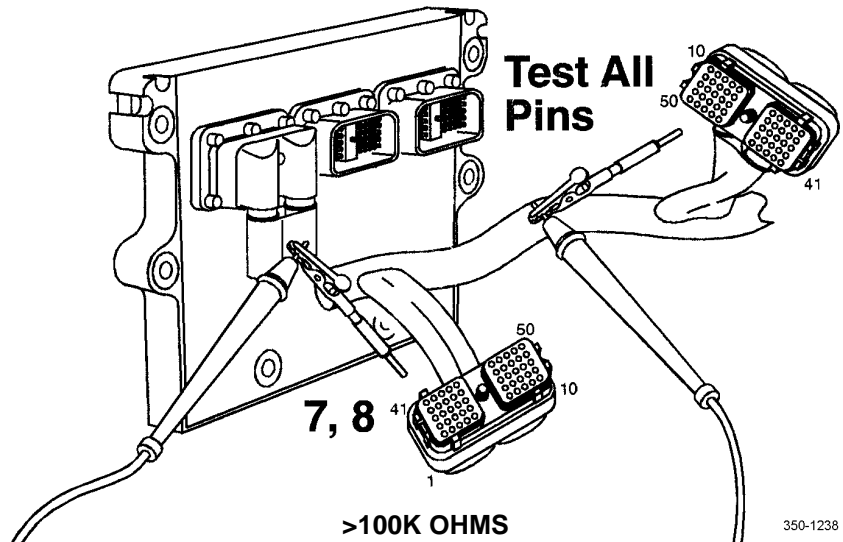


Table 5. Error Code 1315 - Injector Circuit Failure Troubleshooting Procedures - Continued.

MALFUNCTION	TEST OR INSPECTION	CORRECTIVE ACTION
<p>Error Code 1315 - Injector Circuit Failure - Continued.</p>	<p>b. Measure resistance from actuator harness connector pin 7 to all other pins in sensor harness connector. Resistance should be greater than 100k Ohms.</p> <p>c. Measure resistance from actuator harness connector pin 8 to all other pins in actuator harness connector. Resistance should be greater than 100k Ohms.</p> <p>d. Measure resistance from actuator harness connector pin 8 to all other pins in sensor harness connector. Resistance should be greater than 100k Ohms.</p> <p>3. Place ignition switch in OFF position and disconnect actuator harness from engine ECU. Remove rocker arm cover (WP 0052 00). Disconnect internal actuator harness from 15-pin connector.</p> <p>a. Inspect actuator harness connector, engine ECU connector, and 15-pin connector for dirty, corroded, bent, broken, pushed back, and extended pins.</p> <p>b. Check actuator harness connector, engine ECU connector, and 15-pin connector for dirt or moisture in or on connector and for missing or damaged connector seals.</p>	<p>a. If resistance is not as specified, repair or replace connectors (WP 0113 00).</p> <p>b. If internal actuator harness requires replacement, notify SRA.</p> <p>a. If resistance is not as specified, repair or replace connectors (WP 0113 00).</p> <p>b. If internal actuator harness requires replacement, notify SRA.</p> <p>a. If resistance is not as specified, repair or replace connectors (WP 0113 00).</p> <p>b. If internal actuator harness requires replacement, notify SRA.</p> <p>Clean and repair connector(s) as required (WP 0113 00).</p> <p>Remove dirt and moisture from connector. Replace missing or damaged connector seals (WP 0113 00).</p>

Table 5. Error Code 1315 - Injector Circuit Failure Troubleshooting Procedures - Continued.

MALFUNCTION	TEST OR INSPECTION	CORRECTIVE ACTION
<p>Error Code 1315 - Injector Circuit Failure - Continued.</p>	<p>4. Place ignition switch in OFF position and disconnect internal actuator harness from 15-pin connector and from no. 2 injector solenoid.</p> <p>a. Measure resistance from 15-pin connector pin 3 to all other pins in connector. Resistance should be greater than 100k Ohms.</p> <p>b. Measure resistance from 15-pin connector pin 4 to all other pins in connector. Resistance should be greater than 100k Ohms.</p> <p>5. Place ignition switch in OFF position and, with rocker arm cover removed, disconnect internal actuator harness from injector solenoid.</p> <p>6. Measure resistance from injector solenoid pin A to pin B. Resistance should be 0.5 to 1.5 Ohms.</p> <p>7. Place ignition switch in OFF position and, with rocker arm cover removed, disconnect internal actuator harness from injector solenoid and remove injector solenoid wires from solenoid.</p> <p>8. Measure resistance from post to post on solenoid. Resistance should be 0.5 to 1.5 Ohms.</p>	<p>a. If resistance is not as specified, repair or replace connectors (WP 0113 00).</p> <p>b. If internal actuator harness requires replacement, notify SRA.</p> <p>a. If resistance is not as specified, repair or replace connectors (WP 0113 00).</p> <p>b. If internal actuator harness requires replacement, notify SRA.</p> <p>a. If resistance is as specified, replace engine ECU (WP 0079 00 00).</p> <p>b. If resistance is not as specified, replace injector (WP 0215 00).</p> <p>If resistance is not as specified, replace injector (WP 0215 00).</p>



WARNING

Injector solenoids receive high voltage when engine is operating. To avoid personal injury or death from electrical shock, do not wear jewelry or damp clothing, and do not touch injector solenoids or solenoid wires when engine is operating.

Table 6. Error Code 1321 - Injector Circuit Failure Troubleshooting Procedures.


MALFUNCTION	TEST OR INSPECTION	CORRECTIVE ACTION
<p>Error Code 1321 - Injector Circuit Failure.</p> 	<ol style="list-style-type: none"> 1. Place ignition switch in OFF position and disconnect actuator harness from engine ECU and from 15-pin connector at front of engine below rocker arm cover. <ol style="list-style-type: none"> a. Inspect actuator harness, actuator harness connector, and 15-pin connector for dirty, corroded, bent, broken, pushed back, and extended pins. b. Check actuator harness, actuator harness connector, and 15-pin connector for dirt or moisture in or on connector and for missing or damaged connector seals. 2. Place ignition switch in OFF position and disconnect actuator harness and sensor harness from engine ECU and actuator harness from 15-pin connector at front of engine below rocker arm cover. Perform the following resistance checks. <ol style="list-style-type: none"> a. Measure resistance from actuator harness connector pin 26 to all other pins in actuator harness connector. Resistance should be greater than 100k Ohms. 	<p>Clean and repair connector(s) as required (WP 0113 00).</p> <p>Remove dirt and moisture from connector. Replace missing or damaged connector seals (WP 0113 00).</p> <ol style="list-style-type: none"> a. If resistance is not as specified, repair or replace connectors (WP 0113 00). b. If internal actuator harness requires replacement, notify SRA.

Table 6. Error Code 1321 - Injector Circuit Failure Troubleshooting Procedures - Continued.

MALFUNCTION	TEST OR INSPECTION	CORRECTIVE ACTION
<p>Error Code 1321 - Injector Circuit Failure - Continued.</p>	<p>b. Measure resistance from actuator harness connector pin 26 to all other pins in sensor harness connector. Resistance should be greater than 100k Ohms.</p> <p>c. Measure resistance from actuator harness connector pin 36 to all other pins in actuator harness connector. Resistance should be greater than 100k Ohms.</p> <p>d. Measure resistance from actuator harness connector pin 36 to all other pins in sensor harness connector. Resistance should be greater than 100k Ohms.</p>	<p>a. If resistance is not as specified, repair or replace connectors (WP 0113 00).</p> <p>b. If internal actuator harness requires replacement, notify SRA.</p> <p>a. If resistance is not as specified, repair or replace connectors (WP 0113 00).</p> <p>b. If internal actuator harness requires replacement, notify SRA.</p> <p>a. If resistance is not as specified, repair or replace connectors (WP 0113 00).</p> <p>b. If internal actuator harness requires replacement, notify SRA.</p>

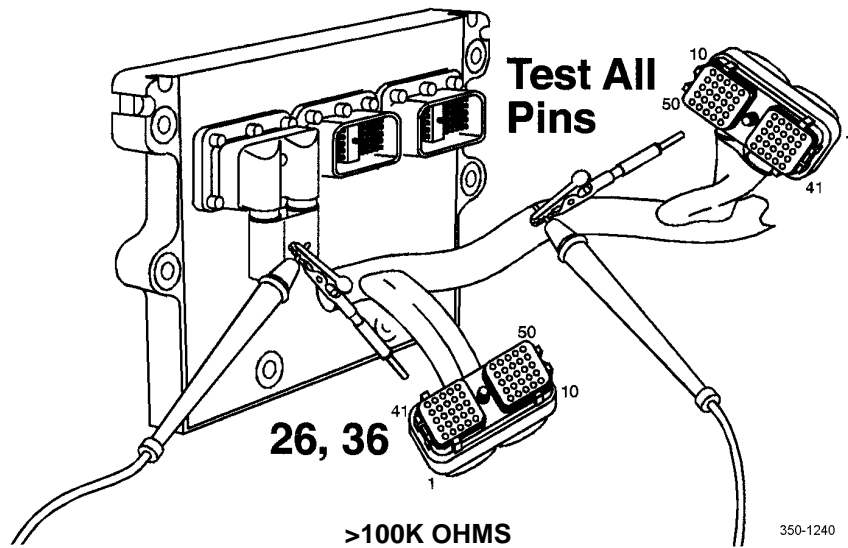


Table 6. Error Code 1321 - Injector Circuit Failure Troubleshooting Procedures - Continued.

MALFUNCTION	TEST OR INSPECTION	CORRECTIVE ACTION
<p>Error Code 1321 - Injector Circuit Failure - Continued.</p>	<p>3. Place ignition switch in OFF position and disconnect actuator harness from engine ECU. Remove rocker arm cover (WP 0052 00). Disconnect internal actuator harness from 15-pin connector.</p> <p>a. Inspect actuator harness connector, engine ECU connector, and 15-pin connector for dirty, corroded, bent, broken, pushed back, and extended pins.</p> <p>b. Check actuator harness connector, engine ECU connector, and 15-pin connector for dirt or moisture in or on connector and for missing or damaged connector seals.</p> <p>4. Place ignition switch in OFF position and disconnect internal actuator harness from 15-pin connector and from no. 4 injector solenoid.</p> <p>a. Measure resistance from 15-pin connector pin 7 to all other pins in connector. Resistance should be greater than 100k Ohms.</p> <p>b. Measure resistance from 15-pin connector pin 8 to all other pins in connector. Resistance should be greater than 100k Ohms.</p> <p>5. Place ignition switch in OFF position and, with rocker arm cover removed, disconnect internal actuator harness from injector solenoid.</p>	<p>Clean and repair connector(s) as required (WP 0113 00).</p> <p>Remove dirt and moisture from connector. Replace missing or damaged connector seals (WP 0113 00).</p> <p>a. If resistance is not as specified, repair or replace connectors (WP 0113 00).</p> <p>b. If internal actuator harness requires replacement, notify SRA.</p> <p>a. If resistance is not as specified, repair or replace connectors (WP 0113 00).</p> <p>b. If internal actuator harness requires replacement, notify SRA.</p>

Table 6. Error Code 1321 - Injector Circuit Failure Troubleshooting Procedures - Continued.

MALFUNCTION	TEST OR INSPECTION	CORRECTIVE ACTION
<p>Error Code 1321 - Injector Circuit Failure - Continued.</p>	<p>6. Measure resistance from injector solenoid pin A to pin B. Resistance should be 0.5 to 1.5 Ohms.</p> <p>7. Place ignition switch in OFF position and, with rocker arm cover removed, disconnect internal actuator harness from injector solenoid and remove injector solenoid wires from solenoid.</p> <p>8. Measure resistance from post to post on solenoid. Resistance should be 0.5 to 1.5 Ohms.</p>	<p>a. If resistance is as specified, replace engine ECU (WP 0079 00).</p> <p>b. If resistance is not as specified, replace injector (WP 0215 00).</p> <p>If resistance is not as specified, replace injector (WP 0215 00).</p>



WARNING

Injector solenoids receive high voltage when engine is operating. To avoid personal injury or death from electrical shock, do not wear jewelry or damp clothing, and do not touch injector solenoids or solenoid wires when engine is operating.

Table 7. Error Code 1322 - Injector Circuit Failure Troubleshooting Procedures.


MALFUNCTION	TEST OR INSPECTION	CORRECTIVE ACTION
<p>Error Code 1322 - Injector Circuit Failure.</p> 	<p>1. Place ignition switch in OFF position and disconnect actuator harness from engine ECU.</p> <p>a. Inspect actuator harness and ECU connector for dirty, corroded, bent, broken, pushed back, and extended pins.</p>	<p>Clean and repair connector(s) as required (WP 0113 00).</p>

Table 7. Error Code 1322 - Injector Circuit Failure Troubleshooting Procedures - Continued.

MALFUNCTION	TEST OR INSPECTION	CORRECTIVE ACTION
<p>Error Code 1322 - Injector Circuit Failure - Continued.</p>	<p>b. Check actuator harness and ECU connector for dirt or moisture in or on connector and for missing or damaged connector seals.</p> <p>2. Place ignition switch in OFF position and disconnect actuator harness from engine ECU and 15-pin connector at front of engine below rocker arm cover. Install jumper wire from pin 1 to pin 2 at 15-pin connector, actuator harness side.</p> <p>3. Measure resistance from actuator harness connector pin 9 to actuator harness connector pin 10. Resistance should be less than 10 Ohms.</p>	<p>Remove dirt and moisture from connector. Replace missing or damaged connector seals (WP 0113 00).</p> <p>a. If resistance is not as specified, repair or replace connectors (WP 0113 00).</p> <p>b. If engine harness requires replacement, notify SRA.</p>

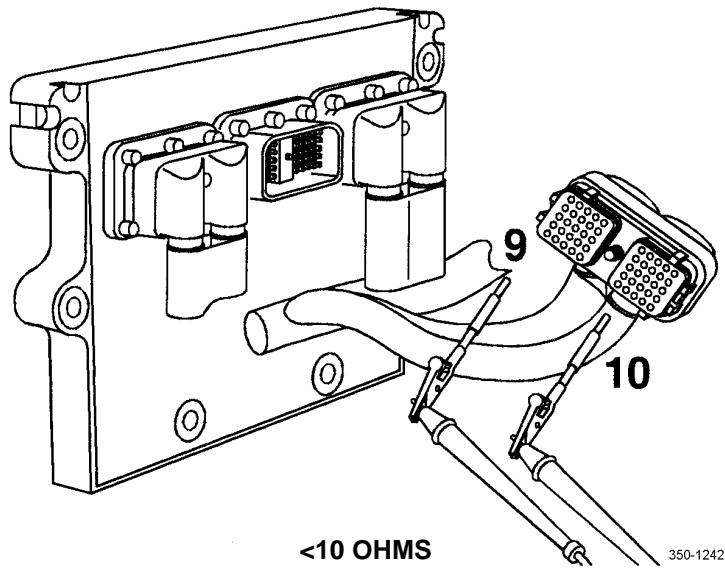


Table 7. Error Code 1322 - Injector Circuit Failure Troubleshooting Procedures - Continued.

MALFUNCTION	TEST OR INSPECTION	CORRECTIVE ACTION
<p>Error Code 1322 - Injector Circuit Failure - Continued.</p>	<p>4. Place ignition switch in OFF position and disconnect actuator harness from engine ECU and 15-pin connector at front of engine below rocker arm cover. Disconnect sensor harness from ECU engine.</p> <p>a. Measure resistance from actuator harness connector pin 9 to all pins in actuator harness connector. Resistance should be greater than 100k Ohms.</p> <p>b. Measure resistance from actuator harness connector pin 9 to all pins in sensor harness connector. Resistance should be greater than 100k Ohms.</p> <p>c. Measure resistance from actuator harness connector pin 10 to all pins in actuator harness connector. Resistance should be greater than 100k Ohms.</p>	<p>a. If resistance is not as specified, repair or replace connectors (WP 0113 00).</p> <p>b. If engine harness requires replacement, notify SRA.</p> <p>a. If resistance is not as specified, repair or replace connectors (WP 0113 00).</p> <p>b. If engine harness requires replacement, notify SRA.</p> <p>a. If resistance is not as specified, repair or replace connectors (WP 0113 00).</p> <p>b. If engine harness requires replacement, notify SRA.</p>

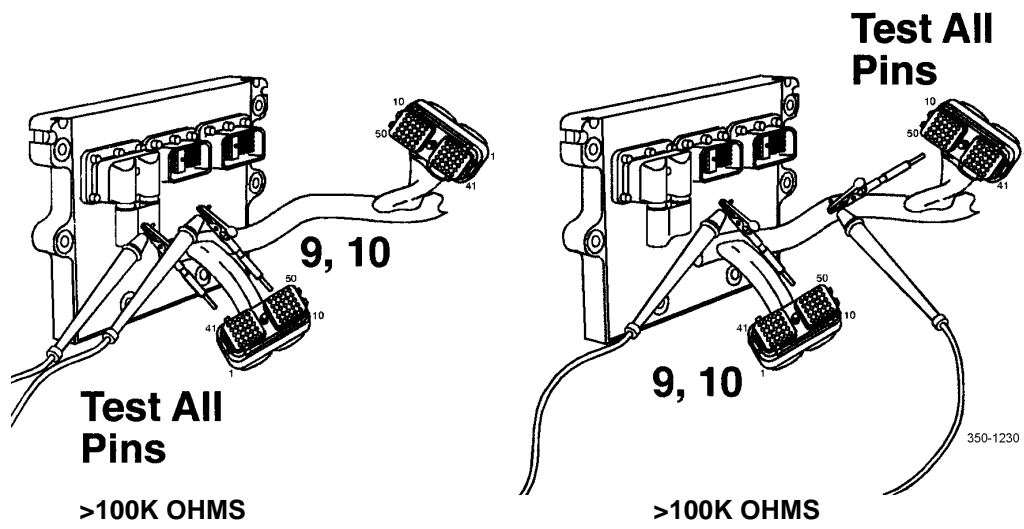


Table 7. Error Code 1322 - Injector Circuit Failure Troubleshooting Procedures - Continued.

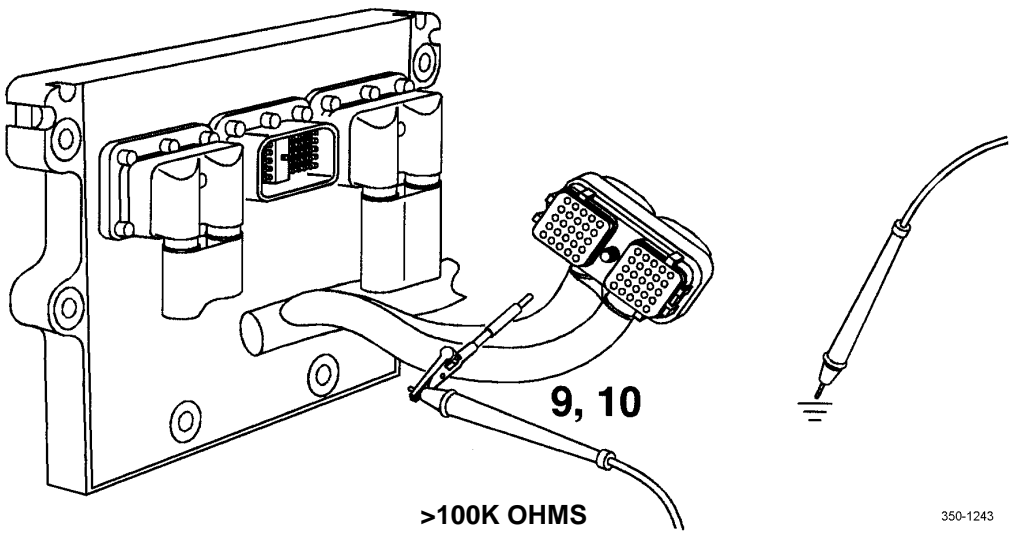
MALFUNCTION	TEST OR INSPECTION	CORRECTIVE ACTION
<p>Error Code 1322 - Injector Circuit Failure - Continued.</p>	<p>d. Measure resistance from actuator harness connector pin 10 to all pins in sensor harness connector. Resistance should be greater than 100k Ohms.</p> <p>5. Place ignition switch in OFF position and disconnect actuator harness 15-pin connector at front of engine below rocker arm cover. Disconnect actuator harness connector from engine ECU.</p> <p>a. Measure resistance from actuator harness connector pin 9 to engine block ground. Resistance should be greater than 100k Ohms.</p> <p>b. Measure resistance from actuator harness connector pin 10 to engine block ground. Resistance should be greater than 100k Ohms.</p>	<p>a. If resistance is not as specified, repair or replace connectors (WP 0113 00).</p> <p>b. If engine harness requires replacement, notify SRA.</p> <p>a. If resistance is not as specified, repair or replace connectors (WP 0113 00).</p> <p>b. If engine harness requires replacement, notify SRA.</p> <p>a. If resistance is not as specified, repair or replace connectors (WP 0113 00).</p> <p>b. If engine harness requires replacement, notify SRA.</p>
 <p style="text-align: center;">>100K OHMS</p> <p style="text-align: right; font-size: small;">350-1243</p>		

Table 7. Error Code 1322 - Injector Circuit Failure Troubleshooting Procedures - Continued.

MALFUNCTION	TEST OR INSPECTION	CORRECTIVE ACTION
<p>Error Code 1322 - Injector Circuit Failure - Continued.</p>	<p>6. Place ignition switch in OFF position. Remove rocker arm cover (WP 0052 00). Disconnect injector solenoid connector from no. 1 injector solenoid and internal actuator harness from 15-pin connector.</p> <p>a. Inspect internal actuator harness and injector solenoid connector for dirty, corroded, bent, broken, pushed back, and extended pins.</p> <p>b. Check internal actuator harness and injector solenoid connector for dirt or moisture in or on connector and for missing or damaged connector seals.</p> <p>7. Place ignition switch in OFF position and, with rocker arm cover removed, disconnect actuator harness from 15-pin connector and injector solenoid wires from no. 1 injector solenoid.</p> <p>a. Measure resistance from 15-pin connector pin 1 (or A) to each injector pigtail nut that connects the no. 1 injector (resistance to one of these nuts must be within specifications). Resistance should be less than 10 Ohms.</p>	<p>Clean and repair connector(s) as required (WP 0113 00).</p> <p>Remove dirt and moisture from connector. Replace missing or damaged connector seals (WP 0113 00).</p> <p>a. If resistance is not as specified, repair or replace connectors (WP 0113 00).</p> <p>b. If internal actuator harness requires replacement, notify SRA.</p>

Table 7. Error Code 1322 - Injector Circuit Failure Troubleshooting Procedures - Continued.

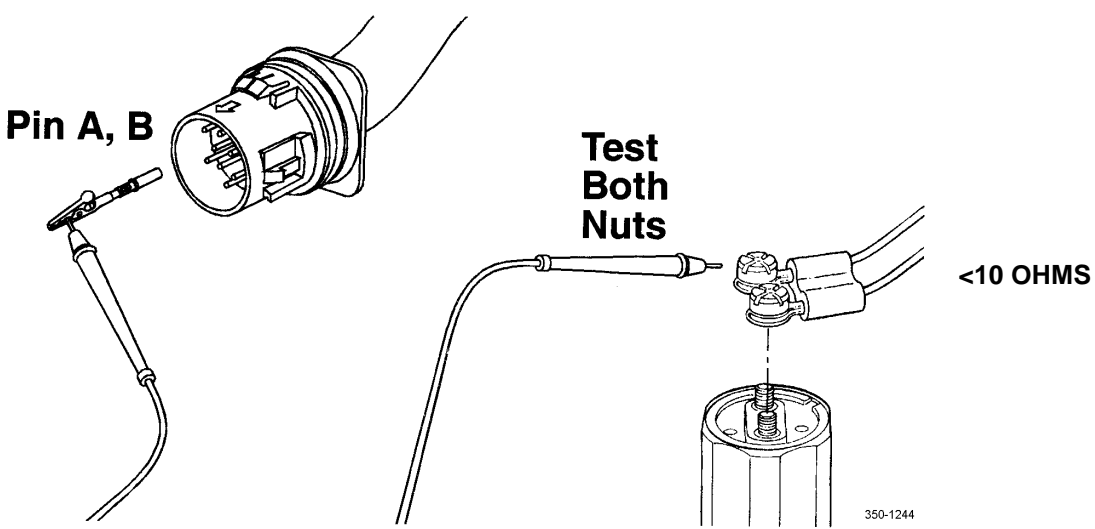
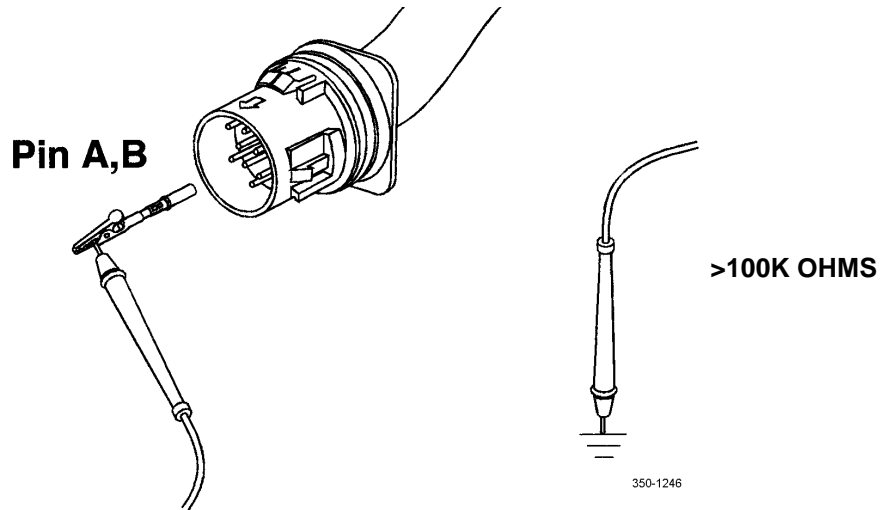
MALFUNCTION	TEST OR INSPECTION	CORRECTIVE ACTION
<p>Error Code 1322 - Injector Circuit Failure - Continued.</p> 	<p>b. Measure resistance from 15-pin connector pin 2 (or B) to each injector pigtail nut that connects the no. 1 injector (resistance to one of these nuts must be within specifications). Resistance should be less than 10 Ohms.</p> <p>8. Place ignition switch in OFF position and disconnect internal actuator harness from injector solenoid connector and disconnect injector solenoid wires from solenoid.</p> <p>a. Measure resistance from pin A (or 1) of injector solenoid connector to injector wire pigtail nut. Resistance should be less than 10 Ohms.</p> <p>b. Measure resistance from pin B (or 2) of injector solenoid connector to injector wire pigtail nut. Resistance should be less than 10 Ohms.</p>	<p>If resistance is not as specified, notify SRA to replace internal actuator harness.</p> <p>a. If resistance is as specified, notify SRA to replace internal actuator harness.</p> <p>b. If resistance is not as specified, replace injector solenoid wires.</p> <p>a. If resistance is as specified, notify SRA to replace internal actuator harness.</p> <p>b. If resistance is not as specified, replace injector solenoid wires.</p>

Table 7. Error Code 1322 - Injector Circuit Failure Troubleshooting Procedures - Continued.

MALFUNCTION	TEST OR INSPECTION	CORRECTIVE ACTION
<p>Error Code 1322 - Injector Circuit Failure - Continued.</p>	<p>9. Place ignition switch in OFF position and, with rocker arm cover removed, disconnect internal actuator harness from 15-pin connector.</p> <p>a. Measure resistance from pin 1 (or A) on internal harness side of actuator harness 15-pin connector to all other pins in connector. Resistance should be greater than 100k Ohms.</p> <p>b. Measure resistance from pin 2 (or B) on internal harness side of actuator harness 15-pin connector to all other pins in connector. Resistance should be greater than 100k Ohms.</p>	<p>If resistance is not as specified, notify SRA to replace internal actuator harness.</p> <p>If resistance is not as specified, notify SRA to replace internal actuator harness.</p>
<p>10. Place ignition switch in OFF position and, with rocker arm cover removed, disconnect injector solenoid connector on internal actuator harness from no. 1 injector solenoid.</p>		

Table 7. Error Code 1322 - Injector Circuit Failure Troubleshooting Procedures - Continued.

MALFUNCTION	TEST OR INSPECTION	CORRECTIVE ACTION
<p>Error Code 1322 - Injector Circuit Failure - Continued.</p>	<p>a. Measure resistance from pin 1 (or A) on solenoid connector to engine block ground. Resistance should be greater than 100k Ohms.</p> <p>b. Measure resistance from pin 2 (or B) on solenoid connector to engine block ground. Resistance should be greater than 100k Ohms.</p> <p>11. Place ignition switch in OFF position and, with rocker arm cover removed, disconnect no. 1 injector solenoid from internal actuator harness.</p> <p>12. Measure resistance from post to post on solenoid. Resistance should be 0.5 to 1.5 Ohms.</p>	<p>If resistance is not as specified, notify SRA to replace internal actuator harness.</p> <p>If resistance is not as specified, notify SRA to replace internal actuator harness.</p> <p>a. If resistance is as specified, replace engine ECU (WP 0079 00).</p> <p>b. If resistance is not as specified, replace injector (WP 0215 00).</p>



350-1246



WARNING

Injector solenoids receive high voltage when engine is operating. To avoid personal injury or death from electrical shock, do not wear jewelry or damp clothing, and do not touch injector solenoids or solenoid wires when engine is operating.

Table 8. Error Code 1323 - Injector Circuit Failure Troubleshooting Procedures.


MALFUNCTION	TEST OR INSPECTION	CORRECTIVE ACTION
<p>Error Code 1323 - Injector Circuit Failure.</p> 	<ol style="list-style-type: none"> 1. Place ignition switch in OFF position and disconnect actuator harness from engine ECU. <ol style="list-style-type: none"> a. Inspect actuator harness and ECU connector for dirty, corroded, bent, broken, pushed back, and extended pins. b. Check actuator harness and ECU connector for dirt or moisture in or on connector and for missing or damaged connector seals. 2. Place ignition switch in OFF position and disconnect actuator harness from engine ECU and 15-pin connector at front of engine below rocker arm cover. Install jumper wire from pin 9 to pin 10 at 15-pin connector, actuator harness side. 3. Measure resistance from actuator harness connector pin 3 to pin 4. Resistance should be less than 10 Ohms. 	<ol style="list-style-type: none"> a. Clean and repair connector(s) as required (WP 0113 00). b. Remove dirt and moisture from connector. Replace missing or damaged connector seals (WP 0113 00). a. If resistance is not as specified, repair or replace connectors (WP 0113 00). b. If engine harness requires replacement, notify SRA.

Table 8. Error Code 1323 - Injector Circuit Failure Troubleshooting Procedures - Continued.

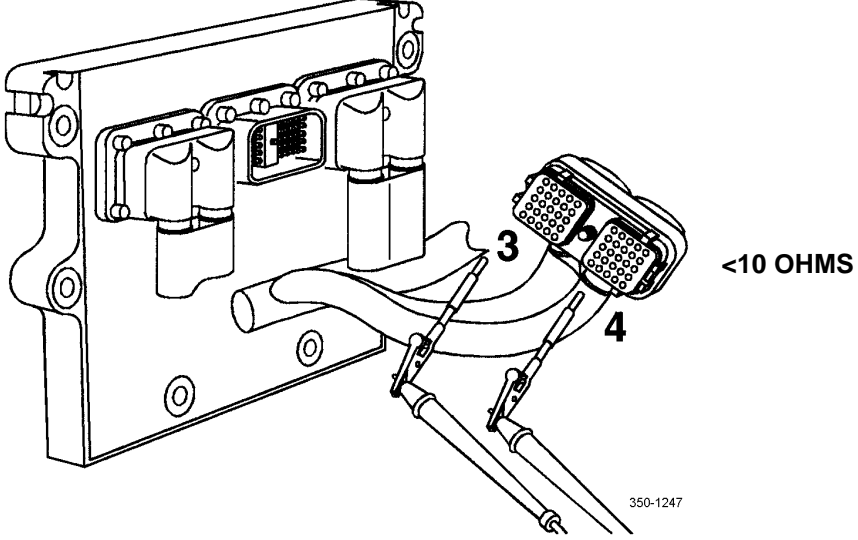
MALFUNCTION	TEST OR INSPECTION	CORRECTIVE ACTION
<p>Error Code 1323 - Injector Circuit Failure - Continued.</p> 	<p>4. Place ignition switch in OFF position and disconnect actuator harness from engine ECU and 15-pin connector at front of engine below rocker arm cover. Disconnect sensor harness from engine ECU.</p> <p>a. Measure resistance from actuator harness connector pin 3 to all pins in actuator harness connector. Resistance should be greater than 100k Ohms.</p> <p>b. Measure resistance from actuator harness connector pin 3 to all pins in sensor harness connector. Resistance should be greater than 100k Ohms.</p>	<p>a. If resistance is not as specified, repair or replace connectors (WP 0113 00).</p> <p>b. If engine harness requires replacement, notify SRA.</p> <p>a. If resistance is not as specified, repair or replace connectors (WP 0113 00).</p> <p>b. If engine harness requires replacement, notify SRA.</p>

Table 8. Error Code 1323 - Injector Circuit Failure Troubleshooting Procedures - Continued.

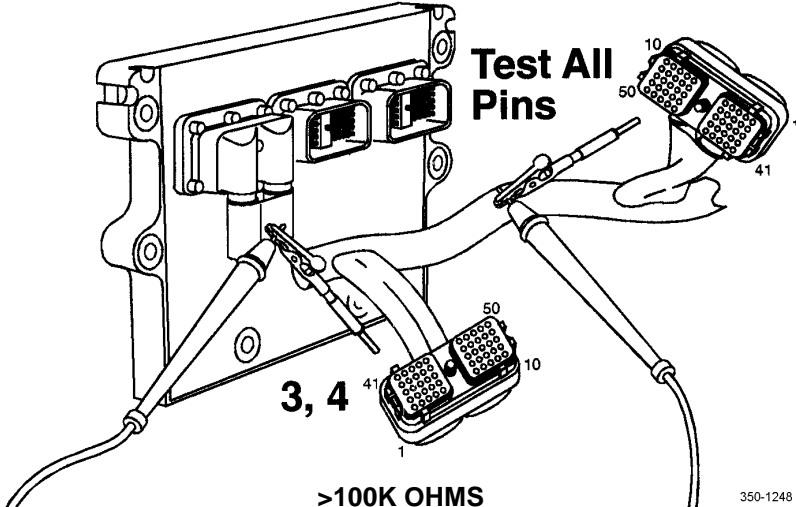
MALFUNCTION	TEST OR INSPECTION	CORRECTIVE ACTION
<p>Error Code 1323 - Injector Circuit Failure - Continued.</p>	<p>c. Measure resistance from actuator harness connector pin 4 to all pins in actuator harness connector. Resistance should be greater than 100k Ohms.</p> <p>d. Measure resistance from actuator harness connector pin 4 to all pins in sensor harness connector. Resistance should be greater than 100k Ohms.</p>	<p>a. If resistance is not as specified, repair or replace connectors (WP 0113 00).</p> <p>b. If engine harness requires replacement, notify SRA.</p> <p>a. If resistance is not as specified, repair or replace connectors (WP 0113 00).</p> <p>b. If engine harness requires replacement, notify SRA.</p>
<div style="text-align: center;">  <p>Test All Pins</p> <p>>100K OHMS</p> <p>350-1248</p> </div>		
<p>5. Place ignition switch in OFF position and disconnect actuator harness 15-pin connector at front of engine below rocker arm cover. Disconnect actuator harness connector from engine ECU.</p>		

Table 8. Error Code 1323 - Injector Circuit Failure Troubleshooting Procedures - Continued.

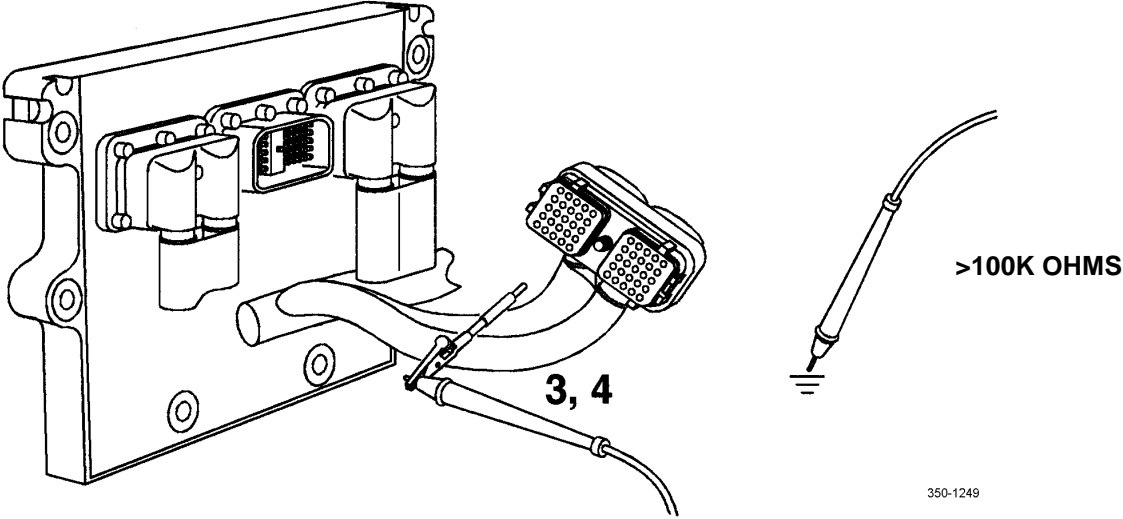
MALFUNCTION	TEST OR INSPECTION	CORRECTIVE ACTION
<p>Error Code 1323 - Injector Circuit Failure - Continued.</p>	<p>a. Measure resistance from actuator harness connector pin 3 to engine block ground. Resistance should be greater than 100k Ohms.</p> <p>b. Measure resistance from actuator harness connector pin 4 to engine block ground. Resistance should be greater than 100k Ohms.</p>	<p>a. If resistance is not as specified, repair or replace connectors (WP 0113 00).</p> <p>b. If engine harness requires replacement, notify SRA.</p> <p>a. If resistance is not as specified, repair or replace connectors (WP 0113 00).</p> <p>b. If engine harness requires replacement, notify SRA.</p>
 <p style="text-align: right; margin-right: 100px;">350-1249</p>		
<p>6. Place ignition switch in OFF position. Remove rocker arm cover (WP 0052 00). Disconnect injector solenoid connector from no. 5 injector solenoid and internal actuator harness from 15-pin connector.</p> <p>a. Inspect internal actuator harness and injector solenoid connector for dirty, corroded, bent, broken, pushed back, and extended pins.</p> <p style="text-align: right;">Clean and repair connector(s) as required (WP 0113 00).</p>		

Table 8. Error Code 1323 - Injector Circuit Failure Troubleshooting Procedures - Continued.

MALFUNCTION	TEST OR INSPECTION	CORRECTIVE ACTION
<p>Error Code 1323 - Injector Circuit Failure - Continued.</p>	<p>b. Check internal actuator harness and injector solenoid connector for dirt or moisture in or on connector and for missing or damaged connector seals.</p> <p>7. Place ignition switch in OFF position and, with rocker arm cover removed, disconnect actuator harness from 15-pin connector and injector solenoid wires from no. 5 injector solenoid.</p> <p>a. Measure resistance from 15-pin connector pin 1 (or A) to each injector pigtail nut that connects the no. 1 injector (resistance to one of these nuts must be within specifications). Resistance should be less than 10 Ohms.</p> <p>b. Measure resistance from 15-pin connector pin 2 (or B) to each injector pigtail nut that connects the no. 1 injector (resistance to one of these nuts must be within specifications). Resistance should be less than 10 Ohms.</p>	<p>Remove dirt and moisture from connector. Replace missing or damaged connector seals (WP 0113 00).</p> <p>a. If resistance is not as specified, repair or replace connectors (WP 0113 00).</p> <p>b. If internal actuator harness requires replacement, notify SRA.</p> <p>If resistance is not as specified, notify SRA to replace internal actuator harness.</p>

Table 8. Error Code 1323 - Injector Circuit Failure Troubleshooting Procedures - Continued.

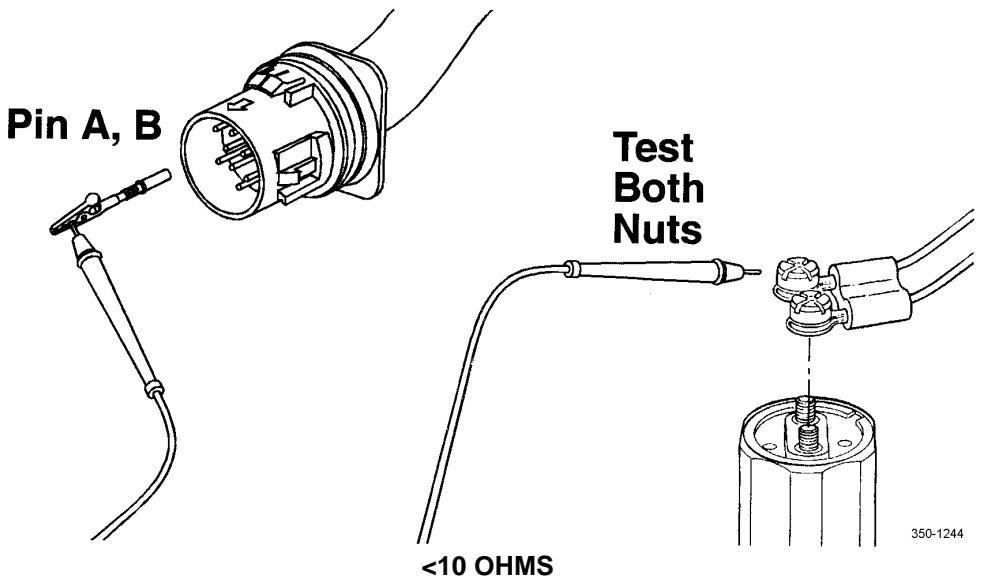
MALFUNCTION	TEST OR INSPECTION	CORRECTIVE ACTION
<p>Error Code 1323 - Injector Circuit Failure - Continued.</p> 	<p>8. Place ignition switch in OFF position and disconnect internal actuator harness from injector solenoid connector and disconnect injector solenoid wires from solenoid.</p> <p>a. Measure resistance from pin A (or 1) of injector solenoid connector to injector wire pigtail nut. Resistance should be less than 10 Ohms.</p> <p>b. Measure resistance from pin B (or 2) of injector solenoid connector to injector wire pigtail nut. Resistance should be less than 10 Ohms.</p>	<p>a. If resistance is as specified, notify SRA to replace internal actuator harness.</p> <p>b. If resistance is not as specified, replace injector solenoid wires.</p> <p>a. If resistance is as specified, notify SRA to replace internal actuator harness.</p> <p>b. If resistance is not as specified, replace injector solenoid wires.</p>

Table 8. Error Code 1323 - Injector Circuit Failure Troubleshooting Procedures - Continued.

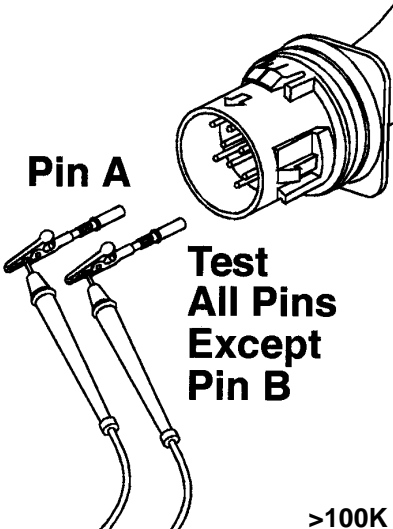
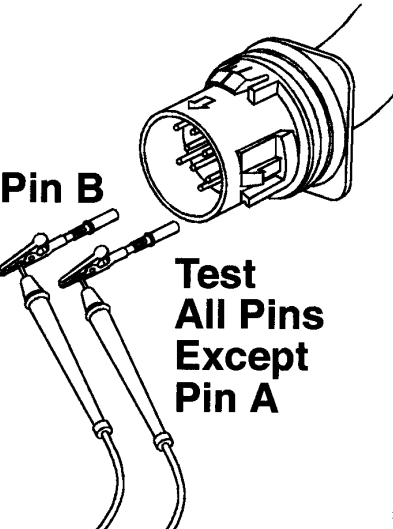
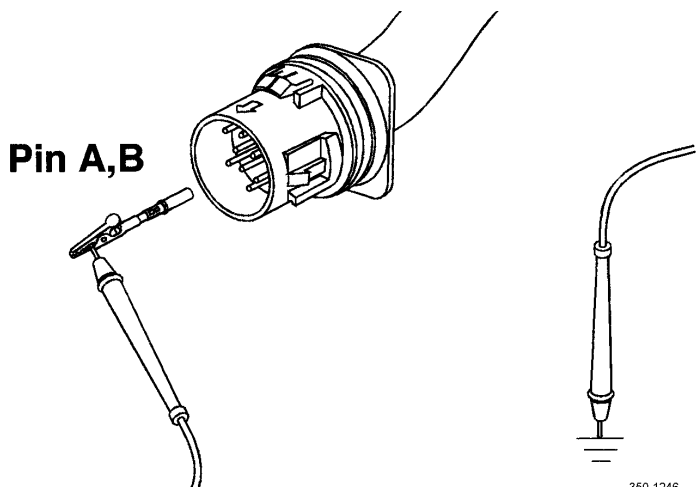
MALFUNCTION	TEST OR INSPECTION	CORRECTIVE ACTION
<p>Error Code 1323 - Injector Circuit Failure - Continued.</p>	<p>9. Place ignition switch in OFF position and, with rocker arm cover removed, disconnect internal actuator harness from 15-pin connector.</p> <p>a. Measure resistance from pin 1 (or A) on internal harness side of actuator harness 15-pin connector to all other pins in connector. Resistance should be greater than 100k Ohms.</p> <p>b. Measure resistance from pin 2 (or B) on internal harness side of actuator harness 15-pin connector to all other pins in connector. Resistance should be greater than 100k Ohms.</p>	<p>If resistance is not as specified, notify SRA to replace internal actuator harness.</p> <p>If resistance is not as specified, notify SRA to replace internal actuator harness.</p>
<div style="display: flex; justify-content: space-around; align-items: center;"> <div style="text-align: center;">  <p>Pin A Test All Pins Except Pin B</p> </div> <div style="text-align: center;">  <p>Pin B Test All Pins Except Pin A</p> </div> </div> <p style="text-align: center; margin-top: 10px;">>100K OHMS</p> <p style="text-align: right; font-size: small;">350-1245</p>		
<p>10. Place ignition switch in OFF position and, with rocker arm cover removed, disconnect injector solenoid connector on internal actuator harness from no. 5 injector solenoid.</p>		

Table 8. Error Code 1323 - Injector Circuit Failure Troubleshooting Procedures - Continued.

MALFUNCTION	TEST OR INSPECTION	CORRECTIVE ACTION
<p>Error Code 1323 - Injector Circuit Failure - Continued.</p>	<p>a. Measure resistance from pin 1 (or A) on solenoid connector to engine block ground. Resistance should be greater than 100k Ohms.</p> <p>b. Measure resistance from pin 2 (or B) on solenoid connector to engine block ground. Resistance should be greater than 100k Ohms.</p>	<p>If resistance is not as specified, notify SRA to replace internal actuator harness.</p> <p>If resistance is not as specified, notify SRA to replace internal actuator harness.</p>
 <p>350-1246</p>		
<p>>100K OHMS</p>		
	<p>11. Place ignition switch in OFF position and, with rocker arm cover removed, disconnect no. 5 injector solenoid from internal actuator harness.</p> <p>12. Measure resistance from post to post on solenoid. Resistance should be 0.5 to 1.5 Ohms.</p>	<p>a. If resistance is as specified, replace engine ECU (WP 0079 00).</p> <p>b. If resistance is not as specified, replace injector (WP 0215 00).</p>



WARNING

Injector solenoids receive high voltage when engine is operating. To avoid personal injury or death from electrical shock, do not wear jewelry or damp clothing, and do not touch injector solenoids or solenoid wires when engine is operating.

Table 9. Error Code 1324 - Injector Circuit Failure Troubleshooting Procedures.


MALFUNCTION	TEST OR INSPECTION	CORRECTIVE ACTION
<p>Error Code 1324 - Injector Circuit Failure.</p> 	<ol style="list-style-type: none"> 1. Place ignition switch in OFF position and disconnect actuator harness from engine ECU. <ol style="list-style-type: none"> a. Inspect actuator harness and ECU connector for dirty, corroded, bent, broken, pushed back, and extended pins. b. Check actuator harness and ECU connector for dirt or moisture in or on connector and for missing or damaged connector seals. 2. Place ignition switch in OFF position and disconnect actuator harness from engine ECU and 15-pin connector at front of engine below rocker arm cover. Install jumper wire from pin 5 to pin 6 at 15-pin connector, actuator harness side. 3. Measure resistance from actuator harness connector pin 6 to pin 16. Resistance should be less than 10 Ohms. 	<p>Clean and repair connector(s) as required (WP 0113 00).</p> <p>Remove dirt and moisture from connector. Replace missing or damaged connector seals (WP 0113 00).</p> <ol style="list-style-type: none"> a. If resistance is not as specified, repair or replace connectors (WP 0113 00). b. If engine harness requires replacement, notify SRA.

Table 9. Error Code 1324 - Injector Circuit Failure Troubleshooting Procedures - Continued.

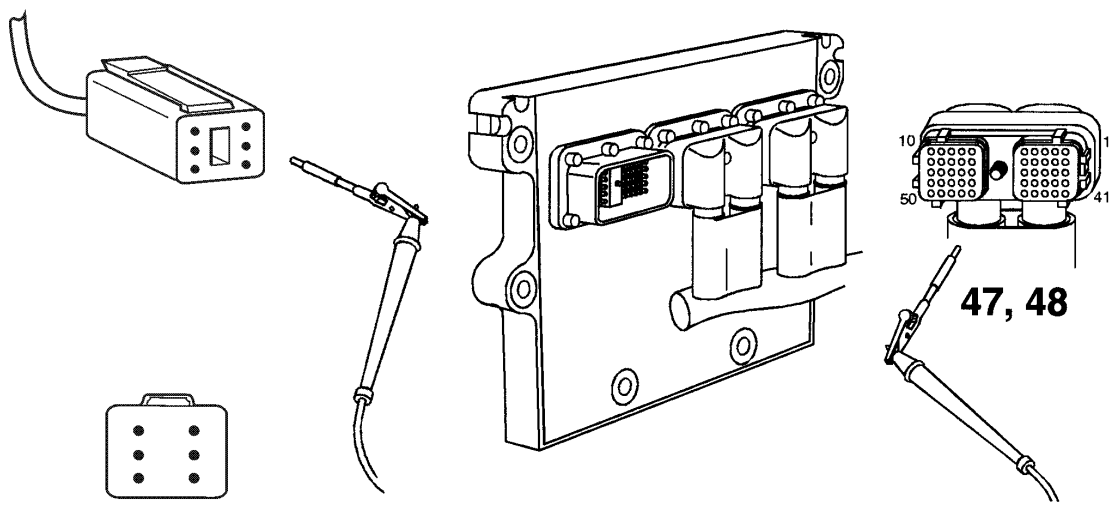
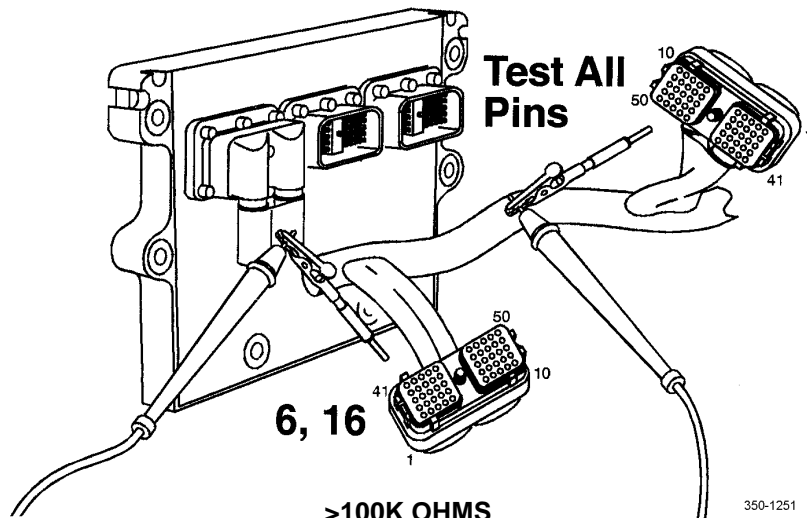
MALFUNCTION	TEST OR INSPECTION	CORRECTIVE ACTION
<p data-bbox="159 409 717 472">Error Code 1324 - Injector Circuit Failure - Continued.</p>  <p data-bbox="690 1060 836 1102"><10 OHMS</p>	<p data-bbox="730 1113 1088 1333">4. Place ignition switch in OFF position and disconnect actuator harness from engine ECU and 15-pin connector at front of engine below rocker arm cover. Disconnect sensor harness from engine ECU.</p> <p data-bbox="755 1354 1088 1543">a. Measure resistance from actuator harness connector pin 6 to all pins in actuator harness connector. Resistance should be greater than 100k Ohms.</p> <p data-bbox="755 1564 1088 1753">b. Measure resistance from actuator harness connector pin 6 to all pins in sensor harness connector. Resistance should be greater than 100k Ohms.</p>	<p data-bbox="1104 1354 1461 1512">a. If resistance is not as specified, repair or replace connectors (WP 0113 00). b. If engine harness requires replacement, notify SRA.</p> <p data-bbox="1104 1564 1461 1722">a. If resistance is not as specified, repair or replace connectors (WP 0113 00). b. If engine harness requires replacement, notify SRA.</p> <p data-bbox="1274 1081 1339 1102">350-1250</p>

Table 9. Error Code 1324 - Injector Circuit Failure Troubleshooting Procedures - Continued.

MALFUNCTION	TEST OR INSPECTION	CORRECTIVE ACTION
<p>Error Code 1324 - Injector Circuit Failure - Continued.</p>	<p>c. Measure resistance from actuator harness connector pin 16 to all pins in actuator harness connector. Resistance should be greater than 100k Ohms.</p> <p>d. Measure resistance from actuator harness connector pin 16 to all pins in sensor harness connector. Resistance should be greater than 100k Ohms.</p>	<p>a. If resistance is not as specified, repair or replace connectors (WP 0113 00).</p> <p>b. If engine harness requires replacement, notify SRA.</p> <p>a. If resistance is not as specified, repair or replace connectors (WP 0113 00).</p> <p>b. If engine harness requires replacement, notify SRA.</p>



5. Place ignition switch in OFF position and disconnect actuator harness 15-pin connector at front of engine below rocker arm cover. Disconnect actuator harness connector from engine ECU.

Table 9. Error Code 1324 - Injector Circuit Failure Troubleshooting Procedures - Continued.

MALFUNCTION	TEST OR INSPECTION	CORRECTIVE ACTION
<p>Error Code 1324 - Injector Circuit Failure - Continued.</p>	<p>a. Measure resistance from actuator harness connector pin 6 to engine block ground. Resistance should be greater than 100k Ohms.</p> <p>b. Measure resistance from actuator harness connector pin 16 to engine block ground. Resistance should be greater than 100k Ohms.</p>	<p>a. If resistance is not as specified, repair or replace connectors (WP 0113 00).</p> <p>b. If engine harness requires replacement, notify SRA.</p> <p>a. If resistance is not as specified, repair or replace connectors (WP 0113 00).</p> <p>b. If engine harness requires replacement, notify SRA.</p>

>100K OHMS

350-1252

6. Place ignition switch in OFF position. Remove rocker arm cover (WP 0052 00). Disconnect injector solenoid connector from no. 3 injector solenoid and internal actuator harness from 15-pin connector.

a. Inspect internal actuator harness and injector solenoid connector for dirty, corroded, bent, broken, pushed back, and extended pins.

Clean and repair connector(s) as required (WP 0113 00).

Table 9. Error Code 1324 - Injector Circuit Failure Troubleshooting Procedures - Continued.

MALFUNCTION	TEST OR INSPECTION	CORRECTIVE ACTION
<p>Error Code 1324 - Injector Circuit Failure - Continued.</p>	<p>b. Check internal actuator harness and injector solenoid connector for dirt or moisture in or on connector and for missing or damaged connector seals.</p> <p>7. Place ignition switch in OFF position and, with rocker arm cover removed, disconnect actuator harness from 15-pin connector and injector solenoid wires from no. 3 injector solenoid.</p> <p>a. Measure resistance from 15-pin connector pin 1 (or A) to each injector pigtail nut that connects the no. 1 injector (resistance to one of these nuts must be within specifications). Resistance should be less than 10 Ohms.</p> <p>b. Measure resistance from 15-pin connector pin 2 (or B) to each injector pigtail nut that connects the no. 1 injector (resistance to one of these nuts must be within specifications). Resistance should be less than 10 Ohms.</p>	<p>Remove dirt and moisture from connector. Replace missing or damaged connector seals (WP 0113 00).</p> <p>a. If resistance is not as specified, repair or replace connectors (WP 0113 00).</p> <p>b. If internal actuator harness requires replacement, notify SRA.</p> <p>If resistance is not as specified, notify SRA to replace internal actuator harness.</p>

Table 9. Error Code 1324 - Injector Circuit Failure Troubleshooting Procedures - Continued.

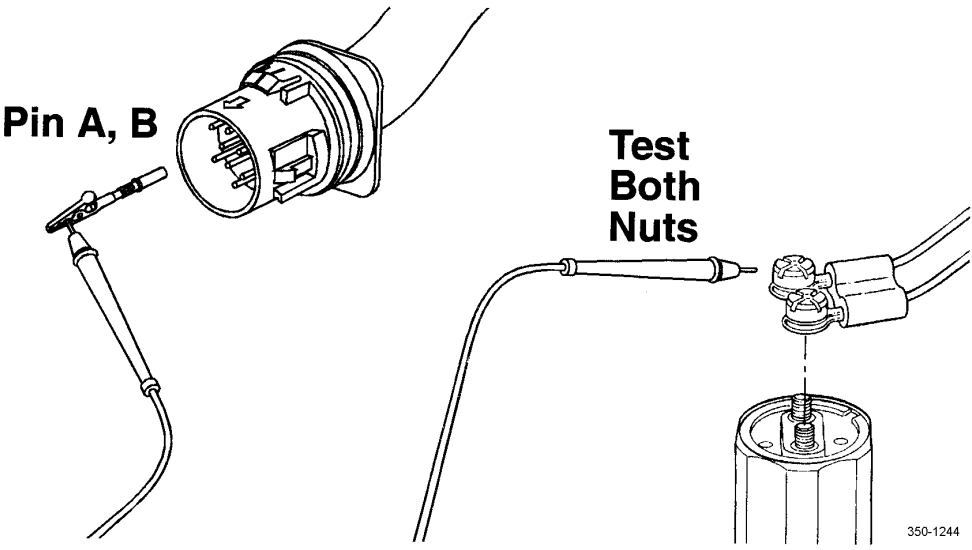
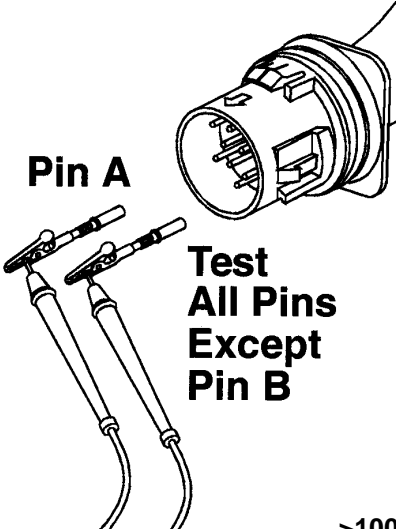
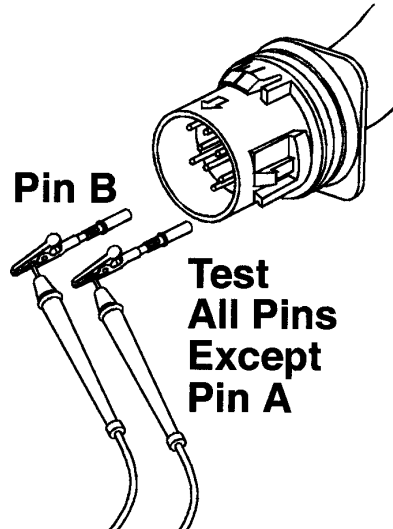
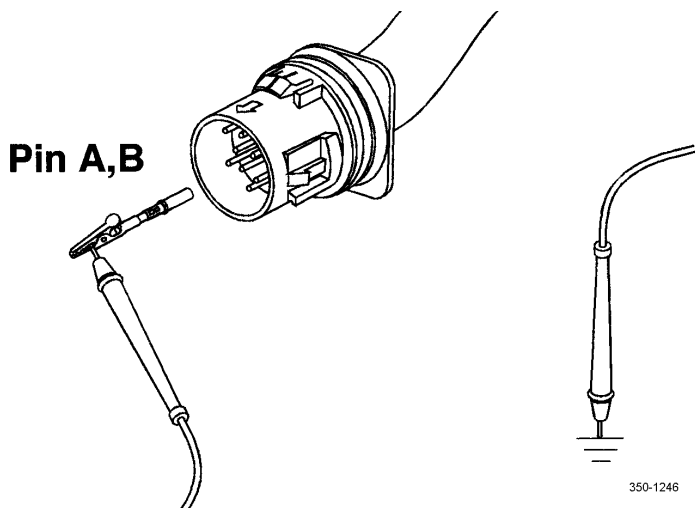
MALFUNCTION	TEST OR INSPECTION	CORRECTIVE ACTION
<p>Error Code 1324 - Injector Circuit Failure - Continued.</p>  <p style="text-align: right; margin-right: 50px;">350-1244</p>	<p style="text-align: center;">Test Both Nuts</p> <p style="text-align: center;"><10 OHMS</p> <p>8. Place ignition switch in OFF position and disconnect internal actuator harness from injector solenoid connector and disconnect injector solenoid wires from solenoid.</p> <p>a. Measure resistance from pin A (or 1) of injector solenoid connector to injector wire pigtail nut. Resistance should be less than 10 Ohms.</p> <p>b. Measure resistance from pin B (or 2) of injector solenoid connector to injector wire pigtail nut. Resistance should be less than 10 Ohms.</p>	<p>a. If resistance is as specified, notify SRA to replace internal actuator harness.</p> <p>b. If resistance is not as specified, replace injector solenoid wires.</p> <p>a. If resistance is as specified, notify SRA to replace internal actuator harness.</p> <p>b. If resistance is not as specified, replace injector solenoid wires.</p>

Table 9. Error Code 1324 - Injector Circuit Failure Troubleshooting Procedures - Continued.

MALFUNCTION	TEST OR INSPECTION	CORRECTIVE ACTION
<p>Error Code 1324 - Injector Circuit Failure - Continued.</p>	<p>9. Place ignition switch in OFF position and, with rocker arm cover removed, disconnect internal actuator harness from 15-pin connector.</p> <p>a. Measure resistance from pin 1 (or A) on internal harness side of actuator harness 15-pin connector to all other pins in connector. Resistance should be greater than 100k Ohms.</p> <p>b. Measure resistance from pin 2 (or B) on internal harness side of actuator harness 15-pin connector to all other pins in connector. Resistance should be greater than 100k Ohms.</p>	<p>If resistance is not as specified, notify SRA to replace internal actuator harness.</p> <p>If resistance is not as specified, notify SRA to replace internal actuator harness.</p>
<div style="display: flex; justify-content: space-around; align-items: center;"> <div style="text-align: center;">  <p>Pin A Test All Pins Except Pin B</p> </div> <div style="text-align: center;">  <p>Pin B Test All Pins Except Pin A</p> </div> </div> <p style="text-align: center; margin-top: 10px;">>100K OHMS</p>		
<p>10. Place ignition switch in OFF position and, with rocker arm cover removed, disconnect injector solenoid connector on internal actuator harness from no. 3 injector solenoid.</p>		

350-1245

Table 9. Error Code 1324 - Injector Circuit Failure Troubleshooting Procedures - Continued.

MALFUNCTION	TEST OR INSPECTION	CORRECTIVE ACTION
<p>Error Code 1324 - Injector Circuit Failure - Continued.</p>	<p>a. Measure resistance from pin 1 (or A) on solenoid connector to engine block ground. Resistance should be greater than 100k Ohms.</p> <p>b. Measure resistance from pin 2 (or B) on solenoid connector to engine block ground. Resistance should be greater than 100k Ohms.</p>	<p>If resistance is not as specified, notify SRA to replace internal actuator harness.</p> <p>If resistance is not as specified, notify SRA to replace internal actuator harness.</p>
 <p>350-1246</p>		
<p>>100K OHMS</p>		
<p>11. Place ignition switch in OFF position and, with rocker arm cover removed, disconnect no. 3 injector solenoid from internal actuator harness.</p> <p>12. Measure resistance from post to post on solenoid. Resistance should be 0.5 to 1.5 Ohms.</p> <p>a. If resistance is as specified, replace engine ECU (WP 0079 00).</p> <p>b. If resistance is not as specified, replace injector (WP 0215 00).</p>		



WARNING

Injector solenoids receive high voltage when engine is operating. To avoid personal injury or death from electrical shock, do not wear jewelry or damp clothing, and do not touch injector solenoids or solenoid wires when engine is operating.

Table 10. Error Code 1325 - Injector Circuit Failure Troubleshooting Procedures.


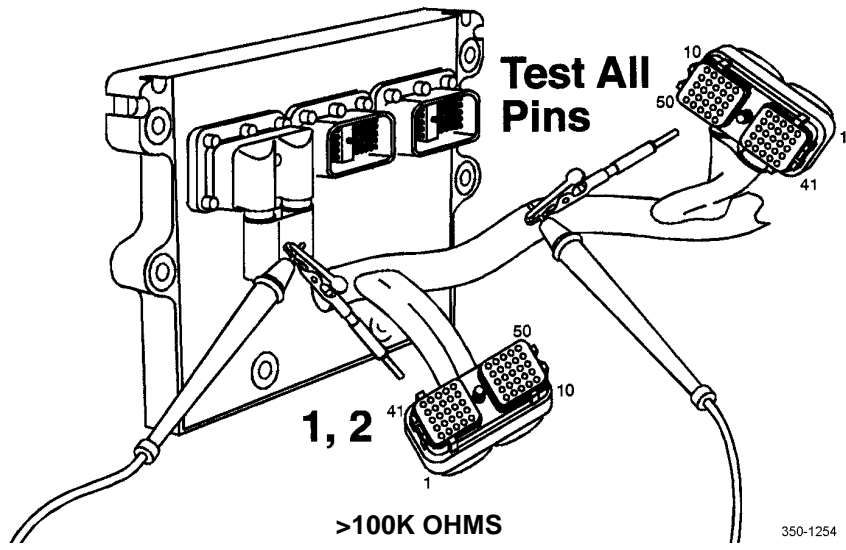
MALFUNCTION	TEST OR INSPECTION	CORRECTIVE ACTION
<p>Error Code 1325 - Injector Circuit Failure.</p> 	<ol style="list-style-type: none"> 1. Place ignition switch in OFF position and disconnect actuator harness from engine ECU. <ol style="list-style-type: none"> a. Inspect actuator harness and ECU connector for dirty, corroded, bent, broken, pushed back, and extended pins. b. Check actuator harness and ECU connector for dirt or moisture in or on connector and for missing or damaged connector seals. 2. Place ignition switch in OFF position and disconnect actuator harness from engine ECU and 15-pin connector at front of engine below rocker arm cover. Install jumper wire from pin 11 to pin 12 at 15-pin connector, actuator harness side. 3. Measure resistance from actuator harness connector pin 1 to pin 2. Resistance should be less than 10 Ohms. 	<ol style="list-style-type: none"> Clean and repair connector(s) as required (WP 0113 00). Remove dirt and moisture from connector. Replace missing or damaged connector seals (WP 0113 00). a. If resistance is not as specified, repair or replace connectors (WP 0113 00). b. If engine harness requires replacement, notify SRA.

Table 10. Error Code 1325 - Injector Circuit Failure Troubleshooting Procedures - Continued.

MALFUNCTION	TEST OR INSPECTION	CORRECTIVE ACTION
<p>Error Code 1325 - Injector Circuit Failure - Continued.</p> <div data-bbox="462 556 1136 1092" style="text-align: center;"> <p data-bbox="698 1060 836 1092"><10 OHMS</p> </div>	<p>4. Place ignition switch in OFF position and disconnect actuator harness from engine ECU and 15-pin connector at front of engine below rocker arm cover. Disconnect sensor harness from engine ECU.</p> <p>a. Measure resistance from actuator harness connector pin 1 to all pins in actuator harness connector. Resistance should be greater than 100k Ohms.</p> <p>b. Measure resistance from actuator harness connector pin 1 to all pins in sensor harness connector. Resistance should be greater than 100k Ohms.</p>	<p>a. If resistance is not as specified, repair or replace connectors (WP 0113 00).</p> <p>b. If engine harness requires replacement, notify SRA.</p> <p>a. If resistance is not as specified, repair or replace connectors (WP 0113 00).</p> <p>b. If engine harness requires replacement, notify SRA.</p>

Table 10. Error Code 1325 - Injector Circuit Failure Troubleshooting Procedures - Continued.

MALFUNCTION	TEST OR INSPECTION	CORRECTIVE ACTION
<p>Error Code 1325 - Injector Circuit Failure - Continued.</p>	<p>c. Measure resistance from actuator harness connector pin 2 to all pins in actuator harness connector. Resistance should be greater than 100k Ohms.</p> <p>d. Measure resistance from actuator harness connector pin 2 to all pins in sensor harness connector. Resistance should be greater than 100k Ohms.</p>	<p>a. If resistance is not as specified, repair or replace connectors (WP 0113 00).</p> <p>b. If engine harness requires replacement, notify SRA.</p> <p>a. If resistance is not as specified, repair or replace connectors (WP 0113 00).</p> <p>b. If engine harness requires replacement, notify SRA.</p>



5. Place ignition switch in OFF position and disconnect actuator harness 15-pin connector at front of engine below rocker arm cover. Disconnect actuator harness connector from engine ECU.

Table 10. Error Code 1325 - Injector Circuit Failure Troubleshooting Procedures - Continued.

MALFUNCTION	TEST OR INSPECTION	CORRECTIVE ACTION
<p>Error Code 1325 - Injector Circuit Failure - Continued.</p>	<p>a. Measure resistance from actuator harness connector pin 1 to engine block ground. Resistance should be greater than 100k Ohms.</p> <p>b. Measure resistance from actuator harness connector pin 2 to engine block ground. Resistance should be greater than 100k Ohms.</p>	<p>a. If resistance is not as specified, repair or replace connectors (WP 0113 00).</p> <p>b. If engine harness requires replacement, notify SRA.</p>
<p>6. Place ignition switch in OFF position. Remove rocker arm cover (WP 0052 00). Disconnect injector solenoid connector from no. 6 injector solenoid and internal actuator harness from 15-pin connector.</p> <p>a. Inspect internal actuator harness and injector solenoid connector for dirty, corroded, bent, broken, pushed back, and extended pins.</p>		
		<p>Clean and repair connector(s) as required (WP 0113 00).</p>

Table 10. Error Code 1325 - Injector Circuit Failure Troubleshooting Procedures - Continued.

MALFUNCTION	TEST OR INSPECTION	CORRECTIVE ACTION
<p>Error Code 1325 - Injector Circuit Failure - Continued.</p>	<p>b. Check internal actuator harness and injector solenoid connector for dirt or moisture in or on connector and for missing or damaged connector seals.</p> <p>7. Place ignition switch in OFF position and, with rocker arm cover removed, disconnect actuator harness from 15-pin connector and injector solenoid wires from no. 6 injector solenoid.</p> <p>a. Measure resistance from 15-pin connector pin 1 (or A) to each injector pigtail nut that connects the No. 1 injector (resistance to one of these nuts must be within specifications). Resistance should be less than 10 Ohms.</p> <p>b. Measure resistance from 15-pin connector pin 2 (or B) to each injector pigtail nut that connects the No. 1 injector (resistance to one of these nuts must be within specifications). Resistance should be less than 10 Ohms.</p>	<p>Remove dirt and moisture from connector. Replace missing or damaged connector seals (WP 0113 00).</p> <p>a. If resistance is not as specified, repair or replace connectors (WP 0113 00).</p> <p>b. If internal actuator harness requires replacement, notify SRA.</p> <p>If resistance is not as specified, notify SRA to replace internal actuator harness.</p>

Table 10. Error Code 1325 - Injector Circuit Failure Troubleshooting Procedures - Continued.

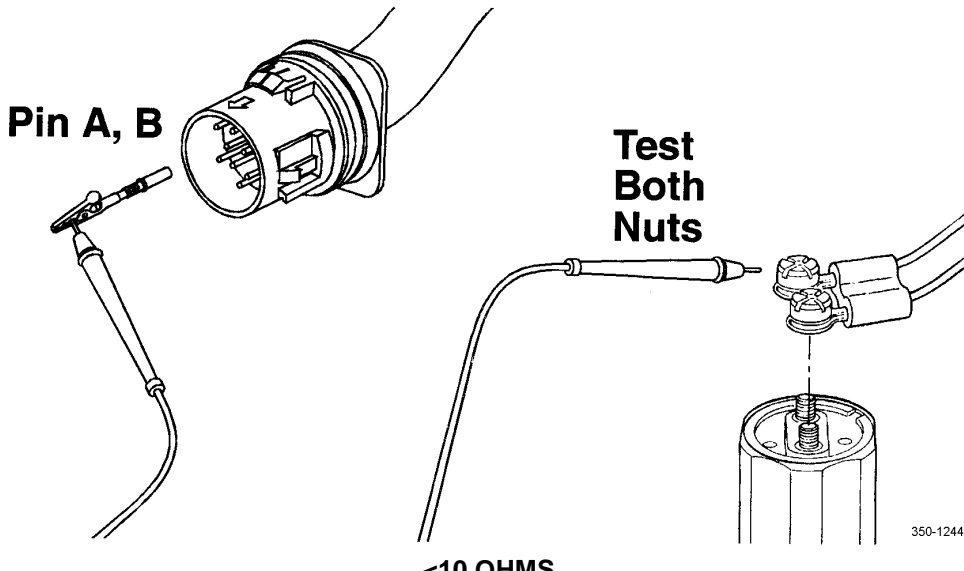
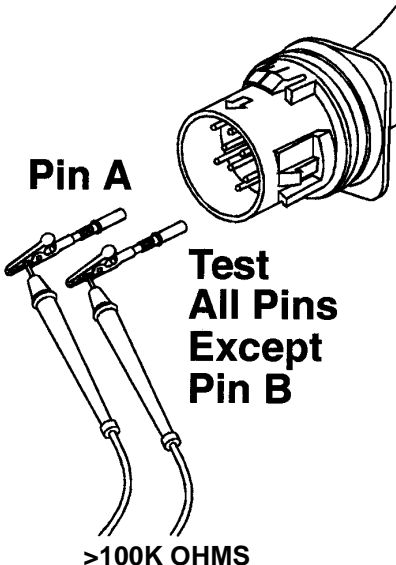
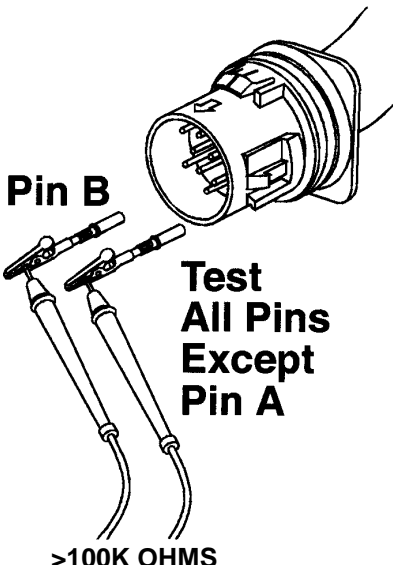
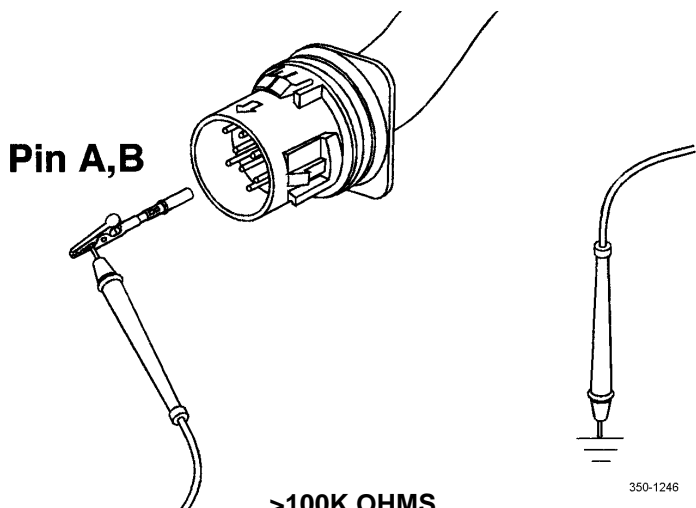
MALFUNCTION	TEST OR INSPECTION	CORRECTIVE ACTION
<p>Error Code 1325 - Injector Circuit Failure - Continued.</p>  <p style="text-align: center;"><10 OHMS</p>	<p>8. Place ignition switch in OFF position and disconnect internal actuator harness from injector solenoid connector and disconnect injector solenoid wires from solenoid.</p> <p>a. Measure resistance from pin A (or 1) of injector solenoid connector to injector wire pigtail nut. Resistance should be less than 10 Ohms.</p> <p>b. Measure resistance from pin B (or 2) of injector solenoid connector to injector wire pigtail nut. Resistance should be less than 10 Ohms.</p>	<p>a. If resistance is as specified, notify SRA to replace internal actuator harness.</p> <p>b. If resistance is not as specified, replace injector solenoid wires (WP 0113 00).</p> <p>a. If resistance is as specified, notify SRA to replace internal actuator harness.</p> <p>b. If resistance is not as specified, replace injector solenoid wires (WP 0113 00).</p>

Table 10. Error Code 1325 - Injector Circuit Failure Troubleshooting Procedures - Continued.

MALFUNCTION	TEST OR INSPECTION	CORRECTIVE ACTION
<p>Error Code 1325 - Injector Circuit Failure - Continued.</p>	<p>9. Place ignition switch in OFF position and, with rocker arm cover removed, disconnect internal actuator harness from 15-pin connector.</p> <p>a. Measure resistance from pin 1 (or A) on internal harness side of actuator harness 15-pin connector to all other pins in connector. Resistance should be greater than 100k Ohms.</p> <p>b. Measure resistance from pin 2 (or B) on internal harness side of actuator harness 15-pin connector to all other pins in connector. Resistance should be greater than 100k Ohms.</p>	<p>If resistance is not as specified, notify SRA to replace internal actuator harness.</p> <p>If resistance is not as specified, notify SRA to replace internal actuator harness.</p>
<div style="display: flex; justify-content: space-around; align-items: center;"> <div style="text-align: center;">  <p>Pin A</p> <p>Test All Pins Except Pin B</p> <p>>100K OHMS</p> </div> <div style="text-align: center;">  <p>Pin B</p> <p>Test All Pins Except Pin A</p> <p>>100K OHMS</p> </div> </div>		
<p>10. Place ignition switch in OFF position and, with rocker arm cover removed, disconnect injector solenoid connector on internal actuator harness from no. 6 injector solenoid.</p>		

350-1245

Table 10. Error Code 1325 - Injector Circuit Failure Troubleshooting Procedures - Continued.

MALFUNCTION	TEST OR INSPECTION	CORRECTIVE ACTION
<p>Error Code 1325 - Injector Circuit Failure - Continued.</p>	<p>a. Measure resistance from pin 1 (or A) on solenoid connector to engine block ground. Resistance should be greater than 100k Ohms.</p> <p>b. Measure resistance from pin 2 (or B) on solenoid connector to engine block ground. Resistance should be greater than 100k Ohms.</p>	<p>If resistance is not as specified, notify SRA to replace internal actuator harness.</p> <p>If resistance is not as specified, notify SRA to replace internal actuator harness.</p>
 <p>Pin A,B</p> <p>>100K OHMS</p> <p>350-1246</p>		
<p>11. Place ignition switch in OFF position and, with rocker arm cover removed, disconnect no. 6 injector solenoid from internal actuator harness.</p> <p>12. Measure resistance from post to post on solenoid. Resistance should be 0.5 to 1.5 Ohms.</p> <p>a. If resistance is as specified, replace engine ECU (WP 0079 00).</p> <p>b. If resistance is not as specified, replace injector (WP 0215 00).</p>		



WARNING

Injector solenoids receive high voltage when engine is operating. To avoid personal injury or death from electrical shock, do not wear jewelry or damp clothing, and do not touch injector solenoids or solenoid wires when engine is operating.

Table 11. Error Code 1331 - Injector Circuit Failure Troubleshooting Procedures.


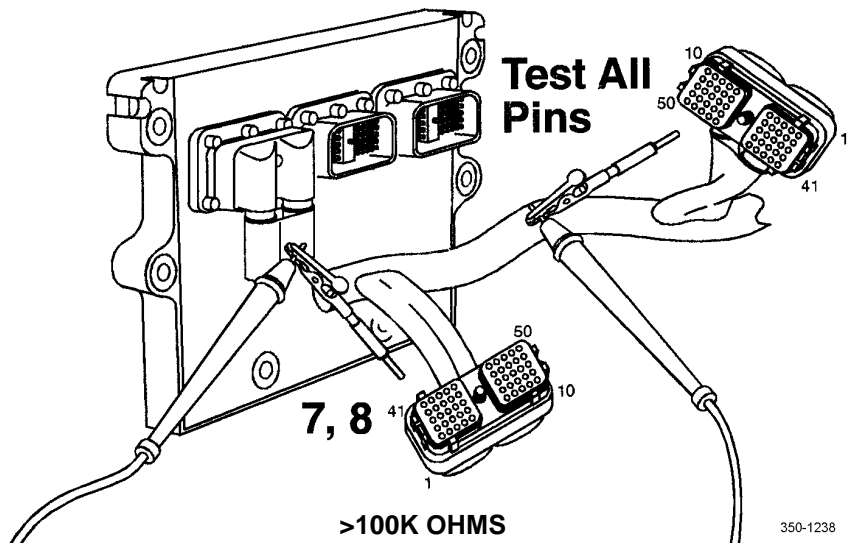
MALFUNCTION	TEST OR INSPECTION	CORRECTIVE ACTION
<p>Error Code 1331 - Injector Circuit Failure.</p> 	<ol style="list-style-type: none"> 1. Place ignition switch in OFF position and disconnect actuator harness from engine ECU. <ol style="list-style-type: none"> a. Inspect actuator harness and ECU connector for dirty, corroded, bent, broken, pushed back, and extended pins. b. Check actuator harness and ECU connector for dirt or moisture in or on connector and for missing or damaged connector seals. 2. Place ignition switch in OFF position and disconnect actuator harness from engine ECU and 15-pin connector at front of engine below rocker arm cover. Install jumper wire from pin 3 to pin 4 at 15-pin connector, actuator harness side. 3. Measure resistance from actuator harness connector pin 8 to pin 7. Resistance should be less than 10 Ohms. 	<ol style="list-style-type: none"> Clean and repair connector(s) as required (WP 0113 00). Remove dirt and moisture from connector. Replace missing or damaged connector seals (WP 0113 00). a. If resistance is not as specified, repair or replace connectors (WP 0113 00). b. If engine harness requires replacement, notify SRA.

Table 11. Error Code 1331 - Injector Circuit Failure Troubleshooting Procedures - Continued.

MALFUNCTION	TEST OR INSPECTION	CORRECTIVE ACTION
<p>Error Code 1331 - Injector Circuit Failure - Continued.</p>	<div data-bbox="479 556 1153 1081" data-label="Image"> </div> <p data-bbox="722 1060 860 1092"><10 OHMS</p> <ol style="list-style-type: none"> <li data-bbox="730 1113 1088 1333">4. Place ignition switch in OFF position and disconnect actuator harness from engine ECU and 15-pin connector at front of engine below rocker arm cover. Disconnect sensor harness from engine ECU. <ol style="list-style-type: none"> <li data-bbox="755 1354 1088 1543">a. Measure resistance from actuator harness connector pin 7 to all pins in actuator harness connector. Resistance should be greater than 100k Ohms. <li data-bbox="755 1564 1088 1753">b. Measure resistance from actuator harness connector pin 7 to all pins in sensor harness connector. Resistance should be greater than 100k Ohms. 	<ol style="list-style-type: none"> <li data-bbox="1104 1354 1461 1512">a. If resistance is not as specified, repair or replace connectors (WP 0113 00). <li data-bbox="1104 1449 1461 1512">b. If engine harness requires replacement, notify SRA. <li data-bbox="1104 1564 1461 1659">a. If resistance is not as specified, repair or replace connectors (WP 0113 00). <li data-bbox="1104 1659 1461 1722">b. If engine harness requires replacement, notify SRA.

Table 11. Error Code 1331 - Injector Circuit Failure Troubleshooting Procedures - Continued.

MALFUNCTION	TEST OR INSPECTION	CORRECTIVE ACTION
<p>Error Code 1331 - Injector Circuit Failure - Continued.</p>	<p>c. Measure resistance from actuator harness connector pin 8 to all pins in actuator harness connector. Resistance should be greater than 100k Ohms.</p> <p>d. Measure resistance from actuator harness connector pin 8 to all pins in sensor harness connector. Resistance should be greater than 100k Ohms.</p>	<p>a. If resistance is not as specified, repair or replace connectors (WP 0113 00).</p> <p>b. If engine harness requires replacement, notify SRA.</p> <p>a. If resistance is not as specified, repair or replace connectors (WP 0113 00).</p> <p>b. If engine harness requires replacement, notify SRA.</p>



5. Place ignition switch in OFF position and disconnect actuator harness 15-pin connector at front of engine below rocker arm cover. Disconnect actuator harness connector from engine ECU.

Table 11. Error Code 1331 - Injector Circuit Failure Troubleshooting Procedures - Continued.

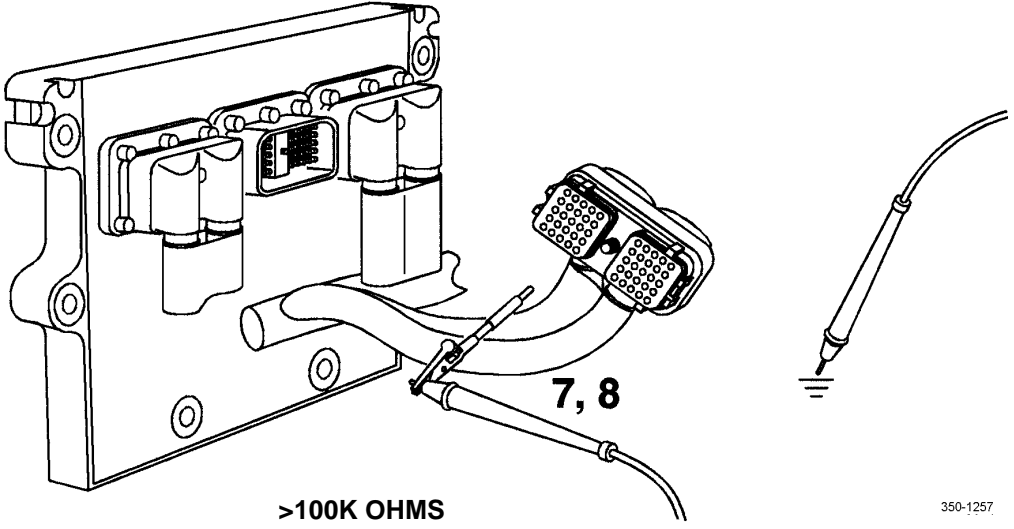
MALFUNCTION	TEST OR INSPECTION	CORRECTIVE ACTION
<p>Error Code 1331 - Injector Circuit Failure - Continued.</p> 	<p>a. Measure resistance from actuator harness connector pin 7 to engine block ground. Resistance should be greater than 100k Ohms.</p> <p>b. Measure resistance from actuator harness connector pin 8 to engine block ground. Resistance should be greater than 100k Ohms.</p> <p>6. Place ignition switch in OFF position. Remove rocker arm cover (Item , WP 0052 00)). Disconnect injector solenoid connector from no. 2 injector solenoid and internal actuator harness from 15-pin connector.</p> <p>a. Inspect internal actuator harness and injector solenoid connector for dirty, corroded, bent, broken, pushed back, and extended pins.</p>	<p>a. If resistance is not as specified, repair or replace connectors (WP 0113 00).</p> <p>b. If engine harness requires replacement, notify SRA.</p> <p>a. If resistance is not as specified, repair or replace connectors (WP 0113 00).</p> <p>b. If engine harness requires replacement, notify SRA.</p> <p>Clean and repair connector(s) as required (WP 0113 00).</p>

Table 11. Error Code 1331 - Injector Circuit Failure Troubleshooting Procedures - Continued.

MALFUNCTION	TEST OR INSPECTION	CORRECTIVE ACTION
<p>Error Code 1331 - Injector Circuit Failure - Continued.</p>	<p>b. Check internal actuator harness and injector solenoid connector for dirt or moisture in or on connector and for missing or damaged connector seals.</p> <p>7. Place ignition switch in OFF position and, with rocker arm cover removed, disconnect actuator harness from 15-pin connector and injector solenoid wires from no. 2 injector solenoid.</p> <p>a. Measure resistance from 15-pin connector pin 1 (or A) to each injector pigtail nut that connects the no. 1 injector (resistance to one of these nuts must be within specifications). Resistance should be less than 10 Ohms.</p> <p>b. Measure resistance from 15-pin connector pin 2 (or B) to each injector pigtail nut that connects the no. 1 injector (resistance to one of these nuts must be within specifications). Resistance should be less than 10 Ohms.</p>	<p>Remove dirt and moisture from connector. Replace missing or damaged connector seals (WP 0113 00).</p> <p>a. If resistance is not as specified, repair or replace connectors (WP 0113 00).</p> <p>b. If internal actuator harness requires replacement, notify SRA.</p> <p>If resistance is not as specified, notify SRA to replace internal actuator harness.</p>

Table 11. Error Code 1331 - Injector Circuit Failure Troubleshooting Procedures - Continued.

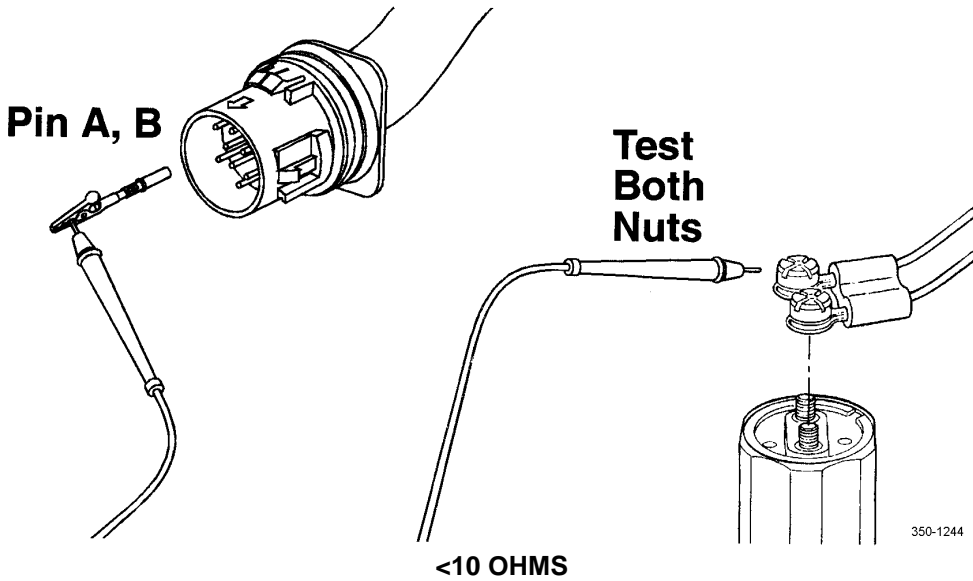
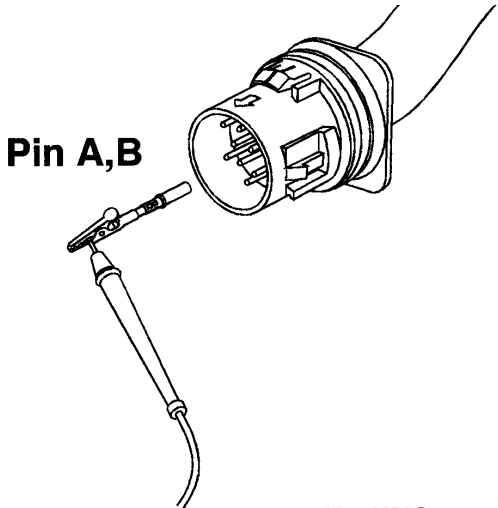
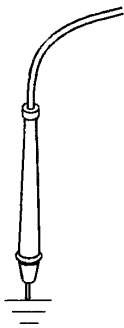
MALFUNCTION	TEST OR INSPECTION	CORRECTIVE ACTION
<p>Error Code 1331 - Injector Circuit Failure - Continued.</p> 	<p>8. Place ignition switch in OFF position and disconnect internal actuator harness from injector solenoid connector and disconnect injector solenoid wires from solenoid.</p> <p>a. Measure resistance from pin A (or 1) of injector solenoid connector to injector wire pigtail nut. Resistance should be less than 10 Ohms.</p> <p>b. Measure resistance from pin B (or 2) of injector solenoid connector to injector wire pigtail nut. Resistance should be less than 10 Ohms.</p>	<p>a. If resistance is as specified, notify SRA to replace internal actuator harness.</p> <p>b. If resistance is not as specified, replace injector solenoid wires.</p> <p>a. If resistance is as specified, notify SRA to replace internal actuator harness.</p> <p>b. If resistance is not as specified, replace injector solenoid wires.</p>

Table 11. Error Code 1331 - Injector Circuit Failure Troubleshooting Procedures - Continued.

MALFUNCTION	TEST OR INSPECTION	CORRECTIVE ACTION
<p>Error Code 1331 - Injector Circuit Failure - Continued.</p>	<p>9. Place ignition switch in OFF position and, with rocker arm cover removed, disconnect internal actuator harness from 15-pin connector.</p> <p>a. Measure resistance from pin 1 (or A) on internal harness side of actuator harness 15-pin connector to all other pins in connector. Resistance should be greater than 100k Ohms.</p> <p>b. Measure resistance from pin 2 (or B) on internal harness side of actuator harness 15-pin connector to all other pins in connector. Resistance should be greater than 100k Ohms.</p>	<p>If resistance is not as specified, notify SRA to replace internal actuator harness.</p> <p>If resistance is not as specified, notify SRA to replace internal actuator harness.</p>
<p>10. Place ignition switch in OFF position and, with rocker arm cover removed, disconnect injector solenoid connector on internal actuator harness from no. 2 injector solenoid.</p>		

350-1245

Table 11. Error Code 1331 - Injector Circuit Failure Troubleshooting Procedures - Continued.

MALFUNCTION	TEST OR INSPECTION	CORRECTIVE ACTION
<p>Error Code 1331 - Injector Circuit Failure - Continued.</p>	<p>a. Measure resistance from pin 1 (or A) on solenoid connector to engine block ground. Resistance should be greater than 100k Ohms.</p> <p>b. Measure resistance from pin 2 (or B) on solenoid connector to engine block ground. Resistance should be greater than 100k Ohms.</p>	<p>If resistance is not as specified, notify SRA to replace internal actuator harness.</p> <p>If resistance is not as specified, notify SRA to replace internal actuator harness.</p>
<div style="display: flex; justify-content: space-around; align-items: center;">   </div> <p style="text-align: center;">>100K OHMS</p>		
<p>11. Place ignition switch in OFF position and, with rocker arm cover removed, disconnect no. 2 injector solenoid from internal actuator harness.</p> <p>12. Measure resistance from post to post on solenoid. Resistance should be 0.5 to 1.5 Ohms.</p> <p>a. If resistance is as specified, replace engine ECU (WP 0079 00).</p> <p>b. If resistance is not as specified, replace injector (WP 0215 00).</p>		



WARNING

Injector solenoids receive high voltage when engine is operating. To avoid personal injury or death from electrical shock, do not wear jewelry or damp clothing, and do not touch injector solenoids or solenoid wires when engine is operating.

Table 12. Error Code 1332 - Injector Circuit Failure Troubleshooting Procedures.


MALFUNCTION	TEST OR INSPECTION	CORRECTIVE ACTION
<p>Error Code 1332 - Injector Circuit Failure.</p> 	<ol style="list-style-type: none"> 1. Place ignition switch in OFF position and disconnect actuator harness from engine ECU. <ol style="list-style-type: none"> a. Inspect actuator harness and ECU connector for dirty, corroded, bent, broken, pushed back, and extended pins. b. Check actuator harness and ECU connector for dirt or moisture in or on the connector and for missing or damaged connector seals. 2. Place ignition switch in OFF position and disconnect actuator harness from engine ECU and 15-pin connector at front of engine below rocker arm cover. Install jumper wire from pin 7 to pin 8 at 15-pin connector, actuator harness side. 3. Measure resistance from actuator harness connector pin 26 to pin 36. Resistance should be less than 10 Ohms. 	<ol style="list-style-type: none"> Clean and repair connector(s) as required (WP 0113 00). Remove dirt and moisture from connector. Replace missing or damaged connector seals (WP 0113 00). a. If resistance is not as specified, repair or replace connectors (WP 0113 00). b. If engine harness requires replacement, notify SRA.

Table 12. Error Code 1332 - Injector Circuit Failure Troubleshooting Procedures - Continued.

MALFUNCTION	TEST OR INSPECTION	CORRECTIVE ACTION
<p>Error Code 1332 - Injector Circuit Failure - Continued.</p>	<div data-bbox="479 556 1153 1081" data-label="Image"> </div> <p data-bbox="747 1081 885 1113"><10 OHMS</p> <ol style="list-style-type: none"> <li data-bbox="730 1123 1088 1354">4. Place ignition switch in OFF position and disconnect actuator harness from engine ECU and 15-pin connector at front of engine below rocker arm cover. Disconnect sensor harness from engine ECU. <ol style="list-style-type: none"> <li data-bbox="763 1365 1088 1564">a. Measure resistance from actuator harness connector pin 26 to all pins in actuator harness connector. Resistance should be greater than 100k Ohms. <li data-bbox="763 1575 1088 1774">b. Measure resistance from actuator harness connector pin 26 to all pins in sensor harness connector. Resistance should be greater than 100k Ohms. 	<ol style="list-style-type: none"> <li data-bbox="1104 1365 1461 1533">a. If resistance is not as specified, repair or replace connectors (WP 0113 00). <li data-bbox="1104 1543 1461 1732">b. If engine harness requires replacement, notify SRA. <ol style="list-style-type: none"> <li data-bbox="1104 1575 1461 1669">a. If resistance is not as specified, repair or replace connectors (WP 0113 00). <li data-bbox="1104 1680 1461 1743">b. If engine harness requires replacement, notify SRA.

Table 12. Error Code 1332 - Injector Circuit Failure Troubleshooting Procedures - Continued.

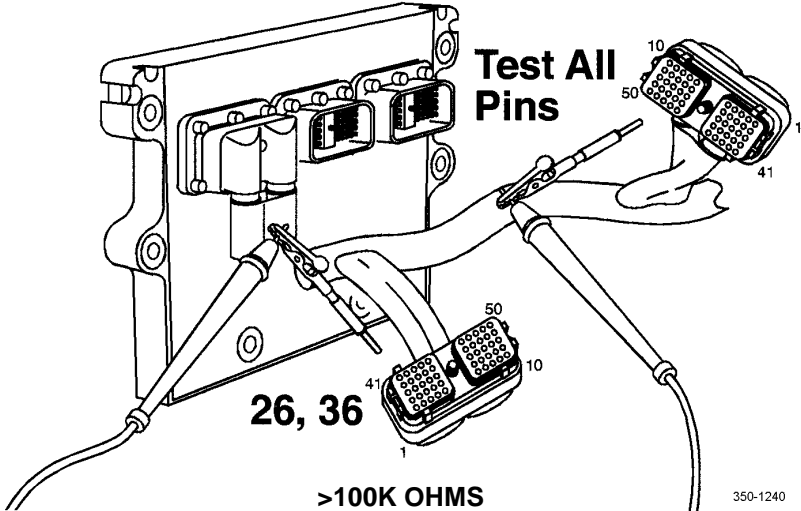
MALFUNCTION	TEST OR INSPECTION	CORRECTIVE ACTION
<p>Error Code 1332 - Injector Circuit Failure - Continued.</p>	<p>c. Measure resistance from actuator harness connector pin 36 to all pins in actuator harness connector. Resistance should be greater than 100k Ohms.</p> <p>d. Measure resistance from actuator harness connector pin 36 to all pins in sensor harness connector. Resistance should be greater than 100k Ohms.</p>	<p>a. If resistance is not as specified, repair or replace connectors (WP 0113 00).</p> <p>b. If engine harness requires replacement, notify SRA.</p> <p>a. If resistance is not as specified, repair or replace connectors (WP 0113 00).</p> <p>b. If engine harness requires replacement, notify SRA.</p>
<div style="text-align: center;">  <p>Test All Pins</p> <p>26, 36</p> <p>>100K OHMS</p> <p>350-1240</p> </div> <p>5. Place ignition switch in OFF position and disconnect actuator harness 15-pin connector at front of engine below rocker arm cover. Disconnect actuator harness connector from engine ECU.</p>		

Table 12. Error Code 1332 - Injector Circuit Failure Troubleshooting Procedures - Continued.

MALFUNCTION	TEST OR INSPECTION	CORRECTIVE ACTION
<p>Error Code 1332 - Injector Circuit Failure - Continued.</p>	<p>a. Measure resistance from actuator harness connector pin 26 to engine block ground. Resistance should be greater than 100k Ohms.</p> <p>b. Measure resistance from actuator harness connector pin 36 to engine block ground. Resistance should be greater than 100k Ohms.</p>	<p>a. If resistance is not as specified, repair or replace connectors (WP 0113 00).</p> <p>b. If engine harness requires replacement, notify SRA.</p> <p>a. If resistance is not as specified, repair or replace connectors (WP 0113 00).</p> <p>b. If engine harness requires replacement, notify SRA.</p>
<p style="text-align: center;">>100K OHMS</p> <p style="text-align: right;">350-1259</p>		
<p>6. Place ignition switch in OFF position. Remove rocker arm cover (WP 0052 00). Disconnect injector solenoid connector from no. 4 injector solenoid and internal actuator harness from 15-pin connector.</p> <p>a. Inspect internal actuator harness and injector solenoid connector for dirty, corroded, bent, broken, pushed back, and extended pins.</p> <p>Clean and repair connector(s) as required (WP 0113 00).</p>		

Table 12. Error Code 1332 - Injector Circuit Failure Troubleshooting Procedures - Continued.

MALFUNCTION	TEST OR INSPECTION	CORRECTIVE ACTION
<p>Error Code 1332 - Injector Circuit Failure - Continued.</p>	<p>b. Check internal actuator harness and injector solenoid connector for dirt or moisture in or on connector and for missing or damaged connector seals.</p> <p>7. Place ignition switch in OFF position and, with rocker arm cover removed, disconnect actuator harness from 15-pin connector and injector solenoid wires from no. 4 injector solenoid.</p> <p>a. Measure resistance from 15-pin connector pin 1 (or A) to each injector pigtail nut that connects the no. 1 injector (resistance to one of these nuts must be within specifications). Resistance should be less than 10 Ohms.</p> <p>b. Measure resistance from 15-pin connector pin 2 (or B) to each injector pigtail nut that connects the no. 1 injector (resistance to one of these nuts must be within specifications). Resistance should be less than 10 Ohms.</p>	<p>Remove dirt and moisture from connector. Replace missing or damaged connector seals (WWP 0113 00).</p> <p>a. If resistance is not as specified, repair or replace connectors (WP 0113 00).</p> <p>b. If internal actuator harness requires replacement, notify SRA.</p> <p>If resistance is not as specified, notify SRA to replace internal actuator harness.</p>

Table 12. Error Code 1332 - Injector Circuit Failure Troubleshooting Procedures - Continued.

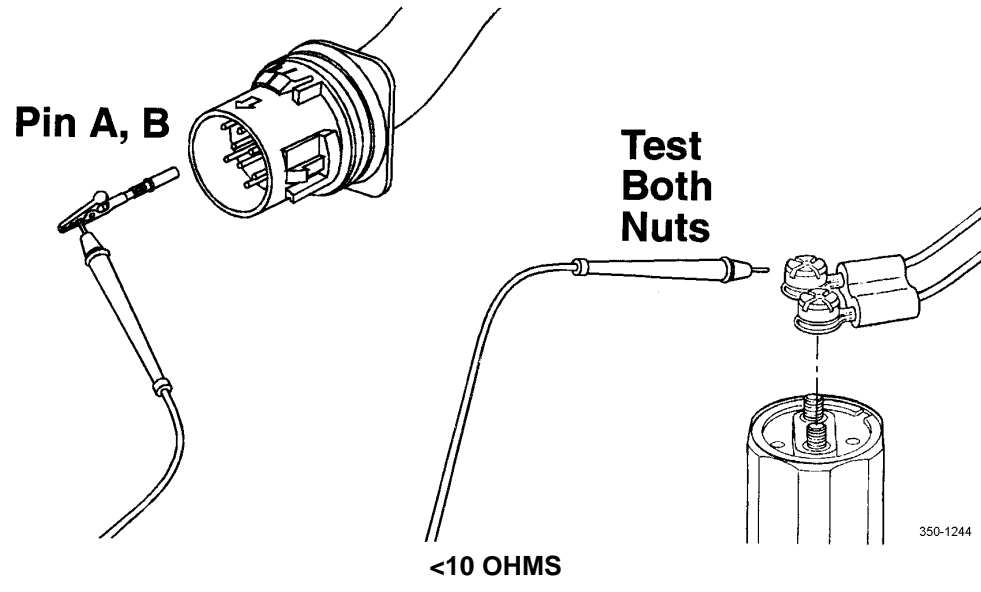
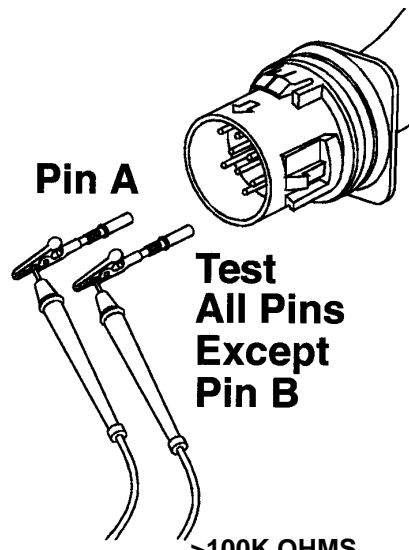
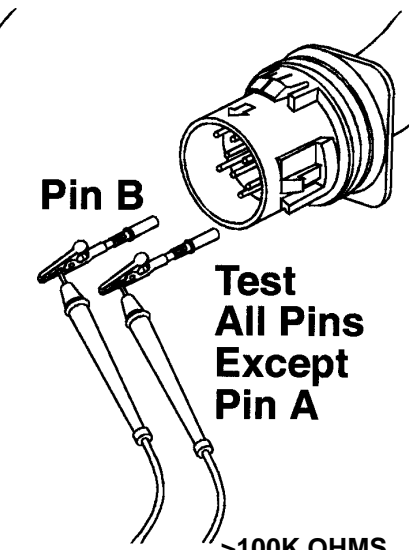
MALFUNCTION	TEST OR INSPECTION	CORRECTIVE ACTION
<p>Error Code 1332 - Injector Circuit Failure - Continued.</p> 	<p>8. Place ignition switch in OFF position and disconnect internal actuator harness from injector solenoid connector and disconnect injector solenoid wires from solenoid.</p> <p>a. Measure resistance from pin A (or 1) of injector solenoid connector to injector wire pigtail nut. Resistance should be less than 10 Ohms.</p> <p>b. Measure resistance from pin B (or 2) of injector solenoid connector to injector wire pigtail nut. Resistance should be less than 10 Ohms.</p>	<p>a. If resistance is as specified, notify SRA to replace internal actuator harness.</p> <p>b. If resistance is not as specified, replace injector solenoid wires.</p> <p>a. If resistance is as specified, notify SRA to replace internal actuator harness.</p> <p>b. If resistance is not as specified, replace injector solenoid wires.</p>

Table 12. Error Code 1332 - Injector Circuit Failure Troubleshooting Procedures - Continued.

MALFUNCTION	TEST OR INSPECTION	CORRECTIVE ACTION
<p>Error Code 1332 - Injector Circuit Failure - Continued.</p>	<p>9. Place ignition switch in OFF position and, with rocker arm cover removed, disconnect internal actuator harness from 15-pin connector.</p> <p>a. Measure resistance from pin 1 (or A) on internal harness side of actuator harness 15-pin connector to all other pins in connector. Resistance should be greater than 100k Ohms.</p> <p>b. Measure resistance from pin 2 (or B) on internal harness side of actuator harness 15-pin connector to all other pins in connector. Resistance should be greater than 100k Ohms.</p>	<p>If resistance is not as specified, notify SRA to replace internal actuator harness.</p> <p>If resistance is not as specified, notify SRA to replace internal actuator harness.</p>
<div style="display: flex; justify-content: space-around; align-items: center;"> <div style="text-align: center;">  <p>Pin A</p> <p>Test All Pins Except Pin B</p> <p>>100K OHMS</p> </div> <div style="text-align: center;">  <p>Pin B</p> <p>Test All Pins Except Pin A</p> <p>>100K OHMS</p> </div> </div>		
<p>10. Place ignition switch in OFF position and, with rocker arm cover removed, disconnect injector solenoid connector on internal actuator harness from no. 4 injector solenoid.</p>		

350-1245

Table 12. Error Code 1332 - Injector Circuit Failure Troubleshooting Procedures - Continued.

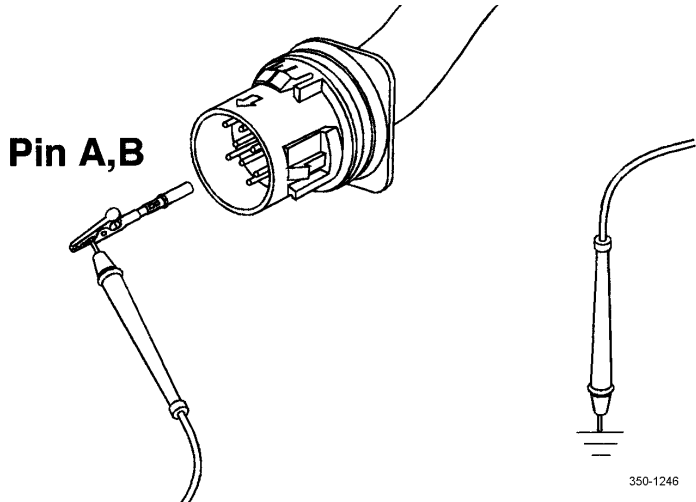

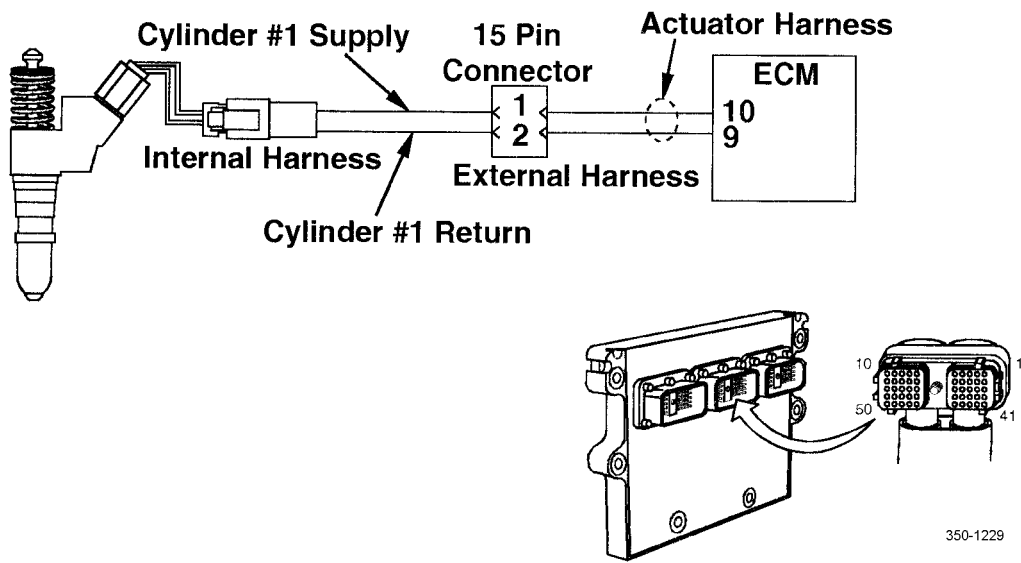
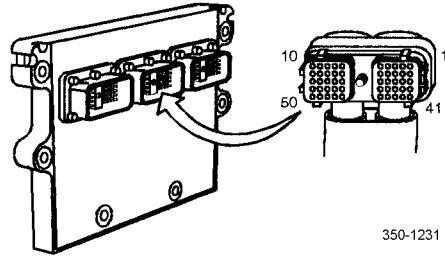
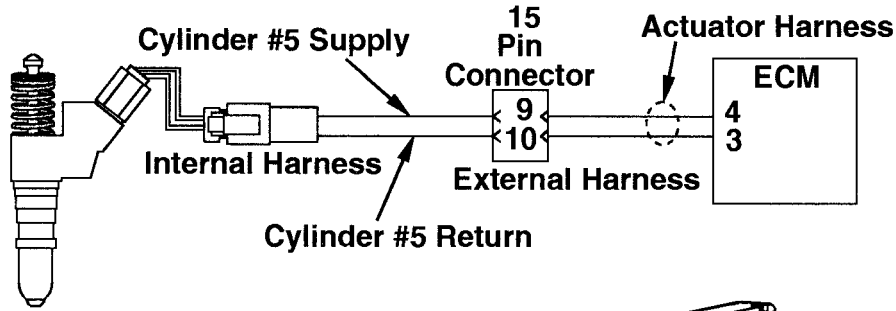
MALFUNCTION	TEST OR INSPECTION	CORRECTIVE ACTION
<p>Error Code 1332 - Injector Circuit Failure - Continued.</p>	<p>a. Measure resistance from pin 1 (or A) on solenoid connector to engine block ground. Resistance should be greater than 100k Ohms.</p> <p>b. Measure resistance from pin 2 (or B) on solenoid connector to engine block ground. Resistance should be greater than 100k Ohms.</p>	<p>If resistance is not as specified, notify SRA to replace internal actuator harness.</p> <p>If resistance is not as specified, notify SRA to replace internal actuator harness.</p>
<div style="text-align: center;">  <p>Pin A,B</p> <p>350-1246</p> </div>	<p>>100K OHMS</p> <p>11. Place ignition switch in OFF position and, with rocker arm cover removed, disconnect no. 4 injector solenoid from internal actuator harness.</p> <p>12. Measure resistance from post to post on solenoid. Resistance should be 0.5 to 1.5 Ohms.</p>	<p>a. If resistance is as specified, replace engine ECU (WP 0079 00).</p> <p>b. If resistance is not as specified, replace injector (WP 0215 00).</p>

Table 13. Error Code 1951 - Injector Circuit Failure Troubleshooting Procedures.

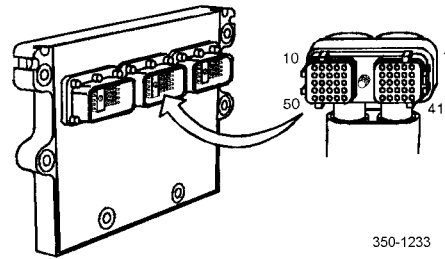
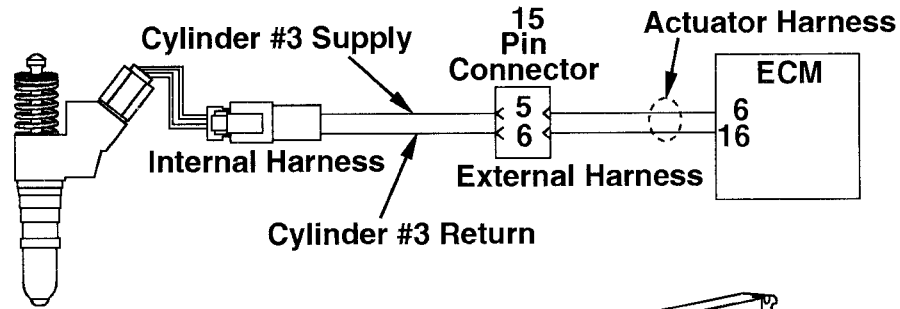
MALFUNCTION	TEST OR INSPECTION	CORRECTIVE ACTION
<p>Error Code 1951 - Injector Circuit Failure.</p> 	<p>Notify SRA.</p>	



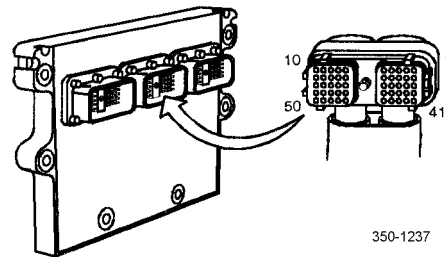
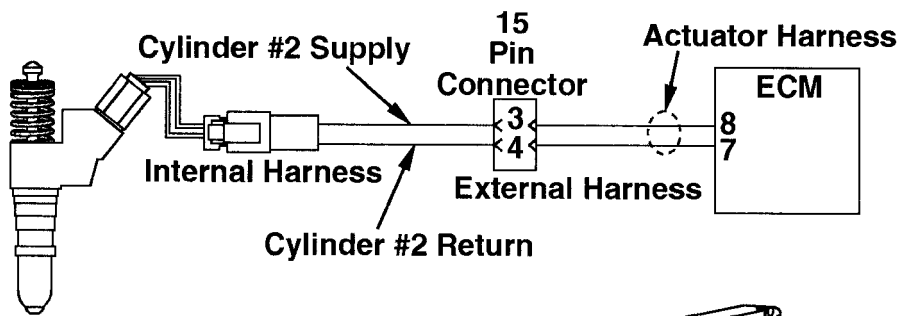
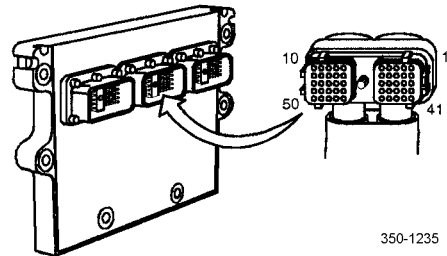
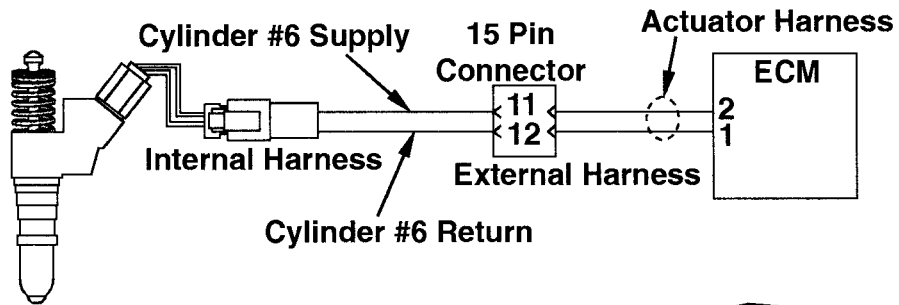
350-1229

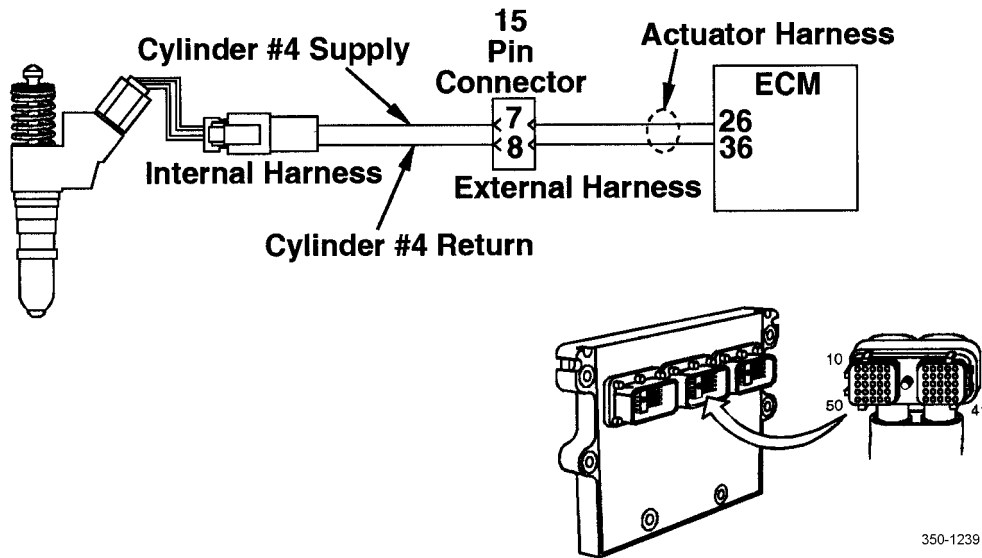


350-1231



350-1233





END OF WORK PACKAGE

THIS WORK PACKAGE COVERS

Error Code 1131 - High Voltage Detected at Throttle Position Sensor Circuit

Error Code 1132 - Throttle Position Sensor Circuit Failure

Error Code 1431 - Voltage Detected at Both Idle Validation Signal Circuits

Error Code 1432 - Accelerator Pedal Circuit Failure

Error Code 1551 - No Voltage Detected at Both Idle Validation Signal Circuits

INITIAL SETUP

Tools and Special Tools

- Test Lead, Female (Item 121, WP 0289 00)
- Test Lead, Female (Item 122, WP 0289 00)
- Test Lead, Female (Item 123, WP 0289 00)
- Test Lead, Male (Item 124, WP 0289 00)

References

TM 10-3930-675-10-1

NOTE

Refer to WP 0004 00 for additional troubleshooting guidance, information, and illustrations that locate critical components.

Table 1. Error Code 1131 - High Voltage Detected at Throttle Position Sensor Circuit Troubleshooting Procedures.


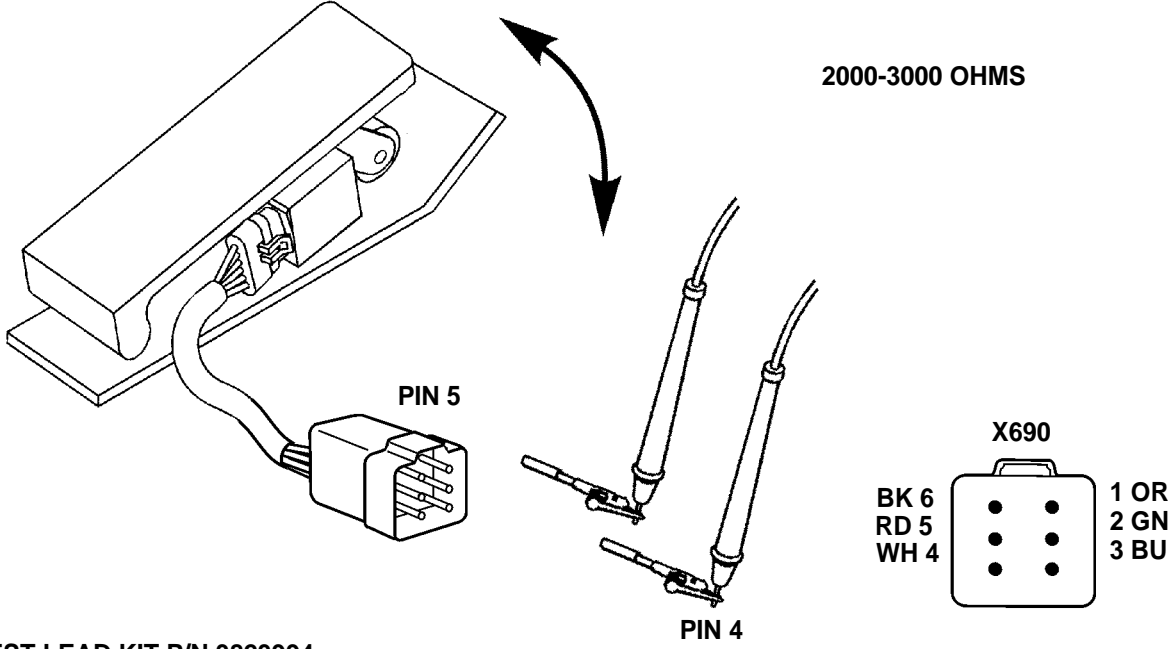
MALFUNCTION	TEST OR INSPECTION	CORRECTIVE ACTION
<p>Error Code 1131 - High Voltage Detected at Throttle Position Sensor Circuit.</p> 	<p style="text-align: center;">NOTE</p> <ul style="list-style-type: none"> • Use test lead, female - part number 3823994 (Item 122, WP 0289 00-17) to test connector X690. • Use test lead, male - part number 3822758 (Item 124, WP 0289 00-17) to test the OEM harness connector. <ol style="list-style-type: none"> 1. Inspect the accelerator pedal assembly for damage and wiring harness connection (WP 0062 00). 2. Check connector. Access the cab distribution box in the panel behind the operator's seat. Pull the box out and disconnect connector X23. 	<p>Replace damaged accelerator pedal or connect disconnected wiring harness (WP 0062 00).</p>

Table 1. Error Code 1131 - High Voltage Detected at Throttle Position Sensor Circuit Troubleshooting Procedures - Continued.

MALFUNCTION	TEST OR INSPECTION	CORRECTIVE ACTION
<p>Error Code 1131 - Throttle Position Sensor Circuit - Continued.</p>	<ol style="list-style-type: none"> 3. Inspect connector X23 for damage. Check resistance on the loose part of connector X23 between pins 4 and 5. Resistance should be 2,000 to 3,000 Ohms (WP 0048 00-11). 4. Check resistance on the loose part of connector X23 between pins 3 and 4. Resistance should be 1,500 to 3,000 Ohms with the pedal released and 250 to 1,500 Ohms with the pedal depressed (WP 0048 00-11). 5. Check connector. Remove the kick panel from in front of the steering column to access the X690 connector on the accelerator pedal wiring harness. 6. Check for continuity. Disconnect X690 and inspect for damage. Check resistance on the accelerator pedal part of connector X690 between pins 4 and 5. Check each pin for continuity to ground. Resistance should be 2,000 to 3,000 Ohms and there should be no continuity to ground (WP 0048 00-11). 	<ol style="list-style-type: none"> a. If resistance is not as specified, continue with step 4. b. Repair or replace damaged connector (WP 0113 00). <p>If resistance is not as specified, continue with step 5.</p>

Table 1. Error Code 1131 - High Voltage Detected at Throttle Position Sensor Circuit Troubleshooting Procedures - Continued.

MALFUNCTION	TEST OR INSPECTION	CORRECTIVE ACTION
<p>Error Code 1131 - Throttle Position Sensor Circuit - Continued.</p>  <p>USE TEST LEAD KIT P/N 3823994</p>	<p>7. Check resistance on the accelerator pedal part of connector X690 between pins 5 and 6. Check each pin for continuity to ground. Resistance should be 1,500 to 3,000 Ohms with the pedal released and 250 to 1,500 Ohms with the pedal depressed. There should be continuity to ground (WP 0048 00-11).</p>	<p>a. If resistance is not as specified, replace accelerator pedal assembly (WP 0062 00). b. If resistance is as specified, check continuity and for continuity to ground for wires 233, 234, and 235 (WP 0048 00-11). c. Repair or replace damaged connector (WP 0113 00). d. Replace damaged, open, shorted, or grounded X690 to X23 wiring harness (WP 0113 00).</p>

350-1261

Table 1. Error Code 1131 - High Voltage Detected at Throttle Position Sensor Circuit Troubleshooting Procedures - Continued.

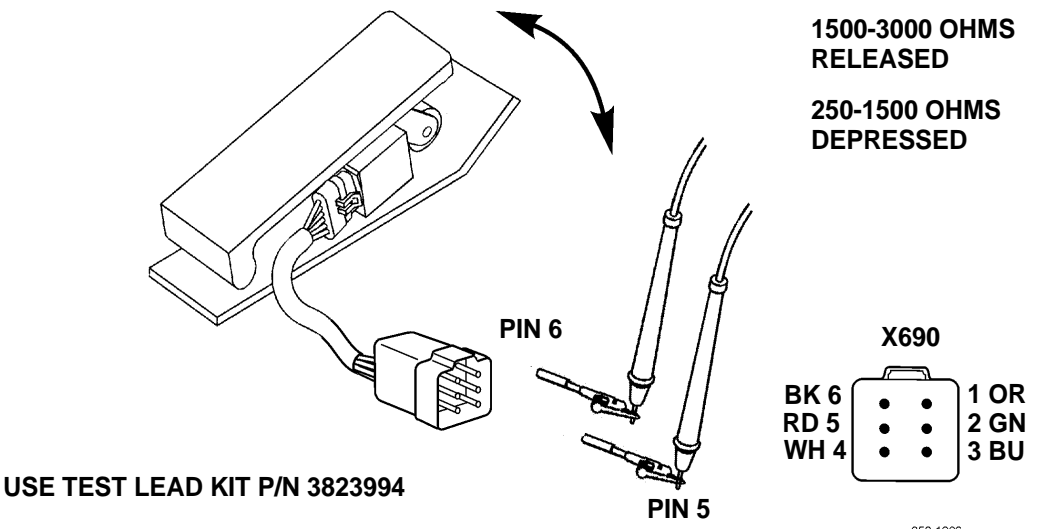
MALFUNCTION	TEST OR INSPECTION	CORRECTIVE ACTION
<p>Error Code 1131 - High Voltage Detected at Throttle Position Sensor Circuit - Continued.</p>  <p>USE TEST LEAD KIT P/N 3823994</p> <p>1500-3000 OHMS RELEASED</p> <p>250-1500 OHMS DEPRESSED</p> <p>X690</p> <p>BK 6 RD 5 WH 4</p> <p>1 OR 2 GN 3 BU</p> <p>350-1262</p>	<p>8. Inspect pins. Reconnect connector X23 and connector X690. Remove the engine cover (WP 0148 00). Disconnect the OEM harness connector from ECU (794) (WP 0080 00). Inspect the OEM harness connector and ECU pins for damage, dirt, or corrosion.</p>	<p>a. Clean and repair connector as required (WP 0113 00). b. Replace damaged ECU (794) (WP 0080 00).</p>

Table 1. Error Code 1131 - High Voltage Detected at Throttle Position Sensor Circuit Troubleshooting Procedures - Continued.

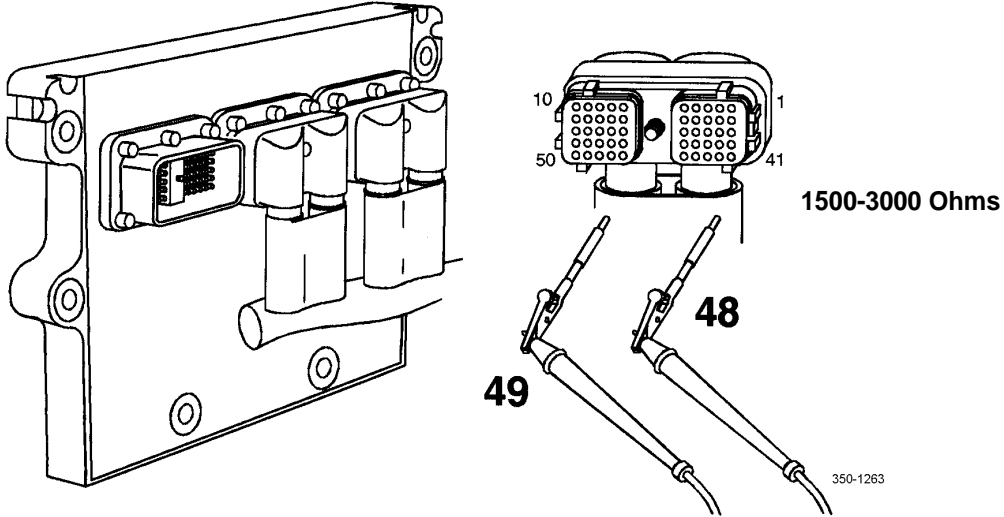
MALFUNCTION	TEST OR INSPECTION	CORRECTIVE ACTION
<p data-bbox="159 438 716 499">Error Code 1131 - High Voltage Detected at Throttle Position Sensor Circuit - Continued.</p>  <p data-bbox="164 1079 570 1108">USE TEST LEAD KIT P/N 3822758</p>		

Table 1. Error Code 1131 - High Voltage Detected at Throttle Position Sensor Circuit Troubleshooting Procedures - Continued.

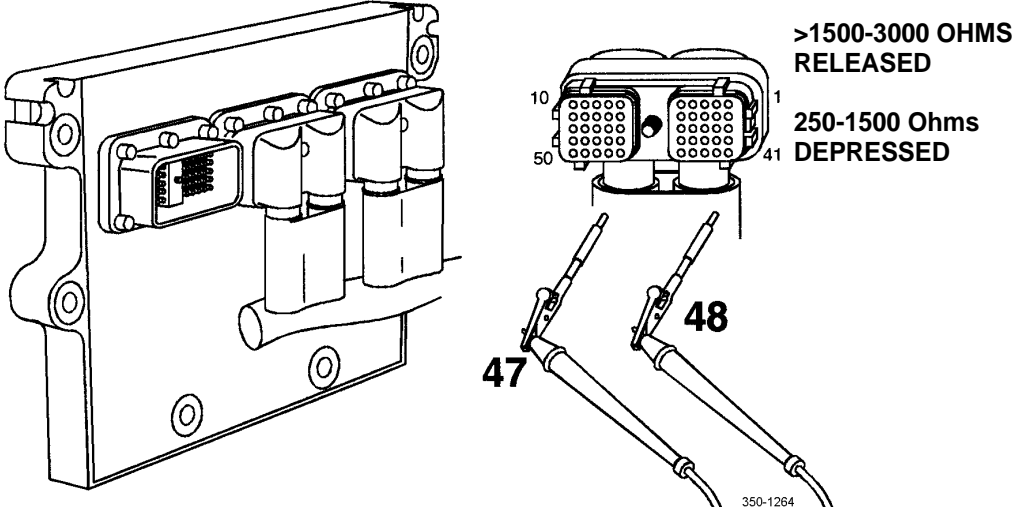
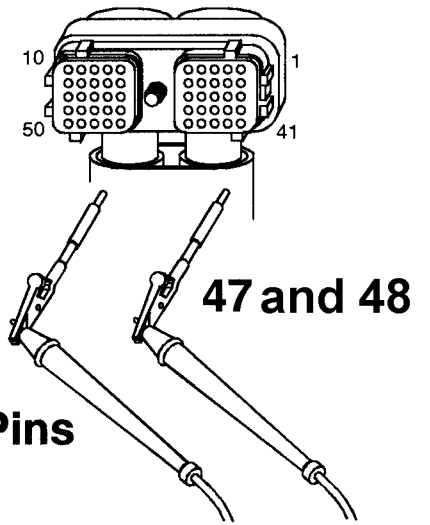
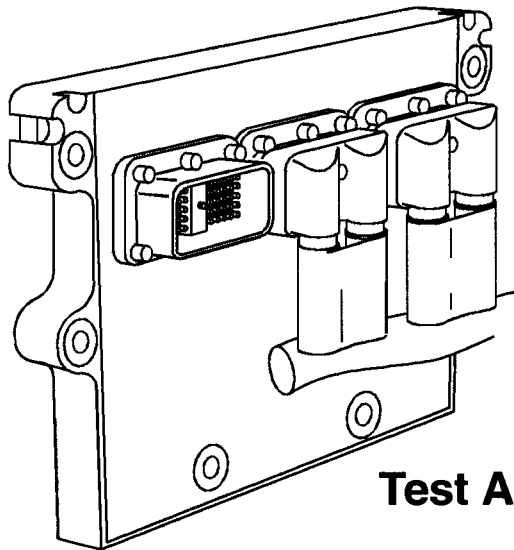
MALFUNCTION	TEST OR INSPECTION	CORRECTIVE ACTION
<p>Error Code 1131 - High Voltage Detected at Throttle Position Sensor Circuit - Continued.</p>  <p>USE TEST LEAD KIT P/N 3822758</p>	<p>9. Check resistance at the OEM harness connector between pins 48 and 49. Resistance should be 2,000 to 3,000 Ohms (WP 0048 00-11).</p> <p>10. Check resistance at the OEM harness connector between pins 47 and 48. Resistance should be 1,500 to 3,000 Ohms with the pedal released and 250 to 1,500 Ohms with the pedal depressed (WP 0048 00-11).</p>	<p>If resistance is not as specified, proceed with step 10.</p> <p>If resistance is not as specified, proceed with step 11.</p>
	<p>11. Check for continuity. Disconnect connector X16 and the OEM harness connector. Check continuity and for continuity to ground for wires 163, 164, and 165 (WP 0048 00-11).</p>	<p>If continuity to ground is found at any one wire or any wire is found to be open, replace engine and transmission wiring harness (WP 0113 00).</p>

Table 1. Error Code 1131 - High Voltage Detected at Throttle Position Sensor Circuit Troubleshooting Procedures - Continued.

MALFUNCTION	TEST OR INSPECTION	CORRECTIVE ACTION
<p>Error Code 1131 - High Voltage Detected at Throttle Position Sensor Circuit - Continued.</p>	<p>12. Check for continuity. Disconnect connector X16 and inspect for damage. Check continuity and for continuity to ground for wires A163, A164, and A165 (WP 0048 00-11).</p> <p>13. Check for continuity. Disconnect the OEM harness connector and connector X16. Check for continuity on the OEM harness connector between pin 47 and all of the other pins in the connector. There should be continuity between pins.</p>	<p>a. Repair or replace damaged connector (WP 0113 00).</p> <p>b. Replace any damaged, open, or grounded wires.</p> <p>If there is continuity between pin 47 and any other pin in the OEM harness connector, replace the engine and transmission wiring harness (WP 0113 00).</p>



Test All Pins

434-40015

Table 2. Error Code 1132 - Low Voltage Detected at Throttle Position Sensor Circuit Troubleshooting Procedures.


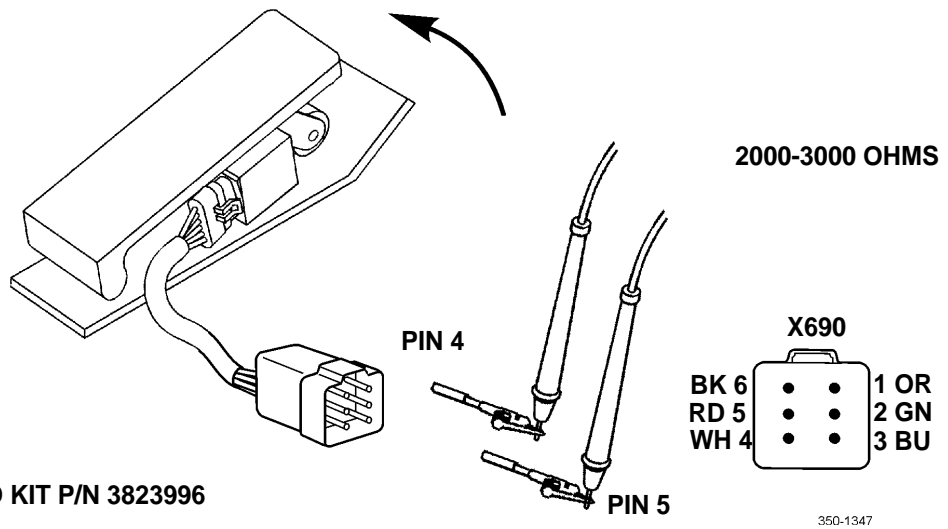
MALFUNCTION	TEST OR INSPECTION	CORRECTIVE ACTION
<p data-bbox="147 432 724 499">Error Code 1132 - Low Voltage Detected at Throttle Position Sensor Circuit.</p> 	<p data-bbox="1045 432 1146 468" style="text-align: center;">NOTE</p> <ul style="list-style-type: none"> <li data-bbox="781 485 1414 548">• Use test lead, female - part number 3823994 (Item 122, WP 0289 00-17) to test connector X690. <li data-bbox="781 562 1414 653">• Use test lead, male - part number 3822758 (Item 124, WP 0289 00-17) to test OEM harness connector. <ol style="list-style-type: none"> <li data-bbox="735 674 1089 800">1. Inspect the accelerator pedal assembly for damage and wiring harness connection (WP 0062 00). <li data-bbox="735 821 1089 968">2. Check connector. Access the cab distribution box in the panel behind the operator's seat. Pull the box out and disconnect connector X23. <li data-bbox="735 989 1089 1178">3. Inspect connector X23 for damage. Check resistance on the loose part of connector X23 between pins 4 and 5. Resistance should be 2,000 to 3,000 Ohms (WP 0048 00-11). <li data-bbox="735 1199 1089 1388">4. Check continuity on the loose part of connector X23 between pin 3 and ground and pin 4 and ground. There should be continuity to ground (WP 0048 00-11). <li data-bbox="735 1409 1089 1598">5. Inspect wiring. Remove the kick panel from in front of the steering column to access the X690 connector on the accelerator pedal wiring harness. 	<p data-bbox="1105 674 1430 768">Replace damaged accelerator pedal or connect disconnected wiring harness (WP 0062 00).</p> <p data-bbox="1105 989 1430 1115">If resistance is not as specified, continue with step 4. Repair or replace damaged connector (WP 0113 00).</p> <p data-bbox="1105 1199 1446 1262">If continuity to ground is found, continue with step 5.</p>

Table 2. Error Code 1132 - Low Voltage Detected at Throttle Position Sensor Circuit Troubleshooting Procedures - Continued.

MALFUNCTION	TEST OR INSPECTION	CORRECTIVE ACTION
<p>Error Code 1132 - Low Voltage Detected at Throttle Position Sensor Circuit - Continued.</p>	<p>6. Check for continuity. Disconnect connector X690 and inspect for damage. Check resistance on the acceleration pedal part of connector X690 between pins 4 and 5. Check each pin for continuity to ground. Resistance should be 2,000 to 3,000 Ohms and there should not be continuity to ground (WP 0048 00-11).</p>	<p>a. If resistance is not as specified; replace accelerator pedal assembly (WP 0062 00). b. Repair or replace damaged connector (WP 0113 00).</p>



USE TEST LEAD KIT P/N 3823996

Table 2. Error Code 1132 - Low Voltage Detected at Throttle Position Sensor Circuit Troubleshooting Procedures - Continued.

MALFUNCTION	TEST OR INSPECTION	CORRECTIVE ACTION
<p>Error Code 1132 - Low Voltage Detected at Throttle Position Sensor Circuit - Continued.</p>	<p>7. Check continuity on the accelerator pedal part of connector X690 between pin 5 and ground and pin 6 and ground. There should be continuity to ground (WP 0048 00-11).</p>	<p>a. If continuity to ground is found, replace accelerator pedal assembly (WP 0062 00). b. If continuity to ground is not found, check continuity and for continuity to ground for wires 233, 234, and 235 (WP 0048 00-11). c. Repair or replace damaged connector (WP 0113 00). d. Replace damaged, open, shorted, or grounded X690 to X23 wiring harness (WP 0113 00).</p>

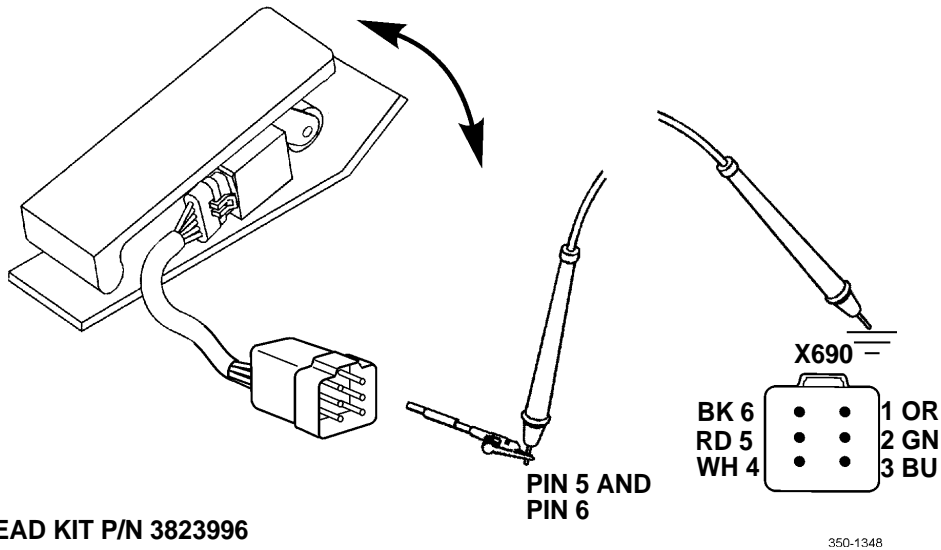
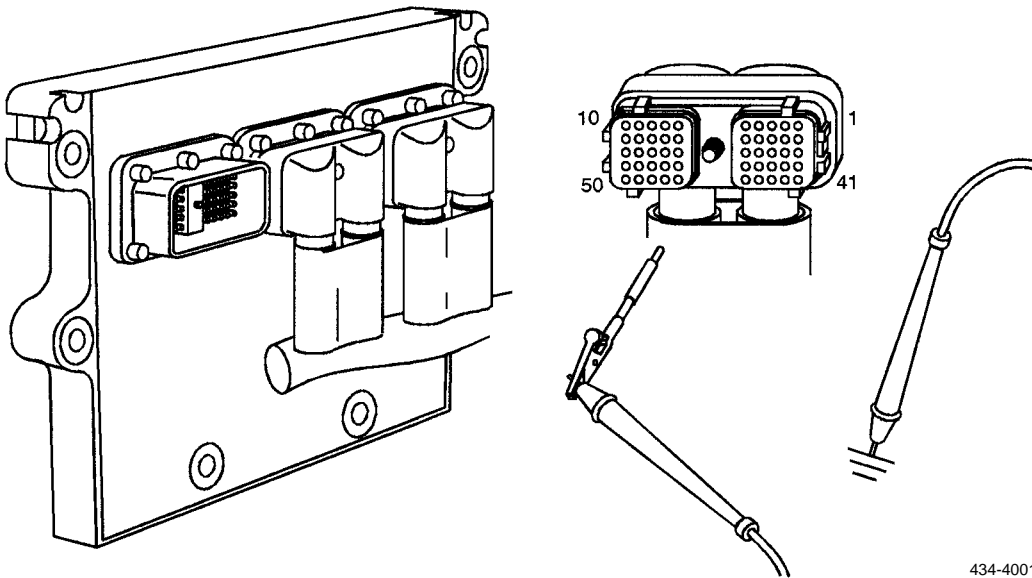


Table 2. Error Code 1132 - Low Voltage Detected at Throttle Position Sensor Circuit Troubleshooting Procedures - Continued.

MALFUNCTION	TEST OR INSPECTION	CORRECTIVE ACTION
<p>Error Code 1132 - Low Voltage Detected at Throttle Position Sensor Circuit - Continued.</p>	<p>8. Inspect pins. Remove the engine cover (WP 0148 00). Disconnect the OEM harness connector from ECU (794) (WP 0080 00). Inspect the OEM harness connector and ECU pins for damage, dirt, or corrosion.</p> <p>9. Check for continuity. Disconnect connector X16 and the OEM harness connector. Check continuity and for continuity to ground for wires 163, 164, and 165 (WP 0048 00-11).</p> <p>10. Check for continuity. Disconnect connector X16 and inspect for damage. Check continuity and for continuity to ground for wires A163, A164, and A165 (WP 0048 00-11).</p>	<p>a. Clean and repair connector as required (WP 0113 00). b. Replace damaged ECU (794) (WP 0080 00).</p> <p>If continuity to ground is found at any one wire or any wire is found to be open, replace engine and transmission wiring harness (WP 0113 00).</p> <p>a. Repair or replace damaged connector (WP 0113 00). b. Replace any damaged, open or grounded wires.</p>



434-40014

Table 2. Error Code 1132 - Low Voltage Detected at Throttle Position Sensor Circuit Troubleshooting Procedures - Continued.

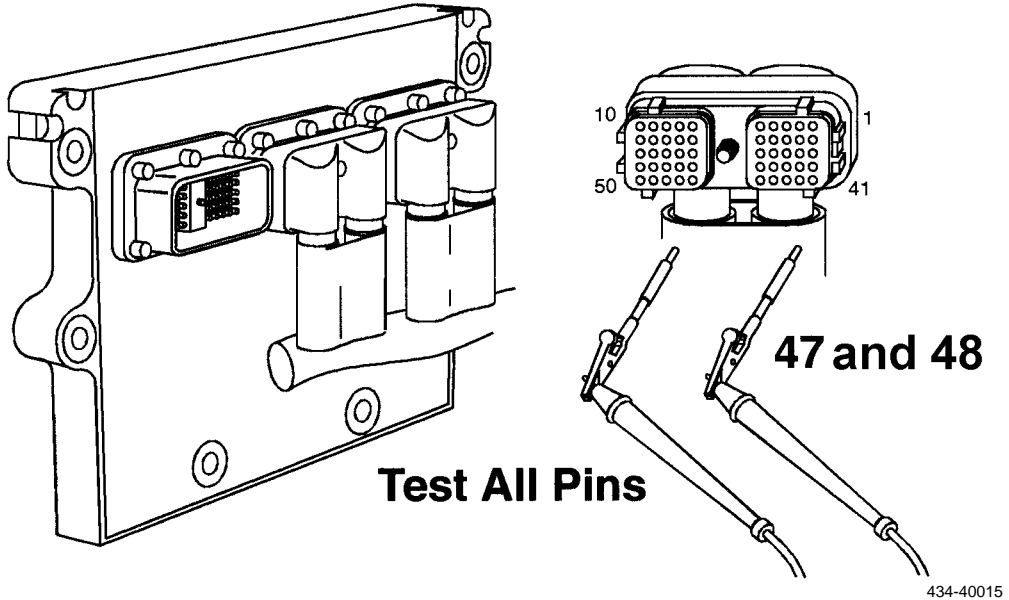
MALFUNCTION	TEST OR INSPECTION	CORRECTIVE ACTION
<p>Error Code 1132 - Low Voltage Detected at Throttle Position Sensor Circuit - Continued.</p> 	<p>11. Check for continuity. Disconnect the OEM harness connector and connector X16. Check for continuity on the OEM harness connector between pin 47 and all of the other pins in the connector and between pin 48 and all of the other pins in the connector. There should be continuity between pins.</p>	<p>If there is continuity between pin 47 or 48 and any other pin in the OEM harness connector, replace the engine and transmission wiring harness (WP 0113 00).</p>

Table 3. Error Code 1431 - Voltage Detected at Both Idle Validation Signal Circuits Troubleshooting Procedures.


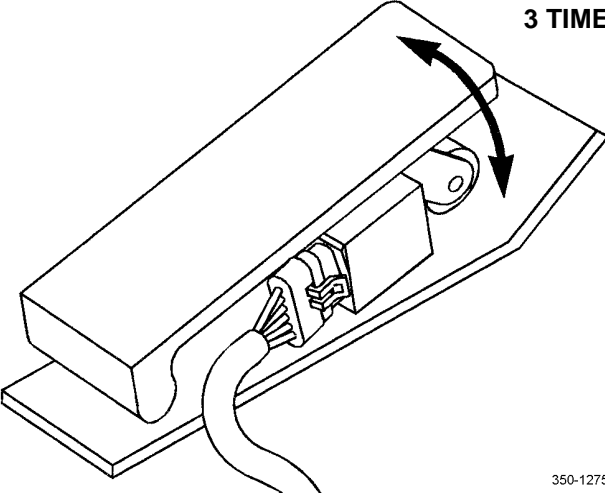
MALFUNCTION	TEST OR INSPECTION	CORRECTIVE ACTION
<p data-bbox="162 441 714 504">Error Code 1431 - Voltage Detected at Both Idle Validation Signal Circuits.</p> 	<p data-bbox="1047 441 1144 472" style="text-align: center;">NOTE</p> <ul style="list-style-type: none"> <li data-bbox="779 493 1412 556">• Use test lead, female - part number 3823994 (Item 122, WP 0289 00-17) to test connector X690. <li data-bbox="779 567 1412 651">• Use test lead, male - part number 3822758 (Item 124, WP 0289 00-17) to test the OEM harness connector. <p data-bbox="730 693 1088 850">1. Check calibration. Turn the ignition on and depress and release the accelerator pedal three times to calibrate the pedal.</p>  <p data-bbox="1031 924 1136 955" style="text-align: right;">3 TIMES</p> <p data-bbox="1055 1396 1120 1417" style="text-align: right;"><small>350-1275</small></p> <p data-bbox="730 1438 1088 1564">2. Inspect the accelerator pedal assembly for damage and wiring harness connection (WP 0062 00).</p> <p data-bbox="730 1585 1088 1774">3. Inspect connector X23 for damage. Access the cab distribution box in the panel behind the operator's seat. Pull the box out and disconnect connector X23.</p>	<p data-bbox="1104 693 1453 756">If ERROR CODE remains active, continue with step 2.</p> <p data-bbox="1104 1438 1429 1543">Replace damaged accelerator pedal or connect disconnected wiring harness (WP 0062 00).</p> <p data-bbox="1104 1585 1396 1648">Repair or replace damaged connector (WP 0113 00).</p>

Table 3. Error Code 1431 - Voltage Detected at Both Idle Validation Signal Circuits Troubleshooting Procedures - Continued.

MALFUNCTION	TEST OR INSPECTION	CORRECTIVE ACTION
<p>Error Code 1431 - Voltage Detected at Both Idle Validation Signal Circuits - Continued.</p>	<p>4. Check resistance on the loose part of connector X23 between pins 6 and 9. Resistance should be <125 Ohms with the pedal released. Check resistance between 7 and 9. Resistance should be <125 Ohms with the pedal depressed (WP 0048 00-11).</p> <p>5. Check continuity on the loose part of connector X23 between pins 6 and 7 while depressing and releasing the pedal. There should be continuity (WP 0048 00-11).</p> <p>6. Check for resistance. Remove the kick panel from in front of the steering column to access the X690 connector on the accelerator pedal wiring harness.</p>	<p>If resistance is not as specified, continue with step 5.</p> <p>If resistance is not as specified, continue with step 6.</p> <p>a. If resistance is not as specified, replace accelerator pedal assembly (WP 0062 00). b. Repair or replace damaged connector (WP 0113 00).</p>

Table 3. Error Code 1431 - Voltage Detected at Both Idle Validation Signal Circuits Troubleshooting Procedures - Continued.

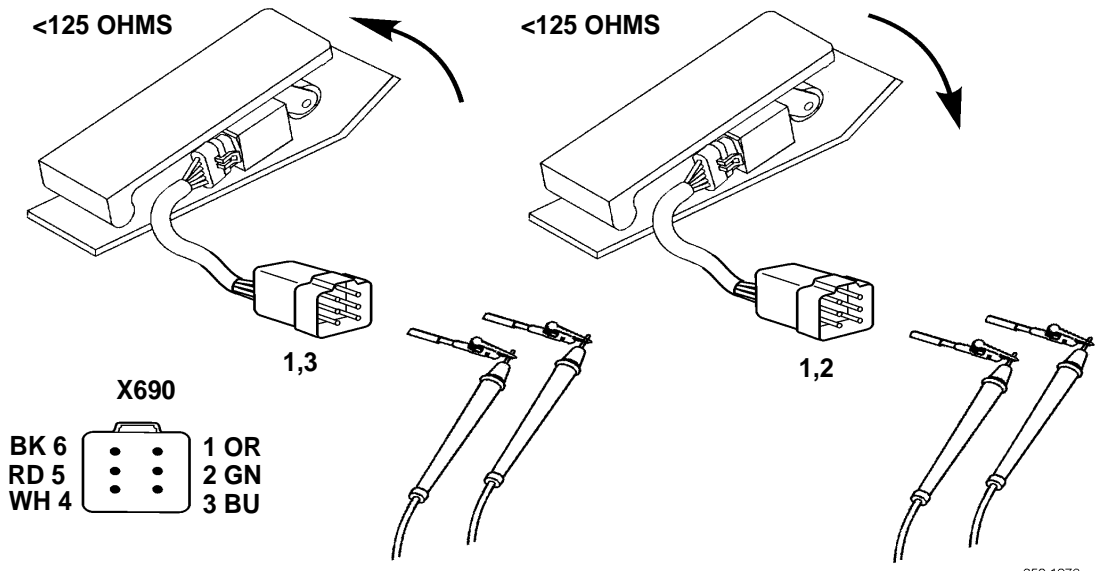
MALFUNCTION	TEST OR INSPECTION	CORRECTIVE ACTION
<p>Error Code 1431 - Voltage Detected at Both Idle Validation Signal Circuits - Continued.</p>  <p><125 OHMS</p> <p><125 OHMS</p> <p>X690</p> <p>BK 6 1 OR RD 5 2 GN WH 4 3 BU</p> <p>USE TEST LEAD KIT P/N 3822917</p> <p>350-1276</p>	<p>7. Check for resistance. Disconnect connector X690 and inspect for damage. Check resistance on the accelerator pedal part of connector X690 between pins 1 and 3. Resistance should be <125 Ohms with the pedal released. Check resistance between pins 1 and 2. Resistance should be <125 Ohms with the pedal depressed (WP 0048 00-11).</p>	<p>a. If resistance is not as specified, replace accelerator pedal assembly (WP 0062 00). b. If resistance is as specified, check continuity and for continuity between wires for wires 233, 234, and 235 (WP 0292 00-11). c. Repair or replace damaged connector (WP 0113 00). d. Replace damaged, open, shorted, or grounded X690 to X23 wiring harness (WP 0113 00).</p>

Table 3. Error Code 1431 - Voltage Detected at Both Idle Validation Signal Circuits Troubleshooting Procedures - Continued.

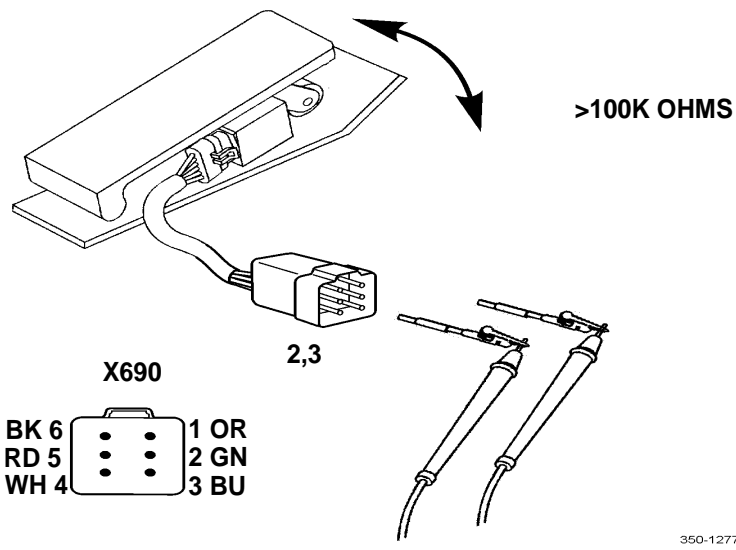
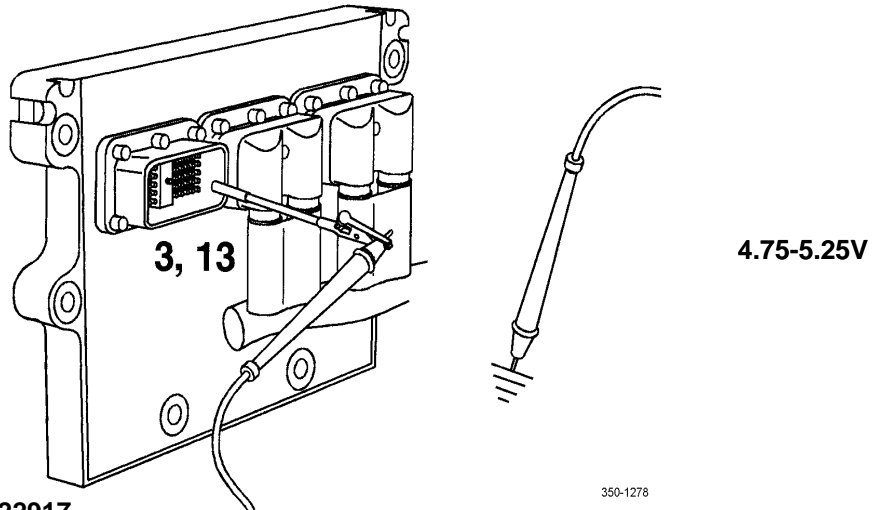
MALFUNCTION	TEST OR INSPECTION	CORRECTIVE ACTION
<p>Error Code 1431 - Voltage Detected at Both Idle Validation Signal Circuits - Continued.</p>	<p>8. Check resistance on the accelerator pedal part of connector X690 between pins 2 and 3 while depressing and releasing the pedal. There should be continuity (WP 0048 00-11).</p>  <p style="text-align: right;">>100K OHMS</p> <p style="text-align: center;">X690</p> <p style="text-align: center;">2,3</p> <p style="text-align: center;">BK 6 1 OR RD 5 2 GN WH 4 3 BU</p> <p>USE TEST LEAD KIT P/N 3822917</p> <p style="text-align: right; font-size: small;">350-1277</p>	<p>a. If voltage (4.75V to 5.25V) is not as specified, continue with step 9.</p> <p>b. Repair or replace damaged connector (WP 0113 00).</p>

Table 3. Error Code 1431 - Voltage Detected at Both Idle Validation Signal Circuits Troubleshooting Procedures - Continued.

MALFUNCTION	TEST OR INSPECTION	CORRECTIVE ACTION
<p>Error Code 1431 - Voltage Detected at Both Idle Validation Signal Circuits - Continued.</p>	<p>9. Inspect connector X16 for damage. Reconnect connector X23 and disconnect connector X16. Turn the ignition on and check for voltage at connector X16 between pin 3 and ground and pin 13 and ground (WP 0048 00-11). There should be 4.75V to 5.25V at each pin.</p>	<p>a. Clean and repair connector as required (WP 0113 00). b. Replace damaged ECU (794) (WP 0080 00).</p>



USE TEST LEAD KIT P/N 3822917

10. Inspect the OEM harness connector and ECU pins for damage, dirt or corrosion. Remove engine cover (WP 0148 00). Disconnect the OEM harness connector from ECU (794) (WP 0080 00).

Table 3. Error Code 1431 - Voltage Detected at Both Idle Validation Signal Circuits Troubleshooting Procedures - Continued.

MALFUNCTION	TEST OR INSPECTION	CORRECTIVE ACTION
<p>Error Code 1431 - Voltage Detected at Both Idle Validation Signal Circuits - Continued.</p>	<p>11. Check for continuity. Disconnect connector X16 and the OEM harness connector. Check continuity of wires 166, 167, and 168 (WP 0048 00-11).</p> <p>12. Check for continuity. Disconnect connector X16 and inspect for damage. Check continuity and for continuity to ground for wires A166, A167, and A168 (WP 0048 00-11).</p> <p>13. Check for continuity. Disconnect the OEM harness connector and connector X16. Check for continuity on the OEM harness connector between pin 3 and all of the other pins in the connector. Check continuity between pin 13 and all of the other pins in the connector. There should not be continuity between pins.</p>	<p>a. If continuity at any one wire is not found, replace engine and transmission wiring harness (WP 0113 00).</p> <p>b. Perform voltage check in step 9 again.</p> <p>c. Replace ECU (794) (WP 0080 00) if step 9 voltage check fails.</p> <p>a. Repair or replace damaged connector (WP 0113 00).</p> <p>b. Replace any damaged, open, or grounded wires.</p> <p>If there is continuity between pin 3 or pin 13 and any other pin in the OEM harness connector, replace the engine and transmission wiring harness (WP 0113 00).</p>

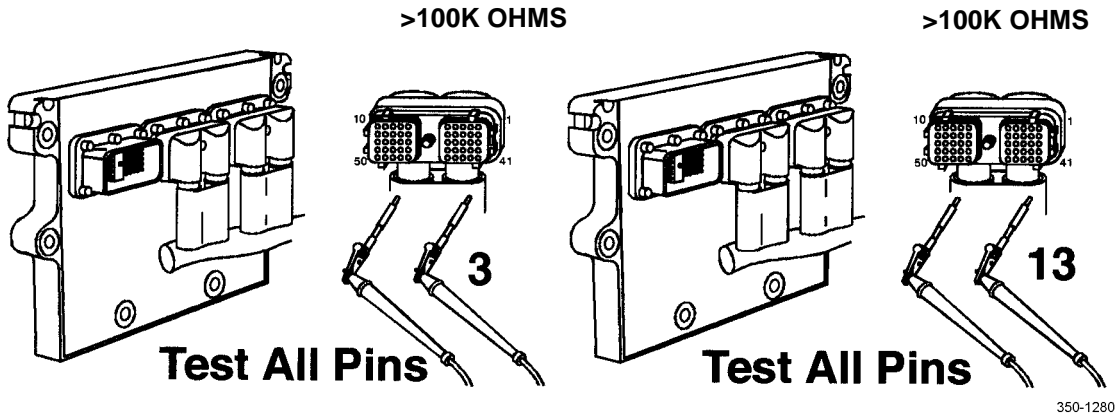


Table 4. Error Code 1432 - Wrong Voltage Signals Detected at Throttle Position Sensor and Idle Validation Circuits Troubleshooting Procedures.


MALFUNCTION	TEST OR INSPECTION	CORRECTIVE ACTION
<p data-bbox="159 434 719 527">Error Code 1432 - Wrong Voltage Signals Detected at Throttle Position Sensor and Idle Validation Circuits.</p> 	<p data-bbox="1045 434 1146 464" style="text-align: center;">NOTE</p> <ul style="list-style-type: none"> <li data-bbox="781 485 1414 541">• Use test lead, female - part number 3823994 (Item 122, WP 0289 00-17) to test connector X690. <li data-bbox="781 558 1414 646">• Use test lead, male - part number 3822758 (Item 124, WP 0289 00-17) to test the OEM harness connector. <ol style="list-style-type: none"> <li data-bbox="735 663 1089 821">1. Check calibration. Turn the ignition on and depress and release the accelerator pedal three times to calibrate the pedal. <li data-bbox="735 835 1089 957">2. Inspect the accelerator pedal assembly for damage and wiring harness connection (WP 0062 00). <li data-bbox="735 972 1089 1129">3. Check connector. Access the cab distribution box in the panel behind the operator's seat. Pull the box out and disconnect connector X23. <li data-bbox="735 1144 1089 1455">4. Check resistance on the loose part of connector X23 between pins 3 and 4. Resistance should be 1,500 to 3,000 Ohms with the pedal released and 250 to 1,500 Ohms with the pedal depressed (WP 0048 00-11). The difference in the two resistance values must be at least 1,000 Ohms. <li data-bbox="735 1470 1089 1654">5. Check connector. Remove the kick panel from in front of the steering column to access the X690 connector on the accelerator pedal wiring harness. 	<p data-bbox="1105 663 1458 751">If ERROR CODE remains active, continue with the troubleshooting procedure.</p> <p data-bbox="1105 835 1430 924">Replace damaged accelerator pedal or connect disconnected wiring harness (WP 0062 00).</p> <p data-bbox="1105 1144 1463 1266">a. If resistance is not as specified, continue with step 5. b. Repair or replace damaged connector (WP 0113 00).</p> <p data-bbox="1105 1470 1430 1591">Check connector X690 for damage. Repair or replace damaged connector (WP 0113 00).</p>

Table 4. Error Code 1432 - Wrong Voltage Signals Detected at Throttle Position Sensor and Idle Validation Circuits Troubleshooting Procedures - Continued.

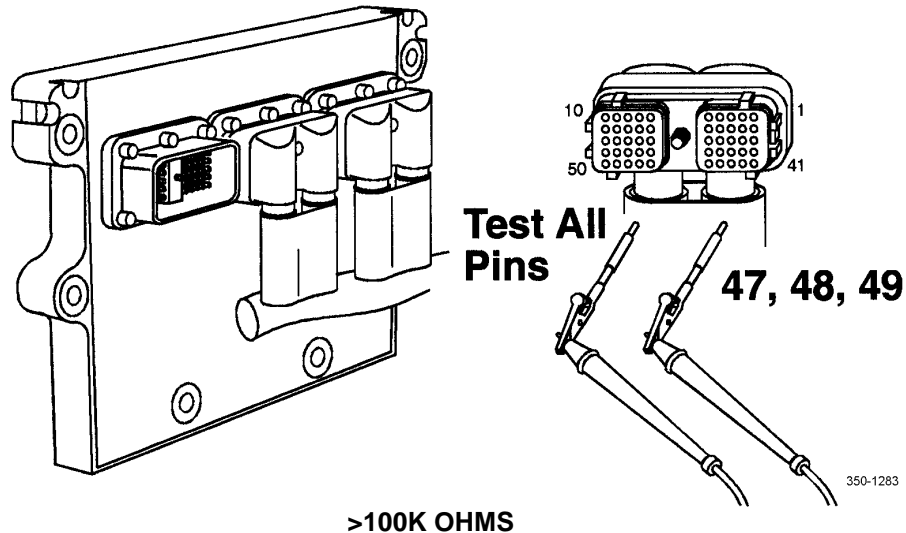
MALFUNCTION	TEST OR INSPECTION	CORRECTIVE ACTION
<p>Error Code 1432 - Wrong Voltage Signals Detected at Throttle Position Sensor and Idle Validation Circuits - Continued.</p>	<p>6. Check resistance on the accelerator pedal part of connector X690 between pins 5 and 6. Resistance should be 1,500 to 3,000 Ohms with the pedal released and 250 to 1,500 Ohms with the pedal depressed (WP 0048 00-11). The difference in the two resistance values must be least 1,000 Ohms.</p>	<p>a. If resistance is not as specified, replace accelerator pedal assembly (WP 0062 00). b. Repair or replace damaged connector (WP 0113 00).</p>
<div style="display: flex; justify-content: space-between; align-items: center;"> <div data-bbox="186 840 592 871"> <p>USE TEST LEAD KIT P/N 3822917</p> </div> <div data-bbox="527 829 1104 1459"> </div> <div data-bbox="1096 861 1315 1018"> <p>1500-3000 OHMS RELEASED</p> <p>250-1500 OHMS DEPRESSED</p> </div> </div> <p data-bbox="162 1407 844 1470">NOTE: RELEASED VALUE MUST BE AT LEAST 1000 OHMS GREATER THAN DEPRESSED VALUE</p> <p data-bbox="1136 1459 1201 1480">350-1281</p>		
	<p>7. Check continuity of wires 233, 234, and 235 between connector X690 and connector X23 (WP 0048 00-11).</p>	<p>a. Repair or replace damaged connector (WP 0113 00). b. Replace damaged, open, shorted, or grounded X690 to X23 wiring harness (WP 0113 00).</p>

Table 4. Error Code 1432 - Wrong Voltage Signals Detected at Throttle Position Sensor and Idle Validation Circuits Troubleshooting Procedures - Continued.

MALFUNCTION	TEST OR INSPECTION	CORRECTIVE ACTION
<p>Error Code 1432 - Wrong Voltage Signals Detected at Throttle Position Sensor and Idle Validation Circuits - Continued.</p>	<p>8. Inspect the OEM harness connector and ECU pins for damage, dirt or corrosion. Remove the engine cover (WP 0148 00). Disconnect the OEM harness connector from ECU (794) (WP 0080 00).</p> <p>9. Disconnect connector X16 and the OEM harness connector. Check continuity of wires 163, 164, and 165 (WP 0048 00-11).</p> <p>10. Check connector and wires. Disconnect connector X16 and inspect for damage. Check continuity of wires A163, A164, and A165 (WP 0048 00-11).</p>	<p>a. Clean and repair connector as required (WP 0113 00). b. Replace damaged ECU (794) (WP 0080 00).</p> <p>If continuity of any wire is not found, replace engine and transmission wiring harness (WP 0113 00).</p> <p>a. Repair or replace damaged connector (WP 0113 00). b. Replace any damaged, open, or grounded wires.</p>


Table 4. Error Code 1432 - Wrong Voltage Signals Detected at Throttle Position Sensor and Idle Validation Circuits Troubleshooting Procedures - Continued.

MALFUNCTION	TEST OR INSPECTION	CORRECTIVE ACTION
<p>Error Code 1432 - Wrong Voltage Signals Detected at Throttle Position Sensor and Idle Validation Circuits - Continued.</p>	<p>11. Check for continuity. Disconnect the OEM harness connector and connector X16. Check for continuity on the OEM harness connector between pin 47 and all of the other pins in the connector, between pin 48 and all the other pins in the connector and between pin 49 and all of the other pins in the connector. There should not be continuity between pins.</p>	<p>If there is continuity between pin 47, 48, or 49 and any other pin in the OEM harness connector, replace the engine and transmission wiring harness (WP 0113 00).</p>



>100K OHMS

Table 5. Error Code 1551 - No Voltage Detected at Both Idle Validation Signal Circuit Troubleshooting Procedures.

MALFUNCTION	TEST OR INSPECTION	CORRECTIVE ACTION
<p data-bbox="155 422 727 485">Error Code 1551 - No Voltage Detected at Both Idle Validation Signal Circuits.</p> 	<p data-bbox="1045 436 1146 468" style="text-align: center;">NOTE</p> <ul data-bbox="781 485 1416 646" style="list-style-type: none"> • Use test lead, female - part number 3823994 (Item 122, WP 0289 00-17) to test connector X690. • Use test lead, male - part number 3822758 (Item 124, WP 0289 00-17) to test the OEM harness connector. <p data-bbox="732 674 1052 762">Perform the troubleshooting procedure for ERROR CODE 1431.</p>	

END OF WORK PACKAGE

THIS WORK PACKAGE COVERS

Error Code 166 - Cooling Fan Speed, Wiring Circuit Failure

Error Code 426 - Fording Level Switch, Circuit Input Error

Error Code 167 - Cooling Fan Speed, Short Circuit Failure

INITIAL SETUP

References

TM 10-3930-675-10

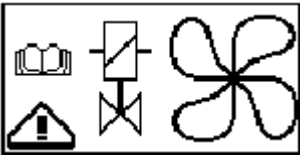
Current Supply (A34738.0200) (WP 0048 00-31)

ECS Electrical Servo (A34648.0200) (WP 0048 00-5)

NOTE

- Refer to WP 0004 00 for additional troubleshooting guidance, information, and illustrations that locate critical components.
- Refer also to illustration at end of work package for component location.

Table 1. Error Code 166 - Cooling Fan Speed, Wiring Circuit Failure Troubleshooting Procedures.

MALFUNCTION	TEST OR INSPECTION	CORRECTIVE ACTION										
<p>Error Code 166 - Cooling Fan Speed, Wiring Circuit Failure.</p>  <table border="1" data-bbox="289 1434 586 1570"> <tr> <td>TEST OR INSPECTION-</td> <td></td> </tr> <tr> <td>DIAG SERVO</td> <td>11(13)</td> </tr> <tr> <td></td> <td>OUTPUT/INPUT</td> </tr> <tr> <td>FAN</td> <td>0mA 0mA</td> </tr> <tr> <td>BL. VALVE</td> <td>0.00V 0mA</td> </tr> </table>	TEST OR INSPECTION-		DIAG SERVO	11(13)		OUTPUT/INPUT	FAN	0mA 0mA	BL. VALVE	0.00V 0mA	<ol style="list-style-type: none"> 1. Enter "DIAG SERVO" 11(13) in the diagnostic menu and observe the FAN "OUTPUT" and "INPUT" should have mA values. 2. Enter "DIAG EXTRA FUNCT." (11(13). Check voltage at X158 between pin 10 and ground while changing the fan speed using the +/- menu selection buttons (WP 0048 00-8). The voltage should vary with fan speed; 10 to 22V. 	<ol style="list-style-type: none"> a. If no "OUTPUT" mA values display, enter into diagnostic menus to check vehicle temperature sensors for proper operation. b. If no "INPUT" mA values display, continue with step 2. <ol style="list-style-type: none"> a. If no voltage (10 to 22V) is found, disconnect X158 and check the resistance on the loose part of X158 between 9 and pin 10. Resistance should be 8 to 10 Ohms. b. If voltage (10 to 22V) is found, disconnect ECU (790) connector 2 and check pin 13 for damage and check continuity of wire A15810 (WP 0048 00-8). c. Repair or replace damaged wires or connectors (WP 0113 00 00).
TEST OR INSPECTION-												
DIAG SERVO	11(13)											
	OUTPUT/INPUT											
FAN	0mA 0mA											
BL. VALVE	0.00V 0mA											

**Table 1. Error Code 166 - Cooling Fan Speed, Wiring
Circuit Failure Troubleshooting Procedures - Continued.**

MALFUNCTION	TEST OR INSPECTION	CORRECTIVE ACTION
<p>Error Code 166 - Cooling Fan Speed, Wiring Circuit Failure - Continued.</p>	<p>3. Remove the rear radiator top grating to access to the cooling fan flow control valve. Unplug the harness and check the resistance of the valve solenoid (6037). Should be 8 to 10 Ohms.</p>	<p>d. Replace damaged ECU (790) (WP 0080 00).</p> <p>a. If resistance (8 to 10 Ohms) is not as specified, replace the cooling fan flow control valve (WP 0263 00).</p> <p>b. If specified resistance is found, check continuity of wires 1589 and 15810 (WP 0048 00-8).</p> <p>c. Replace damaged open or shorted harness (WP 0113 00 00).</p>

Table 2. Error Code 167 - Cooling Fan Speed, Wiring Circuit Failure Troubleshooting Procedures.


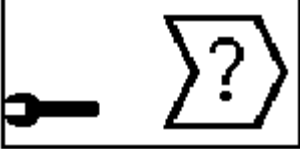
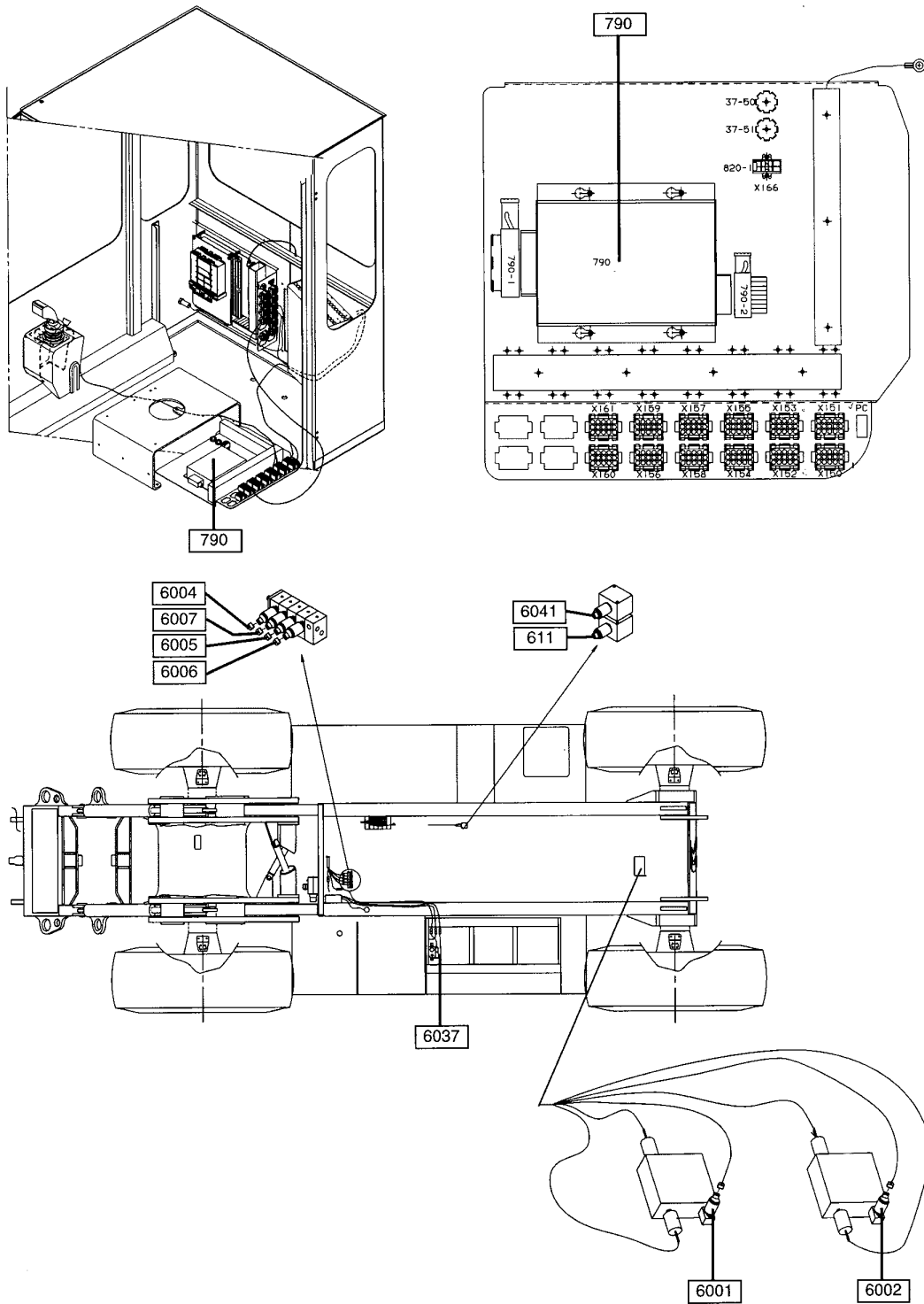
MALFUNCTION	TEST OR INSPECTION	CORRECTIVE ACTION												
<p>Error Code 167 - Cooling Fan Speed, Short Circuit Failure.</p>  <table border="1" data-bbox="289 682 586 814"> <tr> <td>DIAG SERVO</td> <td>11(13)</td> <td></td> </tr> <tr> <td></td> <td>OUTPUT/INPUT</td> <td></td> </tr> <tr> <td>FAN</td> <td>0mA</td> <td>0mA</td> </tr> <tr> <td>BL. VALVE</td> <td>0.00V</td> <td>0mA</td> </tr> </table>	DIAG SERVO	11(13)			OUTPUT/INPUT		FAN	0mA	0mA	BL. VALVE	0.00V	0mA	<ol style="list-style-type: none"> 1. Enter "DIAG SERVO" 11(13) in the diagnostic menu and observe the FAN "OUTPUT" and "INPUT" should have mA values. 2. Enter "DIAG EXTRA FUNCT" 11(13). Check voltage at X158 between pin 10 and ground while changing the fan speed using the +/- menu selection buttons (WP 0048 00-8). The voltage should vary with fan speed; 10 to 22V. 3. Remove the rear radiator top grating to access to the cooling fan flow control valve. Unplug the harness and check the resistance of the valve solenoid (6037). Should be 8 to 10 Ohms. Check solenoid for short to ground. 	<ol style="list-style-type: none"> a. If no "OUTPUT" mA values display, enter into diagnostic menus to check vehicle temperature sensors for proper operation. b. If no "INPUT" mA values display, continue with step 2. a. If no voltage (10 to 22V) is found, disconnect X158 and check the resistance on the loose part of X158 between pin 9 and pin 10. Resistance should be 8 to 10 Ohms. Check continuity of each pin to ground. b. If voltage (10-22V) is found, disconnect ECU (790) connector 2 and check pin 13 for damage and check continuity of wire A15810 and continuity of wire to ground (WP 0048 00-8). c. Repair or replace damaged, shorted wires or connectors (WP 0113 00). d. Replace damaged ECU (790) (WP 0080 00). a. If resistance (8 to 10 Ohms) is not as specified or shorted to ground, replace the cooling fan flow control valve (WP 0263 00). b. If specified resistance is found, check continuity of wires 1589 and 15810 (WP 0048 00-8). c. Replace damaged open or shorted harness (WP 0113 00).
DIAG SERVO	11(13)													
	OUTPUT/INPUT													
FAN	0mA	0mA												
BL. VALVE	0.00V	0mA												

Table 3. Error Code 426 - Fording Level Switch, Circuit Input Error Troubleshooting Procedures.

MALFUNCTION	TEST OR INSPECTION	CORRECTIVE ACTION
<p>Error Code 426 - Fording Level Switch, Circuit Input Error.</p> 	<p style="text-align: center;">NOTE</p> <p>Error code 426 is an information type error code. It may not activate for the operator. Enter DIAG STEERING 2(16) in the diagnostic menu to verify the code or enable the information type codes in the Initialization menu. Input error type codes can be activate if the voltage input is not stable due to a bad connection.</p> <ol style="list-style-type: none"> 1. Inspect the fording level switch for damage and connection. 2. Inspection connectors X195 and X198 (located under the cab and rear cover plate) for connection or damage. 3. Check ECU (792) pin 103 for connection or damage (WP 0048 00-18). 4. Check for wire connection. Disconnect wire A19512 from ECU (792) and recheck for active 426 error code. 	<p style="text-align: center;">NOTE</p> <p>Replace damaged fording level switch (WP 0091 00).</p> <ol style="list-style-type: none"> a. Repair or replace damaged connector (WP 0113 00). b. If connectors are found to be in good condition, check wires BK, GY, and WH (WP 0048 00-29) for continuity. c. Replace or repair open or damaged wire or replace X198 to X195 cable, electrical general maintenance (WP 0113 00). a. Check wire A19512 for continuity (WP 0048 00-18). b. Replace damaged ECU (792) terminal board (WP 0080 00). <p>Replace ECU (792) (WP 0080 00) if error code 426 is still ACTIVE. Replace fording level switch (WP 0091 00).</p>



END OF WORK PACKAGE

OVERLOAD PROTECTION TROUBLESHOOTING

0011 00

THIS WORK PACKAGE COVERS

Error Code 130 - Overload Protection System Failure
 Error Code 131 - Boom Extension Sensor or Circuit Failure
 Error Code 132 - Boom Angle Sensor or Circuit Failure
 Error Code 133 - Left Lift Cylinder Pressure Sensor or Circuit Failure

Error Code 134 - Right Lift Cylinder Pressure Sensor or Circuit Failure
 Error Code 135 - Left Lift Cylinder Piston Pressure Sensor or Circuit Failure
 Error Code 136 - Right Lift Cylinder Piston Pressure Sensor or Circuit Failure
 Error Code 210 - Tophandler Angle Sensor or Circuit Failure

INITIAL SETUP

References

- TM 10-3930-675-10
- Current Supply (A34738.0200) (WP 0048 00-31)
- ECS Attachment (A34652.0200) (WP 0048 00-23)
- ECS Electrical Servo (A34648.0200) (WP 0048 00-5)

NOTE

- Refer to WP 0004 00 for additional troubleshooting guidance, information, and illustrations that locate critical components.
- Refer also to illustrations at end of work package for component location.

Table 1. Error Code 130 - Overload Protection System Failure Troubleshooting Procedures.


MALFUNCTION	TEST OR INSPECTION	CORRECTIVE ACTION
<p>Error Code 130 - Overload Protection System Failure.</p> 	<p>Overload protection system is not working due to an earlier failure (error codes 131 to 136) on any component related to the overload protection system. Hydraulic speeds are limited and the error code will flash on the display every 5 seconds.</p>	<p>Troubleshoot original error codes 131 to 136.</p>

Table 2. Error Code 131 - Boom Extension Sensor or Circuit Failure Troubleshooting Procedures.


MALFUNCTION	TEST OR INSPECTION	CORRECTIVE ACTION										
<p>Error Code 131 - Boom Extension Sensor or Circuit Failure.</p>  <table border="1" data-bbox="293 682 597 810"> <tr> <td>DIAG SERVO</td> <td>1(13)</td> </tr> <tr> <td>SYSTEM POWER</td> <td>24.00V</td> </tr> <tr> <td>POWER RI CAN</td> <td>24.00V</td> </tr> <tr> <td>POWER LE CAN</td> <td>24.00V</td> </tr> <tr> <td>10V REF OUT</td> <td>10.00V</td> </tr> </table>	DIAG SERVO	1(13)	SYSTEM POWER	24.00V	POWER RI CAN	24.00V	POWER LE CAN	24.00V	10V REF OUT	10.00V	<ol style="list-style-type: none"> 1. Look inside the small inspection hole at the rear of the boom and check if the extension steel cable is attached and the harness is connected. 2. Check boom wear plates and for sticking boom extension or retraction while operating. (A sticking boom, especially in the fully lowered position, will active ERROR CODE 131.) 3. Enter "DIAG SERVO 7(13) in the diagnostic menu and check length sensor voltage. The voltage should be around <1 to 4V retracted to extended. 4. Inspect ECU (790) connector 1 pins 13, 26, and 27 and connector for damage. 	<ol style="list-style-type: none"> a. Remove rear boom cover and reattach steel cable to boom extension, inspect sensor and harness for damage (WP 0100 00). b. Reconnect disconnected harness (WP 0100 00). c. Replace damaged boom extension sensor (WP 0100 00). a. Clean boom wear plate surfaces and replace any worn or damaged wear plates (WP 0146 00). b. Check boom system hydraulic pressures (WP 0188 00) and perform hydraulic system troubleshooting (WP 0007 00). a. If no voltage (<1 to 4V) is found, check voltage (10V) at X157 between pins 2 and 3 (WP 0048 00-9). b. If no voltage (10V) is found at X157 between pins 2 and 3, check continuity of wires A15514A, A15514B, A15514C, A15513D, A15513B, A15513A, and A1571 (WP 0048 00-6 and WP 0048 00-9). c. Repair or replace damaged wires or connectors (WP 0113 00). a. Repair or replace damaged wires or connectors (WP 0113 00). b. Replace damaged ECU (790) (WP 0080 00).
DIAG SERVO	1(13)											
SYSTEM POWER	24.00V											
POWER RI CAN	24.00V											
POWER LE CAN	24.00V											
10V REF OUT	10.00V											

Table 2. Error Code 131 - Boom Extension Sensor or Circuit Failure Troubleshooting Procedures - Continued.

MALFUNCTION	TEST OR INSPECTION	CORRECTIVE ACTION
<p>Error Code 131 - Boom Extension Sensor or Circuit Failure - Continued.</p>	<p>5. Check voltage (10V) at X169 between pins 2 and 3 and voltage (<1 to 4V) between pins 1 and 3 with the ignition ON (WP 0048 00-9).</p> <p>6. Remove the rear boom cover to gain access to the boom extension sensor (WP 0100 00). Inspect sensor and harness for damage.</p>	<p>a. If no voltage (10V) is found at X169 between pins 2 and 3, check continuity of wires BK, RD and GY (WP 0048 00-9).</p> <p>b. If no voltage is (<1 to 4V) found, (step 6), replace boom extension sensor (WP 0100 00).</p> <p>c. Replace damaged or open harness (WP 0113 00).</p> <p>a. Disconnect the sensor harness and inspect pins and check continuity of harness wires.</p> <p>b. Inspect the steel cable by pulling it slowly from the sensor and retracting.</p> <p>c. Replace damaged or faulty boom extension sensor (WP 0100 00).</p>

Table 3. Error Code 132 - Boom Angle Sensor or Circuit Failure Troubleshooting Procedures.

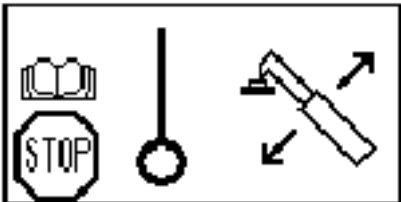
MALFUNCTION	TEST OR INSPECTION	CORRECTIVE ACTION										
<p>Error Code 132 - Boom Angle Sensor or Circuit Failure.</p>  <table border="1" data-bbox="284 682 609 829"> <tr> <td>DIAG SERVO</td> <td>1(13)</td> </tr> <tr> <td>SYSTEM POWER</td> <td>24.00V</td> </tr> <tr> <td>POWER RI CAN</td> <td>24.00V</td> </tr> <tr> <td>POWER LE CAN</td> <td>24.00V</td> </tr> <tr> <td>10V REF OUT</td> <td>10.00V</td> </tr> </table>	DIAG SERVO	1(13)	SYSTEM POWER	24.00V	POWER RI CAN	24.00V	POWER LE CAN	24.00V	10V REF OUT	10.00V	<ol style="list-style-type: none"> 1. Look under the rear of the boom and check the boom angle sensor for damage and proper mounting. 2. Enter "DIAG SERVO 7(13) in the diagnostic menu and check angle sensor voltage. The voltage should be around 8V with the boom fully lowered. 3. Inspect ECU (790) connector 1 pins 16, 26, and 27 and connector for damage. 4. Check voltage (10V) at X169 between pins 2 and 3 and voltage (8V) (boom fully lowered between pins 3 and 4 with the ignition ON (WP 0048 00-9). 	<p>Replace damaged boom angle sensor (WP 0099 00).</p> <ol style="list-style-type: none"> a. If no voltage (8V) is found, check voltage (10V) at X157 between pins 2 and 3 (WP 0048 00-9). b. If no voltage (10V) is found at X157 between pins 2 and 3, check continuity of wires A15514A, A15514B, A15514C, A15513D, A15513C, A15513B, A15513A, and A1571 (WP 0048 00-6 and WP 0048 00-9). c. Repair or replace damaged wires or connectors (WP 0113 00). <ol style="list-style-type: none"> a. Repair or replace damaged wires or connectors (WP 0113 00). b. Replace damaged ECU (790) (WP 0080 00). <ol style="list-style-type: none"> a. If no voltage (10V) is found at X169 between pins 2 and 3, check continuity of wires BK, RD and BU (WP 0048 00-9). b. If no voltage (8V) is found, replace boom angle sensor (WP 0099 00). c. Replace damaged or open harness (WP 0113 00).
DIAG SERVO	1(13)											
SYSTEM POWER	24.00V											
POWER RI CAN	24.00V											
POWER LE CAN	24.00V											
10V REF OUT	10.00V											

Table 4. Error Code 133 - Left Lift Cylinder Pressure Sensor or Circuit Failure Troubleshooting Procedures.

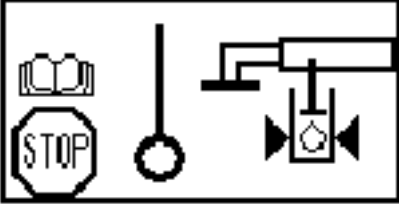
MALFUNCTION	TEST OR INSPECTION	CORRECTIVE ACTION
<p>Error Code 133 - Left Lift Cylinder Pressure Sensor or Circuit Failure.</p>  <pre data-bbox="289 682 592 829"> DIAG SERVO 1(13) SYSTEM POWER 24.00V POWER RI CAN 24.00V POWER LE CAN 24.00V 10V REF OUT 10.00V </pre>	<ol style="list-style-type: none"> 1. Inspect the left lift cylinder locking valve and pressure sensors for damage and connections. 2. Enter "DIAG SERVO" 8(13) in the diagnostic menu and check the pressure sensor voltage. Lift the boom slightly to pressurize the lift cylinders. The voltage should be 3 to 6V depending on boom position. 3. Check voltage (24V) at X159 between pins 3 and 4 with the ignition ON (WP 0048 00-9). 	<ol style="list-style-type: none"> a. Reconnect disconnected sensor harness. b. Replace damaged pressure sensor or harness (WP 0102 00). a. Check PRESS LE "PRESS" and "RETURN" voltages. If the "PRESS" voltage (3 to 6V) is not found and "RETURN" voltage is <2V, switch the pressure sensor harness leads (768-2 and 768-4) (WP 0048 00-9). b. Recheck pressure voltages. If the "RETURN" voltage (<2) appears at "PRESS", replace 768-2 pressure sensor (WP 0102 00). Make sure to switch the sensor leads back after the test. a. If no voltage (24V) is found, check continuity of wires A1543D, A1543C, A15513C, A15513B, A15513A, and 1543B (WP 0048 00-9, WP 0048 00-6, and WP 0048 00-5). b. Repair or replace damaged wires or connectors (WP 0113 00).

Table 4. Error Code 133 - Left Lift Cylinder Pressure Sensor or Circuit Failure Troubleshooting Procedures - Continued.

MALFUNCTION	TEST OR INSPECTION	CORRECTIVE ACTION
<p>Error Code 133 - Left Lift Cylinder Pressure Sensor or Circuit Failure - Continued.</p>	<p>4. Make sure the boom is slightly raised. Check voltage (3 to 6V) at X159 between pins 6 and 4 with the ignition ON (WP 0048 00-9).</p> <p>5. Disconnect sensor harness 768-2 and check voltage (24V) between 1 and 3 with the ignition ON (WP 0048 00-9).</p> <p>6. Remove the engine cover to gain access to X167. Check voltage (24V) at X167 between pins 16 and 17 and check voltage (3 to 6V) between pins 17 and 19 with the ignition ON (WP 0048 00-9).</p>	<p>a. If voltage (3 to 6V) is found, continue with step 5.</p> <p>b. If voltage (3 to 6V) is found, disconnect ECU (790) connector 1 and check pin 17 and connector for damage and check continuity of wire A1596 (WP 0048 00-9).</p> <p>c. Repair or replace damaged wires or connectors (WP 0113 00).</p> <p>d. Replace damaged ECU (790) (WP 0080 00).</p> <p>a. If no voltage (24V) is found, continue with step 6.</p> <p>b. If voltage (24V) is found, check sensor pins and harness for damage, seal and tight fit.</p> <p>c. Replace damaged sensor and harness (WP 0102 00).</p> <p>a. If no voltage (24V) is found at X167 between pins 16 and 17, check continuity of wires RD, BU, and GN (WP 0048 00-9).</p> <p>b. If no voltage (3 to 6V) is found at X167 between pins 17 and 19, check continuity of 768-2 sensor harness (WP 0048 00-9).</p> <p>c. Replace damaged sensor and harness (WP 0102 00).</p> <p>d. Repair or replace damaged wires or connectors (WP 0113 00).</p> <p>e. Replace damaged or open harness (WP 0113 00).</p>

Table 5. Error Code 134 - Right Lift Cylinder Pressure Sensor or Circuit Failure Troubleshooting Procedures.

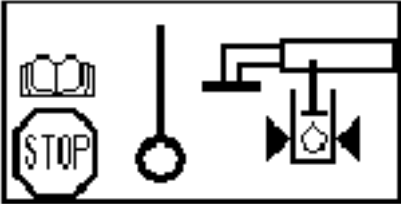
MALFUNCTION	TEST OR INSPECTION	CORRECTIVE ACTION										
<p>Error Code 134 - Right Lift Cylinder Pressure Sensor or Circuit Failure.</p>  <table border="1" data-bbox="284 699 599 877"> <tr> <td>DIAG SERVO</td> <td>1(13)</td> </tr> <tr> <td>SYSTEM POWER</td> <td>24.00V</td> </tr> <tr> <td>POWER RI CAN</td> <td>24.00V</td> </tr> <tr> <td>POWER LE CAN</td> <td>24.00V</td> </tr> <tr> <td>10V REF OUT</td> <td>10.00V</td> </tr> </table>	DIAG SERVO	1(13)	SYSTEM POWER	24.00V	POWER RI CAN	24.00V	POWER LE CAN	24.00V	10V REF OUT	10.00V	<ol style="list-style-type: none"> 1. Inspect the right lift cylinder locking valve and pressure sensors for damage and connections. 2. Enter "DIAG SERVO" 8(13) in the diagnostic menu and check the pressure sensor voltage. Lift the boom slightly to pressurize the lift cylinders. The voltage should be 3 to 6V depending on boom position. 3. Check voltage (24V) at X159 between pins 3 and 4 with the ignition ON (WP 0048 00-9). 4. Make sure the boom is slightly raised. Check voltage (3 to 6V) at X159 between pins 5 and 4 with the ignition ON (WP 0048 00-9). 	<ol style="list-style-type: none"> a. Reconnect disconnected sensor harness. b. Replace damaged pressure sensor or harness (WP 0102 00). a. Check PRESS RI "PRESS" and "RETURN" voltages. If the "PRESS" voltage (3-6V) is not found and "RETURN" voltage is <2V, switch the pressure sensor harness leads (768-1 and 768-3) (WP 0048 00-9). b. Recheck pressure voltages. If the "RETURN" voltage (<2) appears at "PRESS", replace 768-1 pressure sensor (WP 0102 00). Make sure to switch the sensor leads back after the test. a. If no voltage (24V) is found, check continuity of wires A1543D, A1543C, A15513C, A15513B, A15513A, and 1543B (WP 0048 00-9, WP 0048 00-6, and WP 0048 00-5). b. Repair or replace damaged wires or connectors (WP 0113 00). a. If no voltage (3 to 6V) is found, continue with step 5. b. If voltage (3 to 6V) is found, disconnect ECU (790) connector 1 and check pin 18 and connector for damage and check continuity of wire A1595 (WP 0048 00-9). c. Repair or replace damaged wires or connectors (WP 0113 00). d. Replace damaged ECU (790) (WP 0080 00).
DIAG SERVO	1(13)											
SYSTEM POWER	24.00V											
POWER RI CAN	24.00V											
POWER LE CAN	24.00V											
10V REF OUT	10.00V											

Table 5. Error Code 134 - Right Lift Cylinder Pressure Sensor or Circuit Failure Troubleshooting Procedures - Continued.

MALFUNCTION	TEST OR INSPECTION	CORRECTIVE ACTION
<p>Error Code 134 - Right Lift Cylinder Pressure Sensor or Circuit Failure - Continued.</p>	<p>5. Disconnect sensor harness 768-1 and check voltage (24V) between 1 and 3 with the ignition ON (WP 0048 00-9).</p> <p>6. Remove the engine cover to gain access to X167. Check voltage (24V) at X167 between pins 16 and 17 and check voltage (3 to 6V) between pins 17 and 18 with the ignition ON (WP 0048 00-9).</p>	<p>a. If no voltage (24V) is found, continue with step 6.</p> <p>b. If voltage (24V) is found, check sensor pins and harness for damage, seal, and tight fit.</p> <p>c. Replace damaged sensor and harness (WP 0102 00).</p> <p>a. If no voltage (24V) is found at X167 between pins 16 and 17, check continuity of wires RD, BU, and YE (WP 0048 00-9).</p> <p>b. If no voltage (3 to 6V) is found at X167 between pins 17 and 18, check continuity of 768-1 sensor harness (WP 0048 00-9).</p> <p>c. Replace damaged sensor and harness (WP 0102 00).</p> <p>d. Repair or replace damaged wires or connectors (WP 0113 00).</p> <p>e. Replace damaged or open harness (WP 0113 00).</p>

Table 6. Error Code 135 - Left Lift Cylinder Piston Pressure Sensor or Circuit Failure Troubleshooting Procedures.

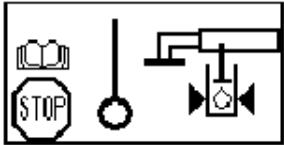
MALFUNCTION	TEST OR INSPECTION	CORRECTIVE ACTION										
<p>Error Code 135 - Left Lift Cylinder Piston Pressure Sensor or Circuit Failure.</p>  <table border="1" data-bbox="282 680 618 827"> <tr> <td>DIAG SERVO</td> <td>1(13)</td> </tr> <tr> <td>SYSTEM POWER</td> <td>24.00V</td> </tr> <tr> <td>POWER RI CAN</td> <td>24.00V</td> </tr> <tr> <td>POWER LE CAN</td> <td>24.00V</td> </tr> <tr> <td>10V REF OUT</td> <td>10.00V</td> </tr> </table>	DIAG SERVO	1(13)	SYSTEM POWER	24.00V	POWER RI CAN	24.00V	POWER LE CAN	24.00V	10V REF OUT	10.00V	<ol style="list-style-type: none"> 1. Inspect the left lift cylinder locking valve and pressure sensors for damage and connections. 2. Enter "DIAG SERVO" 8(13) in the diagnostic menu and check the pressure sensor voltage. Lift the boom slightly to pressurize the lift cylinders. The voltage should be normally <2V at all boom positions. 3. Check voltage (24V) at X159 between pins 3 and 4 with the ignition ON (WP 0048 00-9). 4. Make sure the boom is slightly raised. Check voltage (<2V) at X159 between pins 7 and 4 with the ignition ON (WP 0048 00-9). 	<ol style="list-style-type: none"> a. Reconnect disconnected sensor harness. b. Replace damaged pressure sensor or harness (WP 0102 00). a. Check PRESS RI "PRESS" and "RETURN" voltages. If the "RETURN" voltage (<2V) is not found and "PRESS" voltage is 3 to 6V, switch the pressure sensor harness leads (768-2 and 768-4) (WP 0048 00-9). b. Recheck pressure voltages. IF the "PRESS" voltage (3 to 6V) appears at "RETURN", replace 768-4 pressure sensor (WP 0102 00). Make sure to switch the sensor leads back after the test. a. If no voltage (24V) is found, check continuity of wires A1543D, A1543C, A15513C, A15513B, A15513A, and 1543B (WP 0048 00-9, WP 0048 00-6, and WP 0048 00-5). b. Repair or replace damaged wires or connectors (WP 0113 00). a. If no voltage (<2V) is found, continue with step 5. b. If voltage (<2V) is found, disconnect ECU (790) connector 1 and check pin 19 and connector for damage and check continuity of wire A1597 (WP 0048 00-9). c. Repair or replace damaged wires or connectors (WP 0113 00). d. Replace damaged ECU (790) (WP 0080 00).
DIAG SERVO	1(13)											
SYSTEM POWER	24.00V											
POWER RI CAN	24.00V											
POWER LE CAN	24.00V											
10V REF OUT	10.00V											

Table 6. Error Code 135 - Left Lift Cylinder Piston Pressure Sensor or Circuit Failure Troubleshooting Procedures - Continued.

MALFUNCTION	TEST OR INSPECTION	CORRECTIVE ACTION
<p>Error Code 135 - Left Lift Cylinder Piston Pressure Sensor or Circuit Failure - Continued</p>	<p>5. Disconnect sensor harness 768-4 and check voltage (24V) between 1 and 3 with the ignition ON (WP 0048 00-9).</p> <p>6. Remove the engine cover to gain access to X167. Check voltage (24V) at X167 between pins 16 and 17 and check voltage (<2V) between pins 17 and 21 with the ignition ON (WP 0048 00-9).</p>	<p>a. If no voltage (24V) is found, continue with step 6.</p> <p>b. If voltage (24V) is found, check sensor pins and harness for damage, seal, and tight fit.</p> <p>c. Replace damaged sensor and harness (WP 0102 00).</p> <p>a. If no voltage (24V) is found at X167 between pins 16 and 17, check continuity of wires RD, BU, and BN (WP 0048 00-9).</p> <p>b. If no voltage (2V) is found at X167 between pins 17 and 21, check continuity of 768-4 sensor harness (WP 0048 00-9).</p> <p>c. Replace damaged sensor and harness (WP 0102 00).</p> <p>d. Repair or replace damaged wires or connectors (WP 0113 00).</p> <p>e. Replace damaged or open harness (WP 0113 00).</p>

Table 7. Error Code 136 - Right Lift Cylinder Piston Pressure Sensor or Circuit Failure Troubleshooting Procedures.

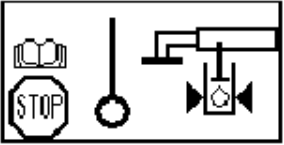
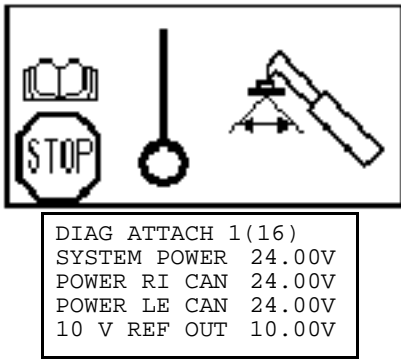
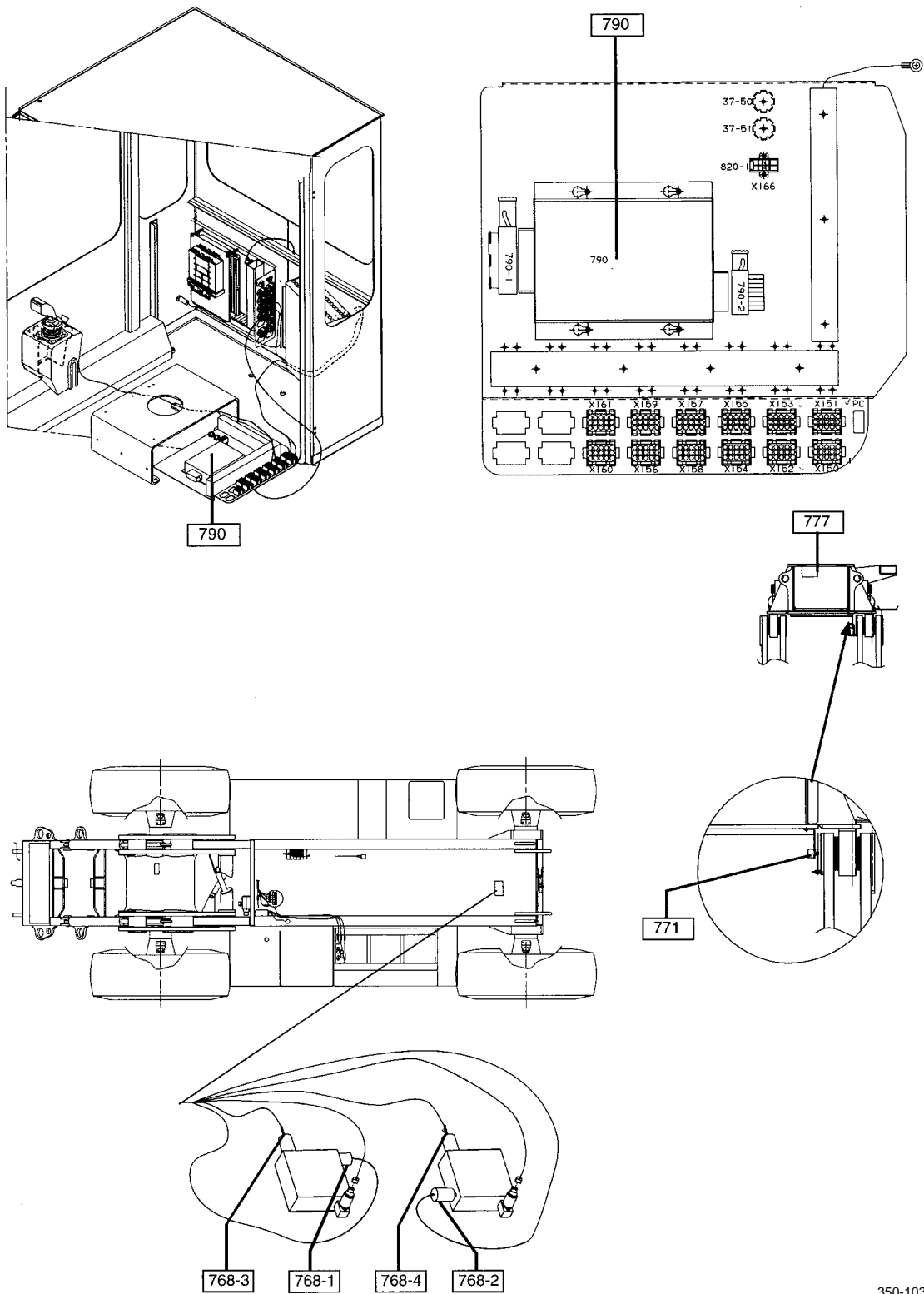
MALFUNCTION	TEST OR INSPECTION	CORRECTIVE ACTION										
<p>Error Code 136 - Right Lift Cylinder Piston Pressure Sensor or Circuit Failure.</p>  <table border="1" data-bbox="272 678 597 831"> <tr> <td>DIAG SERVO</td> <td>1(13)</td> </tr> <tr> <td>SYSTEM POWER</td> <td>24.00V</td> </tr> <tr> <td>POWER RI CAN</td> <td>24.00V</td> </tr> <tr> <td>POWER LE CAN</td> <td>24.00V</td> </tr> <tr> <td>10V REF OUT</td> <td>10.00V</td> </tr> </table>	DIAG SERVO	1(13)	SYSTEM POWER	24.00V	POWER RI CAN	24.00V	POWER LE CAN	24.00V	10V REF OUT	10.00V	<ol style="list-style-type: none"> 1. Inspect the right lift cylinder locking valve and pressure sensors for damage and connections. 2. Enter "DIAG SERVO" 8(13) in the diagnostic menu and check the pressure sensor voltage. Lift the boom slightly to pressurize the lift cylinders. The voltage should normally be <2V at all boom positions. 3. Check voltage (24V) at X159 between pins 3 and 4 with the ignition. 4. Make sure the boom is slightly raised. Check voltage (<2V) at X159 between pins 8 and 4 with the ignition ON (WP 0048 00-9). 	<ol style="list-style-type: none"> a. Reconnect disconnected sensor harness. b. Replace damaged pressure sensor or harness (WP 0102 00). a. Check PRESS RI "PRESS" and "RETURN" voltages. If the "RETURN" voltage (<2V) is not found and "PRESS" voltage is 3 to 6V, switch the pressure sensor harness leads (768-1 and 768 3) (WP 0048 00-9). b. Recheck pressure voltages. If the "PRESS" voltage (3 to 6V) appears at "RETURN", replace 768-3 pressure sensor (WP 0102 00). Make sure to switch the sensor leads back after the test. a. If no voltage (24V) is found, check continuity of wires A1543D, A1543C, A15513C, A15513B, A15513A, and 1543B (WP 0048 00-9, WP 0048 00-6, and WP 0048 00-5). b. Repair or replace damaged wires or connectors (WP 0113 00). a. If no voltage (<2V) is found, continue with step 5. b. If voltage (<2V) is found, disconnect ECU (790) connector 1 and check pin 20 and connector for damage and check continuity of wire A1598 (WP 0048 00-9). c. Repair or replace damaged wires or connectors (WP 0113 00). d. Replace damaged ECU (790) (WP 0080 00).
DIAG SERVO	1(13)											
SYSTEM POWER	24.00V											
POWER RI CAN	24.00V											
POWER LE CAN	24.00V											
10V REF OUT	10.00V											

Table 7. Error Code 136 - Right Lift Cylinder Piston Pressure Sensor or Circuit Failure Troubleshooting Procedures - Continued.

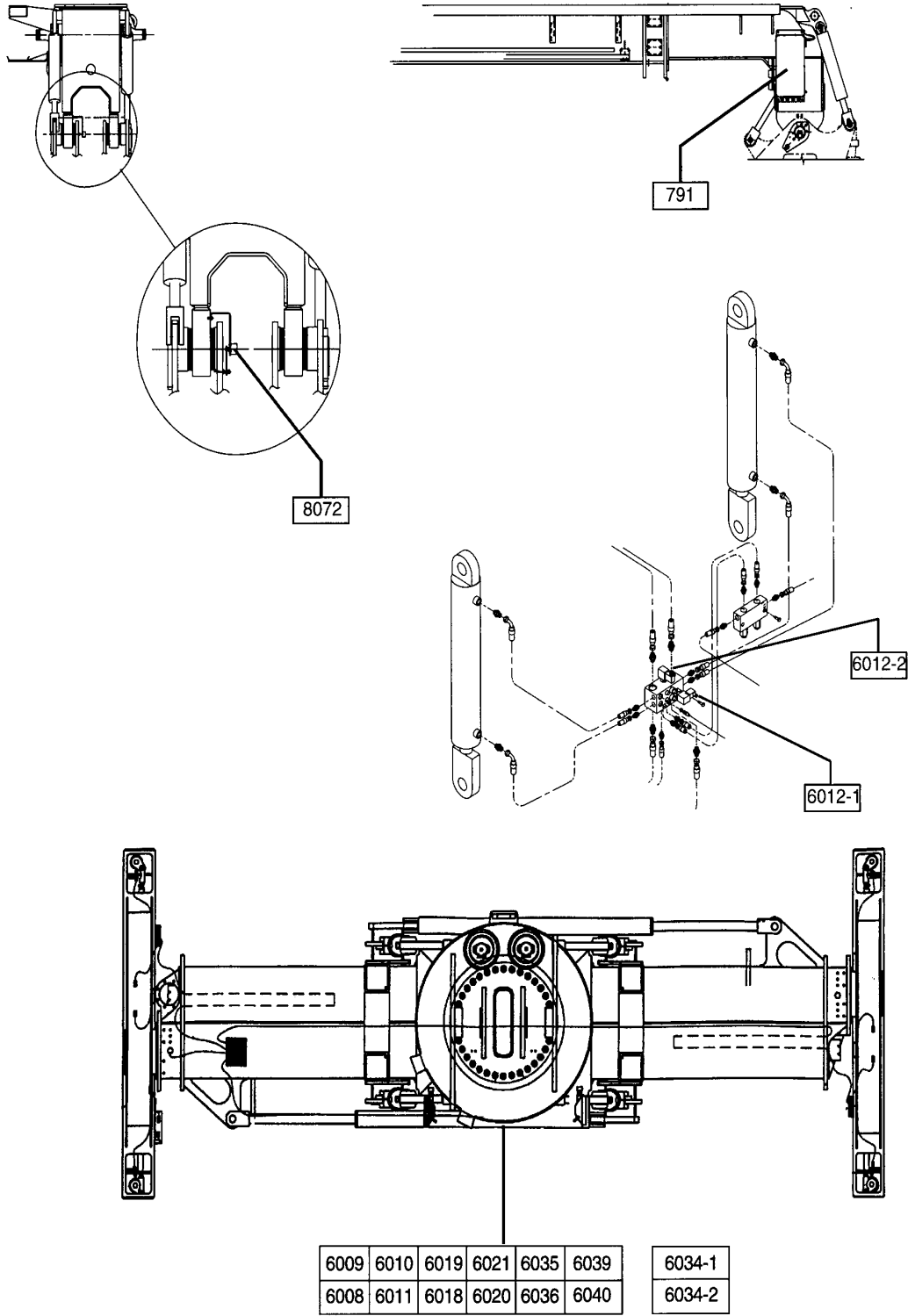
MALFUNCTION	TEST OR INSPECTION	CORRECTIVE ACTION
<p>Error Code 136 - - Right Lift Cylinder Piston Pressure Sensor or Circuit Failure - Continued</p>	<p>5. Disconnect sensor harness 768-3 and check voltage (24V) between 1 and 3 with the ignition ON (WP 0048 00-9).</p> <p>6. Remove the engine cover to gain access to X167. Check voltage (24V) at X167 between pins 16 and 17 and check voltage (<2V) between pins 17 and 20 with the ignition ON (WP 0048 00-9).</p>	<p>a. If no voltage (24V) is found, continue with step 6.</p> <p>b. If voltage (24V) is found, check sensor pins and harness for damage, seal, and tight fit.</p> <p>c. Replace damaged sensor and harness (WP 0102 00).</p> <p>a. If no voltage (24V) is found at X167 between pins 16 and 17, check continuity of wires RD, BU, and WH (WP 0048 00-9).</p> <p>b. If no voltage (24V) is found at X167 between pins 17 and 20, check continuity of 768-3 sensor harness (WP 0048 00-9).</p> <p>c. Replace damaged sensor and harness (WP 0102 00).</p> <p>d. Repair or replace damaged wires or connectors (WP 0113 00).</p> <p>e. Replace damaged or open harness (WP 0113 00).</p>

Table 8. Error Code 210 - Tophandler Angle Sensor or Circuit Failure Troubleshooting Procedures.

MALFUNCTION	TEST OR INSPECTION	CORRECTIVE ACTION
<p>Error Code 210 - Tophandler Angle Sensor or Circuit Failure.</p> 	<ol style="list-style-type: none"> 1. Inspect tophandler angle sensor and lever and bracket for damage and secure mounting. 2. Enter "DIAG ATTACHMENT" 2(16) in the diagnostic menu. Check tilt angle voltage. With boom fully lowered and tophandler level, voltage should be 4 to 6V. 3. Remove the cover from the tophandler junction box to gain access. Check tilt angle sensor cable connections at X180 pins 10, 11, and 12 (WP 0048 00-26). 4. Check voltage (10V) at X180 between pins 10 and 12 (WP 0048 00-26) with the ignition ON. 5. Check voltage at X180 between pins 10 and 11 (WP 0048 00-26) with the ignition ON. Voltage should be 0.3 to 9.5V, depending on tophandler tilt. 	<p>Tighten loose mounting bracket, replace damaged angle sensor or mounting bracket (WP 0100 00).</p> <p>Check lever "clocking" on angle sensor (WP 0259 00).</p> <p>Repair damaged wires or connectors (WP 0113 00)</p> <ol style="list-style-type: none"> a. If no voltage (10V) is found, check continuity of wires A18010, A1801, and A1802 (WP 0048 00-26). b. Repair or replace damaged wires or connectors (WP 0113 00). c. Replace ECU (791) (WP 0080 00). a. If voltage is not as specified, replace tilt angle sensor (WP 0100 00). b. If voltage is as specified, disconnect ECU (791) connector 1 and inspect ECU and connector pins 9, 26, and 27 for damage. c. Replace ECU (791) WP 0080 00.



350-1039



THE VALVES OF THE HYDRAULICS

350-1037

END OF WORK PACKAGE

THIS WORK PACKAGE COVERS

Error Code 205 - Memory Failure

Error Code 220 - Internal Communication Failure, Connector 2

Error Code 221 - Internal Communication Failure, Connector 2

Error Code 250 - Internal Communication Failure, Connector 3

Error Code 251 - Internal Communication Failure, Connector 3

INITIAL SETUP

References

TM 10-3930-675-10

Current Supply (A34738.0200) (WP 0048 00-31)

ECS Attachment (A34652.0200) (WP 0048 00-23)

NOTE

- Refer to WP 0004 00 for additional troubleshooting guidance, information, and illustrations that locate critical components.
- Refer also to illustration at end of work package for component location.

Table 1. Error Code 205 - Memory Failure Troubleshooting Procedures.

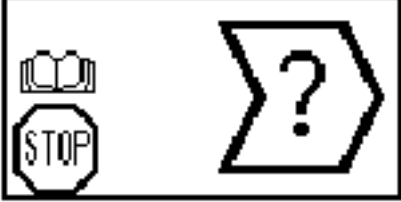
MALFUNCTION	TEST OR INSPECTION	CORRECTIVE ACTION
<p>Error Code 205 - Memory Failure.</p> 	<p>Place ignition switch in OFF position for 30 seconds and then back in ON position.</p>	<p>Replace ECU 791 if error code is still present (WP 0080 00).</p>

Table 2. Error Code 220 - Internal Communication Failure, Connector 2 Troubleshooting Procedures.

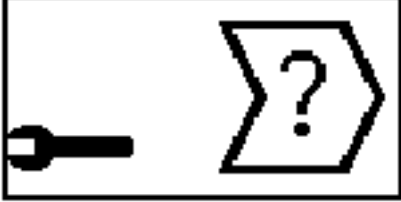
MALFUNCTION	TEST OR INSPECTION	CORRECTIVE ACTION
<p>Error Code 220 - Internal Communication Failure, Connector 2.</p> 	<p>Place ignition switch in OFF position for 30 seconds and then back in ON position.</p>	<p>Replace ECU 791 if error code is still present (WP 0080 00).</p>

Table 3. Error Code 221 - Internal Communications Failure, Connector 2 Troubleshooting Procedures.

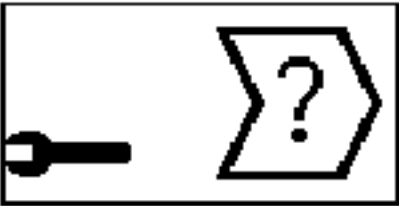
MALFUNCTION	TEST OR INSPECTION	CORRECTIVE ACTION
<p>Error Code 221 - Internal Communication Failure, Connector 2.</p> 	<p>Place ignition switch in OFF position for 30 seconds and then back in ON position.</p>	<p>Replace ECU 791 if error code is still present (WP 0080 00).</p>

Table 4. Error Code 250 - Internal Communication Failure, Connector 3 Troubleshooting Procedures.

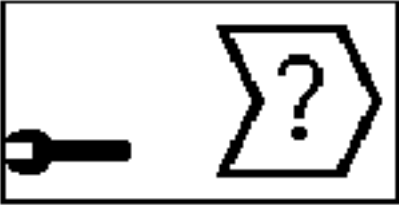
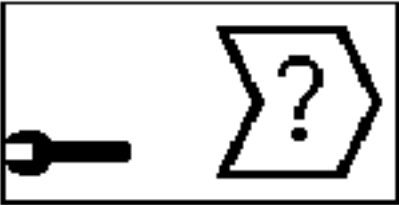
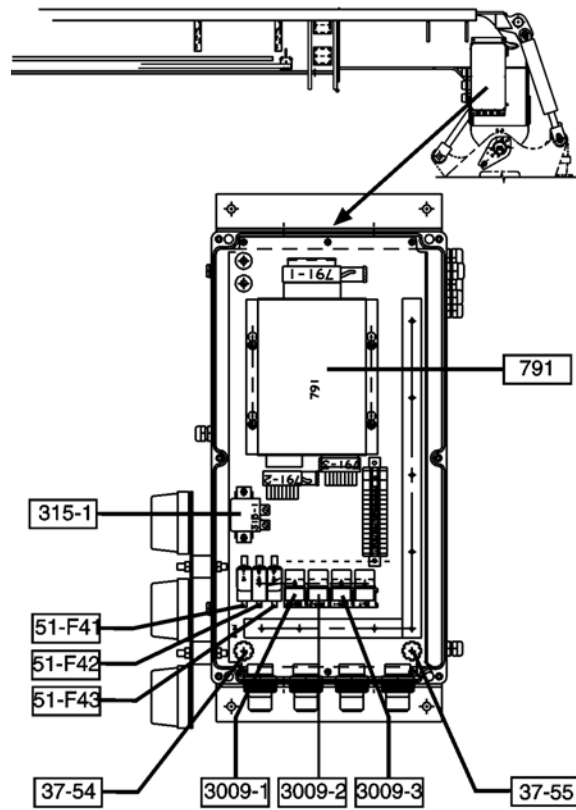
MALFUNCTION	TEST OR INSPECTION	CORRECTIVE ACTION
<p>Error Code 250 - Internal Communication Failure, Connector 3.</p> 	<p>Place ignition switch in OFF position for 30 seconds and then back in ON position.</p>	<p>Replace ECU 791 if error code is still present (WP 0080 00).</p>

Table 5. Error Code 251 - Internal Communication Failure, Connector 3 Troubleshooting Procedures.

MALFUNCTION	TEST OR INSPECTION	CORRECTIVE ACTION
<p>Error Code 251 - Internal Communication Failure, Connector 3.</p> 	<p>Place ignition switch in OFF position for 30 seconds and then back in ON position.</p>	<p>Replace ECU 791 if error code is still present (WP 0080 00).</p>



350-1044

END OF WORK PACKAGE

ELECTRONIC CONTROL UNIT (ECU) INPUT VOLTAGE TROUBLESHOOTING

0013 00

THIS WORK PACKAGE COVERS

Error Code 121 - Supply Voltage to Servo ECU (790) Failure

Error Code 201 - Supply Voltage to Tophandler ECU (791) Failure

Error Code 122 - Supply Voltage to Servo ECU (790) Failure

Error Code 202 - Supply Voltage to Tophandler ECU (791) Failure

Error Code 123 - 10V Reference Voltage for Servo ECU (790) Short Circuit Failure

Error Code 203 - 10V Reference Voltage for Tophandler ECU (791) Failure

INITIAL SETUP

References

TM 10-3930-675-10

Current Supply (A34738.0200) (WP 0048 00-31)

References - Continued

ECS Attachment (A34652.0200) (WP 0048 00-23)

ECS Electrical Servo (A34648.0200) (WP 0048 00-5)

NOTE

- Refer to WP 0004 00 for additional troubleshooting guidance, information, and illustrations that locate critical components.
- Refer also to illustrations at end of work package for component location.

Table 1. Error Code 121 - Supply Voltage to Servo ECU (790) Failure Troubleshooting Procedures.


MALFUNCTION	TEST OR INSPECTION	CORRECTIVE ACTION
<p>Error Code 121 - Supply Voltage to Servo ECU (790) Failure.</p> 	<ol style="list-style-type: none"> 1. Check for emergency stop in engaged position. (Multiple error codes will display if the emergency stop button is engaged during crank and start.) 2. Check voltage (24V) at X154 pins 4 and 1 with the ignition ON (WP 0048 00-5). 	<p>Disengage emergency stop button. (Error codes 121 and 201 will normally be one of the error codes displayed.)</p> <ol style="list-style-type: none"> a. If no voltage (24V) is found at X154 pin 4, gain access to emergency stop switch and check connections and continuity (WP 0082 00) and check continuity of wires 1541 and 1544 (WP 0048 00-5).

Table 1. Error Code 121 - Supply Voltage to Servo ECU (790) Failure Troubleshooting Procedures - Continued.

MALFUNCTION	TEST OR INSPECTION	CORRECTIVE ACTION
<p>Error Code 121 - Supply Voltage to Servo ECU (790) Failure - Continued.</p>	<p>3. Disconnect ECU (790) connector 1 and check voltage (24V) at pins 1 and 15 with the ignition ON (WP 0048 00-5). Inspect ECU (790) connector 1 pins and connector for damage.</p>	<p>b. If no voltage (24V) is found at X154 pin 1, check circuit breaker F30 and continuity of wires A1501 and 301 (WP 0048 00-5) and A301 (WP 0048 00-32).</p> <p>c. Replace damaged or faulty circuit breaker (WP 0074 00).</p> <p>d. Repair or replace damaged wires or connectors (WP 0013 00).</p> <p>e. Replace damaged or faulty emergency stop switch (WP 0082 00).</p> <p>a. If no voltage (24V) is found, check continuity of wires A1544A and A1544B (WP 0048 00-5).</p> <p>b. Repair or replace damaged wires or connectors (WP 0113 00).</p> <p>c. Replace damaged ECU (790) (WP 0080 00).</p>

Table 2. Error Code 122 - Supply Voltage to Servo ECU (790) Failure Troubleshooting Procedures.

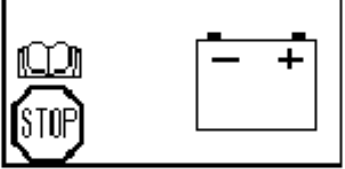
MALFUNCTION	TEST OR INSPECTION	CORRECTIVE ACTION										
<p>Error Code 122 - Supply Voltage to Servo ECU (790) Failure.</p>  <table border="1" data-bbox="267 682 609 829"> <tr> <td>DIAG SERVO</td> <td>1 (13)</td> </tr> <tr> <td>SYSTEM POWER</td> <td>24.00V</td> </tr> <tr> <td>POWER RI CAN</td> <td>24.00V</td> </tr> <tr> <td>POWER LE CAN</td> <td>24.00V</td> </tr> <tr> <td>10V REF OUT</td> <td>10.00V</td> </tr> </table>	DIAG SERVO	1 (13)	SYSTEM POWER	24.00V	POWER RI CAN	24.00V	POWER LE CAN	24.00V	10V REF OUT	10.00V	<ol style="list-style-type: none"> 1. Check circuit breaker F32 for trip. 2. Check voltage (24V) at X150 pin 2 with the ignition ON (WP 0048 00-5). 3. Disconnect ECU (790) connector 1 and check voltage (24V) at pins 7 and 8 with the ignition ON (WP 0048 00-5). Inspect ECU (790) connector 1 pins and connector for damage. 	<p>Reset circuit breaker as required.</p> <ol style="list-style-type: none"> a. If no voltage (24V) is found, check circuit breaker F32 and continuity of wire 302 (WP 0048 00-5) and A304 (WP 0048 00-32). b. Replace damaged or faulty circuit breaker (WP 0074 00). c. Repair or replace damaged wires or connectors (WP 0113 00). <ol style="list-style-type: none"> a. If no voltage (24V) is found, check continuity of wires A1502A and A1502B (WP 0048 00-5). b. Repair or replace damaged wires or connectors (WP 0113 00). c. Replace damaged ECU (790) (WP 0080 00).
DIAG SERVO	1 (13)											
SYSTEM POWER	24.00V											
POWER RI CAN	24.00V											
POWER LE CAN	24.00V											
10V REF OUT	10.00V											

Table 3. Error Code 123 - 10V Reference Voltage for Servo ECU (790) Short Circuit Failure Troubleshooting Procedures.

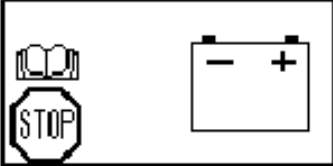
MALFUNCTION	TEST OR INSPECTION	CORRECTIVE ACTION
<p>Error Code 123 - 10V Reference Voltage for Servo ECU (790) Short Circuit Failure.</p>  <pre data-bbox="272 751 602 892"> DIAG SERVO 1(13) SYSTEM POWER 24.00V POWER RI CAN 24.00V POWER LE CAN 24.00V 10V REF OUT 10.00V </pre>	<ol style="list-style-type: none"> 1. Inspect ECU (790) connector <ol style="list-style-type: none"> 1. Check connector, harness, and ECU (790) for damage. 2. Enter "DIAG SERVO" 1(13) in the diagnostic menu. The 10V REF OUT voltage should be around 10V. 3. Reconnect X155 and but leave X157 unplugged. Enter "DIAG SERVO" 1(13) in the diagnostic menu. Check 10V REF OUT voltage. 4. Reconnect X157 and enter "DIAG SERVO" 1(13) in the diagnostic menu. Check 10V REF OUT voltage. 5. Reconnect X169 pin 2 wire BK. Disconnect wire GY from X169 pin 2 (WP 0048 00-9). Enter "DIAG SERVO" 1(13) in the diagnostic menu. Check 10V REF OUT voltage. 	<ol style="list-style-type: none"> a. Repair or replace damaged wires or connectors (WP 0113 00). b. Replace damaged ECU (790) (WP 0080 00). <p>If voltage is <1V, unplug X155 and X157 and recheck 10V REF OUT voltage. If voltage (10V) returns, continue with step 3.</p> <ol style="list-style-type: none"> a. If voltage is <1V, unplug the joystick (WP 0083 00) and recheck 10V REF OUT voltage. If voltage (10V) returns, replace joystick (WP 0082 00). b. If voltage is 10V, continue with step 4. <ol style="list-style-type: none"> a. If voltage is <1V, disconnect the BK wire from X169 pin 2 (WP 0048 00-9) and recheck 10V REF OUT voltage. If voltage (10V) returns, continue with step 5. b. If voltage (10V) does not return, check wire BK for short to ground (WP 0113 00). c. Replace shorted harness (WP 0113 00). <p>If voltage is <1V, disconnect X169 pin 2 wire GN and recheck 10V REF OUT voltage. If voltage (10V) returns, replace boom angle sensor (WP 0099 00).</p>

Table 3. Error Code 123 - 10V Reference Voltage for Servo ECU (790) Short Circuit Failure Troubleshooting Procedures - Continued.

MALFUNCTION	TEST OR INSPECTION	CORRECTIVE ACTION
<p>Error Code 123 - 10V Reference Voltage for Servo ECU (790) Short Circuit Failure - Continued.</p>	<p>6. Reconnect X169 pin 2 wire GY. Disconnect wire GN from X169 pin 2 (WP 0048 00-9). Enter "DIAG SERVO" 1(13) in the diagnostic menu. Check 10V REF OUT voltage.</p>	<p>If voltage is <1V, disconnect X169 pin 2 wire GY again and recheck 10V REF OUT voltage. If voltage (10V) returns, replace boom extension sensor (WP 0100 00).</p>

Table 4. Error Code 201 - Supply Voltage to Tophandler ECU (791) Failure Troubleshooting Procedures.


MALFUNCTION	TEST OR INSPECTION	CORRECTIVE ACTION
<p>Error Code 201 - Supply Voltage to Tophandler ECU (791) Failure.</p>  <pre data-bbox="272 688 591 821"> DIAG ATTACHMENT 1(16) SYSTEM POWER 24.00V POWER RI CAN 24.00V POWER LE CAN 24.00V 10 V REF OUT 10.00V </pre>	<ol style="list-style-type: none"> 1. Check for emergency stop in engaged position. (Multiple error codes will display if the emergency stop button is engaged during crank and start.) 2. Check voltage (24V) at X154 pins 2 and 3 with the ignition ON (WP 0048 00-5). 3. Check voltage (24V) at X155 pin 11 (WP 0048 00-5) and X161 pin 3 (WP 0048 00-6) with the ignition ON. 	<p>Disengage emergency stop button. (Error codes 121 and 201 will normally be one of the error codes displayed.)</p> <ol style="list-style-type: none"> a. If no voltage (24V) is found at X154 pin 3, gain access to emergency stop switch and check connections and continuity (WP 0083 00) and check continuity of wires 1542 and 1543A (WP 0048 00-5). b. If no voltage (24V) is found at X154 pin 1, check circuit breaker F30 and continuity of wires A1504 and 304 (WP 0048 00-5) and A304 (WP 0048 00-32). c. Replace damaged or faulty circuit breaker (WP 0074 00). d. Repair or replace damaged wires or connectors (WP 0113 00). e. Replace damaged or faulty emergency stop switch (WP 0083 00). a. If no voltage (24V) is found at X155 pin 11, check continuity of wire 1542 and 1543A (WP 0048 00-5). b. If no voltage (24V) is found at X161 pin 3, check continuity of wire A1543B (WP 0048 00-6). c. Repair or replace damaged wires or connectors (WP 0113 00).

Table 4. Error Code 201 - Supply Voltage to Tophandler ECU (791) Failure - Continued.

MALFUNCTION	TEST OR INSPECTION	CORRECTIVE ACTION
<p>Error Code 201 - Supply Voltage to Tophandler ECU (791) Failure - Continued.</p>	<p>4. Remove the cover from the tophandler junction box to gain access. Check voltage (24V) at X180 pin 3 (WP 0048 00-23) with the ignition ON.</p> <p>5. Check voltage (24V) between X186 pins 1 and 2 (WP 0048 00-23).</p> <p>6. Remove relay 3009-1 and test (WP 0113 00). Check voltage (24V) and 3009-1 relay socket pins 30 and 86 with the ignition ON (WP 0048 00-23).</p>	<p>a. If no voltage (24V) is found at X180 pin 3, check continuity of wire GY between X180 and X185 (WP 0048 00-23) and wire GY between X185 and X161 and wire A1543C (WP 0048 00-6).</p> <p>b. Repair or replace damaged wires or connectors (WP 0113 00).</p> <p>c. Replace damaged open or shorted harness (WP 0113 00 and WP 0220 00).</p> <p>a. If no voltage (24V) is found, check circuit breaker F40 located under the auxiliary pump (WP 0048 00-33).</p> <p>b. If no voltage (24V) is found, check continuity of wires W28 (WP 0048 00-33) and wire RD between X187 and X186 pin 1 (WP 0048 00-23).</p> <p>c. Replace damaged or faulty circuit breaker (WP 0074 00).</p> <p>d. Repair or replace damaged wires or connectors (WP 0113 00).</p> <p>e. Replace damaged open or shorted harness (WP 0110 00, WP 0111 00, and WP 0220 00).</p> <p>a. Replace damaged or faulty 3009-1 relay (WP 0077 00).</p> <p>b. If no voltage (24V) is found at 3009-1 pin 30, check circuit breaker F41 (1) and continuity of wires A51B, A51J and A1861A (WP 0048 00-23).</p> <p>c. Check operation of relay 315-1 (WP 0048 00-23). Replace damaged or faulty 315-1 relay (WP 0077 00 and WP 0222 00).</p>

Table 4. Error Code 201 - Supply Voltage to Tophandler ECU (791) Failure - Continued.

MALFUNCTION	TEST OR INSPECTION	CORRECTIVE ACTION
<p>Error Code 201 - Supply Voltage to Tophandler ECU (791) Failure - Continued.</p>	<p>7. Disconnect ECU (791) connector 1 and check voltage (24V) at pins 1 and 15 with the ignition ON (WP 0048 00-23). Inspect ECU and connector pins for damage.</p>	<p>d. If no voltage (24V) is found at 3009-1 pin 86, check continuity of wire A1803A (WP 0048 00-23).</p> <p>e. Repair or replace damaged wires or connectors (WP 0113 00).</p> <p>a. If no voltage (24V) is found at ECU (791) connector 1 pins 1 and 15, check operation of relay 3009-2 (WP 0048 00-23). Replace damaged or faulty 3009-2 relay (WP 0077 00).</p> <p>b. If no voltage (24V) is found at ECU (791) connector 1 pins 1 and 15, check continuity of wires A51E, A51F, A51G, and A1803B (WP 0048 00-23).</p> <p>c. Repair or replace damaged wires or connectors (WP 0113 00).</p> <p>d. Replace ECU (791) (WP 0080 00).</p>

Table 5. Error Code 202 - Supply Voltage to Tophandler ECU (791) Failure Troubleshooting Procedures.

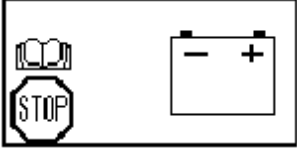
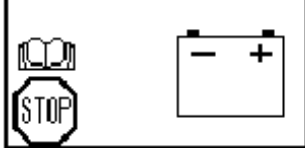
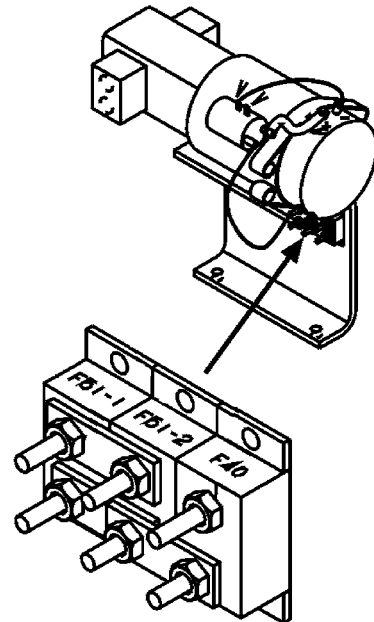
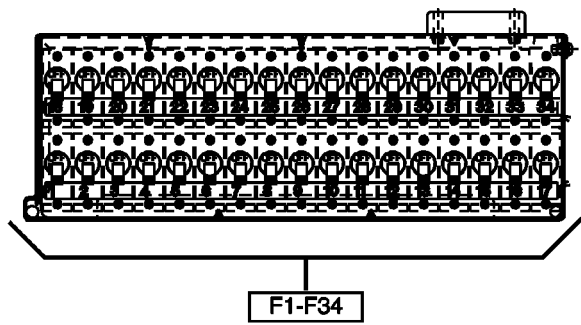
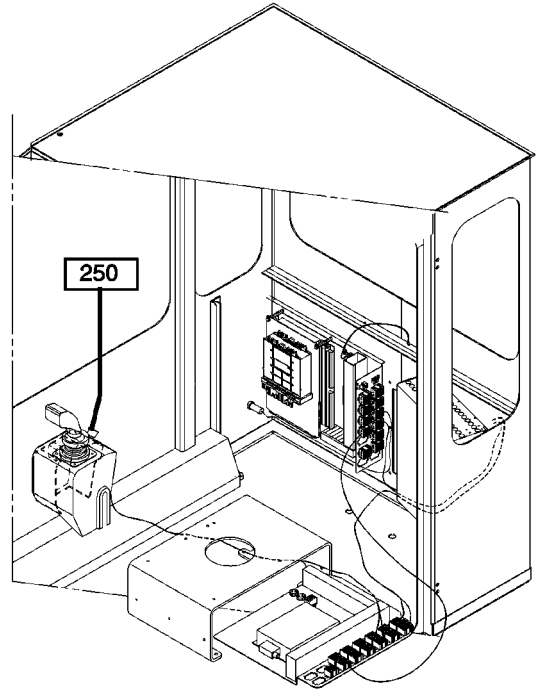
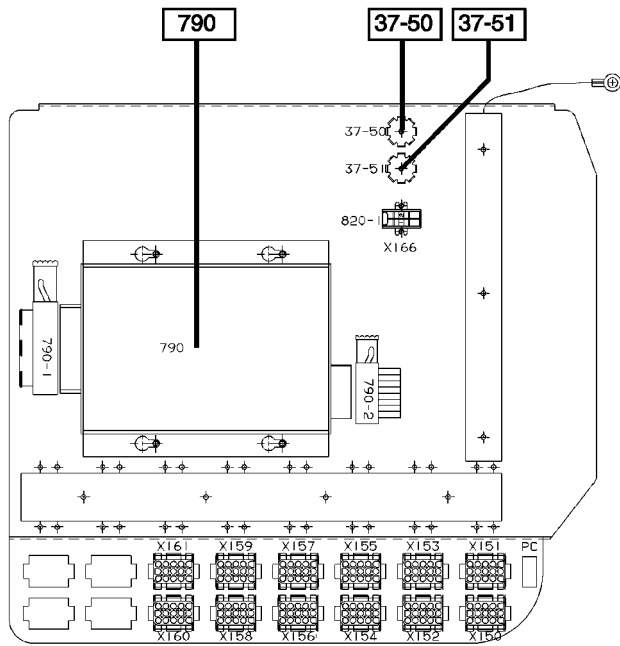
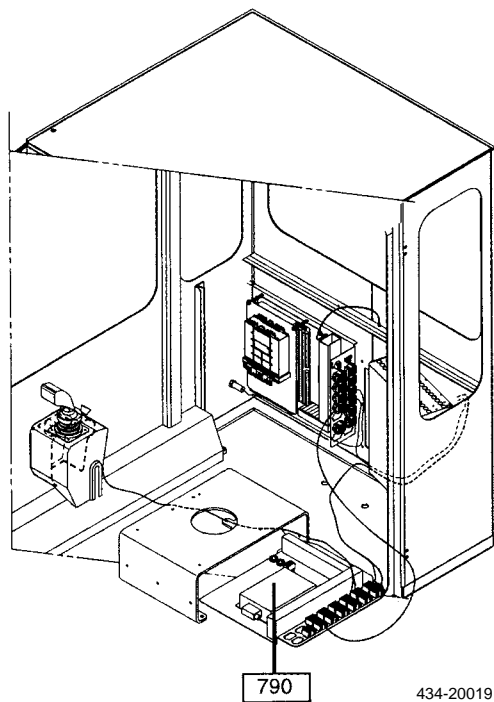
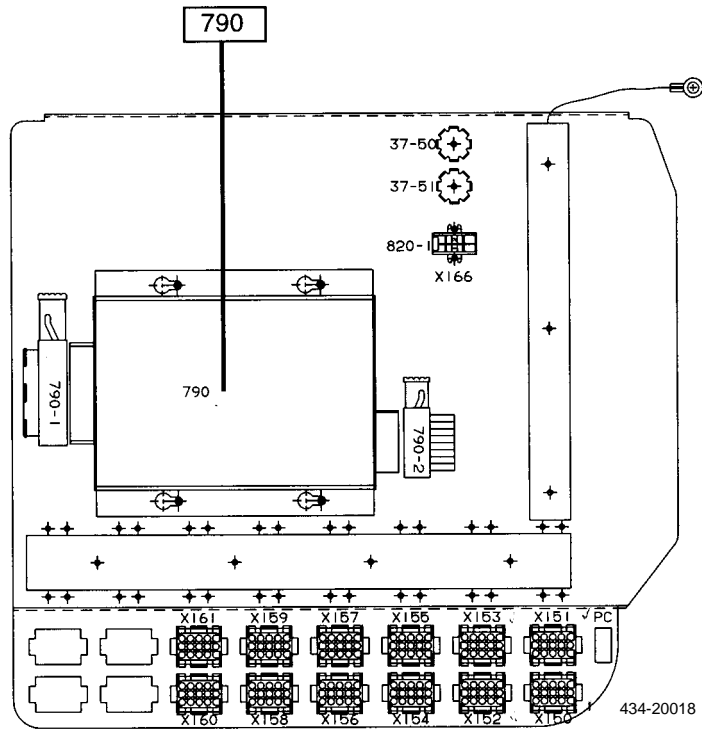
MALFUNCTION	TEST OR INSPECTION	CORRECTIVE ACTION
<p>Error Code 202 - Supply Voltage to Tophandler ECU (791) Failure.</p>  <pre data-bbox="266 680 583 808"> DIAG ATTACHMENT 1(16) SYSTEM POWER 24.00V POWER RI CAN 24.00V POWER LE CAN 24.00V 10 V REF OUT 10.00V </pre>	<ol style="list-style-type: none"> 1. Remove the cover from the tophandler junction box cover to gain access. Check voltage (24V) circuit breaker F41 (1) (WP 0048 00-23) with the ignition ON. 2. Disconnect ECU (791) connector 1 and check voltage (24V) at pins 7 and 8 with the ignition ON (WP 0048 00-23). Inspect ECU and connector pins for damage. 	<ol style="list-style-type: none"> a. If no voltage (24V) is found at F41 (1), check continuity of wire A51J (WP 0048 00-23). b. Replace damaged or faulty circuit breaker (WP 0077 00). c. Repair or replace damaged wires or connectors (WP 0113 00). a. If no voltage (24V) is found at ECU (791) connector 1 pins 7 and 8, check continuity of wires A51A, A51B, and A51C (WP 0048 00-23). b. Repair or replace damaged wires or connectors (WP 0113 00). c. Replace ECU (791) (WP 0080 00).

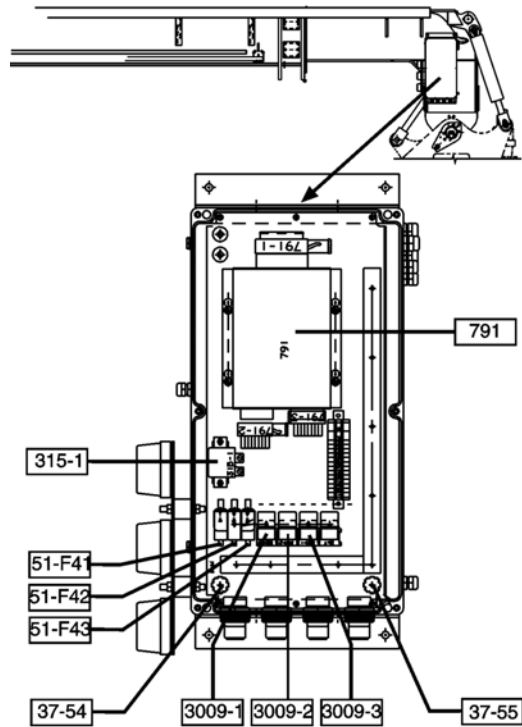
Table 6. Error Code 203 - 10V Reference Voltage for Tophandler ECU (791) Failure Troubleshooting Procedures.

MALFUNCTION	TEST OR INSPECTION	CORRECTIVE ACTION
<p data-bbox="159 411 717 468">Error Code 203 - 10V Reference Voltage for Tophandler ECU (791) Failure.</p> 	<ol style="list-style-type: none"> <li data-bbox="732 411 1089 531">1. Enter "DIAG ATTACHMENT" 1(16) in the diagnostic menu. Check "10V REF OUT" value. <li data-bbox="732 537 1089 688">2. Remove the cover from the tophandler junction box to gain access. Check tilt angle sensor and cable for damage (WP 0048 00-26). <li data-bbox="732 709 1089 829">3. Disconnect the tilt angle sensor from X180 (WP 0048 00-26) and recheck voltage (10V) in the diagnostic menu. <li data-bbox="732 1077 1089 1197">4. Disconnect ECU (791) connector 1 and inspect ECU and connector pins for damage. 	<ol style="list-style-type: none"> <li data-bbox="1105 411 1466 499">a. Should be around 10V. <li data-bbox="1105 506 1466 594">b. If no voltage (10V) is found, proceed with step 2. <p data-bbox="1105 537 1398 594">Replace damaged tilt angle sensor (WP 0101 00).</p> <ol style="list-style-type: none"> <li data-bbox="1105 709 1466 798">a. If voltage (10V) returns, replace tilt angle sensor (WP 0101 00). <li data-bbox="1105 804 1466 955">b. If voltage (10V) does not return, check continuity to ground for wires A18010, A18011, and A18012 (WP 0048 00-26). <li data-bbox="1105 961 1466 1050">c. Repair or replace damaged wires or connectors (WP 0113 00). <li data-bbox="1105 1077 1466 1165">a. Repair or replace damaged wires or connectors (WP 0113 00). <li data-bbox="1105 1171 1466 1228">b. Replace ECU (791) (WP 0080 00).



350-1042





350-1044

END OF WORK PACKAGE

ECU-TO-ECU COMMUNICATIONS TROUBLESHOOTING

0014 00**THIS WORK PACKAGE COVERS**

Error Code 103 - ECU (790) Not Responding (RESET or USMC Only)

Error Code 105 - ECU (790) Not Responding

Error Code 106 - ECU (791) Not Responding

Error Code 107 - Cable Failure Between Tophandler ECU (791) and Display ECU (795)

Error Code 108 - Cable Failure Between Tophandler ECU (791) and Servo ECU (790)

Error Code 109 - Cable Failure Between Servo ECU (790) and Display ECU (795)

Error Code 110 - Communication Failure Between Display ECU (795) and Steering ECU (792)

Error Code 111 - Communication Failure Between Display ECU (795) and Transmission ECU (793)

Error Code 112 - Communication Failure Between Display ECU (795) and Engine ECU (794)

Error Code 345 - Communication Failure Between Steering ECU (792) and Display ECU (795)

Error Code 346 - Communication Failure Between Steering ECU (792) and Transmission ECU (793)

Error Code 684 - Communication Failure Between Transmission ECU (793) and Display ECU (795)

Error Code 685 - Communication Failure Between Transmission ECU (793) and Steering ECU (792)

Error Code 1285 - Engine Detects a Communication Failure on the J1939 Datalink

Error Code 1286 - Engine Detects a Communication Failure on the J1939 Datalink

INITIAL SETUP**Tools and Special Tools**

Test Lead, Female (Item 123, WP 0289 00)

Test Lead, Male (Item 124, WP 0289 00)

References

TM 10-3930-675-10

ECS Display/CAN-BUS (A34647.0200) (WP 0048 00-2)

NOTE

Refer to WP 0004 00 for additional troubleshooting guidance, information, and illustrations that locate critical components.

Table 1. Error Code 103 - ECU 790 Not Responding (RESET or USMC Only).

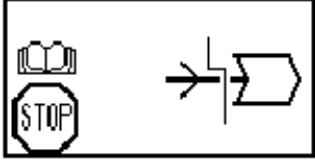
MALFUNCTION	TEST OR INSPECTION	CORRECTIVE ACTION
<p data-bbox="159 409 717 472">Error Code 103 - ECU (790) Not Responding (RESET or USMC Only).</p> 	<ol style="list-style-type: none"> <li data-bbox="734 409 1091 504">1. Check ECU (790) connector 1 for damage or proper connection. <li data-bbox="734 556 1091 703">2. Check for voltage. Disconnect ECU (790) connector 1 and check voltage (24V) at pins 1, 15, 7, and 8 with the ignition ON (WP 0048 00-5). 	<ol style="list-style-type: none"> <li data-bbox="1107 409 1461 472">a. Repair or replace damaged connector (WP 0113 00). <li data-bbox="1107 472 1461 535">b. Reconnect disconnected connector. <li data-bbox="1107 556 1461 682">a. If voltage (24V) is not found at any of the pins, use the wiring diagram to check each circuit (WP 0048 00-5). <li data-bbox="1107 682 1461 766">b. If voltage (24V) is found on all pins, replace ECU (790) (WP 0081 00). <li data-bbox="1107 766 1461 871">c. Repair or replace damaged wires or connectors (WP 0113 00).

Table 2. Error Code 105 - ECU (790) Not Responding Troubleshooting Procedures.

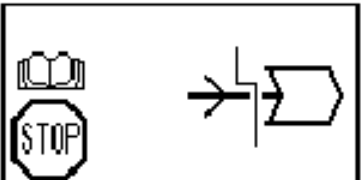
MALFUNCTION	TEST OR INSPECTION	CORRECTIVE ACTION
<p data-bbox="159 1176 717 1207">Error Code 105 - ECU (790) Not Responding.</p> 	<ol style="list-style-type: none"> <li data-bbox="734 1176 1091 1239">1. Check ECU (790) connector 1 damage or proper connection. <li data-bbox="734 1312 1091 1480">2. Disconnect ECU (790) connector 1 and check voltage (24V) at pins 1, 15, 7, and 8 with the ignition ON (WP 0048 00-5). 	<ol style="list-style-type: none"> <li data-bbox="1107 1176 1461 1239">a. Repair or replace damaged connector (WP 0113 00). <li data-bbox="1107 1239 1461 1302">b. Reconnect disconnected connector. <li data-bbox="1107 1323 1461 1449">a. If voltage (24V) is not found at any of the pins, use the wiring diagram to check each circuit (WP 0048 00-5). <li data-bbox="1107 1449 1461 1543">b. If voltage (24V) is found on all pins, replace ECU (790) (WP 0081 00). <li data-bbox="1107 1543 1461 1638">c. Repair or replace damaged wires or connectors (WP 0113 00).

Table 3. Error Code 106 - ECU (791) Not Responding Troubleshooting Procedures.

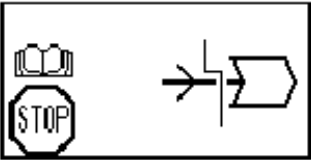
MALFUNCTION	TEST OR INSPECTION	CORRECTIVE ACTION
<p data-bbox="159 409 678 438">Error Code 106 - ECU (791) Not Responding.</p> 	<ol style="list-style-type: none"> <li data-bbox="735 409 1089 499">1. Check voltage (24V) at X161 pin 6 with the ignition ON (WP 0048 00-2). <li data-bbox="735 680 1089 898">2. Remove the cover from the tophandler junction box. Check voltage (24V) between X186 pin 1 and pin 2 and between pin 1 and ground. Check circuit breaker F41 (1) for trip (WP 0048 00-23). <li data-bbox="735 1142 1089 1232">3. Check voltage (24V) at X180 pin 6 with the ignition ON (WP 0048 00-23). <li data-bbox="735 1413 1089 1535">4. Unplug relay 315-1. Check voltage (24V) between the two pins of the connector with the ignition ON (WP 0048 00-23). 	<ol style="list-style-type: none"> <li data-bbox="1107 409 1463 531">a. If no voltage (24V) is found at X161 pin 6, check continuity of wire A1503A (WP 0048 00-2). <li data-bbox="1107 537 1463 627">b. Repair or replace damaged wires or connectors (WP 0113 00). <li data-bbox="1107 680 1463 898">a. If no voltage (24V) is found at X186 pin 1, check circuit breaker F40 located under the auxiliary pump and continuity of cables RD, 1862, W28, and W29 (WP 0048 00-23 and WP 0048 00-33). <li data-bbox="1107 905 1463 961">b. Repair or replace damaged connectors (WP 0113 00). <li data-bbox="1107 968 1463 1024">c. Replace damaged cable (WP 0110 00 and WP 0111 00). <li data-bbox="1107 1031 1463 1121">d. Reset or replace damaged or faulty circuit breaker (WP 0074 00). <li data-bbox="1107 1142 1463 1325">a. If no voltage (24V) is found at X180 pin 6, check continuity of wire YE between X180 and X185 and YE between X185 and X161 pin 6 (WP 0048 00-23). <li data-bbox="1107 1331 1463 1388">b. Replace damaged cable (WP 0220 00). <li data-bbox="1107 1413 1463 1755">a. If no voltage (24V) is found, check continuity of wire A1806 and the ground connection of wire A1806E at 37 - 55. For RESET/USMC check continuity of wires A1806, 194H, and A194J (X194 pins H and J) and ground connection of wire A1806E at 37 - 55 (WP 0048 00-23).

Table 3. Error Code 106 - ECU (791) Not Responding Troubleshooting Procedures - Continued.

MALFUNCTION	TEST OR INSPECTION	CORRECTIVE ACTION
<p>Error Code 106 - ECU (791) Not Responding - Continued.</p>	<p>5. Unplug ECU (791) connector 1. Check voltage (24V) at pins 7 and 8 with the ignition ON (WP 0048 00-23).</p> <p>6. Check voltage (24V) at pins 1 and 15 with the ignition ON (WP 0048 00-23).</p>	<p>b. If voltage (24V) is found, check relay 315-1 (WP 0113 00). c. Repair or replace damaged wires or connectors (WP 0113 00). d. Replace damaged or faulty relay (WP 0074 00 and WP 0222 00).</p> <p>a. If no voltage (24V) is found at ECU (791) connector 1 pins 7 or 8, check circuit breaker F41 (1) (WP 0113 00) and continuity of wires A51A, A51B, and A51C (WP 0048 00-23). b. Repair or replace damaged wires or connectors (WP 0113 00). c. Reset or replace damaged or faulty circuit breaker (WP 0074 00).</p> <p>a. If no voltage (24V) is found at ECU (791) connector 1 pins 1 or 15, check relays 3009-1 and 3009-2 (WP 0113 00) and continuity of wires A51E, A51F, and A51G (WP 0048 00-23). b. Repair or replace damaged wires or connectors (WP 0113 00). c. Replace damaged or faulty relay (WP 0074 00). d. If voltage (24V) is found at all ECU (791) connector 1 pin checks, replace ECU 791 (WP 0080 00).</p>

Table 4. Error Code 107 - Cable Failure Between Tophandler ECU (791) and Display ECU (795) Troubleshooting Procedures.

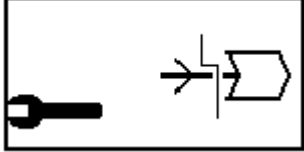
MALFUNCTION	TEST OR INSPECTION	CORRECTIVE ACTION
<p data-bbox="159 443 717 499">Error Code 107 - Cable Failure Between Tophandler ECU (791) and Display ECU (795).</p> 	<ol style="list-style-type: none"> <li data-bbox="732 443 1089 562">1. Inspect the CAN-BUS cable and connector (X185) that is mounted on the right side of the boom for damage. <li data-bbox="732 737 1089 856">2. Check continuity between X152 pin 1 and X161 pin 4, and X152 pin 2 and X161 pin 5 (WP 0048 00-2). <li data-bbox="732 877 1089 997">3. Check continuity between X161 pin 4 and X185 pin 4, and X161 pin 5 and X185 pin 5 (WP 0048 00-2). <li data-bbox="732 1018 1089 1207">4. Remove the cover to the tophandler junction box. Check continuity between X185 pin 4 and X180 pin 4, and X185 pin 5 and X180 pin 5 (WP 0048 00-2). <li data-bbox="732 1228 1089 1381">5. Check continuity between X180 pin 4 and ECU (791) connector 1 pin 2, and X180 pin 5 and ECU (791) connector 1 pin 3 (WP 0048 00). <li data-bbox="732 1402 1089 1619">6. Access display ECU (795) inside driver's control panel (WP 0081 00). Check continuity between (795) pin 11 and X152 pin 1, and between (795) pin 10 and X152 pin 2 (WP 0048 00-2). 	<p data-bbox="1101 443 1414 499">Replace damaged cable (WP 0220 00).</p> <p data-bbox="1101 737 1458 825">If continuity is not present, repair or replace damaged wires or connectors (WP 0113 00).</p> <p data-bbox="1101 877 1458 966">If continuity is not present, replace damaged cable (WP 0113 00).</p> <p data-bbox="1101 1018 1458 1106">If continuity is not present, replace damaged cable (WP 0220 00).</p> <p data-bbox="1101 1228 1458 1316">If continuity is not present, repair or replace damaged wires or connectors (WP 0113 00).</p> <ol style="list-style-type: none"> <li data-bbox="1101 1402 1463 1522">a. If continuity is not present, repair or replace damaged wires or connectors (WP 0113 00). <li data-bbox="1101 1528 1463 1585">b. If continuity is present, replace ECU (790) (WP 0080 00). <li data-bbox="1101 1591 1463 1648">c. Replace ECU (795) (WP 0080 00).

Table 5. Error Code 108 - Cable Failure Between Tophandler ECU (791) and Servo ECU (790) Troubleshooting Procedures.

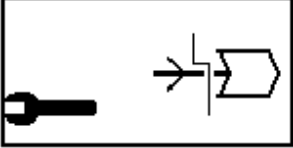
MALFUNCTION	TEST OR INSPECTION	CORRECTIVE ACTION
<p data-bbox="159 443 719 506">Error Code 108 - Cable Failure Between Tophandler ECU (791) and Servo ECU (790).</p> 	<ol style="list-style-type: none"> <li data-bbox="732 443 1088 569">1. Inspect the CAN-BUS cable and connector (X185) that is mounted on the right side of the boom for damage. <li data-bbox="732 583 1088 741">2. Check continuity between X161 pin 1 and ECU (790) connector 1 pin 2, and X161 pin 2 and ECU (790) connector 1 pin 3 (WP 0048 00-2). <li data-bbox="732 756 1088 882">3. Check continuity between X161 pin 1 and X185 pin 1, and X161 pin 2 and X185 pin 2 (WP 0048 00-2). <li data-bbox="732 896 1088 1085">4. Remove the cover to the tophandler junction box. Check continuity between X185 pin 1 and X180 pin 1, and X185 pin 2 and X180 pin 2 (WP 0048 00-2). <li data-bbox="732 1100 1088 1268">5. Check continuity between X180 pin 1 and ECU (791) connector 1 pin 4, X180 pin 2 and ECU (791) connector 1 pin 5 (WP 0048 00-2). 	<p data-bbox="1104 443 1458 506">Replace damaged cable (WP 0220 00).</p> <p data-bbox="1104 583 1458 678">If continuity is not present, repair or replace damaged wires or connectors (WP 0113 00).</p> <p data-bbox="1104 756 1458 850">If continuity is not present, replace damaged cable (WP 0113 00).</p> <p data-bbox="1104 896 1458 991">If continuity is not present, replace damaged cable (WP 0220 00).</p> <ol style="list-style-type: none"> <li data-bbox="1104 1100 1458 1226">a. If continuity is not present, repair or replace damaged wires or connectors (WP 0113 00). <li data-bbox="1104 1232 1458 1295">b. If continuity is present, replace ECU (791) (WP 0080 00). <li data-bbox="1104 1302 1458 1365">c. Replace ECU (790) (WP 0080 00).

Table 6. Error Code 109 - Cable Failure Between Servo ECU (790) and Display ECU (795) Troubleshooting Procedures.

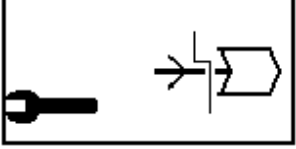
MALFUNCTION	TEST OR INSPECTION	CORRECTIVE ACTION
<p data-bbox="159 443 722 506">Error Code 109 - Cable Failure Between Servo ECU (790) and Display ECU (795).</p> 	<ol style="list-style-type: none"> <li data-bbox="735 443 1089 600">1. Check continuity between X152 pin 4 and ECU (790) connector 1 pin 4, and X152 pin 5 and ECU (790) connector 1 pin 5 (WP 0048 00-2). <li data-bbox="735 726 1089 936">2. Access display ECU (795) inside driver's control panel (WP 0081 00). Check continuity between (795) pin 13 and X152 pin 4, and between (795) pin 12 and X152 pin 5 (WP 0048 00-2). 	<p data-bbox="1105 443 1458 537">If continuity is not present, repair or replace damaged wires or connectors (WP 0113 00).</p> <ol style="list-style-type: none"> <li data-bbox="1105 726 1458 842">a. If continuity is not present, repair or replace damaged wires or connectors (WP 0113 00). <li data-bbox="1105 852 1458 905">b. If continuity is present, replace ECU (790) (WP 0080 00). <li data-bbox="1105 915 1458 968">c. Replace ECU (795) (WP 0080 00).

Table 7. Error Code 110 - Communication Failure Between Display ECU (795) and Steering ECU (792) Troubleshooting Procedures.

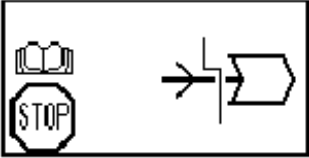
MALFUNCTION	TEST OR INSPECTION	CORRECTIVE ACTION
<p data-bbox="159 443 717 533">Error Code 110 - Communication Failure Between Display ECU (795) and Steering ECU (792).</p> 	<ol style="list-style-type: none"> <li data-bbox="734 443 1088 506">1. Enter "EXTRA FUNC" 9(13) in the diagnostic menu. <li data-bbox="734 600 1088 695">2. Check steering ECU (792) terminal board for loose or damaged connections. <li data-bbox="734 726 1088 821">3. Check ECU (792) pins 159 and 160 for loose connection (WP 0048 00-16). <li data-bbox="734 842 1088 1031">4. Inspect jumpers between terminal connections at X179. Check continuity between (792) pin 159 and X179 pin L, and between (792) pin 160 and X179 pin H (WP 0048 00-3). <li data-bbox="734 1052 1088 1167">5. Check continuity between X179 pin L and X177 pin 8, and between X179 pin H and X177 pin 7 (WP 0048 00-3). <li data-bbox="734 1188 1088 1314">6. Check continuity between X177 pin 8 and X160 pin 8, and between X177 pin 7 and X160 pin 7 (WP 0048 00-3). <li data-bbox="734 1335 1088 1461">7. Check continuity between X160 pin 8 and X152 pin 8, and between X160 pin 7 and X152 pin 7 (WP 0048 00-3). <li data-bbox="734 1482 1088 1692">8. Access display ECU (795) inside driver's control panel (WP 0081 00). Check continuity between (795) pin 6 and X152 pin 7, and between (795) in 5 and X152 pin 8 (WP 0048 00-2). 	<p data-bbox="1107 443 1453 569">Should have a "1" next to "RX 792 STEERING". If there is a "0", continue with step 2.</p> <p data-bbox="1107 600 1453 695">Replace damaged terminal board or tighten connections (WP 0080 00).</p> <p data-bbox="1107 726 1453 758">Tighten loose connections.</p> <ol style="list-style-type: none"> <li data-bbox="1107 842 1453 957">a. If continuity is not present, repair or replace damaged wires or connectors (WP 0113 00). <li data-bbox="1107 968 1453 1031">b. Replace missing or damaged jumpers. <p data-bbox="1107 1052 1453 1146">If continuity is not present, repair or replace damaged wires or connectors (WP 0113 00).</p> <p data-bbox="1107 1188 1453 1283">If continuity is not present, repair or replace damaged wires or connectors (WP 0113 00).</p> <p data-bbox="1107 1335 1453 1430">If continuity is not present, repair or replace damaged wires or connectors (WP 0113 00).</p> <ol style="list-style-type: none"> <li data-bbox="1107 1482 1453 1598">a. If continuity is not present, repair or replace damaged wires or connectors (WP 0113 00). <li data-bbox="1107 1608 1453 1671">b. If continuity is present, replace ECU (792) (WP 0081 00). <li data-bbox="1107 1682 1453 1734">c. Replace ECU (795) (WP 0081 00).

Table 8. Error Code 111 - Communication Failure Between Display ECU (795) and Transmission ECU (793) Troubleshooting Procedures.

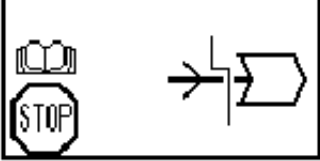
MALFUNCTION	TEST OR INSPECTION	CORRECTIVE ACTION
<p data-bbox="159 443 717 533">Error Code 111 - Communication Failure Between Display ECU (795) and Transmission ECU (793).</p> 	<ol style="list-style-type: none"> <li data-bbox="734 443 1084 506">1. Enter "EXTRA FUNC" 9(13) in the diagnostic menu. <li data-bbox="734 583 1084 674">2. Check transmission ECU (793) for loose or damaged connectors. <li data-bbox="734 695 1084 758">3. Check ECU (793) pins 25 and 26 for loose connectors. <li data-bbox="734 779 1084 968">4. Inspect jumpers between terminal connectors at X179. Check continuity between (793) pin 25 and X179 pin H, and between (793) pin 26 and X179 pin L (WP 0048 00-3). <li data-bbox="734 989 1084 1104">5. Check continuity between X179 pin L and X177 pin 8, and between X179 pin H and X177 pin 7 (WP 0048 00-3). <li data-bbox="734 1125 1084 1241">6. Check continuity between X177 pin 8 and X160 pin 8, and between X177 pin 7 and X160 pin 7 (WP 0048 00-3). <li data-bbox="734 1262 1084 1388">7. Check continuity between X160 pin 8 and X152 pin 8, and between X160 pin 7 and X152 pin 7 (WP 0048 00-3). <li data-bbox="734 1409 1084 1629">8. Access display ECU (795) inside driver's control panel (WP 0081 00). Check continuity between (795) pin 6 and X152 pin 7, and between (795) pin 5 and X152 pin 8 (WP 0048 00-2). 	<p data-bbox="1107 443 1453 558">Should have a "1" next to "RX 793 GEARBOX". If there is a "0", continue with step 2.</p> <p data-bbox="1107 583 1453 646">Replace damaged connector or ECU (793) (WP 0080 00).</p> <p data-bbox="1107 695 1453 758">Repair any loose or missing connectors (WP 0113 00).</p> <p data-bbox="1107 779 1453 968">a. If continuity is not present, repair or replace damaged wires or connectors (WP 0113 00). b. Replace missing or damaged jumpers.</p> <p data-bbox="1107 989 1453 1073">If continuity is not present, repair or replace damaged wires or connectors (WP 0113 00).</p> <p data-bbox="1107 1125 1453 1220">If continuity is not present, repair or replace damaged wires or connectors (WP 0113 00).</p> <p data-bbox="1107 1262 1453 1356">If continuity is not present, repair or replace damaged wires or connectors (WP 0113 00).</p> <p data-bbox="1107 1409 1453 1661">a. If continuity is not present, repair or replace damaged wires or connectors (WP 0113 00). b. If continuity is present, replace ECU (793) (WP 0080 00). c. Replace ECU (795) (WP 0080 00).</p>

Table 9. Error Code 112 - Communication Failure Between Display ECU (795) and Engine ECU (794) Troubleshooting Procedures.

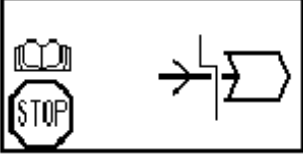
MALFUNCTION	TEST OR INSPECTION	CORRECTIVE ACTION
<p>Error Code 112 - Communication Failure Between Display ECU (795) and Engine ECU (794).</p> 	<ol style="list-style-type: none"> 1. Check circuit breaker F13 for trip. 2. Enter "EXTRA FUNC" 9(13) in the diagnostic menu. 3. Check engine ECU (794) for loose or damaged connectors (WP 0048 00-10). 4. Check ECU (794) OEM connector pins 37, 38, and 46 for dirty, corroded, bent, broken, pushed back, or extended pins (WP 0048 00-10). 5. Locate X202 attached the harness just below the ECU (794) OEM connector (WP 0048 00-3). 	<ol style="list-style-type: none"> a. Reset F13 circuit breaker. Engine will not start if F13 is off. b. If engine will not start, check voltage at F13, X16 pin 9 and ECU (794) OEM connector pin 38 with the ignition switch ON. c. If no voltage present, check continuity of wires A169 and 169 (WP 0048 00-10). d. Replace damaged or faulty circuit breaker (WP 0074 00). <p>Should have a "1" next to "RX 794 ENGINE". If there is a "0", continue with step 3.</p> <p>Replace damaged connector or ECU (794) (WP 0080 00).</p> <p>Clean and repair connector as required (WP 0113 00).</p> <ol style="list-style-type: none"> a. Check X202 plug connector for damage or loose connection. b. Unplug X202 and check resistance on the plugged part of the connector between pin 1 and 4. Resistance should be 122 Ohms. c. Clean and repair connector as required (WP 0113 00). Replace if damaged.

Table 9. Error Code 112 - Communication Failure Between Display ECU (795) and Engine ECU (794) Troubleshooting Procedures - Continued.

MALFUNCTION	TEST OR INSPECTION	CORRECTIVE ACTION
<p>Error Code 112 - Communication Failure Between Display ECU (795) and Engine ECU (794) - Continued.</p>	<p>6. Inspect jumpers between terminal connectors at X179. Check continuity between (794) OEM pin 37 and X179 pin L, and between (794) OEM pin 46 and X179 pin H (WP 0048 00-3 and WP 0048 00-10).</p> <p>7. Check continuity between X179 pin L and X177 pin 8, and between X179 pin H and X177 pin 7 (WP 0048 00-3).</p> <p>8. Check continuity between X177 pin 8 and X160 pin 8, and between X177 pin 7 and X160 pin 7 (WP 0048 00-3).</p> <p>9. Check continuity between X160 pin 8 and X152 pin 8, and between X160 pin 7 and X152 pin 7 (WP 0048 00-3).</p> <p>10. Access display ECU (795) inside driver's control panel (WP 0081 00). Check continuity between (795) pin 6 and X152 pin 7, and between (795) pin 5 and X152 pin 8 (WP 0048 00-2).</p>	<p>a. If continuity is not present, repair or replace damaged wires or connectors (WP 0113 00).</p> <p>b. Replace missing or damaged jumpers.</p> <p>If continuity is not present, repair or replace damaged wires or connectors (WP 0113 00).</p> <p>If continuity is not present, repair or replace damaged wires or connectors (WP 0113 00).</p> <p>If continuity is not present, repair or replace damaged wires or connectors (WP 0113 00).</p> <p>a. If continuity is not present, repair or replace damaged wires or connectors (WP 0113 00).</p> <p>b. If continuity is present, replace ECU (794) (WP 0080 00).</p> <p>c. Replace ECU (795) (WP 0080 00).</p>

Table 10. Error Code 345 - Communication Failure Between Steering ECU (792) and Display ECU (795) Troubleshooting Procedures.

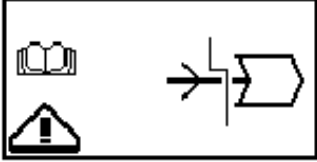
MALFUNCTION	TEST OR INSPECTION	CORRECTIVE ACTION
<p data-bbox="159 443 717 533">Error Code 345 - Communication Failure Between Steering ECU (792) and Display ECU (795).</p> 	<p data-bbox="732 443 1049 499">Perform troubleshooting procedure for error code 110.</p>	

Table 11. Error Code 346 - Communication Failure Between Steering ECU (792) and Transmission ECU (793) Troubleshooting Procedures.

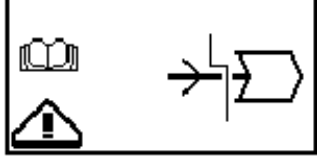
MALFUNCTION	TEST OR INSPECTION	CORRECTIVE ACTION
<p data-bbox="159 947 717 1037">Error Code 346 - Communication Failure Between Steering ECU (792) and Transmission ECU (793).</p> 	<ol data-bbox="732 947 1089 1087" style="list-style-type: none"> 1. Check circuit breakers F27 and F28 for trip. 2. Perform troubleshooting procedure for error code 111. 	<p data-bbox="1105 947 1455 978">Reset circuit breaker as required.</p>

Table 12. Error Code 684 - Communication Failure Between Transmission ECU (793) and Display ECU (795) Troubleshooting Procedures.

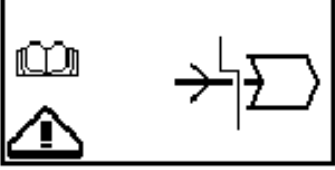
MALFUNCTION	TEST OR INSPECTION	CORRECTIVE ACTION
<p data-bbox="159 441 717 533">Error Code 684 - Communication Failure Between Transmission ECU (793) and Display ECU (795).</p> 	<p data-bbox="732 441 1086 533">1. Perform troubleshooting steps for error code 111 (WP 0113 00).</p> <p data-bbox="1045 737 1146 768" style="text-align: center;">NOTE</p> <p data-bbox="781 785 1414 877" style="text-align: center;">Ensure you disconnect and isolate each connector/circuit mentioned in error code 111 steps before checking for continuity to ground.</p> <p data-bbox="732 894 1086 953">2. Perform each continuity check for continuity to ground.</p>	<p data-bbox="1105 894 1446 953">Replace any wire found to have continuity to ground.</p>

Table 13. Error Code 685 - Communication Failure Between Transmission ECU (793) and Steering ECU (792) Troubleshooting Procedures.

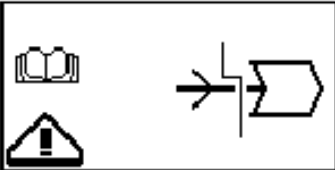
MALFUNCTION	TEST OR INSPECTION	CORRECTIVE ACTION
<p data-bbox="159 1152 717 1245">Error Code 685 - Communication Failure Between Transmission ECU (793) and Steering ECU (792).</p> 	<p data-bbox="732 1152 1086 1245">1. Check steering ECU (792) and transmission ECU (793) for loose or damaged connectors.</p> <p data-bbox="732 1262 1086 1320">2. Check ECU (792) pins 159 and 160 for loose connection.</p> <p data-bbox="732 1337 1086 1556">3. Inspect jumpers between terminal connections at X179. Check continuity and for continuity to ground between (792) pin 159 and X179 pin L, and between (792) pin 160 and X179 pin H.</p> <p data-bbox="732 1572 1086 1724">4. Check continuity and for continuity to ground between X179 pin L and (793) pin 26, and between X179 pin H and (793) pin 25.</p>	<p data-bbox="1105 1152 1459 1245">Replace damaged connector or ECU (792), ECU (793) (WP 0080 00).</p> <p data-bbox="1105 1262 1395 1291">Tighten loose connections.</p> <p data-bbox="1105 1337 1463 1430">a. If continuity is not present, repair any loose or missing connections.</p> <p data-bbox="1105 1434 1463 1493">b. Replace missing or damaged jumpers.</p> <p data-bbox="1105 1497 1433 1526">c. Replace any grounded wire.</p> <p data-bbox="1105 1572 1463 1665">a. If continuity is not present, repair any loose or missing connections.</p> <p data-bbox="1105 1669 1433 1698">b. Replace any grounded wire.</p> <p data-bbox="1105 1703 1463 1761">c. Replace ECU (793) (WP 0080 00).</p> <p data-bbox="1105 1766 1463 1824">d. Replace ECU (792) (WP 0080 00).</p>

Table 14. Error Code 1285 - Engine Detects a Communication Failure on the J1939 Datalink Troubleshooting Procedures.



MALFUNCTION	TEST OR INSPECTION	CORRECTIVE ACTION
<p data-bbox="147 432 724 499">Error Code 1285 - Engine Detects a Communication Failure on the J1939 Datalink.</p> 	<p data-bbox="724 432 1096 499">Perform the troubleshooting procedures for error code 112.</p>	

Table 15. Error Code 1286 - Engine Detects a Communication Failure on the J1939 Datalink Troubleshooting Procedures.

MALFUNCTION	TEST OR INSPECTION	CORRECTIVE ACTION
<p data-bbox="147 894 724 961">Error Code 1286 - Engine Detects a Communication Failure on the J1939 Datalink.</p> 	<p data-bbox="724 894 1096 961">Perform the troubleshooting procedures for error code 112.</p>	

END OF WORK PACKAGE

STEERING ECU (792), TRANSMISSION ECU (793), AND ENGINE ECU (794) TROUBLESHOOTING 0015 00

THIS WORK PACKAGE COVERS

Error Code 300 - Steering ECU (792) Hardware Failure
 Error Code 841 - Transmission ECU (793) Memory Failure
 Error Code 843 - Application Error Failure
 Error Code 1111 - Engine ECU (794) Memory Failure

Error Code 1341 - Engine ECU (794) Loss of Data Failure
 Error Code 1343 - Engine ECU (794) Internal Communication Failure
 Error Code 1346 - Engine ECU (794) Software Failure

INITIAL SETUP

Tools and Special Tools

Test Lead, Male (Item 124, WP 0289 00)

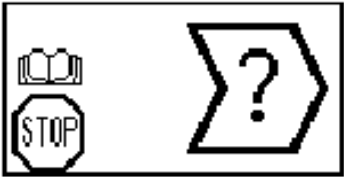
References

TM 10-3930-675-10

NOTE

- Refer to WP 0004 00 for additional troubleshooting guidance, information, and illustrations that locate critical components.
- Refer also to illustration at end of work package for component location.

Table 1. Error Code 300 - Steering ECU (792) Hardware Failure Troubleshooting Procedures.

MALFUNCTION	TEST OR INSPECTION	CORRECTIVE ACTION
<p>Error Code 300 - Steering ECU (792) Hardware Failure.</p> 	<p style="text-align: center;">NOTE</p> <p>If the engine is cranked and not started, then re-cranked without turning the ignition OFF, ERROR CODE 300 may be displayed. Turn off ignition for 30 seconds and restart.</p> <ol style="list-style-type: none"> 1. Check circuit breakers F26 and F29 for trip. 2. Check voltage (24V) at X174 pin 3 (WP 0048 00-16) with the ignition ON. 	<p>Reset circuit breakers as required (WP 0074 00).</p> <ol style="list-style-type: none"> a. If no voltage (24V) is found, check circuit breaker F29 and continuity of wires A473 (WP 0048 00-32) and 473 (WP 0048 00-16). b. Replace damaged or faulty circuit breaker (WP 0074 00). c. Repair or replace damaged wires or connectors (WP 0113 00).

**STEERING ECU (792), TRANSMISSION ECU (793), AND ENGINE ECU (794)
TROUBLESHOOTING - CONTINUED**

0015 00

Table 1. Error Code 300 - Steering ECU (792) Hardware Failure Troubleshooting Procedures - Continued.

MALFUNCTION	TEST OR INSPECTION	CORRECTIVE ACTION
<p>Error Code 300 - Steering ECU (792) Hardware Failure - Continued.</p>	<p>3. If circuit breaker F29 trips during operation, check voltage output circuits from ECU (792) for short circuit, brake cooling, auxiliary pump, twistlock, and steering indicator lights. (For USMC Autolube system.) (ARMY only 7208 and 7210 cab proximity switches, filter indicators.)</p> <p>4. Check voltage (24V) at X174 pin 14 (WP 0048 00-16) with the ignition ON.</p> <p>5. Check voltage (24V) at ECU (792) pin 1 (WP 0048 00-16) with the ignition ON.</p> <p>6. Check voltage (24V) at ECU (792) pin 5 (WP 0048 00-16) with the ignition ON.</p>	<p>Perform appropriate troubleshooting and repairs for short circuit.</p> <p>a. If no voltage (24V) is found, check circuit breaker F26 and continuity of wires A48 (WP 0048 00-32) and 478 (WP 0048 00-16).</p> <p>b. Replace damaged or faulty circuit breaker (WP 0074 00).</p> <p>c. Repair or replace damaged wires or connectors (WP 0113 00).</p> <p>a. If no voltage (24V) is found, check continuity of wire A17414 and jumper wire 7923 (WP 0048 00-16).</p> <p>b. Repair or replace damaged wires or connectors (WP 0113 00).</p> <p>a. If no voltage (24V) is found, check continuity of wire A17414 and jumper wire 7923 (WP 0048 00-16).</p> <p>b. Repair or replace damaged wires or connectors (WP 0113 00).</p> <p>c. Replace ECU (792) (WP 0080 00).</p>

**STEERING ECU (792), TRANSMISSION ECU (793), AND ENGINE ECU (794)
TROUBLESHOOTING - CONTINUED**

0015 00

Table 2. Error Code 841 - Transmission ECU (793) Memory Failure Troubleshooting Procedures.

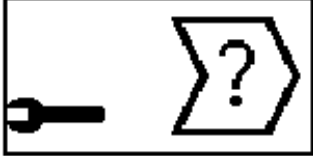
MALFUNCTION	TEST OR INSPECTION	CORRECTIVE ACTION
<p>Error Code 841 - Transmission ECU (793) Memory Failure.</p> 	<p>Place ignition switch in OFF position for 30 seconds and then back in ON position.</p>	<p>Replace transmission ECU (793) if error code is still present (WP 0080 00).</p>

Table 3. Error Code 843 - Application Error Failure Troubleshooting Procedures.

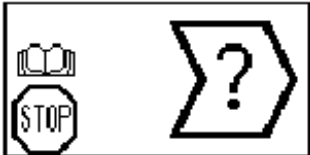
MALFUNCTION	TEST OR INSPECTION	CORRECTIVE ACTION
<p>Error Code 843 - Application Error Failure.</p> 	<p>Place ignition switch in OFF position for 30 seconds and then back in ON position.</p>	<p>Replace transmission ECU (793) if error code is still present (WP 0080 00).</p>

Table 4. Error Code 1111 - Engine ECU (794) Memory Failure Troubleshooting Procedures.

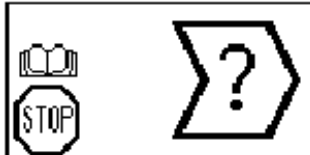
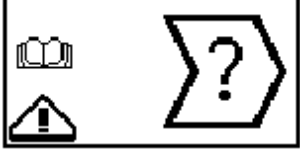
MALFUNCTION	TEST OR INSPECTION	CORRECTIVE ACTION
<p>Error Code 1111 - Engine ECU (794) Memory Failure.</p> 	<p>Turn ignition switch to OFF position for 30 seconds and then back to ON position.</p>	<p>Replace engine ECU (794) if error code still appears (WP 0079 00).</p>

Table 5. Error Code 1341 - Engine ECU (794) Loss of Data Failure Troubleshooting Procedures.

MALFUNCTION	TEST OR INSPECTION	CORRECTIVE ACTION
<p data-bbox="159 443 722 499">Error Code 1341 - Engine ECU (794) Loss of Data Failure.</p> 	<p data-bbox="732 443 1092 600">1. Ensure ignition switch is in OFF position. Disconnect OEM harness from engine ECU (794) and perform the following resistance checks:</p> <p data-bbox="760 653 1092 800">a. Measure resistance from OEM harness connector pin 7 to positive (+) battery terminal. Resistance should be less than 10 Ohms.</p> <p data-bbox="760 831 1092 978">b. Measure resistance from OEM harness connector pin 8 to positive (+) battery terminal. Resistance should be less than 10 Ohms.</p> <p data-bbox="760 1010 1092 1157">c. Measure resistance from OEM harness connector pin 17 to positive (+) battery terminal. Resistance should be less than 10 Ohms.</p> <p data-bbox="760 1188 1092 1335">d. Measure resistance from OEM harness connector pin 18 to positive (+) battery terminal. Resistance should be less than 10 Ohms.</p> <p data-bbox="760 1367 1092 1514">e. Measure resistance from OEM harness connector pin 28 to positive (+) battery terminal. Resistance should be less than 10 Ohms.</p>	<p data-bbox="1102 443 1463 537">a. If resistance is not as specified, repair engine harness connectors (WP 0113 00).</p> <p data-bbox="1102 548 1463 642">b. Notify Sustainment Maintenance to replace engine harness.</p>

STEERING ECU (792), TRANSMISSION ECU (793), AND ENGINE ECU (794)
TROUBLESHOOTING - CONTINUED

0015 00

Table 5. Error Code 1341 - Engine ECU (794) Loss of Data Failure Troubleshooting Procedures - Continued.

MALFUNCTION	TEST OR INSPECTION	CORRECTIVE ACTION
<p>Error Code 1341 - Engine ECU (794) Loss of Data Failure - Continued.</p> <div data-bbox="292 546 1396 1134" style="text-align: center;"> <p>USE TEST LEAD KIT P/N 3822758</p> <p>7, 8, 17, 18, 28</p> <p><math><10\text{ OHMS}</math></p> <p>350-1143</p> </div>		

STEERING ECU (792), TRANSMISSION ECU (793), AND ENGINE ECU (794)
TROUBLESHOOTING - CONTINUED

0015 00

Table 5. Error Code 1341 - Engine ECU (794) Loss of Data Failure Troubleshooting Procedures - Continued.

MALFUNCTION	TEST OR INSPECTION	CORRECTIVE ACTION
<p>Error Code 1341 - Engine ECU (794) Loss of Data Failure - Continued.</p>	<p>2. Turn ignition switch to ON position and check battery voltage by placing positive (+) probe of multimeter on positive (+) battery terminal and touch negative (-) probe to negative (-) battery terminal while trying to start engine. Voltage should be at least (+)12V during normal conditions and at least (+)6V during cranking. Check each battery in the same way.</p>	<p>If voltage is not as required, charge or replace battery (WP 0108 00).</p>
	<p>3. Turn ignition switch to OFF position and check battery terminals for secure connection.</p> <p>4. Check circuit breakers 51-F4 and 51-F5.</p>	<p>Clean terminals and tighten loose battery terminal connections.</p> <p>a. Reset circuit breakers, if tripped. b. If circuit breakers will not reset, notify SRA.</p>

350-1144

Table 6. Error Code 1343 - Engine ECU (794) Internal Communication Failure Troubleshooting Procedures.


MALFUNCTION	TEST OR INSPECTION	CORRECTIVE ACTION
<p data-bbox="159 441 717 499">Error Code 1343 - Engine ECU (794) Internal Communication Failure.</p> 	<ol style="list-style-type: none"> <li data-bbox="730 441 1091 630">1. Ensure ignition switch is in OFF position and check all engine and vehicle power and ground connections for corrosion and loose connections. <li data-bbox="730 646 1091 835">2. With ignition switch in OFF position, disconnect OEM harness from engine ECU (794). Disconnect positive (+) and negative (-) battery cables from battery. <li data-bbox="730 852 1091 911">3. Check engine ECU (794) connectors for moisture. <li data-bbox="730 928 1091 1642">4. Check all power resistances: <ol style="list-style-type: none"> <li data-bbox="760 961 1091 1117">a. Measure resistance from engine harness connector pin 7 to positive (+) battery terminal. Resistance should be less than 10 Ohms. <li data-bbox="760 1134 1091 1289">b. Measure resistance from engine harness connector pin 8 to positive (+) battery terminal. Resistance should be less than 10 Ohms. <li data-bbox="760 1306 1091 1461">c. Measure resistance from engine harness connector pin 17 to positive (+) battery terminal. Resistance should be less than 10 Ohms. <li data-bbox="760 1478 1091 1633">d. Measure resistance from engine harness connector pin 18 to positive (+) battery terminal. Resistance should be less than 10 Ohms. 	<ol style="list-style-type: none"> <li data-bbox="1104 441 1425 470">a. Tighten loose connections. <li data-bbox="1104 474 1461 533">b. Repair or replace damaged connections (WP 0113 00). <p data-bbox="1104 852 1403 882">Dry connectors as required.</p> <ol style="list-style-type: none"> <li data-bbox="1104 928 1461 1029">a. If resistance is not as specified, repair engine harness connectors (WP 0113 00). <li data-bbox="1104 1033 1461 1121">b. Notify Sustainment Maintenance to replace engine harness.

Table 6. Error Code 1343 - Engine ECU (794) Internal
Communication Failure Troubleshooting Procedures - Continued.

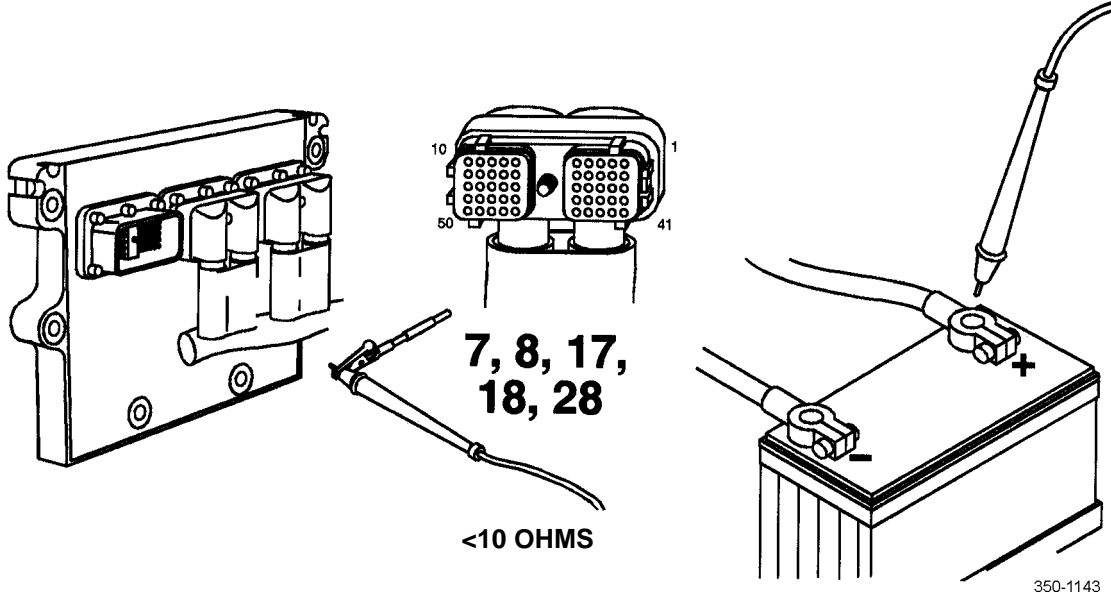
MALFUNCTION	TEST OR INSPECTION	CORRECTIVE ACTION
<p>Error Code 1343 - Engine ECU (794) Internal Communication Failure - Continued.</p>	<p>e. Measure resistance from engine harness connector pin 28 to positive (+) battery terminal. Resistance should be less than 10 Ohms.</p> 	<p>5. Check all ground resistances:</p> <ul style="list-style-type: none"> a. Measure resistance from engine harness connector pin 29 to negative (-) battery terminal. Resistance should be less than 10 Ohms. b. Measure resistance from engine harness connector pin 30 to negative (-) battery terminal. Resistance should be less than 10 Ohms. <ul style="list-style-type: none"> a. If resistance is not as specified, repair engine harness connectors (WP 0113 00). b. Notify Sustainment Maintenance to replace engine harness.

Table 6. Error 1343 - Engine ECU (794) Internal Communication Failure
Troubleshooting Procedures - Continued.

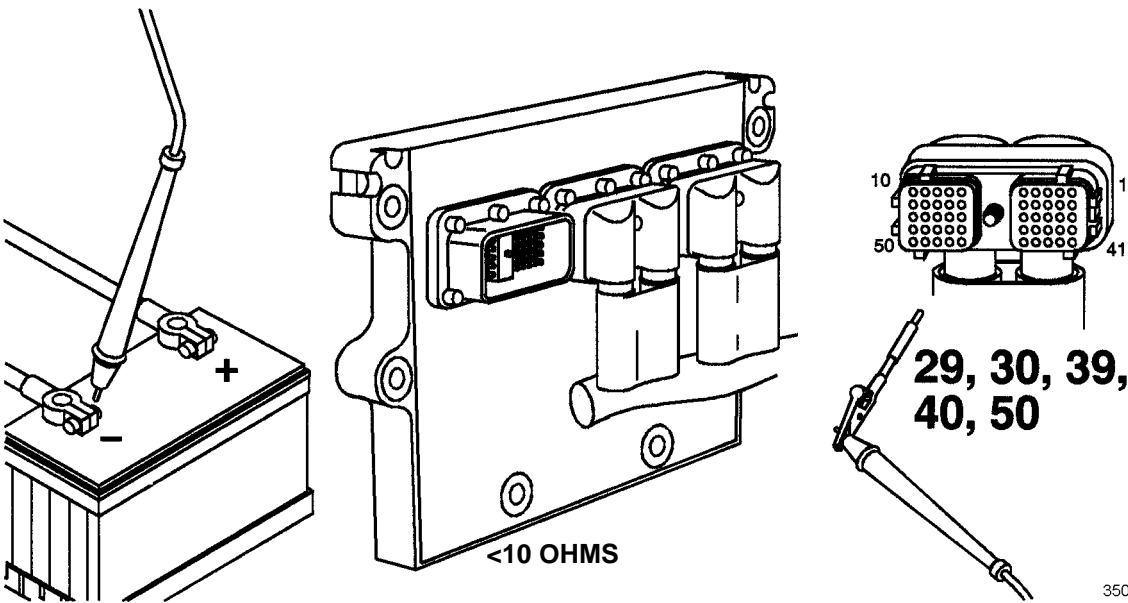
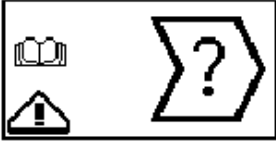
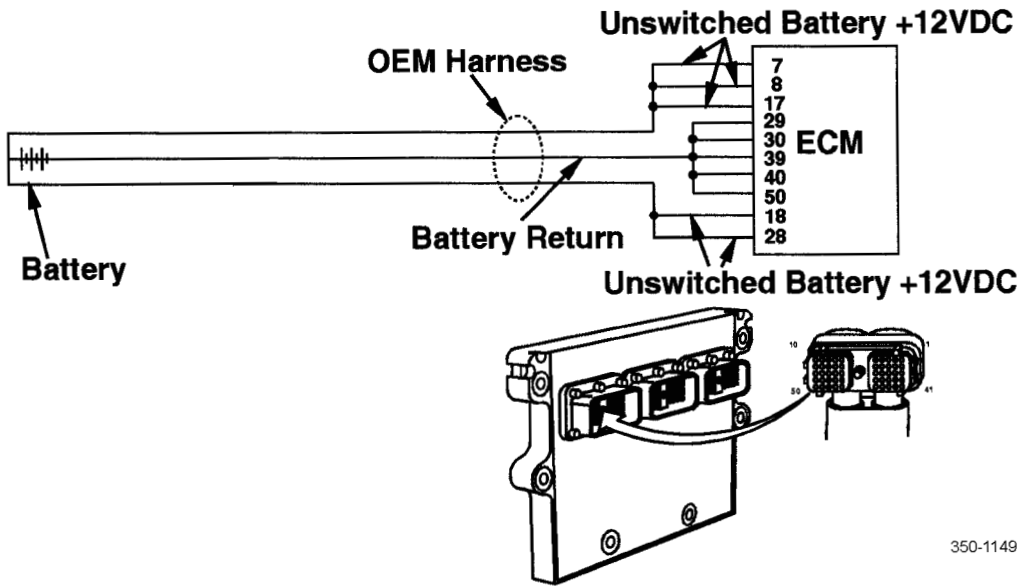
MALFUNCTION	TEST OR INSPECTION	CORRECTIVE ACTION
<p data-bbox="159 472 690 535">Error Code 1343 - Engine ECU (794) Internal Communication Failure - Continued.</p> 	<p data-bbox="755 472 1088 630">c. Measure resistance from engine harness connector pin 39 to negative (-) battery terminal. Resistance should be less than 10 Ohms.</p> <p data-bbox="755 1312 1088 1470">d. Measure resistance from engine harness connector pin 40 to negative (-) battery terminal. Resistance should be less than 10 Ohms.</p> <p data-bbox="755 1480 1088 1638">e. Measure resistance from engine harness connector pin 50 to negative (-) battery terminal. Resistance should be less than 10 Ohms.</p>	<p data-bbox="1169 1018 1388 1123">29, 30, 39, 40, 50</p> <p data-bbox="1356 1260 1437 1281">350-1148</p>

Table 7. Error Code 1346 - Engine ECU (794) Software Failure Troubleshooting Procedures.

MALFUNCTION	TEST OR INSPECTION	CORRECTIVE ACTION
<p data-bbox="159 443 717 499">Error Code 1346 - Engine ECU (794) Software Failure.</p> 	<p data-bbox="732 443 1086 533">Turn ignition switch to OFF position for 30 seconds and then back to ON position.</p>	<p data-bbox="1105 443 1458 533">Replace engine ECU (794) if error code still appears (WP 0079 00).</p>



350-1149

END OF WORK PACKAGE

ELECTRONIC CONTROL UNIT (ECU) SUPPLY VOLTAGE TROUBLESHOOTING

0016 00

THIS WORK PACKAGE COVERS

Error Code 451 - Voltage Supply Too High for Steering ECU (792)

Error Code 452 - Voltage Supply Too Low for Steering ECU (792)

Error Code 453 - Wheel Sensor Supply Voltage Out of Range (RESET or USMC only)

Error Code 454 - Wheel Sensor Supply Voltage Out of Range (RESET or USMC only)

Error Code 811 - Voltage Supply Too Low for Transmission ECU (793)

Error Code 812 - Voltage Supply Too High for Transmission ECU (793)

Error Code 813 - Voltage Failure at Transmission Gear-shift Valve Supply

Error Code 814 - Voltage Failure at Transmission Gear-shift Valve Supply

INITIAL SETUP

References

TM 10-3930-675-10

Current Supply (A34738.0200) (WP 0048 00-31)

References - Continued

ECS Steering (A34651.0200) (WP 0048 00-16)

ECU Transmission (A34650.0200) (WP 0048 00-12)

NOTE

Refer to WP 0004 00 for additional troubleshooting guidance, information, and illustrations that locate critical components.

Table 1. Error Code 451 - Voltage Supply Too High for Steering ECU (792) Troubleshooting Procedures.

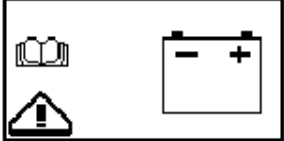
MALFUNCTION	TEST OR INSPECTION	CORRECTIVE ACTION
<p>Error Code 451 - Voltage Supply Too High for Steering ECU (792).</p> 	<p>Check output voltage from alternator.</p>	<p>If output voltage is greater than 33V, replace alternator (WP 0070 00).</p>

Table 2. Error Code 452 - Voltage Supply Too Low for Steering ECU (792) Troubleshooting Procedures.

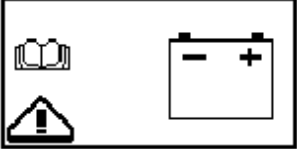
MALFUNCTION	TEST OR INSPECTION	CORRECTIVE ACTION
<p data-bbox="159 409 722 472">Error Code 452 - Voltage Supply Too Low for Steering ECU (792).</p> 	<ol style="list-style-type: none"> <li data-bbox="732 409 1092 472">1. Ensure circuit breakers F26 and F29 are not tripped. <li data-bbox="732 688 1092 814">2. Check voltage (22V to 26V) at connector X174 at pins 3 and 14 with the engine running (WP 0048 00-16). <li data-bbox="732 1052 1092 1178">3. Check for voltage (22V to 26V) at connector X174 at pins 3 and 14 with the engine running (WP 0048 00-16). <li data-bbox="732 1451 1092 1577">4. Check for voltage (22V to 26V) at ECU (792) at pins 1, 3, 4, and 5 with the ignition ON (WP 0048 00-16). 	<p data-bbox="1102 409 1365 436">Reset circuit breaker(s).</p> <ol style="list-style-type: none"> <li data-bbox="1102 688 1461 779">a. If voltage is found but less than 18V, check the condition and charge of the vehicle batteries. <li data-bbox="1102 785 1461 875">b. Check voltage output of alternator at either NATO slave receptacle. <li data-bbox="1102 882 1461 972">c. Charge or replace discharged vehicle batteries (WP 0108 00 and WP 0110 00). <li data-bbox="1102 978 1461 1035">d. Replace non-operational alternator (WP 0070 00). <li data-bbox="1102 1056 1461 1209">a. If no voltage (22V to 26V) is found at either pin, check circuit breakers F26 and F29 and continuity of wires A473, A478 (WP 0048 00-16). <li data-bbox="1102 1215 1461 1306">b. Replace damaged or non-operational circuit breaker (WP 0074 00). <li data-bbox="1102 1312 1461 1369">c. Repair or replace damaged connector (WP 0113 00). <li data-bbox="1102 1375 1461 1432">d. Replace damaged or open wire. <li data-bbox="1102 1453 1461 1543">a. If voltage (22V to 26V) is found, replace ECU (792) (WP 0080 00). <li data-bbox="1102 1549 1461 1703">b. If no voltage (22V to 26V) is found at any one pin, check continuity of wires A17414, 7923 and A1743A (WP 0048 00-16). <li data-bbox="1102 1709 1461 1766">c. Repair or replace damaged connector (WP 0113 00). <li data-bbox="1102 1772 1461 1829">d. Replace damaged or open wire.

Table 3. Error Code 453 - Wheel Sensor Supply Voltage Out of Range (RESET or USMC Only) Troubleshooting Procedures.

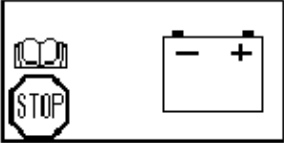
MALFUNCTION	TEST OR INSPECTION	CORRECTIVE ACTION
<p data-bbox="159 443 719 499">Error Code 453 - Wheel Sensor Supply Voltage Out of Range (RESET or USMC Only).</p> 	<ol style="list-style-type: none"> <li data-bbox="732 443 1088 562">1. Check for voltage (5V) at connector X171 between pins 4 and 6, and 12 and 14 (WP 0048 00-20). <li data-bbox="732 806 1088 926">2. Check for voltage (5V) at connector X170 at pins 4 and 6, and 12 and 14 (WP 0048 00-21). <li data-bbox="732 1077 1088 1262">3. Check for continuity. Disconnect connector X170 and check for continuity to ground at pins 4 and 12 (WP 0048 00-21). There should not be continuity to ground. <li data-bbox="732 1444 1088 1629">4. Check for continuity. Disconnect all of the numbered wires from connector X192 and check each one for continuity to ground (WP 0048 00-21). 	<p data-bbox="1104 443 1464 499">If voltage (5V) is not found, perform the following checks:</p> <ol style="list-style-type: none"> <li data-bbox="1104 506 1464 625">a. Disconnect connector X170 and recheck for voltage at X171 between pins 4 and 6, and 12 and 14. <li data-bbox="1104 632 1464 688">b. If voltage (5V) is still not found, perform step 2. <li data-bbox="1104 695 1464 789">c. If voltage (5V) returns after disconnecting X170, perform step 3. <p data-bbox="1104 806 1464 863">If voltage (5V) is not found, perform the following checks:</p> <ol style="list-style-type: none"> <li data-bbox="1104 869 1464 989">a. Disconnect connector X171 and recheck for voltage at X170 between pins 4 and 6, and 12 and 14. <li data-bbox="1104 995 1464 1052">b. If voltage (5V) is still not found, perform step 5. <ol style="list-style-type: none"> <li data-bbox="1104 1077 1464 1230">a. If continuity to ground is found at pin 4, disconnect wire BU from connector X192 pin 4 and recheck (WP 0048 00-21). <li data-bbox="1104 1236 1464 1356">b. If continuity to ground is found at pin 12, disconnect wire OR from connector X192 pin 12 and recheck (WP 0048 00-21). <li data-bbox="1104 1362 1464 1419">c. Replace grounded X170 to X192 cable (WP 0113 00). <p data-bbox="1104 1444 1464 1598">If continuity to ground is found at any numbered wire, determine which wheel sensor it belongs to. Replace grounded wheel sensor (WP 0104 00).</p>

Table 3. Error Code 453 - Wheel Sensor Supply Voltage Out of Range Troubleshooting Procedures (RESET or USMC Only) - Continued.

MALFUNCTION	TEST OR INSPECTION	CORRECTIVE ACTION
<p>Error Code 453 - Wheel Sensor Supply Voltage Out of Range (RESET or USMC Only) - Continued.</p>	<p>5. Check for continuity. Disconnect connector X171 and check for continuity to ground at pins 4 and 12 (WP 0048 00-20). There should not be continuity to ground.</p> <p>6. Check for continuity. Disconnect all of the numbered wires from connector X167 that go to the front wheel sensors and check each one for continuity to ground (WP 0048 00-20).</p> <p>7. Check for continuity. Disconnect connector X170 and X171. Disconnect ECU (792) pins 138, 139, 140 and 141. Check wires A1714, A17112 (WP 0048 00-20), A1704, and A17012 (WP 0048 00-21) for continuity to ground.</p>	<p>a. If continuity to ground is found at pin 4, disconnect wire BU from connector X167 pin 4 and recheck (WP 0048 00-20).</p> <p>b. If continuity to ground is found at pin 12, disconnect wire OR from connector X167 pin 12 and recheck (WP 0048 00-20).</p> <p>c. Replace grounded X171 to X167 cable (WP 0113 00).</p> <p>If continuity to ground is found at any numbered wire, determine which wheel sensor it belongs to. Replace grounded wheel sensor (WP 0104 00).</p> <p>a. Replace grounded wire.</p> <p>b. Repair or replace damaged connector (WP 0113 00).</p> <p>c. Replace damaged ECU (792) terminal board (WP 0080 00).</p> <p>d. Replace ECU (792) (WP 0080 00).</p>

Table 4. Error Code 454 - Wheel Sensor Supply Voltage Out of Range (RESET or USMC Only) Troubleshooting Procedures.

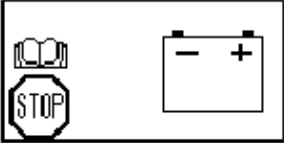
MALFUNCTION	TEST OR INSPECTION	CORRECTIVE ACTION
<p>Error Code 454 - Wheel Sensor Supply Voltage Out of Range (RESET or USMC Only).</p> 	<ol style="list-style-type: none"> 1. Check for voltage (5V) at connector X171 between pins 1 and 3 and 9 and 11 (WP 0048 00-20). 2. Check for voltage (5V) at connector X170 between pins 1 and 3, and 9 and 11 (WP 0048 00-21). 3. Check for continuity. Disconnect connector X170 and check for continuity to ground at pins 1 and 9 (WP 0048 00-21). There should not be continuity to ground. 4. Check for continuity. Disconnect all of the numbered wires from connector X192 and check each one for continuity to ground (WP 0048 00-21). 	<p>If voltage (5V) is not found, perform the following checks:</p> <ol style="list-style-type: none"> a. Disconnect connector X170 and recheck for voltage at X171 between pins 1 and 3 and 9 and 11. b. If voltage (5V) is still not found, perform step 2. c. If voltage (5V) returns after disconnecting X170, perform step 3. <p>If voltage (5V) is not found, perform the following checks:</p> <ol style="list-style-type: none"> a. Disconnect connector X171 and recheck for voltage at X170 between pins 1 and 3, and 9 and 11. b. If voltage (5V) is still not found, perform step 5. <ol style="list-style-type: none"> a. If continuity to ground is found at pin 1, disconnect wire GY from connector X192 pin 1 and recheck (WP 0048 00-21). b. If continuity to ground is found at pin 9, disconnect wire BN from connector X192 pin 9 and recheck (WP 0048 00-21). c. Replace grounded X170 to X192 cable (WP 0113 00). <p>If continuity to ground is found at any numbered wire, determine which wheel sensor it belongs to. Replace grounded wheel sensor (WP 0104 00).</p>

Table 4. Error Code 454 - Wheel Sensor Supply Voltage Out of Range (RESET or USMC Only) Troubleshooting Procedures - Continued.

MALFUNCTION	TEST OR INSPECTION	CORRECTIVE ACTION
<p>Error Code 454 - Wheel Sensor Supply Voltage Out of Range (RESET or USMC Only) - Continued.</p>	<p>5. Check for continuity. Disconnect connector X171 and check for continuity to ground at pins 1 and 9 (WP 0048 0020). There should not be continuity to ground.</p> <p>6. Check continuity. Disconnect all of the numbered wires from connector X167 that go to the front wheel sensors and check each one for continuity to ground (WP 0048 00-20).</p> <p>7. Check for continuity. Disconnect connector X170 and X171. Disconnect ECU (792) pins 86, 87, 88, and 89. Check wires A1711, A1719 (WP 0048 00-20), A1701, and A1709 (WP 0048 00-21) for continuity to ground.</p>	<p>a. If continuity to ground is found at pin 1, disconnect wire GY from connector X167 pin 1 and recheck (WP 0048 00-20).</p> <p>b. If continuity to ground is found at pin 9, disconnect wire BN from connector X167 pin 12 and recheck (WP 0048 00-20).</p> <p>c. Replace grounded X171 to X167 cable (WP 0113 00).</p> <p>If continuity to ground is found at any numbered wire, determine which wheel sensor it belongs to. Replace grounded wheel sensor (WP 0104 00).</p> <p>a. Replace grounded wire.</p> <p>b. Repair or replace damaged connector (WP 0113 00).</p> <p>c. Replace damaged ECU (792) terminal board (WP 0080 00).</p> <p>d. Replace ECU (792) (WP 0080 00).</p>

Table 5. Error Code 811 - Voltage Supply Too Low for Transmission ECU (793) Troubleshooting Procedures.

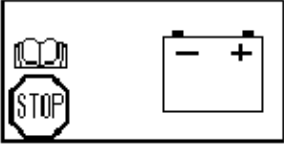
MALFUNCTION	TEST OR INSPECTION	CORRECTIVE ACTION
<p data-bbox="159 407 717 470">Error Code 811 - Voltage Supply Too Low for Transmission ECU (793).</p> 	<ol style="list-style-type: none"> <li data-bbox="735 407 1089 470">1. Ensure circuit breakers F27 and F28 are not tripped. <li data-bbox="735 709 1089 831">2. Check for voltage (22V to 26V) at connector X174 at pins 1 and 2 with the engine running (WP 0048 00-16). <li data-bbox="735 1094 1089 1215">3. Check for voltage (22V to 26V) at connector 174 at pins 1 and 2 with the engine running (WP 0048 00-16). <li data-bbox="735 1444 1089 1566">4. Check for voltage (22V to 26V) at ECU (793) at pins 23, 45, and 68 with the ignition ON (WP 0048 00-12). 	<p data-bbox="1109 407 1365 438">Reset circuit breaker(s).</p> <ol style="list-style-type: none"> <li data-bbox="1109 709 1463 800">a. If voltage is found but less than 18V, check the condition and charge of the vehicle batteries. <li data-bbox="1109 800 1463 890">b. Check voltage output of alternator at either NATO slave receptacle. <li data-bbox="1109 890 1463 980">c. Charge or replace discharged vehicle batteries (WP 0108 00 and WP 0110 00). <li data-bbox="1109 980 1463 1071">d. Replace defective alternator (WP 0070 00 and WP 0071 00). <li data-bbox="1109 1094 1463 1245">a. If no voltage (22V to 26V) is found at either pin, check circuit breakers F27 and F28 and continuity of wires A471 and A472 (WP 0048 00-12). <li data-bbox="1109 1245 1463 1304">b. Replace damaged or defective circuit breaker (WP 0074 00). <li data-bbox="1109 1304 1463 1362">c. Repair or replace damaged connector (WP 0113 00). <li data-bbox="1109 1362 1463 1421">d. Replace damaged or open wire. <li data-bbox="1109 1444 1463 1535">a. If voltage (22V to 26V) is found, replace ECU (793) (WP 0080 00). <li data-bbox="1109 1535 1463 1686">b. If no voltage (22V to 26V) is found at any one pin, check continuity of wires A1741A, A1741B, and A1742A (WP 0048 00-12). <li data-bbox="1109 1686 1463 1745">c. Repair or replace damaged connector (WP 0113 00). <li data-bbox="1109 1745 1463 1803">d. Replace damaged or open wire.

Table 6. Error Code 812 - Voltage Supply Too High for Transmission ECU (793) - Troubleshooting Procedures.

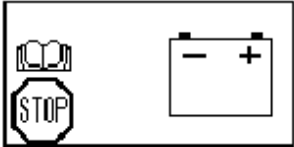
MALFUNCTION	TEST OR INSPECTION	CORRECTIVE ACTION
<p data-bbox="159 407 717 468">Error Code 812 - Voltage Supply Too High for Transmission ECU (793).</p> 	<p data-bbox="730 407 1091 468">Check output voltage from alternator.</p>	<p data-bbox="1104 407 1456 499">If output voltage is higher than 26V, replace alternator (WP 0070 00).</p>

Table 7. Error Code 813 - Voltage Failure at Transmission Gearshift Valve Power Supply Troubleshooting Procedures.

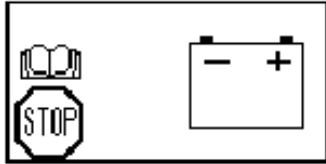
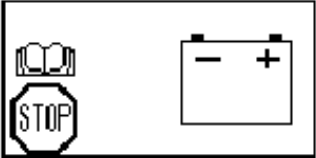
MALFUNCTION	TEST OR INSPECTION	CORRECTIVE ACTION
<p data-bbox="159 806 717 867">Error Code 813 - Voltage Failure at Transmission Gearshift Valve Supply.</p> 	<ol style="list-style-type: none"> <li data-bbox="730 806 1091 867">1. Ensure circuit breaker F27 is not tripped. <li data-bbox="730 1100 1091 1224">2. Check for voltage (22V to 26V) at connector X174 at pin 1 with the engine running (WP 0048 00-16). <li data-bbox="730 1465 1091 1682">3. Disconnect ECU (793) and inspect ECU and connector pins for damage. Check for voltage (22V to 26V) on the ECU (793) connector at pins 23 and 68 with the ignition ON (WP 0048 00-12). 	<p data-bbox="1104 806 1344 835">Reset circuit breakers.</p> <ol style="list-style-type: none"> <li data-bbox="1104 1100 1463 1255">a. If no voltage (22V to 26V) is found, check circuit breaker F27 and continuity of wires A471 (WP 0048 00-32) and 471 (WP 0048 00-12). <li data-bbox="1104 1262 1463 1318">b. Replace damaged or defective circuit breaker (WP 0074 00). <li data-bbox="1104 1325 1463 1381">c. Repair or replace damaged connector (WP 0113 00). <li data-bbox="1104 1388 1463 1444">d. Replace damaged or open wire. <li data-bbox="1104 1465 1463 1621">a. If no voltage (22V to 26V) is found at any one pin, check continuity of wires A1471A and A1741B (WP 0048 00-12). <li data-bbox="1104 1627 1463 1684">b. Repair or replace damaged connector (WP 0113 00). <li data-bbox="1104 1690 1463 1747">c. Replace damaged or open wire. <li data-bbox="1104 1753 1463 1843">d. If voltage (22V to 26V) is found, replace ECU (793) (WP 0080 00).

Table 8. Error Code 814 - Voltage Failure at Transmission Gearshift Valve Power Supply Troubleshooting Procedures.

MALFUNCTION	TEST OR INSPECTION	CORRECTIVE ACTION
<p>Error Code 814 - Voltage Failure at Transmission Gearshift Valve Power Supply.</p> 	<p>Perform troubleshooting procedure for error code 813.</p>	

END OF WORK PACKAGE

THIS WORK PACKAGE COVERS

- | | |
|--|--|
| Error Code 350 - Right Front Wheel Valve Solenoid Error | Error Code 409 - Locked Twistlock Control Lamp, Short Circuit Failure |
| Error Code 351 - Right Rear Wheel Valve Solenoid Error | Error Code 410 - alignment Control Lamp, Short Circuit Failure |
| Error Code 352 - Left Rear Wheel Valve Solenoid Error | Error Code 412 - Auto Lube Pump Control, Short Circuit Failure - USMC Only |
| Error Code 353 - Left Front Wheel Valve Solenoid Error | Error Code 413 - Boom Folding Supply Valve, Short Circuit Failure |
| Error Code 354 - Right Front Wheel Valve Solenoid Error | Error Code 415 - Drag Restriction, Short Circuit Failure |
| Error Code 355 - Right Rear Wheel Valve Solenoid Error | Error Code 416 - Steering Pressure Switch, Circuit Input Error |
| Error Code 356 - Left Rear Wheel Valve Solenoid Error | Error Code 418 - 2WD Steering Selection Switch, Circuit Input Error |
| Error Code 357 - Right Front Wheel Valve Solenoid Error | Error Code 419 - 4WD Steering Selection Switch, Circuit Input Error |
| Error Code 399 - EEPROM Parameter Error in ECU (792) | Error Code 420 - Crab Steering Selection Switch, Circuit Input Error |
| Error Code 401 - Transmission Neutral Signal from Steering ECU (792) Short Circuit Failure | Error Code 422 - Cab in Transport Proximity Switch, Circuit Input Error |
| Error Code 404 - 2WD Steering Control Lamp, Short Circuit Failure | Error Code 423 - Ether Start Kit Switch, Circuit Failure |
| Error Code 405 - 4WD Steering Control Lamp, Short Circuit Failure | Error Code 427 - Tophandler Work Light Switch, Circuit Input Error |
| Error Code 406 - Crab Steering Control Lamp, Short Circuit Failure | Error Code 440 - Steering Wheel Sensor, Power Supply Error (RESET or USMC Only) |
| Error Code 408 - Unlocked Twistlock Control Lamp, Short Circuit Failure | Error Code 450 - Temperature Inside Steering ECU (792) Above Critical Threshold [184°F (85°C)] |

INITIAL SETUP

References

- TM 10-3930-675-10
- Current Supply (A34738.0200) (WP 0048 00-31)
- Auxiliary Pump (A34746.0200) (WP 0048 00-47)
- ECS Electrical Servo (A34648.0200) (WP 0048 00-5)

References - Continued

- ECS Steering (A34651.0200) (WP 0048 00-16)
- ECS Hydraulics (A34654.0200) (WP 0048 00-29)
- ECS Attachment (A34652.0200) (WP 0048 00-23)

NOTE

Refer to WP 0004 00 for additional troubleshooting guidance, information, and illustrations that locate critical components.

Table 1. Error Code 350 - Right Front Wheel Valve Solenoid Error Troubleshooting Procedures.

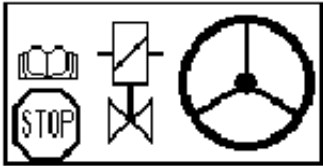
MALFUNCTION	TEST OR INSPECTION	CORRECTIVE ACTION
<p>Error Code 350 - Right Front Wheel Valve Solenoid Error.</p> 	<p style="text-align: center;">NOTE</p> <p>Error code 350 activates when the resistance of the solenoid or circuit is out of range from the preset value. This error code is programmed for USMC vehicles only.</p>	<p>Perform troubleshooting procedure for error code 329.</p>

Table 2. Error Code 351 - Right Rear Wheel Valve Solenoid Error Troubleshooting Procedures.

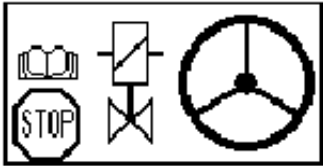
MALFUNCTION	TEST OR INSPECTION	CORRECTIVE ACTION
<p>Error Code 351 - Right Rear Wheel Valve Solenoid Error.</p> 	<p style="text-align: center;">NOTE</p> <p>Error code 351 activates when the resistance of the solenoid or circuit is out of range from the preset value. This error code is programmed for USMC vehicles only.</p>	<p>Perform troubleshooting procedure for error code 330.</p>

Table 3. Error Code 352 - Left Rear Wheel Valve Solenoid Error Troubleshooting Procedures.

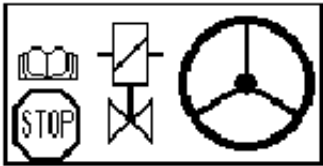
MALFUNCTION	TEST OR INSPECTION	CORRECTIVE ACTION
<p>Error Code 352 - Left Rear Wheel Valve Solenoid Error.</p> 	<p style="text-align: center;">NOTE</p> <p>Error code 352 activates when the resistance of the solenoid or circuit is out of range from the preset value. This error code is programmed for USMC vehicles only.</p>	<p>Perform troubleshooting procedure for error code 331.</p>

Table 4. Error Code 353 - Left Front Wheel Valve Solenoid Error Troubleshooting Procedures.

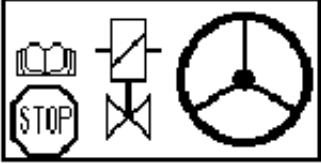
MALFUNCTION	TEST OR INSPECTION	CORRECTIVE ACTION
<p>Error Code 353 - Left Front Wheel Valve Solenoid Error.</p> 	<p style="text-align: center;">NOTE</p> <p>Error code 353 activates when the resistance of the solenoid or circuit is out of range from the preset value. This error code is programmed for USMC vehicles only.</p>	<p>Perform troubleshooting procedure for error code 332.</p>

Table 5. Error Code 354 - Right Front Wheel Valve Solenoid Error Troubleshooting Procedures.

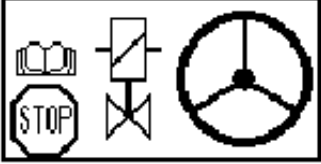
MALFUNCTION	TEST OR INSPECTION	CORRECTIVE ACTION
<p>Error Code 354 - Right Front Wheel Valve Solenoid Error.</p> 	<p style="text-align: center;">NOTE</p> <p>Error code 354 activates when the solenoid current control initialization fails. This code typically is activated after ECU (792) has been replaced. This error code is programmed for USMC vehicles only.</p>	<p>Press reset. If recurring error code activates, replace ECU (792) (WP 0080 00).</p>

Table 6. Error Code 355 - Right Rear Wheel Valve Solenoid Error Troubleshooting Procedures.

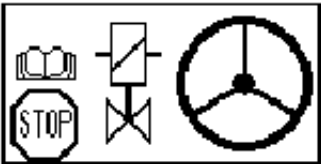
MALFUNCTION	TEST OR INSPECTION	CORRECTIVE ACTION
<p>Error Code 355 - Right Rear Wheel Valve Solenoid Error.</p> 	<p style="text-align: center;">NOTE</p> <p>Error code 355 activates when the solenoid current control initialization fails. This code typically is activated after ECU (792) has been replaced. This error code is programmed for USMC vehicles only.</p>	<p>Press reset. If recurring error code activates, replace ECU (792) (WP 0080 00).</p>

Table 7. Error Code 356 - Left Rear Wheel Valve Solenoid Error Troubleshooting Procedures.

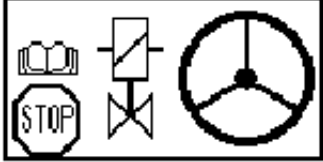
MALFUNCTION	TEST OR INSPECTION	CORRECTIVE ACTION
<p>Error Code 356 - Left Rear Wheel Valve Solenoid Error.</p> 	<p style="text-align: center;">NOTE</p> <p>Error code 356 activates when the solenoid current control initialization fails. This code typically is activated after ECU (792) has been replaced. This error code is programmed for USMC vehicles only.</p> <p style="text-align: right;">Press reset. If recurring error code activates, replace ECU (792) (WP 0080 00).</p>	

Table 8. Error Code 357 - Right Front Wheel Valve Solenoid Error Troubleshooting Procedures.

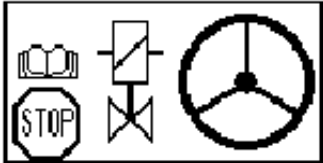
MALFUNCTION	TEST OR INSPECTION	CORRECTIVE ACTION
<p>Error Code 357 - Right Front Wheel Valve Solenoid Error.</p> 	<p style="text-align: center;">NOTE</p> <p>Error code 357 activates when the solenoid current control initialization fails. This code typically is activated after ECU (792) has been replaced. This error code is programmed for USMC vehicles only.</p> <p style="text-align: right;">Press reset. If recurring error code activates, replace ECU (792) (WP 0080 00).</p>	

Table 9. Error Code 399 - EEPROM Parameter Error in ECU (792) Troubleshooting Procedures.

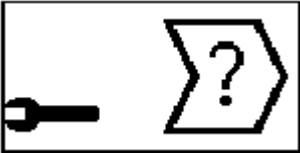
MALFUNCTION	TEST OR INSPECTION	CORRECTIVE ACTION
<p>Error Code 399 - EEPROM Parameter Error in ECU (792).</p> 	<p style="text-align: center;">NOTE</p> <p>Error code 399 activates when one or more EEPROM parameter values are out of range. This error code is programmed for USMC vehicles only.</p> <p style="text-align: right;">Press reset. If recurring error code activates, replace ECU (792) (WP 0080 00).</p>	

Table 10. Error Code 401 - Transmission Neutral Signal from Steering ECU (792) Short Circuit Failure Troubleshooting Procedures.


MALFUNCTION	TEST OR INSPECTION	CORRECTIVE ACTION
<p>Error Code 401 - Transmission Neutral Signal from Steering ECU (792) Short Circuit Failure.</p> 	<p>Check for continuity to ground on wire A79344 between steering ECU (792) pin 71 (WP 0048 00-16) and transmission ECU (793) pin 44 (WP 0048 00-13).</p>	<p>If continuity is present, replace wire A79344.</p>

Table 11. Error Code 404 - 2WD Steering Control Lamp, Short Circuit Failure Troubleshooting Procedures.

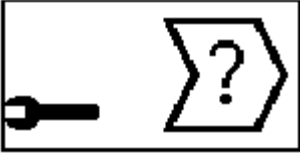
MALFUNCTION	TEST OR INSPECTION	CORRECTIVE ACTION
<p>Error Code 404 - 2WD Steering Control Lamp, Short Circuit Failure.</p> 	<p style="text-align: center;">NOTE</p> <p>Error code 404 is an information type error code. It may not activate for the operator. The operator may report the indicator light is not working. Enter DIAG STEERING 2(16) in the Diagnostic menu to verify the code or enable the information type code in the Initialization menu.</p> <ol style="list-style-type: none"> 1. Inspect the 2-wheel drive selection switch for damage. 2. Inspect light bulb. Remove the screws from the menu selection button panel on the steering column console. Lift the panel to access the 2-wheel drive selection button. Pull the light socket down and out from the console. Remove the light bulb and inspect (WP 0073 00). 3. Disconnect connector X177 located in the middle panel. Should not have continuity to ground. Check for continuity to ground on the loose part of X177 at pin 1 (WP 0048 00-19). 	<p>Replace damaged steering selection switch (WP 0073 00).</p> <p>Replace damaged or shorted light bulb (WP 0073 00).</p> <ol style="list-style-type: none"> a. If continuity to ground is found, disconnect X153 and recheck. b. If continuity to ground is still found, check wires 1601 and A1531 for continuity to ground (WP 0048 00-19). c. Replace grounded X177 to X160 cable or grounded wire A1531.

Table 11. Error Code 404 - 2WD Steering Control Lamp, Short Circuit Failure Troubleshooting Procedures - Continued.

MALFUNCTION	TEST OR INSPECTION	CORRECTIVE ACTION
Error Code 404 - 2WD Steering Control Lamp, Short Circuit Failure - Continued.	4. Check for continuity to ground on the loose part of X153 at pin 1 (WP 0048 00-19). There should not be continuity to ground. 5. Check ECU (792) pin 68 for connection or damage (WP 0048 00-19).	a. If continuity to ground is found, replace the X153 to steering column harness (WP 0073 00). b. If continuity to ground is not found, check wire A1771 for continuity to ground (WP 0048 00-19). c. Replace grounded wire A1771. a. Replace damaged ECU (792) terminal board (WP 0080 00). b. Replace ECU (792) (WP 0080 00).

Table 12. Error Code 405 - 4WD Steering Control Lamp, Short Circuit Failure Troubleshooting Procedures.

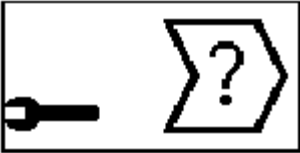
MALFUNCTION	TEST OR INSPECTION	CORRECTIVE ACTION
Error Code 405 - 4WD Steering Control Lamp, Short Circuit Failure. 	<p style="text-align: center;">NOTE</p> <p>Error code 405 is an information type error code. It may not activate for the operator. The operator may report the indicator light is not working. Enter DIAG STEERING 2(16) in the Diagnostic menu to verify the code or enable the information type code in the Initialization menu.</p>	
	1. Inspect the 4-wheel drive selection switch for damage. 2. Inspect light bulb. Remove the screws from the menu selection button panel on the steering column console. Lift the panel to access the 4-wheel drive selection button. Pull the light socket down and out from the console.	Replace damaged steering selection switch (WP 0073 00). Replace damaged or shorted light bulb (WP 0073 00).

Table 12. Error Code 405 - 4WD Steering Control Lamp, Short Circuit Failure Troubleshooting Procedures - Continued.

MALFUNCTION	TEST OR INSPECTION	CORRECTIVE ACTION
<p>Error Code 405 - 4WD Steering Control Lamp, Short Circuit Failure - Continued.</p>	<p>3. Check for continuity. Disconnect connector X177 located in the middle panel. Check for continuity to ground on the loose part of X177 at pin 2 (WP 0048 00-19). There should not be continuity to ground.</p> <p>4. Check for continuity to ground on the loose part of X153 at pin 2 (WP 0048 00-19). There should not be continuity to ground.</p> <p>5. Check ECU (792) pin 67 for connection or damage (WP 0048 00-19).</p>	<p>a. If continuity to ground is found, disconnect X153 and recheck.</p> <p>b. If continuity to ground is still found, check wires 1602 and A1532 for continuity to ground (WP 0048 00-19).</p> <p>c. Replace grounded X177 to X160 cable or grounded wire A1532.</p> <p>a. If continuity to ground is found, replace the X153 to steering column harness (WP 0073 00).</p> <p>b. If continuity to ground is not found, check wire A1772 for continuity to ground (WP 0048 00-19).</p> <p>c. Replace grounded wire A1772.</p> <p>a. Replace damaged ECU (792) terminal board (WP 0080 00 00).</p> <p>b. Replace ECU (792) (WP 0080 00).</p>

Table 13. Error Code 406 - Crab Steering Control Lamp, Short Circuit Failure Troubleshooting Procedures.

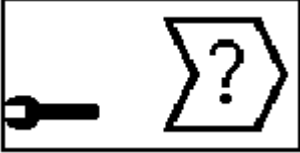
MALFUNCTION	TEST OR INSPECTION	CORRECTIVE ACTION
<p data-bbox="159 443 719 499">Error Code 406 - Crab Steering Control Lamp, Short Circuit Failure.</p> 	<p data-bbox="1045 443 1146 474" style="text-align: center;">NOTE</p> <p data-bbox="781 489 1414 674">Error code 406 is an information type error code. It may not activate for the operator. The operator may report the indicator light is not working. Enter DIAG STEERING 2(16) in the Diagnostic menu to verify the code or enable the information type codes in the initialization menu.</p> <ol style="list-style-type: none"> <li data-bbox="735 695 1089 758">1. Inspect the crab steering selection switch for damage. <li data-bbox="735 779 1089 1024">2. Inspect light bulb. Remove the screws from the menu selection button panel on the steering column console. Lift the panel to access the crab steering selection button. Pull the light socket down and out from the console. <li data-bbox="735 1045 1089 1291">3. Check for continuity. Disconnect connector X177 located in the middle panel. Check for continuity to ground on the loose part of X177 at pin 3 (WP 0048 00-19). There should not be continuity to ground. <li data-bbox="735 1312 1089 1537">4. Check for continuity to ground on the loose part of X153 at pin 3 (WP 0048 00-19). There should not be continuity to ground. <li data-bbox="735 1558 1089 1803">5. Check ECU (792) pin 66 for connection or damage (WP 0048 00-19). 	<p data-bbox="1105 695 1458 758">Replace damaged steering selection switch (WP 0073 00).</p> <p data-bbox="1105 779 1458 835">Replace damaged or shorted light bulb (WP 0073 00).</p> <ol style="list-style-type: none"> <li data-bbox="1105 1045 1466 1136">a. If continuity to ground is found, disconnect X153 and recheck. <li data-bbox="1105 1136 1466 1262">b. If continuity to ground is still found, check wires 1603 and A1533 for continuity to ground (WP 0048 00-19). <li data-bbox="1105 1262 1466 1352">c. Replace grounded X177 to X160 cable or grounded wire A 1533. <li data-bbox="1105 1373 1466 1499">a. If continuity to ground is found, replace the X153 to steering column harness (WP 0073 00). <li data-bbox="1105 1499 1466 1625">b. If continuity to ground is not found, check wire A1733 for continuity to ground (WP 0048 00-19). <li data-bbox="1105 1625 1466 1682">c. Replace grounded wire A1733. <li data-bbox="1105 1703 1466 1766">a. Replace damaged ECU (792) terminal board (WP 0080 00). <li data-bbox="1105 1766 1466 1829">b. Replace ECU (792) (WP 0080 00).

Table 14. Error Code 408 - Unlocked Twistlock Control Lamp Short, Circuit Failure Troubleshooting Procedures.

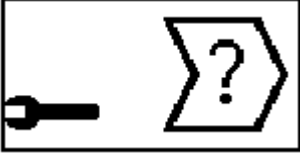
MALFUNCTION	TEST OR INSPECTION	CORRECTIVE ACTION
<p data-bbox="147 432 724 499">Error Code 408 - Unlocked Twistlock Control Lamp, Short Circuit Failure.</p> 	<p data-bbox="1045 432 1146 468" style="text-align: center;">NOTE</p> <p data-bbox="777 485 1414 674">Error code 408 is an information type error code. It may not activate for the operator. The operator may report the indicator light is not working. Enter DIAG STEERING 2(16) in the Diagnostic menu to verify the code or enable the information type codes in the initialization menu.</p> <ol style="list-style-type: none"> <li data-bbox="732 695 1089 758">1. Inspect the twistlock indicator lights for damage. <li data-bbox="732 772 1089 961">2. Check light fixtures. Access twistlock indicator lights (WP 0073 00) in the steering column console. Inspect twistlock indicator light sockets, bulbs, and wiring. <li data-bbox="732 976 1089 1234">3. Check for continuity. Disconnect connector X177 located in the middle panel. Check for continuity to ground on the loose part of X177 at pin 4 (WP 0048 00-19). There should not be continuity to ground. <li data-bbox="732 1312 1089 1472">4. Check for continuity to ground on the loose part of X153 at pin 4 (WP 0048 00-19). There should not be continuity to ground. <li data-bbox="732 1648 1089 1738">5. Check ECU (792) pin 64 for connection or damage (WP 0048 00-19) 	<p data-bbox="1096 695 1455 758">Replace damaged twistlock indicator light(s) (WP 0073 00).</p> <p data-bbox="1096 772 1455 863">Replace damaged or shorted light bulb, socket, or wiring (WP 0073 00).</p> <ol style="list-style-type: none"> <li data-bbox="1096 976 1455 1073">a. If continuity to ground is found, disconnect X153 and recheck. <li data-bbox="1096 1073 1455 1199">b. If continuity to ground is still found, check wires 1604 and A1534 for continuity to ground (WP 0048 00-19). <li data-bbox="1096 1199 1455 1297">c. Replace grounded X177 to X160 cable or grounded wire A1534. <ol style="list-style-type: none"> <li data-bbox="1096 1312 1455 1438">a. If continuity to ground is found, replace the X153 to steering column harness (WP 0073 00). <li data-bbox="1096 1438 1455 1564">b. If continuity to ground is not found, check wire A1774 for continuity to ground (WP 0048 00-19). <li data-bbox="1096 1564 1455 1627">c. Replace grounded wire A1774. <ol style="list-style-type: none"> <li data-bbox="1096 1648 1455 1738">a. Replace damaged ECU (792) terminal board (WP 0080 00 00). <li data-bbox="1096 1738 1455 1801">b. Replace ECU (792) (WP 0080 00).

Table 15. Error Code 409 - Locked Twistlock Control Lamp, Short Circuit Failure Troubleshooting Procedures.

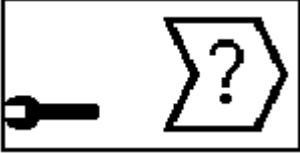
MALFUNCTION	TEST OR INSPECTION	CORRECTIVE ACTION
<p>Error Code 409 - Locked Twistlock Control Lamp, Short Circuit Failure.</p> 	<p style="text-align: center;">NOTE</p> <p>Error code 409 is an information type error code. It may not activate for the operator. The operator may report the indicator light is not working. Enter DIAG STEERING 2(16) in the Diagnostic menu to verify the code or enable the information type codes in the initialization menu.</p> <ol style="list-style-type: none"> 1. Inspect the twistlock indicator lights for damage. 2. Check light fixtures. Access twistlock indicator lights (WP 0073 00) in the steering column console. Inspect twistlock indicator light sockets, bulbs, and wiring. 3. Check for continuity. Disconnect connector X177 located in the middle panel. Check for continuity to ground on the loose part of X177 at pin 6 (WP 0048 00-19). There should not be continuity to ground. 4. Check for continuity to ground on the loose part of X153 at pin 6 (WP 0048 00-19). There should not be continuity to ground. 5. Check ECU (792) pin 63 for connection or damage (WP 0048 00-19). 	<ol style="list-style-type: none"> a. Replace damaged twistlock indicator light(s) (WP 0073 00). Replace damaged or shorted light bulb, socket, or wiring (WP 0073 00). a. If continuity to ground is found, disconnect X153 and recheck. b. If continuity to ground is still found, check wires 1606 and A1536 for continuity to ground (WP 0048 00-19). c. Replace grounded X177 to X160 cable or grounded wire A1536. a. If continuity to ground is found, replace the X153 to steering column harness (WP 0073 00). b. If continuity to ground is not found, check wire A1776 for continuity to ground (WP 0048 00-19). c. Replace grounded wire A1776. a. Replace damaged ECU (792) terminal board (WP 0080 00 00). b. Replace ECU (792) (WP 0080 00).

Table 16. Error Code 410 - Alignment Control Lamp, Short Circuit Failure Troubleshooting Procedures.

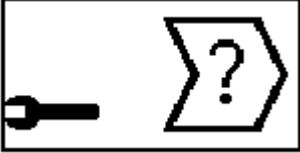
MALFUNCTION	TEST OR INSPECTION	CORRECTIVE ACTION
<p data-bbox="160 441 717 499">Error Code 410 - Alignment Control Lamp, Short Circuit Failure.</p> 	<p data-bbox="1045 441 1146 472" style="text-align: center;">NOTE</p> <p data-bbox="781 489 1414 674">Error code 410 is an information type error code. It may not activate for the operator. The operator may report the indicator light is not working. Enter DIAG STEERING 2(16) in the Diagnostic menu to verify the code or enable the information type codes in the initialization menu.</p> <ol style="list-style-type: none"> <li data-bbox="735 695 1089 758">1. Inspect the twistlock indicator lights for damage. <li data-bbox="735 779 1089 963">2. Check light fixtures. Access twistlock indicator lights (WP 0073 00) in the steering column console. Inspect twistlock indicator light sockets, bulbs, and wiring. <li data-bbox="735 984 1089 1232">3. Check for continuity. Disconnect connector X177 located in the middle panel. Check for continuity to ground on the loose part of X177 at pin 5 (WP 0048 00-19). There should not be continuity to ground. <li data-bbox="735 1316 1089 1472">4. Check for continuity to ground on the loose part of X153 at pin 5 (WP 0048 00-19). There should not be continuity to ground. <li data-bbox="735 1652 1089 1740">5. Check ECU (792) pin 62 for connection or damage (WP 0048 00-19). 	<p data-bbox="1105 695 1450 758">Replace damaged twistlock indicator light(s) (WP 0073 00).</p> <p data-bbox="1105 779 1450 867">Replace damaged or shorted light bulb, socket, or wiring (WP 0073 00).</p> <ol style="list-style-type: none"> <li data-bbox="1105 984 1450 1073">a. If continuity to ground is found, disconnect X153 and recheck. <li data-bbox="1105 1083 1450 1203">b. If continuity to ground is still found, check wires 1605 and A1535 for continuity to ground (WP 0048 00-19). <li data-bbox="1105 1213 1450 1299">c. Replace grounded X177 to X160 cable or grounded wire A1535. <ol style="list-style-type: none"> <li data-bbox="1105 1316 1450 1436">a. If continuity to ground is found, replace the X153 to steering column harness (WP 0073 00). <li data-bbox="1105 1446 1450 1566">b. If continuity to ground is not found, check wire A1775 for continuity to ground (WP 0048 00-19). <li data-bbox="1105 1577 1450 1629">c. Replace grounded wire A1775. <ol style="list-style-type: none"> <li data-bbox="1105 1652 1450 1740">a. Replace damaged ECU (792) terminal board (WP 0080 00 00). <li data-bbox="1105 1751 1450 1803">b. Replace ECU (792) (WP 0080 00).

Table 17. Error Code 412 - Autolube Pump Control, Short Circuit Failure (USMC Only) Troubleshooting Procedures.

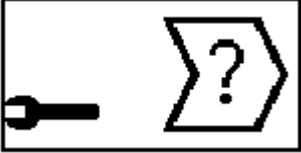
MALFUNCTION	TEST OR INSPECTION	CORRECTIVE ACTION
<p data-bbox="162 443 719 499">Error Code 412 - Autolube Pump Control, Short Circuit Failure (USMC Only).</p> 	<p data-bbox="1047 443 1146 474" style="text-align: center;">NOTE</p> <p data-bbox="781 489 1414 674">Error code 412 is an information type error code. It may not activate for the operator. The operator may report the auto lube pump is not working. Enter DIAG STEERING 2(16) in the Diagnostic menu to verify the code or enable the information type codes in the initialization menu.</p> <ol style="list-style-type: none"> <li data-bbox="735 695 1089 947">1. Test relay. Remove the plastic cover from the right rear of the cab to access the cab distribution box (WP 0074 00). Open the cab distribution box to access the relay boards. Remove relay 3018 and test (WP 0113 00). <li data-bbox="735 968 1089 1167">2. Check for continuity. Disconnect connector X174B located in the middle panel. Check for continuity to ground on the loose part of X174B at pin 2. There should not be continuity to ground. <li data-bbox="735 1272 1089 1503">3. Check for continuity. Disconnect connector X47 and connector XK1 located on one of the relay boards. Check for continuity to ground on the loose part of XK1 at pin 8. There should not be continuity to ground. <li data-bbox="735 1545 1089 1629">4. Check ECU (792) pin 60 for connection or damage (WP 0048 00-19). 	<ol style="list-style-type: none"> <li data-bbox="1105 695 1458 789">Replace relay if resistance between terminals 85 and 86 is not 290 to 350 Ohms. <li data-bbox="1105 968 1458 1062">a. If continuity to ground is found, disconnect X47 and recheck. <li data-bbox="1105 1062 1458 1188">b. If continuity to ground is still found, check wire 476 for continuity to ground (WP 0048 00-19). <li data-bbox="1105 1188 1458 1251">c. Replace grounded X174B to X47 cable (WP 0113 00). <li data-bbox="1105 1272 1458 1335">a. If continuity to ground is found, replace wire A476. <li data-bbox="1105 1335 1458 1461">b. If continuity to ground is not found, check wire A174B2 for continuity to ground (WP 0048 00-48). <li data-bbox="1105 1461 1458 1524">c. Replace grounded wire A174B2. <li data-bbox="1105 1545 1458 1608">a. Replace damaged ECU (792) terminal board (WP 0080 00). <li data-bbox="1105 1608 1458 1671">b. Replace ECU (792) (WP 0080 00).

Table 18. Error Code 413 - Boom Folding Supply Valve, Short Circuit Failure Troubleshooting Procedures.

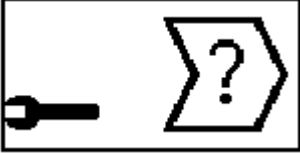
MALFUNCTION	TEST OR INSPECTION	CORRECTIVE ACTION
<p data-bbox="147 432 724 499">Error Code 413 - Boom Folding Supply Valve, Short Circuit Failure.</p> 	<p data-bbox="1045 432 1146 470" style="text-align: center;">NOTE</p> <p data-bbox="777 485 1414 674">Error code 413 is an information type error code. It may not activate for the operator. The operator may report the boom folding system is not working. Enter DIAG STEERING 2(16) in the Diagnostic menu to verify the code or enable the information type codes in the initialization menu.</p> <ol style="list-style-type: none"> <li data-bbox="732 695 1089 974">1. Test for resistance. Open the door to the remote hydraulic compartment. Locate the 6043 boom folding supply valve on the left side wall. Disconnect the connector and check the resistance of the solenoid coil. Resistance should be 40 to 50 Ohms. <li data-bbox="732 995 1089 1274">2. Check for continuity. Disconnect connector X195 located in the middle panel and disconnect the 6043 boom folding supply valve. Check for continuity to ground on the loose part of X195 at pin 8 (WP 0048 00-30). There should not be continuity to ground. <li data-bbox="732 1295 1089 1575">3. Check for continuity. Disconnect connector X198 pin 9 wire GY and disconnect the 6043 boom folding supply valve. Check wire GY for continuity to ground (WP 0048 00-30). There should not be continuity to ground. <li data-bbox="732 1596 1089 1785">4. Check ECU (792) pin 59 for connection or damage (WP 0048 00-30). 	<p data-bbox="1096 695 1458 785">Replace 643 boom folding supply valve if damaged or resistance is not as specified (WP 0263 00).</p> <ol style="list-style-type: none"> <li data-bbox="1096 995 1463 1184">a. If continuity to ground is found, move the cab to the transport position to access X198 under the cover plate. Disconnect X198 pin 9 wire VT and recheck. <li data-bbox="1096 1184 1463 1310">b. If continuity to ground is still found, check wire VT for continuity to ground (WP 0048 00-30). <li data-bbox="1096 1310 1463 1373">c. Replace grounded X195 to X198 cable (WP 0113 00). <li data-bbox="1096 1394 1463 1484">a. If continuity to ground is found, replace wire X198 to 6043 cable (WP 0113 00). <li data-bbox="1096 1484 1463 1610">b. If continuity to ground is not found, check wire A195B for continuity to ground (WP 0048 00-30). <li data-bbox="1096 1610 1463 1673">c. Replace grounded wire A195B. <li data-bbox="1096 1694 1463 1757">a. Replace damaged ECU (792) terminal board (WP 0080 00). <li data-bbox="1096 1757 1463 1820">b. Replace ECU (792) (WP 0080 00).

Table 19. Error Code 415 - Drag Restriction, Short Circuit Failure (RESET or USMC Only) Troubleshooting Procedures.


MALFUNCTION	TEST OR INSPECTION	CORRECTIVE ACTION
<p>Error Code 415 - Drag Restriction, Short Circuit Failure (RESET or USMC Only).</p> 	<ol style="list-style-type: none"> 1. Check continuity. Disconnect X174B located in the middle panel behind the operators seat. Check the diode for continuity of the loose part of X174B between pins 14 and 15. There should be continuity from pin 15 to pin 14 and not from pin 14 to pin 15 (WP 0048 00-13). 2. Check wire A174B15 for continuity to ground. There should not be continuity to ground (WP 0048 00-19). 3. Check ECU (792) pin 57 for connection or damage. 	<p>Replace the diode if continuity is found in both directions.</p> <ol style="list-style-type: none"> a. If continuity to ground is found, replace wire A174B15. b. Repair or replace damaged connector (WP 0113 00). a. Replace damaged ECU (792) terminal board. b. Replace ECU (792) (WP 0080 00).

Table 20. Error Code 416 - Steering Pressure Switch, Circuit Input Error Troubleshooting Procedures.


MALFUNCTION	TEST OR INSPECTION	CORRECTIVE ACTION
<p>Error Code 416 - Steering Pressure Switch, Circuit Input Error.</p> 	<p style="text-align: center;">NOTE</p> <p>Error code 416 is an information type error code. It may not activate for the operator. Enter DIAG STEERING 2(16) in the Diagnostic menu to verify the code or enable the information type codes in the initialization menu. Input error type codes can be activated if the voltage input is not stable due to a bad connection. Error code 340 may be active with this error code.</p> <ol style="list-style-type: none"> 1. Place the cab in the transport position (TM 10-3930-675-10) and remove the hydraulic pump access cover. Inspect the steering pressure switch (245) mounted on the steering valve for damage and connection. 	<p>Replace damaged steering pressure switch (WP 0134 00).</p>

Table 20. Error Code 416 - Steering Pressure Switch, Circuit Input Error Troubleshooting Procedures - Continued.

MALFUNCTION	TEST OR INSPECTION	CORRECTIVE ACTION
<p>Error Code 416 - Steering Pressure Switch, Circuit Input Error - Continued.</p>	<p>2. Check connectors X47, X174, and X197 for connection or damage (ARMY only).</p> <p>3. Check connector X47, X174B, and X197 for connection or damage (RESET or USMC only).</p> <p>4. Check ECU (792) pin 49 for connection or damage (WP 0048 00-18).</p> <p>5. Check wire. Disconnect wire A1974 from ECU (792) and recheck for active 416 error code.</p>	<p>a. Repair or replace damaged connector (WP 0113 00).</p> <p>b. If connectors are found to be in good condition, check wires A473, 473, A1743B, 1973, and 1974 for continuity (WP 0048 00-16 and 18).</p> <p>c. Replace or repair open or damaged wire.</p> <p>a. Repair or replace damaged connector (WP 0113 00).</p> <p>b. If connectors are found to be in good condition, check wires A475, 475, A174B1A, 1973, and 1974 for continuity (WP 0048 00-16 and WP 0048 00-18).</p> <p>c. Replace or repair open or damaged wire.</p> <p>a. Check wire A1974 for continuity (WP 0048 00-18).</p> <p>b. Replace damaged ECU (792) terminal board (WP 0080 00).</p> <p>Replace ECU (792) (WP 0080 00) if error code 416 is still active.</p>

Table 21. Error Code 418 - 2WD Steering Selection Switch, Circuit Input Error Troubleshooting Procedures.


MALFUNCTION	TEST OR INSPECTION	CORRECTIVE ACTION
<p data-bbox="164 443 717 506">Error Code 418 - 2WD Steering Selection Switch, Circuit Input Error.</p> 	<p data-bbox="1045 443 1146 474" style="text-align: center;">NOTE</p> <p data-bbox="784 491 1409 678">Error code 418 is an information type error code. It may not activate for the operator. Enter DIAG STEERING 2(16) in the Diagnostic menu to verify the code or enable the information type codes in the initialization menu. Input error type codes can be activated if the voltage input is not stable due to a bad connection.</p> <ol style="list-style-type: none"> <li data-bbox="737 699 1084 789">1. Inspect the 2WD steering selection switch for damage and connection. <li data-bbox="737 810 1084 903">2. Inspect connectors X177, X160, and X153 for connection or damage. <li data-bbox="737 1062 1084 1155">3. Check ECU (792) pin 47 for connection or damage (WP 0048 00-18). <li data-bbox="737 1205 1084 1325">4. Check wire connection. Disconnect wire A17713 from ECU (792) and recheck for active 418 error code. 	<p data-bbox="1105 699 1453 758">Replace damaged 2WD steering selection switch (WP 0082 00).</p> <ol style="list-style-type: none"> <li data-bbox="1105 810 1453 869">a. Repair or replace damaged connector (WP 0113 00). <li data-bbox="1105 869 1453 982">b. If connectors are found to be in good condition, check wires 15313, A15313, and 16013 (WP 0048 00-18). <li data-bbox="1105 982 1453 1041">c. Replace or repair open or damaged wire. <ol style="list-style-type: none"> <li data-bbox="1105 1062 1453 1121">a. Check wire A17713 for continuity (WP 0048 00-18). <li data-bbox="1105 1121 1453 1180">b. Replace damaged ECU (792) terminal board (WP 0080 00). <p data-bbox="1105 1205 1453 1293">Replace ECU (792) (WP 0080 00) if error code 418 is still active.</p>

Table 22. Error Code 419 - 4WD Steering Selection Switch, Circuit Failure Troubleshooting Procedures.


MALFUNCTION	TEST OR INSPECTION	CORRECTIVE ACTION
<p data-bbox="164 443 717 506">Error Code 419 - 4WD Steering Selection Switch, Circuit Failure.</p> 	<p data-bbox="1049 443 1146 474" style="text-align: center;">NOTE</p> <p data-bbox="784 491 1414 678">Error code 419 is an information type error code. It may not activate for the operator. Enter DIAG STEERING 2(16) in the Diagnostic menu to verify the code or enable the information type codes in the initialization menu. Input error type codes can be activated if the voltage input is not stable due to a bad connection.</p> <ol style="list-style-type: none"> <li data-bbox="737 699 1084 789">1. Inspect the 4WD steering selection switch for damage and connection. <li data-bbox="737 810 1084 903">2. Inspect connectors X177, X160, and X153 for connection or damage. <li data-bbox="737 1113 1084 1205">3. Check ECU (792) pin 46 for connection or damage (WP 0048 00-18). <li data-bbox="737 1255 1084 1377">4. Check wire connection. Disconnect wire A17714 from ECU (792) and recheck for active 419 error code. 	<p data-bbox="1109 699 1455 762">Replace damaged 4WD steering switch (WP 0082 00).</p> <ol style="list-style-type: none"> <li data-bbox="1109 810 1455 873">a. Repair or replace damaged connector (WP 0113 00). <li data-bbox="1109 873 1455 1029">b. If connectors are found to be in good condition, check wires 1529C, 15314, A15314, and 16014 (WP 0048 00-18) for continuity. <li data-bbox="1109 1029 1455 1092">c. Replace or repair open or damaged wire. <li data-bbox="1109 1113 1455 1176">a. Check wire A17714 for continuity (WP 0048 00-18). <li data-bbox="1109 1176 1455 1239">b. Replace damaged ECU (792) terminal board (WP 0080 00). <li data-bbox="1109 1255 1455 1348">c. Replace ECU (792) (WP 0080 00) if error code 419 is still active.

Table 23. Error Code 420 - Crab Steering Selection Switch, Circuit Failure Troubleshooting Procedures.


MALFUNCTION	TEST OR INSPECTION	CORRECTIVE ACTION
<p data-bbox="162 441 714 499">Error Code 420 - Crab Steering Selection Switch, Circuit Failure.</p> 	<p data-bbox="1047 436 1146 468" style="text-align: center;">NOTE</p> <p data-bbox="781 487 1414 674">Error code 420 is an information type error code. It may not activate for the operator. Enter DIAG STEERING 2(16) in the Diagnostic menu to verify the code or enable the information type codes in the initialization menu. Input error type codes can be activated if the voltage input is not stable due to a bad connection.</p> <ol style="list-style-type: none"> <li data-bbox="735 690 1089 779">1. Inspect the crab steering selection switch for damage and connection. <li data-bbox="735 800 1089 888">2. Inspect connectors X177, X160, and X153 for connection or damage. <li data-bbox="735 1098 1089 1186">3. Check ECU (792) pin 45 for connection or damage (WP 0048 00-18). <li data-bbox="735 1241 1089 1360">4. Check wire connection. Disconnect wire A17715 from ECU (792) and recheck for active 420 error code. 	<p data-bbox="1105 690 1442 749">Replace damaged crab steering switch (WP 0082 00).</p> <ol style="list-style-type: none"> <li data-bbox="1105 800 1463 858">a. Repair or replace damaged connector (WP 0113 00). <li data-bbox="1105 863 1463 1016">b. If connectors are found to be in good condition, check wires 1529D, 15315, A15315, and 16015 (WP 0048 00-18) for continuity. <li data-bbox="1105 1020 1463 1079">c. Repair or replace open or damaged wire. <li data-bbox="1105 1098 1463 1157">a. Check wire A17715 for continuity (WP 0048 00-18). <li data-bbox="1105 1161 1463 1220">b. Replace damaged ECU (792) terminal board (WP 0080 00). <p data-bbox="1133 1241 1463 1329">Replace ECU (792) (WP 0080 00) if error code 420 is still active.</p>

Table 24. Error Code 422 - Cab in Transport Proximity Switch, Circuit Input Error Troubleshooting Procedures.


MALFUNCTION	TEST OR INSPECTION	CORRECTIVE ACTION
<p data-bbox="159 438 719 499">Error Code 422 - Cab in Transport Proximity Switch, Circuit Input Error.</p> 	<p data-bbox="1045 438 1146 468" style="text-align: center;">NOTE</p> <p data-bbox="781 487 1414 674">Error code 422 is an information type error code. It may not activate for the operator. Enter DIAG STEERING 2(16) in the Diagnostic menu to verify the code or enable the information type codes in the initialization menu. Input error type codes can be activated if the voltage input is not stable due to a bad connection.</p> <ol style="list-style-type: none"> <li data-bbox="735 690 1089 814">1. Inspect the cab transport proximity switch (7210) located at the right rear of cab for damage. <li data-bbox="735 831 1089 1018">2. Check for proper operation. Place cab in transport position (TM 10-3930-675-10) and check for proper gap and engagement of proximity switch against the frame. <li data-bbox="735 1035 1089 1159">3. Inspect connectors X175, X195, A174, A47, and X174B (RESET or USMC) for connection damage. <li data-bbox="735 1493 1089 1583">4. Check ECU (792) pin 43 for connection or damage (WP 0048 00-30). <li data-bbox="735 1633 1089 1757">5. Check wire connection. Disconnect wire A1752 from ECU (792) and recheck for active 422 error code. 	
	<ol style="list-style-type: none"> <li data-bbox="1105 690 1464 751">a. Replace damaged cab in transport proximity switch (WP 0076 00). <li data-bbox="1105 831 1464 1018">Proximity switch should not extend beyond the end of the protective enclosure. Adjust proximity switch or cab to obtain the proper gap (5 mm) (WP 0076 00 and WP 0138 00). <li data-bbox="1105 1035 1464 1476"> <ol style="list-style-type: none"> <li data-bbox="1105 1035 1464 1096">a. Repair or replace damaged connector (WP 0113 00). <li data-bbox="1105 1100 1464 1413">b. If connectors are found to be in good condition, check wires A1957A, A1957B, (WP 0048 00-30), A1743C, A1743D A174B1B and A174B1C (RESET or USMC) (WP 0048 00-29) and A1743B, A1743C, A174B1A, A475, and 475 (RESET or USMC) (WP 0048 00-18) for continuity. <li data-bbox="1105 1417 1464 1476">c. Replace or repair open or damaged wire. <li data-bbox="1105 1493 1464 1617"> <ol style="list-style-type: none"> <li data-bbox="1105 1493 1464 1554">a. Check wire A1752 for continuity (WP 0048 00-30). <li data-bbox="1105 1558 1464 1617">b. Replace damaged ECU (792) terminal board (WP 0080 00). <li data-bbox="1105 1633 1464 1791"> <ol style="list-style-type: none"> <li data-bbox="1105 1633 1464 1724">a. Replace ECU (792) (WP 0080 00) if error code 422 is still active. <li data-bbox="1105 1728 1464 1791">b. Replace proximity switch (7210) (WP 0076 00). 	

Table 25. Error Code 423 - Ether Start Switch, Circuit Failure Troubleshooting Procedures.

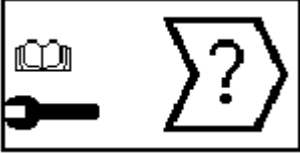
MALFUNCTION	TEST OR INSPECTION	CORRECTIVE ACTION
<p>Error Code 423 - Ether Start Switch, Circuit Failure.</p> 	<p style="text-align: center;">NOTE</p> <p>Error code 423 is an information type error code. It may not activate for the operator. Enter DIAG STEERING 2(16) in the Diagnostic menu to verify the code or enable the information type codes in the initialization menu. Input error type codes can be activated if the voltage input is not stable due to a bad connection.</p> <ol style="list-style-type: none"> 1. Inspect the ether start switch for damage and connection. 2. Inspect connectors X174, X47, and X67 for connection or damage. 3. Check ECU (792) pin 42 for connection or damage (WP 0048 00-18). 4. Check for wire connection. Disconnect wire A17415 from ECU (792) and recheck for active 423 error code. 	<p>Replace damaged ether start switch (WP 0073 00).</p> <ol style="list-style-type: none"> a. Repair or replace damaged connector (WP 0113 00). b. If connectors are found to be in good condition, check wires 674, A479, and d479 (WP 0048 00-47) for continuity. a. Check wire A17415 for continuity (WP 0048 00-18). b. Replace damaged ECU (792) terminal board (WP 0080 00). c. Replace or repair open or damaged wire (WP 0113 00). <p>Replace ECU (792) (WP 0080 00) if error code 423 is still active.</p>

Table 26. Error Code 427 - Tophandler Work Light Switch, Circuit Input Error Troubleshooting Procedures.

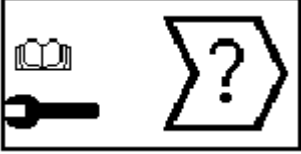
MALFUNCTION	TEST OR INSPECTION	CORRECTIVE ACTION
<p data-bbox="159 434 719 495">Error Code 427 - Tophandler Work Light Switch, Circuit Input Error.</p> 	<p data-bbox="1045 434 1146 464" style="text-align: center;">NOTE</p> <p data-bbox="781 483 1414 667">Error code 427 is an information type error code. It may not activate for the operator. Enter DIAG STEERING 2(16) in the Diagnostic menu to verify the code or enable the information type codes in the initialization menu. Input error type codes can be activated if the voltage input is not stable due to a bad connection.</p> <ol style="list-style-type: none"> <li data-bbox="735 684 1089 772">1. Inspect tophandler work light switch for damage and connection. <li data-bbox="735 791 1089 879">2. Inspect connectors X174, X46, and X67 for connection or damage. <li data-bbox="735 1087 1089 1176">3. Check ECU (792) pin 102 for connection or damage (WP 0048 00-18). <li data-bbox="735 1226 1089 1346">4. Check for wire connection. Disconnect wire A17411 from ECU (792) and recheck for active 427 error code. 	<p data-bbox="1105 684 1458 745">Replace damaged tophandler work light switch (WP 0073 00).</p> <ol style="list-style-type: none"> <li data-bbox="1105 791 1458 852">a. Repair or replace damaged connector (WP 0113 00). <li data-bbox="1105 856 1458 1010">b. If connectors are found to be in good condition, check wires 679, A466 (WP 0048 00-46), and 466 (WP 0048 00-18) for continuity. <li data-bbox="1105 1014 1458 1075">c. Replace or repair open or damaged wire (WP 0113 00). <ol style="list-style-type: none"> <li data-bbox="1105 1087 1458 1148">a. Check wire A17411 for continuity (WP 0048 00-18). <li data-bbox="1105 1152 1458 1213">b. Replace damaged ECU (792) terminal board (WP 0080 00). <p data-bbox="1133 1226 1458 1314">Replace ECU (792) (WP 0080 00) if error code 427 is still active.</p>

Table 27. Error Code 440 - Steering Wheel Sensor, Power Supply Error (RESET or USMC Only) Troubleshooting Procedures.

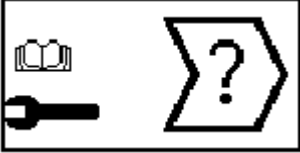

MALFUNCTION	TEST OR INSPECTION	CORRECTIVE ACTION
<p data-bbox="162 443 719 506">Error Code 440 - Steering Wheel Sensor, Power Supply Error (RESET or USMC Only).</p> 	<p data-bbox="1045 443 1146 474" style="text-align: center;">NOTE</p> <p data-bbox="781 489 1414 705">Error code 440 is an information type error code. It may not activate for the operator. The operator may report the steering wheel has no resistance and does not stop at the full turning radius. Enter DIAG STEERING 2(16) in the Diagnostic menu to verify the code or enable the information type codes in the initialization menu.</p> <ol style="list-style-type: none"> <li data-bbox="735 730 1089 852">1. Inspect the steering wheel sensor and connector cable located at the bottom of the steering column for damage. <li data-bbox="735 873 1089 1150">2. Disconnect the connector from the steering wheel sensor and connector X176 located in the middle panel behind the operator's seat. Check each wire in the cable for continuity, continuity to ground, and for continuity between each wire (WP 0048 00-17). <li data-bbox="735 1171 1089 1419">3. Check for continuity to ground or continuity between each wire on the mounted part of connector X176 for pins 1 through 8 (WP 0048 00-17). There should not be continuity to ground or continuity between wires. <li data-bbox="735 1440 1089 1562">4. Check ECU (792) pins, 23, 40, 113, 96, 41, 38, 132, 97, and 56 for connection or damage (WP 0048 00-17). 	<p data-bbox="1105 730 1458 821">Replace damaged steering wheel sensor or connector cable (WP 0136 00).</p> <p data-bbox="1105 873 1458 963">Replace damaged, grounded, or shorted steering wheel sensor to X176 cable (WP 0136 00).</p> <ol style="list-style-type: none"> <li data-bbox="1105 1171 1463 1234">a. Replace any grounded or shorted wire(s). <li data-bbox="1105 1234 1463 1297">b. Repair or replace damaged connector (WP 0113 00). <li data-bbox="1105 1440 1463 1503">a. Replace damaged ECU (792) terminal board (WP 0080 00). <li data-bbox="1105 1503 1463 1566">b. Replace ECU (792) (WP 0080 00).

Table 28. Error Code 450 - Temperature Inside Steering ECU (792) Above Critical Threshold [184°F (85°C)] Troubleshooting Procedures.

MALFUNCTION	TEST OR INSPECTION	CORRECTIVE ACTION
<p>Error Code 450 - Temperature Inside Steering ECU (792) Above Critical Threshold [184°F (85°C)].</p> 	<ol style="list-style-type: none"> 1. Check if temperature at steering ECU (792) is extremely high. 2. Place ignition switch in OFF position for a minimum of 30 seconds, and then back in ON position. 	<p>If temperature is extremely high, allow ECU to cool down.</p> <p>Replace steering ECU (792) if error code is still present (WP 0080 00).</p>

END OF WORK PACKAGE

THIS WORK PACKAGE COVERS

Error Code 1187 - Sensor Voltage Supply Failure
 Error Code 1227 - Sensor Voltage Supply Failure
 Error Code 1287 - Sensor Voltage Supply Failure

Error Code 1352 - Sensor Voltage Supply Failure
 Error Code 1443 - Low Voltage Detected at Throttle
 Position Sensor Circuit

INITIAL SETUP

Tools and Special Tools

Test Lead, Female (Item 121, WP 0289 00)
 Test Lead, Male (Item 124, WP 0289 00)

References

TM 10-3930-675-10

NOTE

- Refer to WP 0004 00 for additional troubleshooting guidance, information, and illustrations that locate critical components.
- Refer also to illustrations at end of work package for component location.

Table 1. Error Code 1187 - Sensor Voltage Supply Failure Troubleshooting Procedures.


MALFUNCTION	TEST OR INSPECTION	CORRECTIVE ACTION
<p>Error Code 1187 - Sensor Voltage Supply Failure.</p> 	<ol style="list-style-type: none"> 1. Disconnect sensor harness from oil pressure/temperature sensor (WP 0094 00). 2. Place ignition switch in ON position. 	

Table 1. Error Code 1187 - Sensor Voltage Supply Failure Troubleshooting Procedures - Continued.

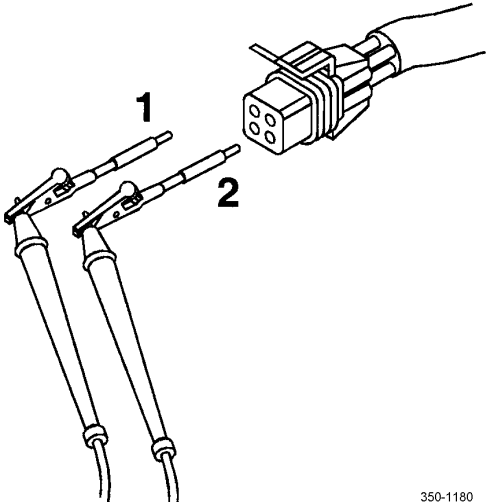
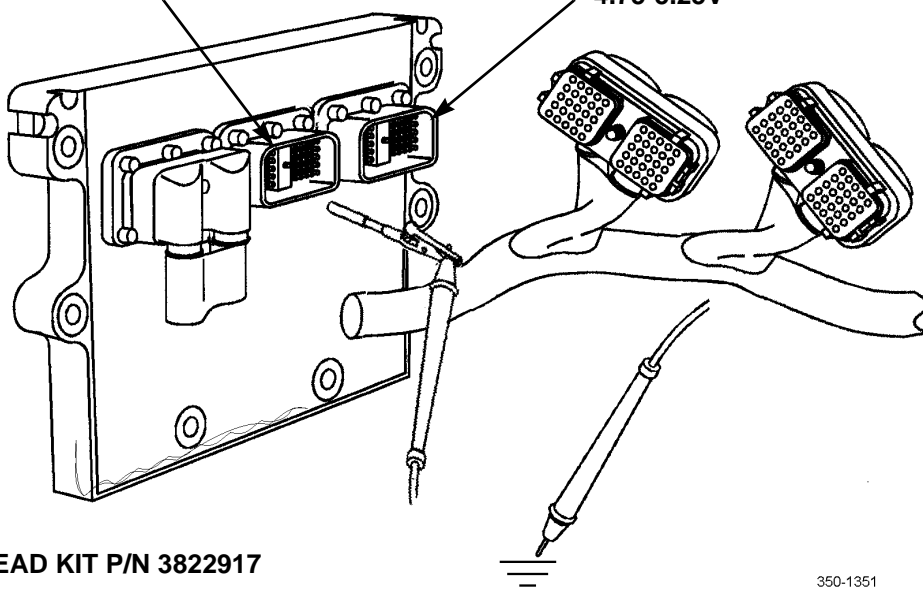
MALFUNCTION	TEST OR INSPECTION	CORRECTIVE ACTION
<p>Error Code 1187 - Sensor Voltage Supply Failure - Continued.</p>	<p>3. Measure voltage from oil pressure/temperature sensor connector pin A to pin B. Voltage should be less than 4.5V.</p>  <p style="text-align: right;"><4.5V USE TEST LEAD KIT P/N 3822758</p> <p style="text-align: center; font-size: small;">350-1180</p> <p>4. Place ignition switch in OFF position and disconnect sensor harness connector from engine ECU.</p> <p>a. Inspect engine harness and sensor connector for dirty, corroded, bent, broken, pushed back, and extended pins.</p> <p>b. Check engine harness and engine ECU connector for dirt or moisture in or on connector and for missing or damaged connector seals.</p>	<p>If voltage is not as specified, replace oil pressure/temperature sensor (WP 0094 00).</p> <p>Clean and repair connector(s) as required (WP 0113 00).</p> <p>Remove dirt and moisture from connector. Replace missing or damaged connector seals (WP 0113 00).</p>

Table 1. Error Code 1187 - Sensor Voltage Supply Failure Troubleshooting Procedures - Continued.

MALFUNCTION	TEST OR INSPECTION	CORRECTIVE ACTION
<p>Error Code 1187 - Sensor Voltage Supply Failure - Continued.</p>	<p>5. Disconnect sensor harness and actuator harness from engine ECU. Place ignition switch to ON position.</p> <p>a. Measure voltage between engine ECU sensor port pin 18, pin 25, pin 45, and ground. Voltage should be 4.75 to 5.25V.</p> <p>b. Measure voltage between engine ECU actuator port pin 19 and pin 29 and ground. Voltage should be 4.75 to 5.25V.</p>	<p>If voltage is not as specified, replace engine ECU (WP 0079 00).</p> <p>If voltage is not as specified, replace engine ECU (WP 0079 00).</p>

**ACTUATOR PORT:
PINS 19 AND 29 TO ENGINE
BLOCK GROUND
4.75-5.25V**

**SENSOR PORT:
PINS 18,25,45 TO ENGINE
BLOCK GROUND
4.75-5.25V**



USE TEST LEAD KIT P/N 3822917

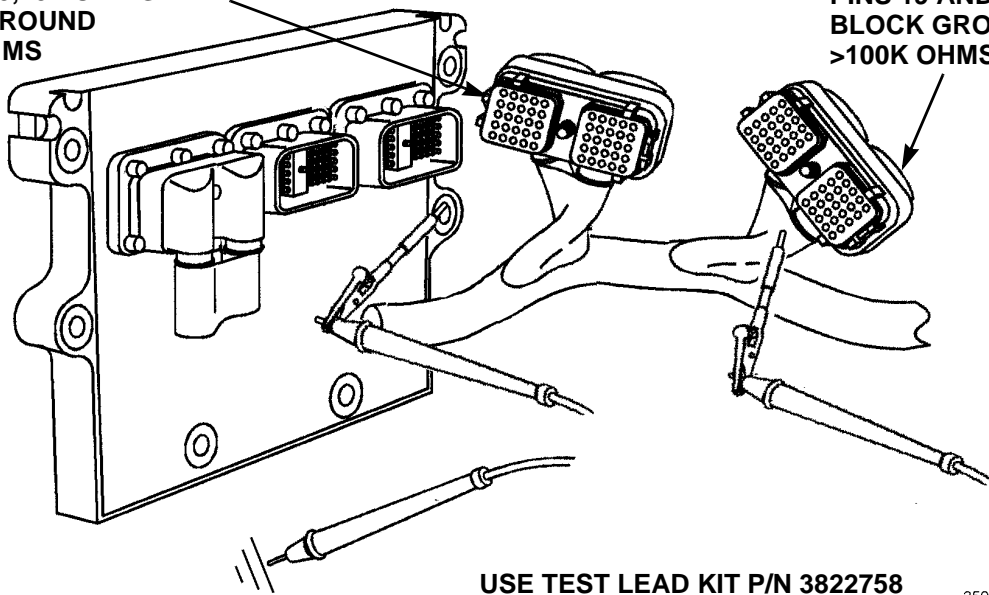
350-1351

Table 1. Error Code 1187 - Sensor Voltage Supply Failure Troubleshooting Procedures - Continued.

MALFUNCTION	TEST OR INSPECTION	CORRECTIVE ACTION
<p>Error Code 1187 - Sensor Voltage Supply Failure - Continued.</p>	<p>6. Place ignition switch in OFF position. Disconnect sensor harness and actuator harness from engine ECU.</p> <p>a. Measure resistance from sensor harness connector pins 18, 25, and 45 to engine block ground. Resistance should be greater than 100k Ohms.</p> <p>b. Measure resistance from actuator harness connector pins 19 and 29 to engine block ground. Resistance should be greater than 100k Ohms.</p>	<p>If engine harness requires replacement, notify Sustainment Maintenance.</p> <p>If engine harness requires replacement, notify Sustainment Maintenance.</p>

**SENSOR HARNESS:
PINS 18,25,45 TO ENGINE
BLOCK GROUND
>100K OHMS**

**ACTUATOR HARNESS:
PINS 19 AND 29 TO ENGINE
BLOCK GROUND
>100K OHMS**



USE TEST LEAD KIT P/N 3822758

350-1352

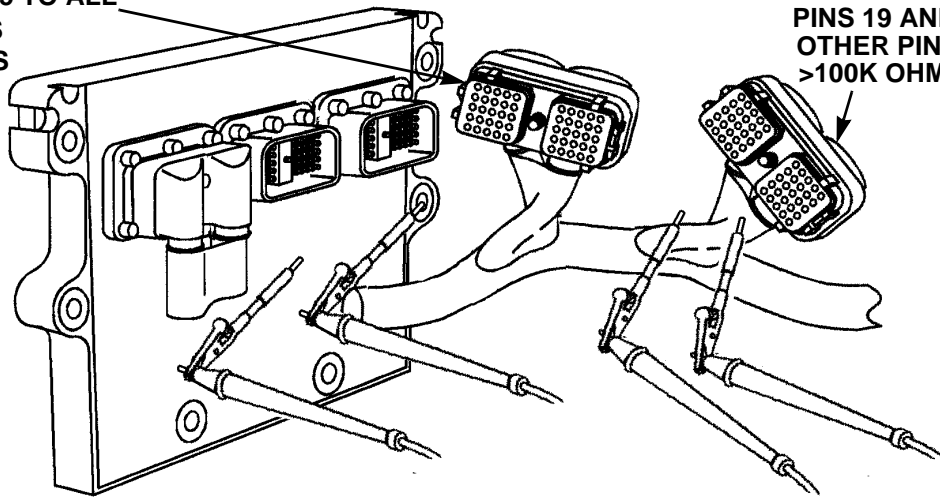
<p>7. Place ignition switch in OFF position. Disconnect sensor harness and actuator harness from engine ECU. Disconnect oil pressure/temperature sensor and coolant level sensor jumpers.</p>

Table 1. Error Code 1187 - Sensor Voltage Supply Failure Troubleshooting Procedures - Continued.

MALFUNCTION	TEST OR INSPECTION	CORRECTIVE ACTION
<p>Error Code 1187 - Sensor Voltage Supply Failure - Continued.</p>	<p>a. Measure resistance from sensor harness connector pin 18 to all other pins in connector. Resistance should be more than 100k Ohms.</p> <p>b. Measure resistance from sensor harness connector pin 25 to all other pins in connector. Resistance should be more than 100k Ohms.</p> <p>c. Measure resistance from sensor harness connector pin 45 to all other pins in connector. Resistance should be more than 100k Ohms.</p> <p>d. Measure resistance from actuator harness connector pin 19 to all other pins in connector. Resistance should be more than 100k Ohms.</p> <p>e. Measure resistance from actuator harness connector pin 29 to all other pins in connector. Resistance should be more than 100k Ohms.</p>	<p>If engine harness requires replacement, notify Sustainment Maintenance.</p> <p>If engine harness requires replacement, notify Sustainment Maintenance.</p> <p>If engine harness requires replacement, notify Sustainment Maintenance.</p> <p>If engine harness requires replacement, notify Sustainment Maintenance.</p> <p>If engine harness requires replacement, notify Sustainment Maintenance.</p>

**SENSOR HARNESS:
PINS 18,25,45 TO ALL
OTHER PINS
>100K OHMS**

**ACTUATOR HARNESS:
PINS 19 AND 29 TO ALL
OTHER PINS
>100K OHMS**



USE TEST LEAD KIT P/N 3822758

350-1353

Table 2. Error Code 1227 - Sensor Voltage Supply Failure Troubleshooting Procedures.

MALFUNCTION	TEST OR INSPECTION	CORRECTIVE ACTION
<p>Error Code 1227 - Sensor Voltage Supply Failure.</p>	<ol style="list-style-type: none"> 1. Place ignition switch in OFF position and disconnect sensor harness connector from engine ECU. <ol style="list-style-type: none"> a. Inspect engine harness and sensor connector for dirty, corroded, bent, broken, pushed back, and extended pins. b. Check engine harness and engine ECU connector for dirt or moisture in or on connector and for missing or damaged connector seals. 2. Disconnect sensor harness and actuator harness from engine ECU. Place ignition switch to ON position. <ol style="list-style-type: none"> a. Measure supply voltage out of engine ECU sensor port at pins 18, 25, and 45 to ground. Voltage should be 4.75 to 5.25V. 	<p>Clean and repair connector(s) as required (WP 0113 00).</p> <p>Remove dirt and moisture from connector. Replace missing or damaged connector seals (WP 0113 00).</p> <p>If voltage is not as specified, replace engine ECU (WP 0079 00).</p>

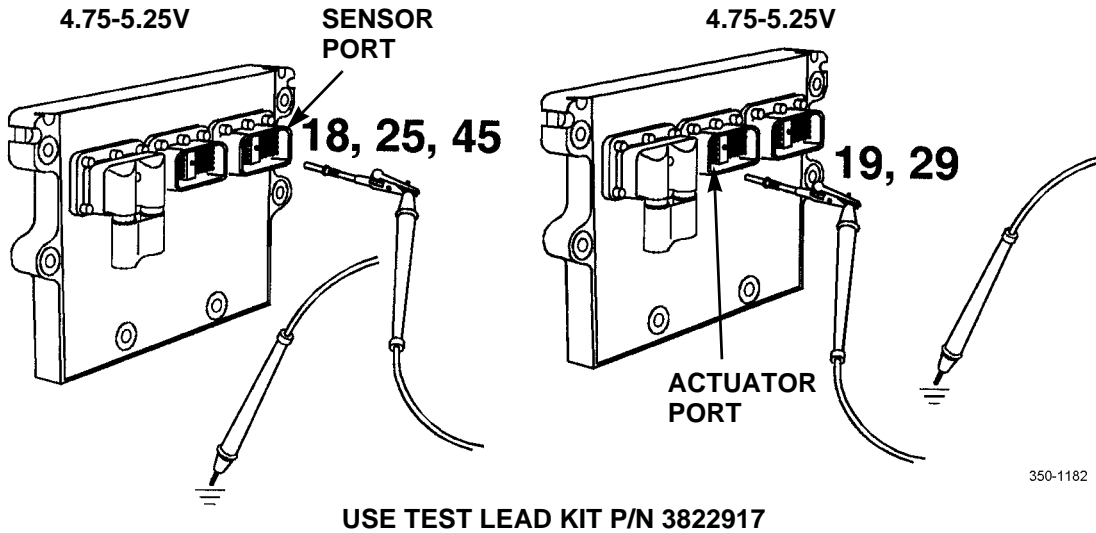


Table 2. Error Code 1227 - Sensor Voltage Supply Failure Troubleshooting Procedures - Continued.

MALFUNCTION	TEST OR INSPECTION	CORRECTIVE ACTION
<p>Error Code 1227 - Sensor Voltage Supply Failure - Continued.</p>	<p>b. Measure supply voltage out of engine ECU actuator port at pins 19 and 29 to ground. Voltage should be 4.75 to 5.25V.</p> <p>3. Place ignition switch in OFF position and disconnect sensor harness from engine ECU.</p> <p>a. Measure resistance from sensor harness connector pin 18 to all sensor harness connector pins. Resistance should be greater than 100k Ohms.</p> <p>b. Measure resistance from sensor harness connector pin 25 to all sensor harness connector pins. Resistance should be greater than 100k Ohms.</p> <p>c. Measure resistance from sensor harness connector pin 45 to all sensor harness connector pins. Resistance should be greater than 100k Ohms.</p>	<p>If voltage is not as specified, replace engine ECU (WP 0079 00).</p> <p>If engine harness requires replacement, notify Sustainment Maintenance.</p> <p>If engine harness requires replacement, notify Sustainment Maintenance.</p> <p>If engine harness requires replacement, notify Sustainment Maintenance.</p>

USE TEST LEAD
KIT P/N 3822758

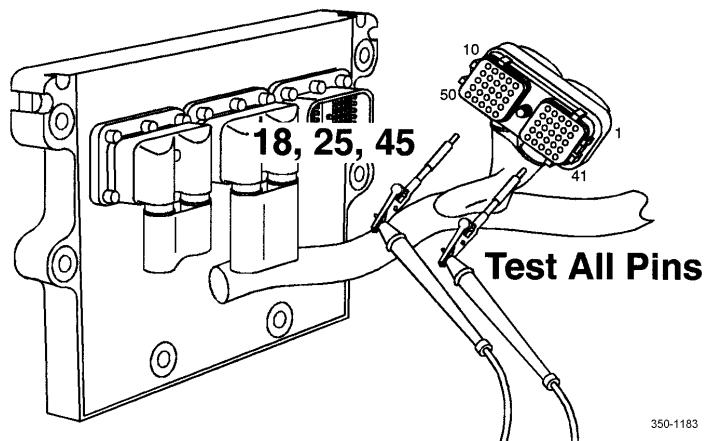
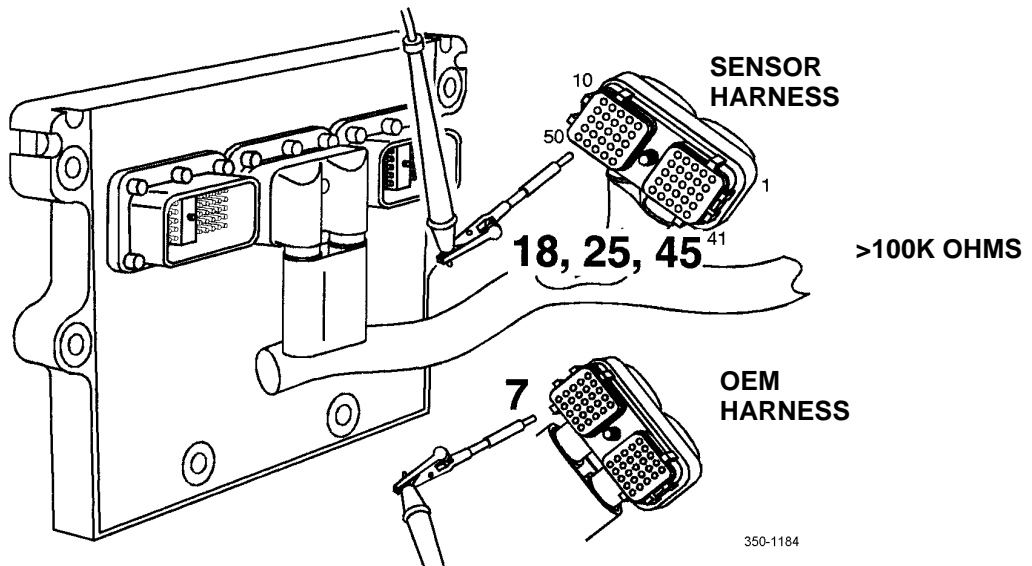


Table 2. Error Code 1227 - Sensor Voltage Supply Failure Troubleshooting Procedures - Continued.

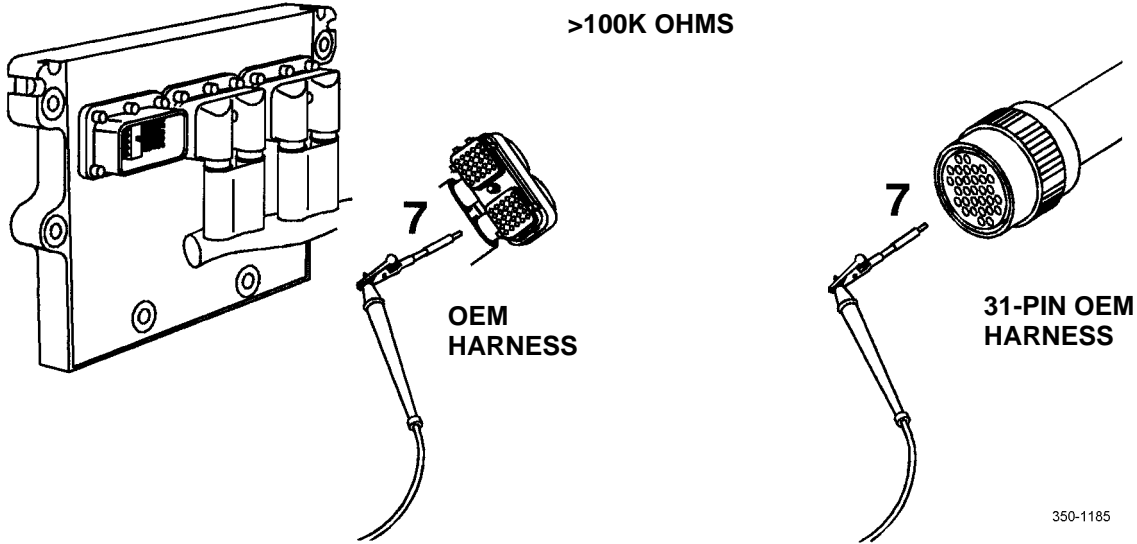
MALFUNCTION	TEST OR INSPECTION	CORRECTIVE ACTION
<p>Error Code 1227 - Sensor Voltage Supply Failure - Continued.</p>	<p>4. Place ignition switch in OFF position and disconnect sensor harness and OEM harness connector from engine ECU.</p> <p>a. Measure resistance from sensor harness connector pin 18 to pin 7 of OEM harness connector. Resistance should be greater than 100k Ohms.</p> <p>b. Measure resistance from sensor harness connector pin 25 to pin 7 of OEM harness connector. Resistance should be greater than 100k Ohms.</p> <p>c. Measure resistance from sensor harness connector pin 45 to pin 7 of OEM harness connector. Resistance should be greater than 100k Ohms.</p>	<p>If engine harness requires replacement, notify Sustainment Maintenance.</p> <p>If engine harness requires replacement, notify Sustainment Maintenance.</p> <p>If engine harness requires replacement, notify Sustainment Maintenance.</p>

USE TEST LEAD KIT P/N 3822758



350-1184

Table 2. Error Code 1227 - Sensor Voltage Supply Failure Troubleshooting Procedures - Continued.

MALFUNCTION	TEST OR INSPECTION	CORRECTIVE ACTION
<p>Error Code 1227 - Sensor Voltage Supply Failure - Continued.</p> 	<p>5. If resistance was not as specified in step 4, turn ignition switch to OFF position and disconnect 31-pin OEM harness connector (round) and OEM harness from engine ECU.</p> <p>Measure resistance from 31-pin OEM harness connector pin 7 to OEM harness connector pin 7. Resistance should be greater than 100k Ohms.</p>	<p>If engine harness requires replacement, notify Sustainment Maintenance.</p>

350-1185

Table 2. Error Code 1227 - Sensor Voltage Supply Failure Troubleshooting Procedures - Continued.

MALFUNCTION	TEST OR INSPECTION	CORRECTIVE ACTION
<p>Error Code 1227 - Sensor Voltage Supply Failure - Continued.</p>	<p>6. Place ignition switch in OFF position and disconnect actuator harness connector from engine ECU.</p> <p>a. Inspect engine ECU and actuator harness connector for dirty, corroded, bent, broken, pushed back, and extended pins.</p> <p>b. Check engine ECU and actuator harness connector for dirt or moisture in or on connector and for missing or damaged connector seals.</p> <p>7. Place ignition switch in OFF position and disconnect sensor harness from engine ECU.</p> <p>a. Measure resistance from actuator harness pin 19 to all other pins in actuator harness. Resistance should be greater than 100k Ohms.</p>	<p>Clean and repair connector(s) as required (WP 0113 00).</p> <p>Remove dirt and moisture from connector. Replace missing or damaged connector seals (WP 0113 00).</p> <p>If engine harness requires replacement, notify Sustainment Maintenance.</p>

USE TEST LEAD KIT P/N 3822758

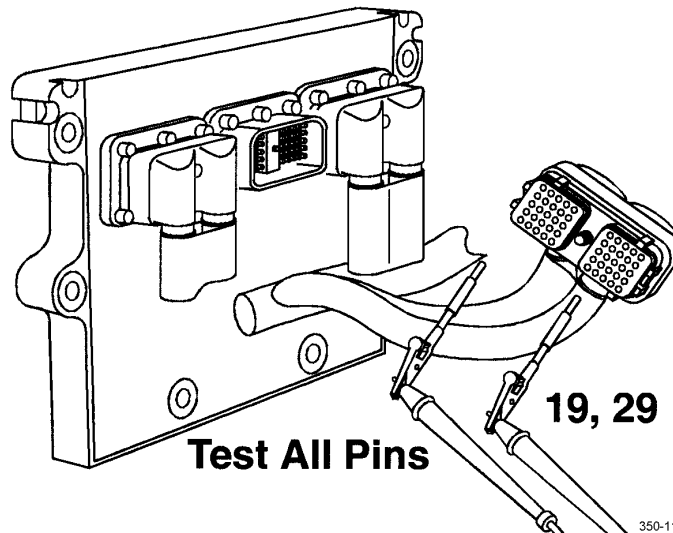


Table 2. Error Code 1227 - Sensor Voltage Supply Failure Troubleshooting Procedures - Continued.

MALFUNCTION	TEST OR INSPECTION	CORRECTIVE ACTION
<p>Error Code 1227 - Sensor Voltage Supply Failure - Continued.</p>	<p>b. Measure resistance from actuator harness pin 29 to all other pins in actuator harness. Resistance should be greater than 100k Ohms.</p> <p>8. Place ignition switch in OFF position and disconnect actuator harness and OEM harness from engine ECU.</p> <p>a. Measure resistance from actuator harness connector pin 19 to OEM harness connector pin 7. Resistance should be greater than 100k Ohms.</p> <p>b. Measure resistance from actuator harness connector pin 29 to OEM harness connector pin 7. Resistance should be greater than 100k Ohms.</p>	<p>If engine harness requires replacement, notify Sustainment Maintenance.</p> <p>If engine harness requires replacement, notify Sustainment Maintenance.</p> <p>If engine harness requires replacement, notify Sustainment Maintenance.</p>

USE TEST LEAD
KIT P/N 3822758

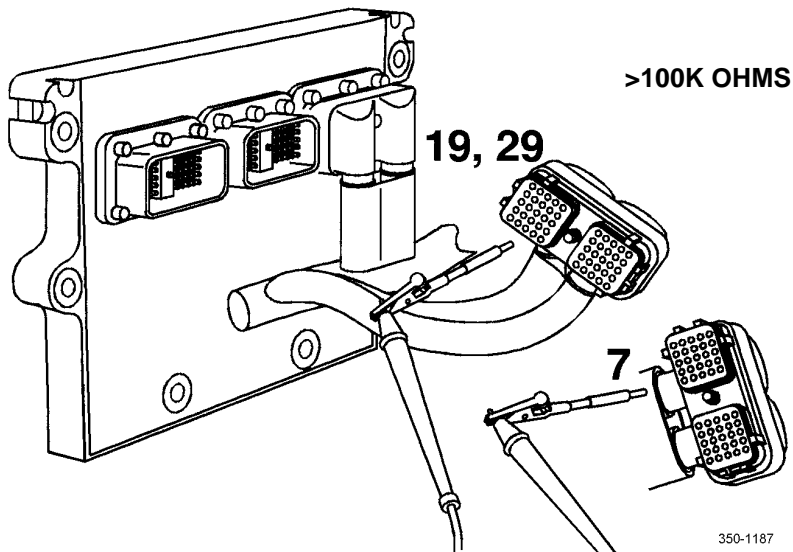


Table 2. Error Code 1227 - Sensor Voltage Supply Failure Troubleshooting Procedures - Continued.

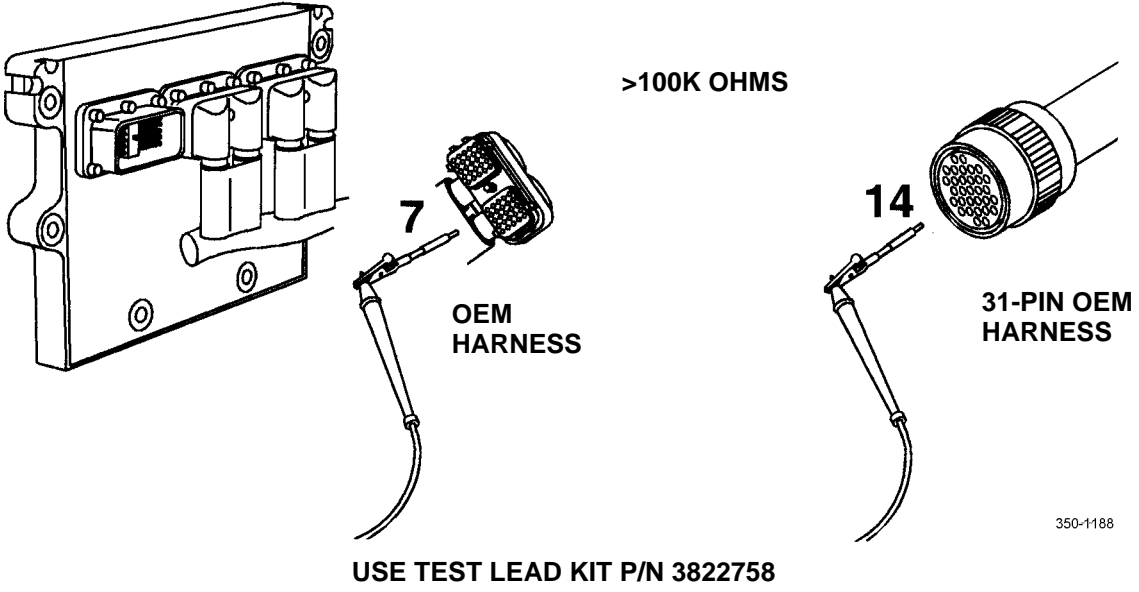
MALFUNCTION	TEST OR INSPECTION	CORRECTIVE ACTION
<p>Error Code 1227 - Sensor Voltage Supply Failure - Continued.</p>  <p style="text-align: center;">>100K OHMS</p> <p style="text-align: center;">USE TEST LEAD KIT P/N 3822758</p>	<p>9. Turn ignition key to OFF position and disconnect 31-pin OEM (round) harness connector and OEM harness from engine ECU.</p> <p>Measure resistance from 31-pin OEM harness connector pin 7 to OEM harness connector pin 14. Resistance should be greater than 100k Ohms.</p>	<p>If engine harness requires replacement, notify Sustainment Maintenance.</p>

Table 3. Error Code 1287 - Sensor Voltage Supply Failure Troubleshooting Procedures.


MALFUNCTION	TEST OR INSPECTION	CORRECTIVE ACTION
<p>Error Code 1287 - Sensor Voltage Supply Failure.</p> 	<p>Perform Troubleshooting Procedures for error codes: 1131, 1132, 1551, 1431, 1432, and 1443.</p>	<p>Notify Sustainment Maintenance.</p>

Table 4. Error Code 1352 - Sensor Voltage Supply Failure Troubleshooting Procedures.

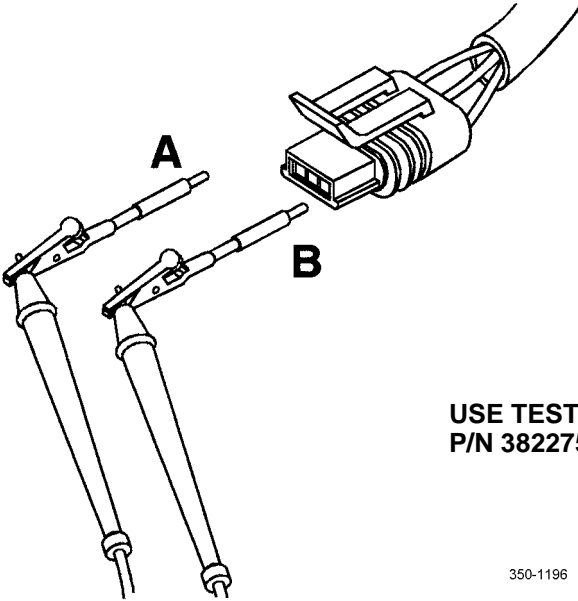
MALFUNCTION	TEST OR INSPECTION	CORRECTIVE ACTION
	<p>1. Disconnect sensor harness from intake manifold pressure sensor and place ignition switch in ON position.</p> <p>2. Measure voltage from intake manifold pressure connector pin A to pin B. Voltage should be less than 4.5V.</p>  <p>USE TEST LEAD KIT P/N 3822758</p> <p>350-1196</p>	<p>If voltage is not as specified, replace intake manifold pressure sensor (WP 0094 00).</p>

Table 4. Error Code 1352 - Sensor Voltage Supply Failure Troubleshooting Procedures - Continued.

MALFUNCTION	TEST OR INSPECTION	CORRECTIVE ACTION
<p>Error Code 1352 - Sensor Voltage Supply Failure - Continued.</p>	<ol style="list-style-type: none"> 3. Disconnect sensor harness from ambient air pressure sensor and place ignition switch in ON position. 4. Measure voltage from ambient air pressure connector pin A to pin B. Voltage should be less than 4.5V. 5. Place ignition switch in OFF position and disconnect sensor harness from engine ECU. <ol style="list-style-type: none"> a. Inspect engine ECU and sensor harness connector for dirty, corroded, bent, broken, pushed back, and extended pins. 	<p>If voltage is not as specified, replace ambient air pressure sensor (WP 0094 00).</p> <p>Clean and repair connector(s) as required (WP 0113 00).</p>

Table 4. Error Code 1352 - Sensor Voltage Supply Failure Troubleshooting Procedures - Continued.

MALFUNCTION	TEST OR INSPECTION	CORRECTIVE ACTION
<p>Error Code 1352 - Sensor Voltage Supply Failure - Continued.</p>	<p>b. Check engine ECU and sensor harness connector for dirt or moisture in or on connector and for missing or damaged connector seals.</p> <p>6. Disconnect sensor harness from engine ECU and place ignition switch in ON position.</p> <p>7. Measure voltage from engine ECU connector pins 17 and 37 to ground. Voltage should be 4.75 to 5.25V.</p>	<p>Remove dirt and moisture from connector. Replace missing or damaged connector seals (WP 0113 00).</p> <p>If voltage is not as specified, replace engine ECU (WP 0079 00).</p>
<p>8. Place ignition switch in OFF position and disconnect sensor harness from engine ECU, ambient air pressure sensor, and intake manifold pressure sensor.</p> <p>9. Measure resistance from sensor harness pins 17 and 37 to engine block ground. Resistance should be greater than 100k Ohms.</p> <p>If engine harness requires replacement, notify Sustainment Maintenance.</p>		

Table 4. Error Code 1352 - Sensor Voltage Supply Failure Troubleshooting Procedures - Continued.

MALFUNCTION	TEST OR INSPECTION	CORRECTIVE ACTION
<p>Error Code 1352 - Sensor Voltage Supply Failure - Continued.</p>	<p>10. Place ignition switch in OFF position and disconnect sensor harness from engine ECU, ambient air pressure sensor, and intake manifold pressure sensor.</p> <p>a. Measure resistance from sensor harness pin 17 to all other pins in sensor harness. Resistance should be greater than 100k Ohms.</p> <p>b. Measure resistance from sensor harness pin 37 to all other pins in sensor harness. Resistance should be greater than 100k Ohms.</p>	<p>If engine harness requires replacement, notify Sustainment Maintenance.</p> <p>If engine harness requires replacement, notify Sustainment Maintenance.</p>

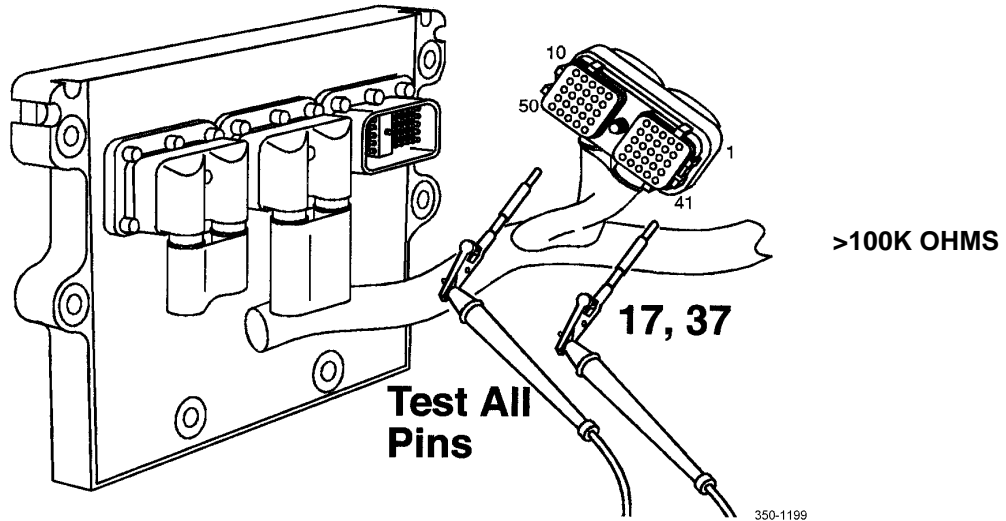


Table 5. Error Code 1443 - Low Voltage Detected at Throttle Position Sensor Circuit Troubleshooting Procedures.

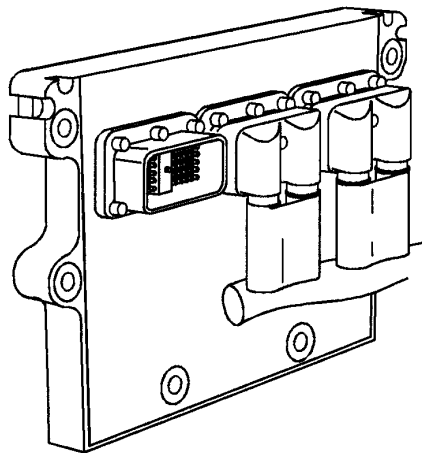
MALFUNCTION	TEST OR INSPECTION	CORRECTIVE ACTION
<p>Error Code 1443 - Low Voltage Detected at Throttle Position Sensor Circuit.</p>	<p style="text-align: center;">NOTE</p> <p>Use test lead, female - part number 3823994 (Item 122, WP 0289 00-21) to test connector X690. Use test lead, male - part number 3822758 (Item 124, WP 0289 00-21) to test the OEM harness connector.</p> <ol style="list-style-type: none"> 1. Inspect the accelerator pedal assembly for damage and wiring harness connection (WP 0062 00). 2. Check connector. Access the cab distribution box in the panel behind the operator's seat. Pull the box out and disconnect connector X23. 3. Inspect connector X23 for damage. Check resistance on the loose part of connector X23 between pins 4 and 5. Resistance should be 2,000 to 3,000 Ohms (WP 0048 00-11). 4. Check continuity on the loose part of connector X23 between pin 3 and ground and pin 4 and ground. There should not be continuity to ground (WP 0048 00-11). 5. Check connector wiring harness. Remove the kick panel from in front of the steering column to access the X690 connector on the accelerator pedal wiring harness. 	<p>Replace damaged accelerator pedal or connect disconnected wiring harness (WP 0062 00).</p> <ol style="list-style-type: none"> a. If resistance is not as specified, continue with step 4. b. Repair or replace damaged connector (WP 0113 00). <p>If continuity to ground is found, continue with step 5.</p>

Table 5. Error Code 1443 - Low Voltage Detected at Throttle Position Sensor Circuit Troubleshooting Procedures - Continued.

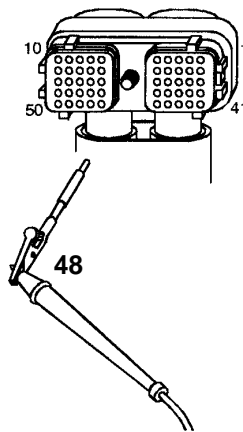
MALFUNCTION	TEST OR INSPECTION	CORRECTIVE ACTION
<p>Error Code 1443 - Low Voltage Detected at Throttle Position Sensor Circuit - Continued.</p>	<p>6. Check for resistance. Disconnect connector X690 and inspect for damage. Check resistance on the accelerator pedal part of connector X690 between pins 4 and 5. Check each pin for continuity to ground. There should be a resistance of 2,000 to 3,000 Ohms and no continuity to ground (WP 0048 00-11).</p> <p>7. Check continuity of the accelerator pedal part of connector X690 between pin 5 and ground and pin 6 and ground. There should not be continuity to ground (WP 0048 00-11).</p> <p>8. Remove the engine cover (WP 0148 00). Disconnect the OEM harness connector from ECU (794) (WP 0080 00). Inspect the OEM harness connector and ECU pins for damage, dirt, or corrosion.</p> <p>9. Inspect connector X16 for damage. Disconnect connector X16. Turn the ignition ON and check for voltage at connector X16 between pin 4 and ground (WP 0048 00-11). Voltage should be 4.75V to 5.25V at each pin.</p>	<p>a. If resistance is not as specified, replace accelerator pedal assembly (WP 0062 00).</p> <p>b. Repair or replace damaged connector (WP 0113 00).</p> <p>a. If continuity to ground is found, replace accelerator pedal assembly (WP 0062 00).</p> <p>b. If continuity to ground is not found, check continuity and for continuity to ground for wires 233, 234, and 235 (WP 0048 00-11).</p> <p>c. Repair or replace damaged connector (WP 0113 00).</p> <p>d. Replace damaged, open, shorted, or grounded X690 to X23 wiring harness (WP 0113 00).</p> <p>a. Clean and repair connector as required (WP 0113 00).</p> <p>b. Replace damaged ECU (794) (WP 0080 00).</p> <p>a. If voltage (4.75V to 5.25V) is not as specified, continue with step 10.</p> <p>b. Repair or replace damaged connector (WP 0113 00).</p>

Table 5. Error Code 1443 - Low Voltage Detected at Throttle Position Sensor Circuit Troubleshooting Procedures - Continued.

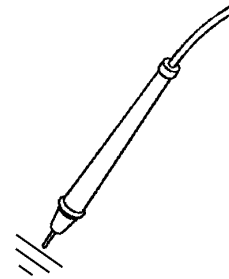
MALFUNCTION	TEST OR INSPECTION	CORRECTIVE ACTION
<p>Error Code 1443 - Low Voltage Detected at Throttle Position Sensor Circuit - Continued.</p>	<p>10. Check continuity. Disconnect connector X16 and the OEM harness connector. Check continuity and for continuity to ground for wires 163, 164, and 165 (WP 0048 00-11).</p> <p>11. Check continuity. Disconnect connector X16. Check continuity and for continuity to ground for wires A163, A164, and A165 (WP 0048 00-11).</p> <p>12. Check continuity. Disconnect the OEM harness connector and connector X16. Check for continuity on the OEM harness connector between pin 48 and ground and between pin 48 and pin 49. There should not be continuity between pins.</p>	<p>If continuity to ground is found at any one wire or any wire is found to be open, notify Sustainment Maintenance to replace engine and transmission wiring harness (WP 0113 00).</p> <p>Replace any damaged, open, or grounded wires.</p> <p>If continuity is found between pin 48 and ground or continuity between pin 48 and pin 49, notify Sustainment Maintenance to replace the engine and transmission wiring harness (WP 0113 00).</p>



USE TEST LEAD
KIT P/N 3822758



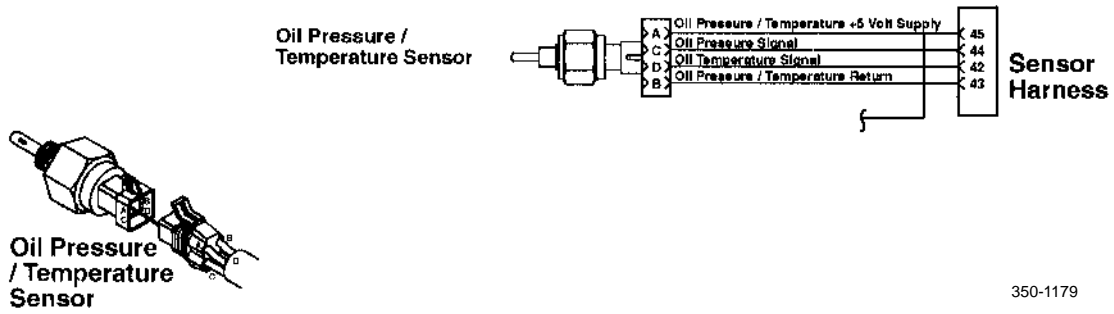
>100K OHMS



350-1356

NOTE

The RTCH does not have a coolant level or oil level sensor.



END OF WORK PACKAGE

ENGINE POSITION SENSOR CIRCUITS TROUBLESHOOTING

0019 00

THIS WORK PACKAGE COVERS

Error Code 1115 - Engine Position Sensor Circuit Failure

Error Code 1234 - Engine Overspeed Failure

Error Code 1121 - Engine Position Sensor Circuit Failure

INITIAL SETUP

Tools and Special Tools

Test Lead, Female (Item 123, WP 0289 00)

Test Lead, Male (Item 124, WP 0289 00)

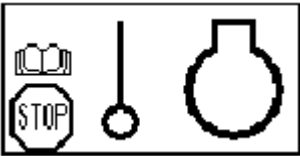
References

TM 10-3930-675-10

NOTE

- Refer to WP 0004 00 for additional troubleshooting guidance, information, and illustrations that locate critical components.
- Refer also to illustration at end of work package for component location.

Table 1. Error Code 1115 - Engine Position Sensor Circuit Failure Troubleshooting Procedures.

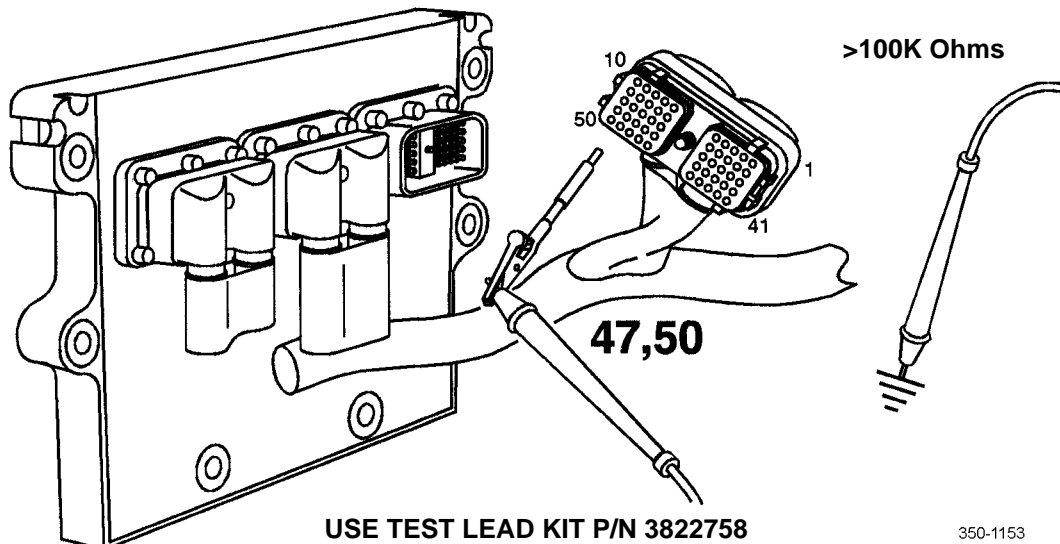
MALFUNCTION	TEST OR INSPECTION	CORRECTIVE ACTION
<p>Error Code 1115 - Engine Position Sensor Circuit Failure.</p> 	<ol style="list-style-type: none"> 1. Ensure ignition switch is in OFF position. Disconnect engine harness from engine position sensor (WP 0094 00). 2. Inspect engine harness and engine position sensor connectors for dirty, corroded, bent, broken, and pushed back or extended pins. 3. Check engine harness and engine position sensor for dirt or moisture in or on connectors and for missing or damaged connector seals. 4. Check for short circuit to ground: 	<p>Clean and repair connector(s) as required (WP 0113 00).</p> <p>Remove dirt and moisture from connector. Replace missing or damaged connector seals (WP 0113 00).</p> <p>If resistance is not as specified, replace engine position sensor (WP 0094 00).</p>

**Table 1. Error Code 1115 - Engine Position
Sensor Circuit Failure Troubleshooting Procedures - Continued.**

MALFUNCTION	TEST OR INSPECTION	CORRECTIVE ACTION
<p>Error Code 1115 - Engine Position Sensor Circuit Failure - Continued.</p>	<p>a. Measure resistance from engine position sensor connector pin A to engine block ground. Resistance should be greater than 100k Ohms.</p> <p>b. Measure resistance from engine position sensor connector pin B to engine block ground. Resistance should be greater than 100k Ohms.</p> <p>5. Remove engine position sensor from engine block (WP 0094 00). Inspect engine position sensor for damage, including metal debris on end of sensor, damage to end of sensor caused by camshaft gear or flywheel ring gear, oil leakage, or insulation problems such as swelling, and damaged electrical potting in sensing end of sensor.</p> <p>6. Check resistance of engine position sensor:</p> <p>a. Measure resistance from pin A to pin D of engine position sensor. Resistance should be 1,000 to 2,000 Ohms.</p> <p>b. Measure resistance from pin B to pin C of engine position sensor. Resistance should be 1,000 to 2,000 Ohms.</p> <p>7. Check for a short circuit between coils by measuring resistance from pin A to pin B of engine position sensor. Resistance should be greater than 100k Ohms.</p> <p>8. Disconnect sensor harness from engine ECU (794).</p>	<p>Replace damaged engine position sensor (WP 0094 00).</p> <p>If resistance is not as specified, replace engine position sensor (WP 0094 00).</p> <p>If resistance is not as specified, replace engine position sensor (WP 0094 00).</p>

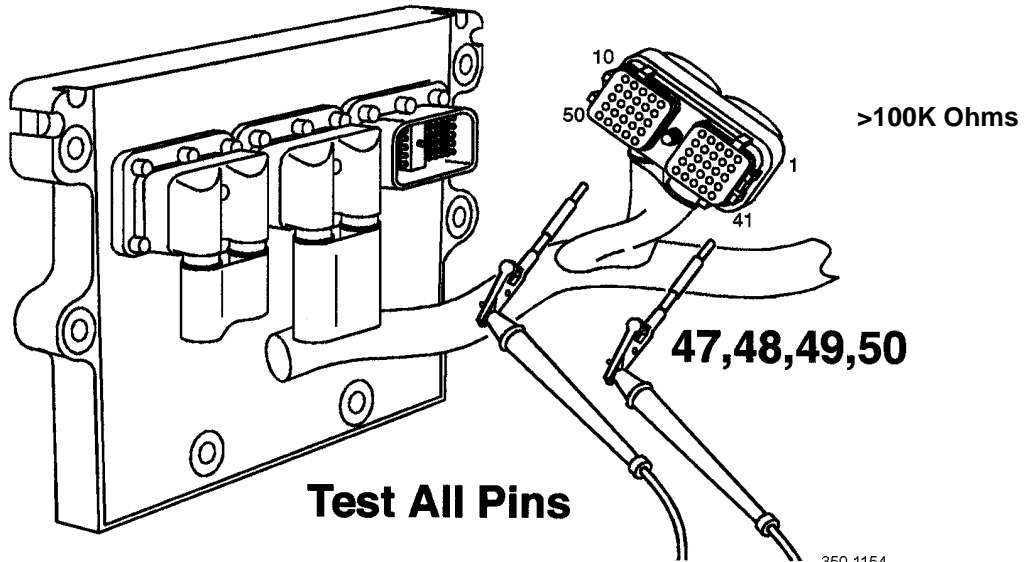
Table 1. Error Code 1115 - Engine Position
Sensor Circuit Failure Troubleshooting Procedures - Continued.

MALFUNCTION	TEST OR INSPECTION	CORRECTIVE ACTION
<p>Error Code 1115 - Engine Position Sensor Circuit Failure - Continued.</p>	<p>9. Inspect engine harness and engine ECU connectors for dirty, corroded, bent, broken, and pushed back or extended pins.</p> <p>10. Check engine harness and engine ECU for dirt or moisture in or on connectors and for missing or damaged connector seals.</p> <p>11. Check for short circuit to ground:</p> <p>a. Measure resistance from engine harness connector pin 47 to engine block ground. Resistance should be greater than 100k Ohms.</p> <p>b. Measure resistance from engine harness connector pin 50 to engine block ground. Resistance should be greater than 100k Ohms.</p>	<p>Clean and repair connector(s) as required (WP 0113 00).</p> <p>Remove dirt and moisture from connector. Replace missing or damaged connector seals (WP 0113 00).</p> <p>If engine harness requires replacement, notify Sustainment Maintenance.</p>



**Table 1. Error Code 1115 - Engine Position
Sensor Circuit Failure Troubleshooting Procedures - Continued.**

MALFUNCTION	TEST OR INSPECTION	CORRECTIVE ACTION
<p>Error Code 1115 - Engine Position Sensor Circuit Failure - Continued.</p>	<p>12. Check for short circuit from pin to pin:</p> <ul style="list-style-type: none"> a. Measure resistance from pin 47 of engine harness connector to all other pins. Resistance should be greater than 100k Ohms. b. Measure resistance from pin 48 of engine harness connector to all other pins. Resistance should be greater than 100k Ohms. c. Measure resistance from pin 49 of engine harness connector to all other pins. Resistance should be greater than 100k Ohms. d. Measure resistance from pin 50 of engine harness connector to all other pins. Resistance should be greater than 100k Ohms. 	<p>If resistance is not as specified, notify Sustainment Maintenance to replace harness.</p>




USE TEST LEAD KIT P/N 3822758

350-1154

**Table 1. Error Code 1115 - Engine Position
Sensor Circuit Failure Troubleshooting Procedures - Continued.**

MALFUNCTION	TEST OR INSPECTION	CORRECTIVE ACTION
<p>Error Code 1115 - Engine Position Sensor Circuit Failure - Continued.</p>	<p>13.Reconnect sensor harness to engine position sensor. Check for open circuit:</p> <p>a. Measure resistance from pin 49 to pin 50 of engine harness connector. Resistance should be 1,000 to 2,000 Ohms.</p> <p>b. Measure resistance from pin 47 to pin 48 of engine harness connector. Resistance should be 1,000 to 2,000 Ohms.</p>	<p>If engine harness requires replacement, notify Sustainment Maintenance.</p>

**Table 2. Error Code 1121 - Engine Position
Sensor Circuit Failure Troubleshooting Procedures.**

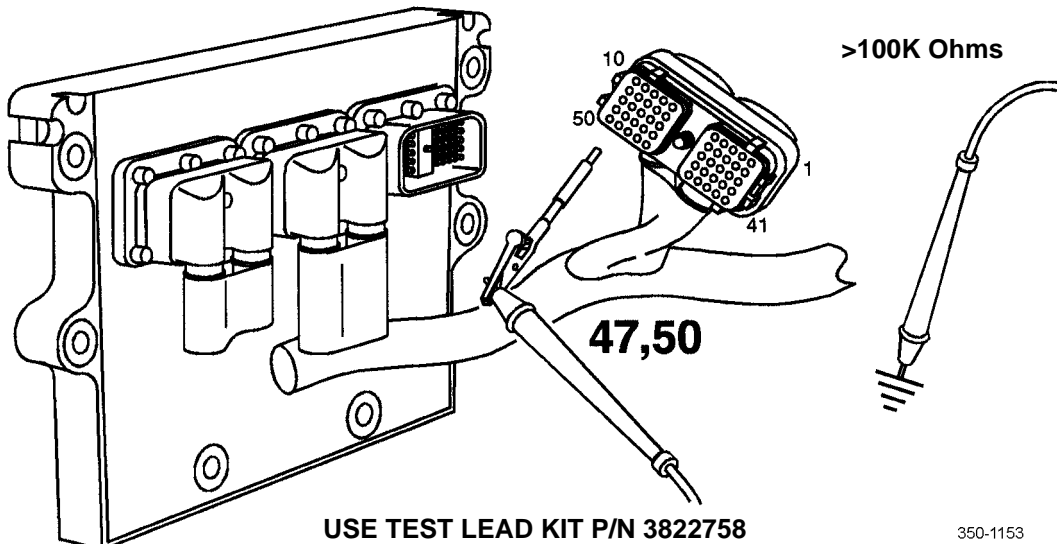
MALFUNCTION	TEST OR INSPECTION	CORRECTIVE ACTION
<p>Error Code 1121 - Engine Position Sensor Circuit Failure.</p> 	<ol style="list-style-type: none"> 1. Ensure that ignition switch is in OFF position. Disconnect engine harness from engine position sensor (WP 0094 00). 2. Inspect engine harness and engine position sensor connectors for dirty, corroded, bent, broken, and pushed back or extended pins. 3. Check engine harness and engine position sensor for dirt or moisture in or on connectors and for missing or damaged connector seals. 4. Check for short circuit to ground: <ol style="list-style-type: none"> a. Measure resistance from engine position sensor connector pin A to engine block ground. Resistance should be greater than 100k Ohms. 	<p>Clean and repair connector(s) as required (WP 0113 00).</p> <p>Remove dirt and moisture from connector. Replace missing or damaged connector seals (WP 0113 00).</p> <p>If resistance is not as specified, replace engine position sensor (WP 0094 00).</p>

**Table 2. Error Code 1121 - Engine Position
Sensor Circuit Failure Troubleshooting Procedures - Continued.**

MALFUNCTION	TEST OR INSPECTION	CORRECTIVE ACTION
<p>Error Code 1121 - Engine Position Sensor Circuit Failure - Continued.</p>	<p>b. Measure resistance from engine position sensor connector pin B to engine block ground. Resistance should be greater than 100k Ohms.</p> <p>5. Remove engine position sensor from the engine block (WP 0094 00). Inspect engine position sensor for damage, including metal debris on end of sensor, damage to end of sensor caused by camshaft gear or flywheel ring gear, oil leakage, or insulation problems such as swelling, and damaged electrical potting in sensing end of sensor.</p> <p>6. Check resistance of engine position sensor:</p> <p>a. Measure resistance from pin A to pin D of engine position sensor. Resistance should be 1,000 to 2,000 Ohms.</p> <p>b. Measure resistance from pin B to pin C of engine position sensor. Resistance should be 1,000 to 2,000 Ohms.</p> <p>7. Check for a short circuit between coils by measuring resistance from pin A to pin B of engine position sensor. Resistance should be greater than 100k Ohms.</p> <p>8. Disconnect sensor harness from engine ECU (794).</p> <p>9. Inspect engine harness and engine ECU connectors for dirty, corroded, bent, broken, and pushed back or extended pins.</p>	<p>Replace damaged engine position sensor (WP 0094 00).</p> <p>If resistance is not as specified, replace engine position sensor (WP 0094 00).</p> <p>If resistance is not as specified, replace engine position sensor (WP 0094 00).</p> <p>Clean and repair connector(s) as required (WP 0113 00).</p>

Table 2. Error Code 1121 - Engine Position
Sensor Circuit Failure Troubleshooting Procedures - Continued.

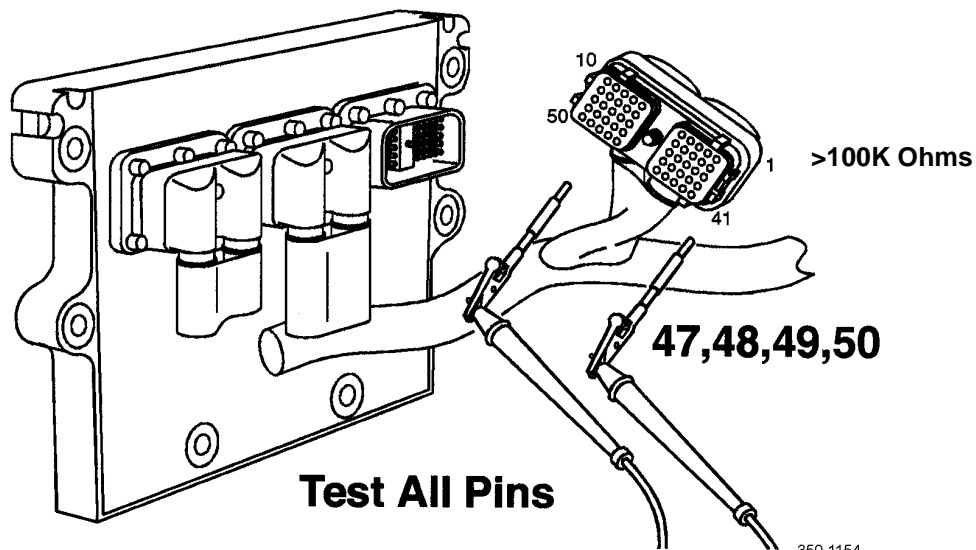
MALFUNCTION	TEST OR INSPECTION	CORRECTIVE ACTION
<p>Error Code 1121 - Engine Position Sensor Circuit Failure - Continued.</p>	<p>10. Check engine harness and engine ECU for dirt or moisture in or on connectors and for missing or damaged connector seals.</p> <p>11. Check for short circuit to ground:</p> <p>a. Measure resistance from engine harness connector pin 47 to engine block ground. Resistance should be greater than 100k Ohms.</p> <p>b. Measure resistance from engine harness connector pin 50 to engine block ground. Resistance should be greater than 100k Ohms.</p>	<p>Remove dirt and moisture from connector. Replace missing or damaged connector seals (WP 0113 00).</p> <p>If engine harness requires replacement, notify Sustainment Maintenance.</p>



USE TEST LEAD KIT P/N 3822758

Table 2. Error Code 1121 - Engine Position
Sensor Circuit Failure Troubleshooting Procedures - Continued.

MALFUNCTION	TEST OR INSPECTION	CORRECTIVE ACTION
<p>Error Code 1121 - Engine Position Sensor Circuit Failure - Continued.</p>	<p>12. Check for short circuit from pin to pin:</p> <ul style="list-style-type: none"> a. Measure resistance from pin 47 of engine harness connector to all other pins. Resistance should be greater than 100k Ohms. b. Measure resistance from pin 48 of engine harness connector to all other pins. Resistance should be greater than 100k Ohms. c. Measure resistance from pin 49 of engine harness connector to all other pins. Resistance should be greater than 100k Ohms. d. Measure resistance from pin 50 of engine harness connector to all other pins. Resistance should be greater than 100k Ohms. 	<p>If resistance is not as specified, notify Sustainment Maintenance to replace harness.</p>




USE TEST LEAD KIT P/N 3822758

350-1154

Table 2. Error Code 1121 - Engine Position Sensor Circuit Failure Troubleshooting Procedures - Continued.

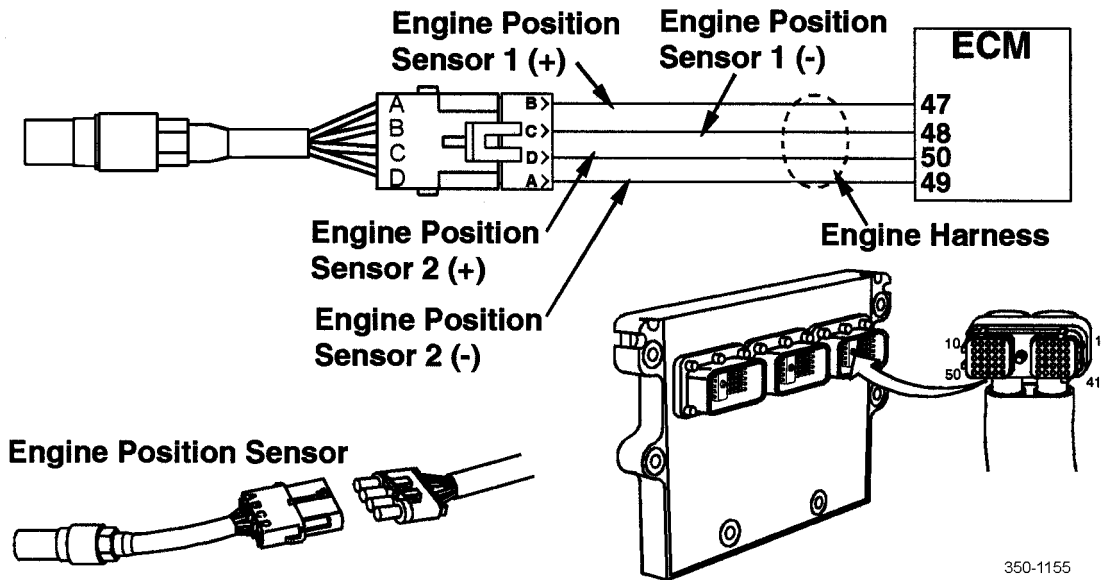
MALFUNCTION	TEST OR INSPECTION	CORRECTIVE ACTION
<p>Error Code 1121 - Engine Position Sensor Circuit Failure - Continued.</p>	<p>13.Reconnect sensor harness to engine position sensor. Check for open circuit:</p> <p>a. Measure resistance from pin 49 to pin 50 of engine harness connector. Resistance should be 1,000 to 2,000 Ohms.</p> <p>b. Measure resistance from pin 47 to pin 48 of engine harness connector. Resistance should be 1,000 to 2,000 Ohms.</p>	<p>If engine harness requires replacement, notify Sustainment Maintenance.</p>

Table 3. Error Code 1234 - Engine Overspeed Failure Troubleshooting Procedures.

MALFUNCTION	TEST OR INSPECTION	CORRECTIVE ACTION
<p>Error Code 1234 - Engine Overspeed Failure.</p> 		<p>Notify Sustainment Maintenance.</p>

NOTE

Engine position sensor is located on left side of engine, below A/C compressor.



END OF WORK PACKAGE

ENGINE OIL PRESSURE SENSOR TROUBLESHOOTING

0020 00

THIS WORK PACKAGE COVERS

Error Code 1135 - Oil Pressure Sensor Circuit Failure
 Error Code 1141 - Oil Pressure Sensor Circuit Failure
 Error Code 1143 - Oil Pressure Sensor Circuit Failure

Error Code 1415 - Oil Pressure Sensor Circuit Failure
 Error Code 1435 - Oil Pressure Sensor Circuit Failure

INITIAL SETUP

Tools and Special Tools

Test Lead, Female (Item 121, WP 0289 00)
 Test Lead, Male (Item 124, WP 0289 00)

References

TM 10-3930-675-10-1

NOTE

- Refer to WP 0004 00 for additional troubleshooting guidance, information, and illustrations that locate critical components.
- Refer also to illustration at end of work package for component location.

Table 1. Error Code 1135 - Oil Pressure Sensor Circuit Failure Troubleshooting Procedures.


MALFUNCTION	TEST OR INSPECTION	CORRECTIVE ACTION
<p>Error Code 1135 - Oil Pressure Sensor Circuit Failure.</p> 	<p>1. Ensure ignition switch is in OFF position. Disconnect engine harness from oil pressure/temperature sensor (WP 0094 00).</p> <p>a. Inspect engine harness and oil pressure/temperature sensor connectors for dirty, corroded, bent, broken, and pushed back or extended pins.</p> <p>b. Check engine harness and oil pressure/temperature sensor for dirt or moisture in or on connectors and for missing or damaged connector seals.</p>	<p>Clean and repair connector(s) as required (WP 0113 00).</p> <p>Remove dirt and moisture from connector. Replace missing or damaged connector seals (WP 0113 00).</p>

Table 1. Error Code 1135 - Oil Pressure Sensor Circuit Failure Troubleshooting Procedures - Continued.

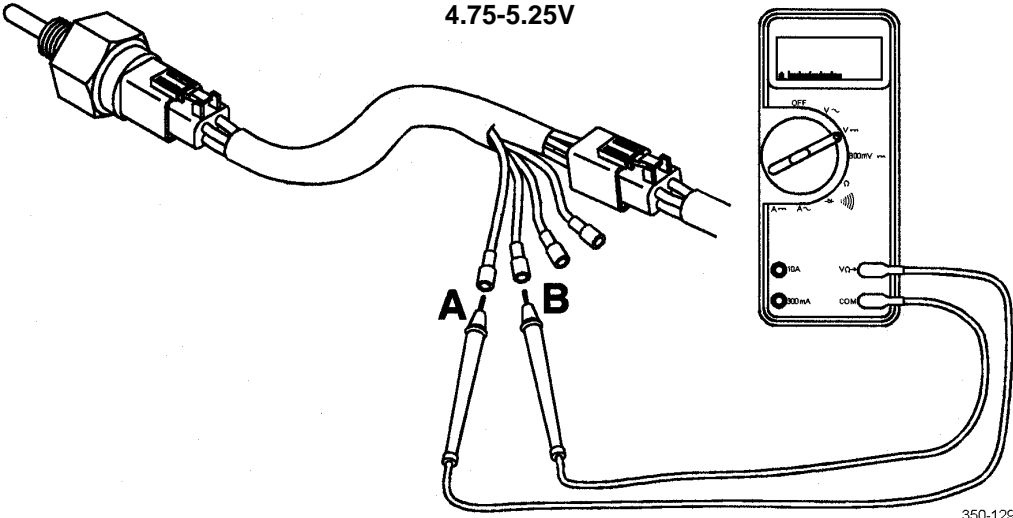
MALFUNCTION	TEST OR INSPECTION	CORRECTIVE ACTION
<p>Error Code 1135 - Oil Pressure Sensor Circuit Failure - Continued.</p>	<p>2. Install breakout cable between sensor and engine harness connector. Place ignition switch in ON position.</p> <p>3. Measure supply voltage from pin A (or RED) to pin B (or BLACK) of breakout cable. Voltage should be 4.75 to 5.25V.</p>	<p>If voltage is not as specified, proceed to step 4.</p>
 <p>4.75-5.25V</p> <p>350-1299</p>		
	<p>4. Disconnect sensor harness connector from engine ECU. Place ignition switch in ON position.</p>	

Table 1. Error Code 1135 - Oil Pressure Sensor Circuit Failure Troubleshooting Procedures - Continued.

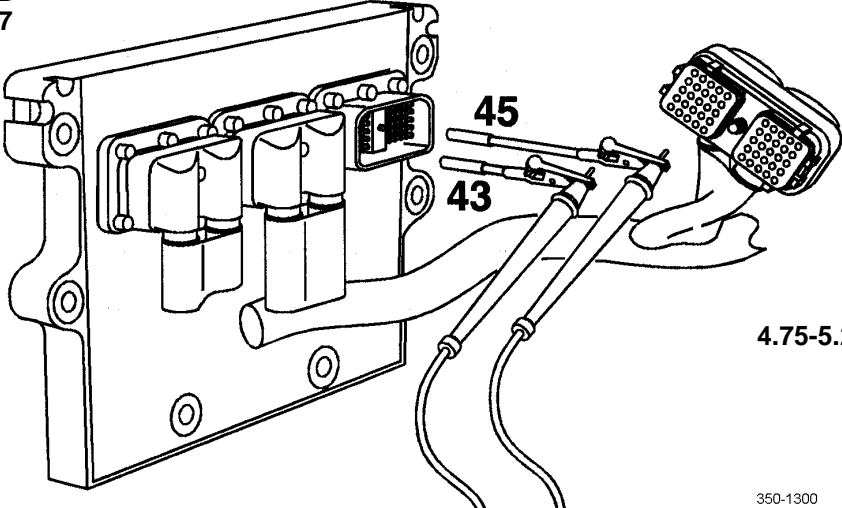
MALFUNCTION	TEST OR INSPECTION	CORRECTIVE ACTION
<p>Error Code 1135 - Oil Pressure Sensor Circuit Failure - Continued.</p>	<p>5. Measure voltage at ECU from pin 45 to pin 43 of ECU sensor port. Voltage should be 4.75 to 5.25V.</p>	<p>a. If voltage is as specified, proceed to step 6. b. If voltage is not as specified, replace engine ECU (WP007900).</p>
<p>USE TEST LEAD KIT P/N 3822917</p>  <p style="text-align: right;">4.75-5.25V</p> <p style="text-align: right; font-size: small;">350-1300</p>		
<p>6. Install breakout cable between sensor and engine harness connector. Place ignition switch in ON position.</p>		

Table 1. Error Code 1135 - Oil Pressure Sensor Circuit Failure Troubleshooting Procedures - Continued.

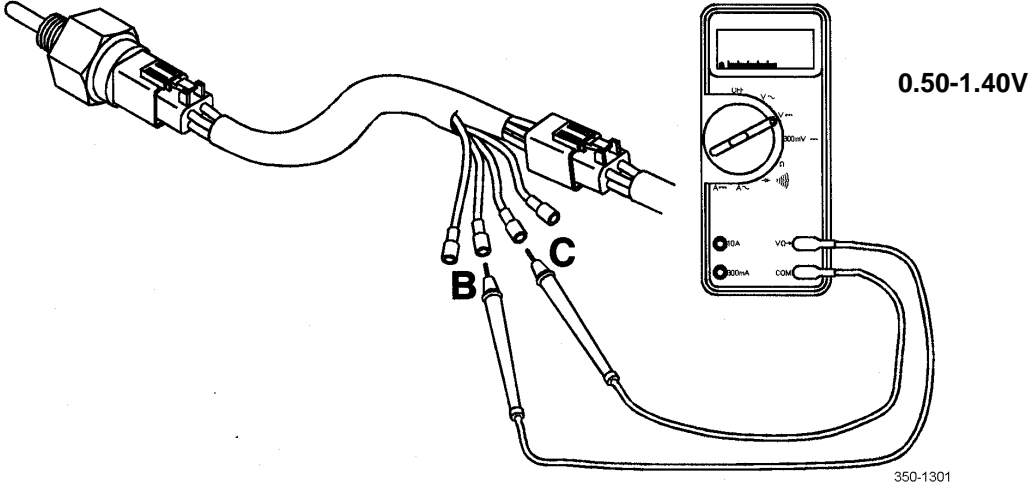
MALFUNCTION	TEST OR INSPECTION	CORRECTIVE ACTION
<p>Error Code 1135 - Oil Pressure Sensor Circuit Failure - Continued.</p>	<p>7. Measure supply voltage from pin C (or YELLOW) to pin B (or BLACK) of breakout cable. Voltage should be 0.50 to 1.40V.</p> 	<p>If voltage is not as specified, proceed with the following steps.</p> <p>8. Ensure ignition switch is in OFF position. Disconnect sensor harness from engine ECU.</p> <p>a. Inspect sensor harness and engine ECU connectors for dirty, corroded, bent, broken, and pushed back or extended pins.</p> <p>b. Check sensor harness and engine ECU for dirt or moisture in or on connectors and for missing or damaged connector seals.</p>
		<p>Clean and repair connector(s) as required (WP 0113 00).</p> <p>Remove dirt and moisture from connector. Replace missing or damaged connector seals (WP 0113 00).</p>

Table 1. Error Code 1135 - Oil Pressure Sensor Circuit Failure Troubleshooting Procedures - Continued.

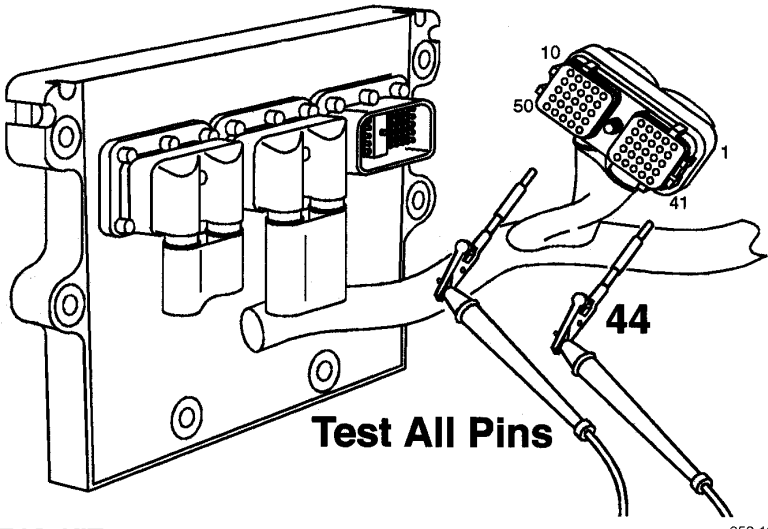
MALFUNCTION	TEST OR INSPECTION	CORRECTIVE ACTION
<p>Error Code 1135 - Oil Pressure Sensor Circuit Failure - Continued.</p>	<p>9. Place ignition switch in OFF position and disconnect sensor harness from engine ECU.</p> <p>10. Measure resistance from pin 44 of sensor harness connector to all other pins in connector. Resistance should be greater than 100k Ohms.</p>	<p>If engine harness requires replacement, notify Sustainment Maintenance.</p>
 <p>USE TEST LEAD KIT P/N 3822758</p> <p>Test All Pins</p> <p>>100K Ohms</p> <p>350-1302</p>		
	<p>11. Place ignition switch in OFF position. Disconnect sensor harness from engine ECU and disconnect engine harness from oil pressure/temperature sensor.</p>	

Table 1. Error Code 1135 - Oil Pressure Sensor Circuit Failure Troubleshooting Procedures - Continued.

MALFUNCTION	TEST OR INSPECTION	CORRECTIVE ACTION
<p>Error Code 1135 - Oil Pressure Sensor Circuit Failure - Continued.</p>	<p>12. Measure resistance from pin 43 of sensor harness connector to pin B (or 2) on harness side of oil pressure/temperature sensor connector. Resistance should be less than 10 Ohms.</p>	<p>a. If resistance is as specified, replace oil pressure/temperature sensor (WP 0094 00). b. If resistance is not as specified, repair or replace connectors (WP 0113 00). c. If engine harness requires replacement, notify Sustainment Maintenance.</p>

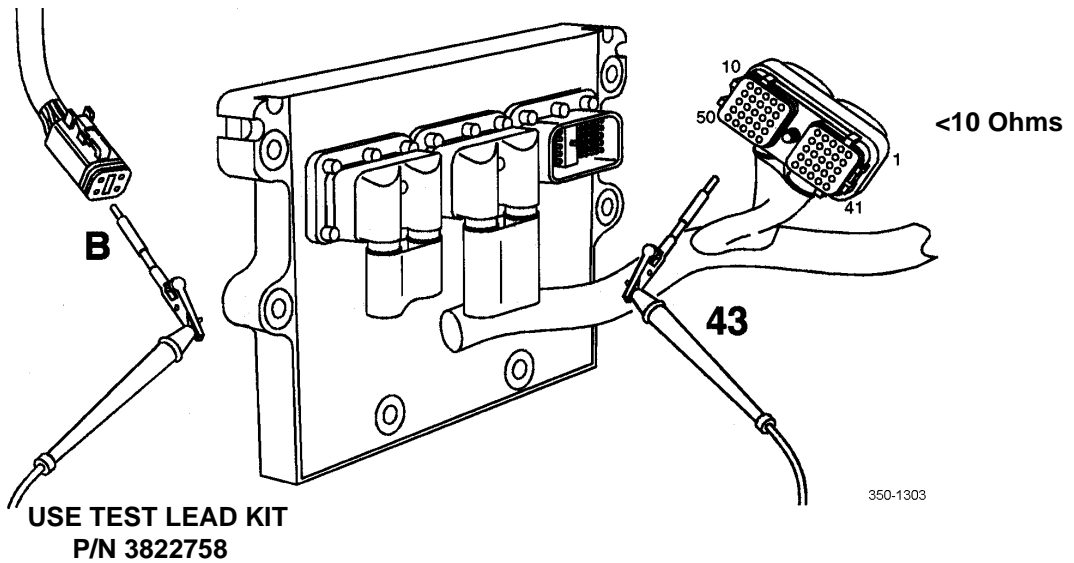


Table 2. Error Code 1141 - Oil Pressure Sensor Circuit Failure Troubleshooting Procedures.


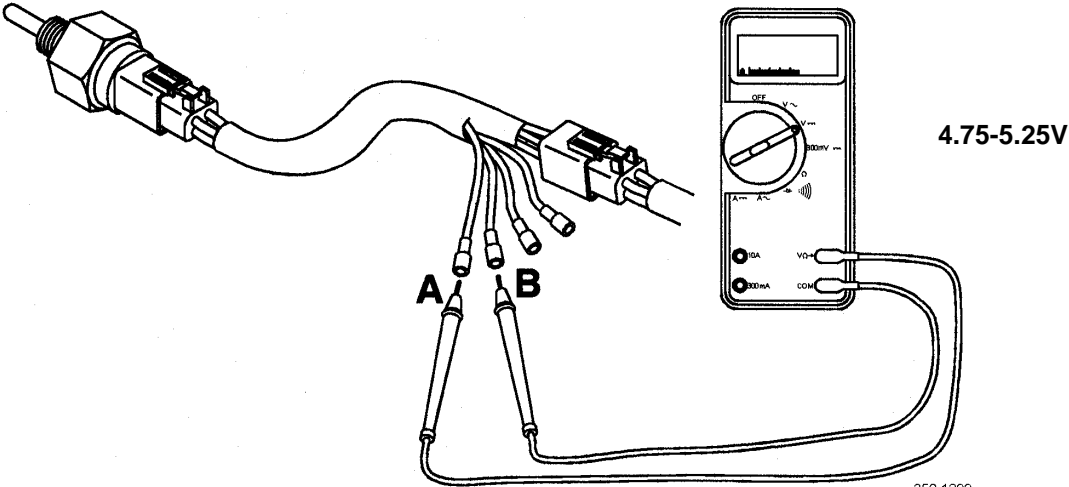
MALFUNCTION	TEST OR INSPECTION	CORRECTIVE ACTION
<p>Error Code 1141 - Oil Pressure Sensor Circuit Failure.</p> 	<ol style="list-style-type: none"> 1. Ensure ignition switch is in OFF position. Disconnect engine harness from oil pressure/temperature sensor (WP 0094 00). <ol style="list-style-type: none"> a. Inspect engine harness and oil pressure/temperature sensor connectors for dirty, corroded, bent, broken, and pushed back or extended pins. b. Check engine harness and oil pressure/temperature sensor for dirt or moisture in or on the connectors and for missing or damaged connector seals. 2. Install breakout cable between sensor and engine harness connector. Place ignition switch in ON position. 3. Measure supply voltage from pin A (or RED) to pin B (or BLACK) of breakout cable. Voltage should be 4.75 to 5.25V. 	<p>Clean and repair connector(s) as required (WP 0113 00).</p> <p>Remove dirt and moisture from connector. Replace missing or damaged connector seals (WP 0113 00).</p> <p>If voltage is not as specified, proceed with the following steps.</p>
 <p style="text-align: right;">350-1299</p>		

Table 2. Error Code 1141 - Oil Pressure Sensor Circuit Failure Troubleshooting Procedures - Continued.

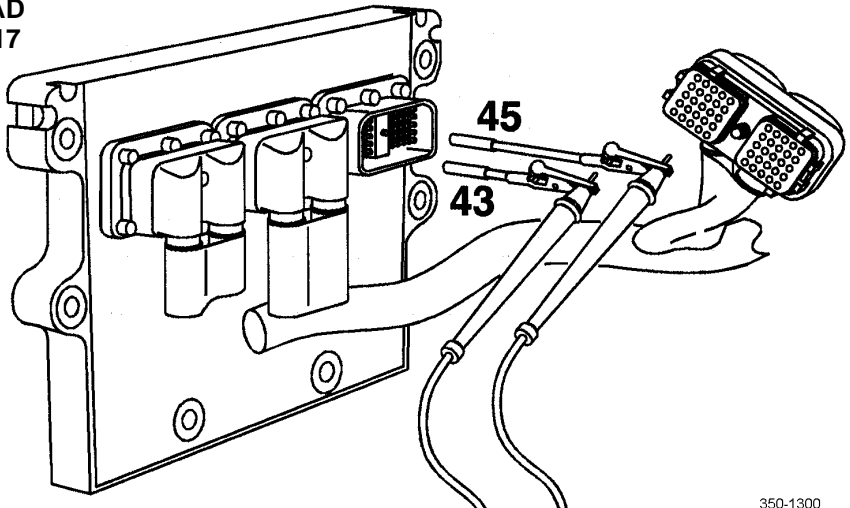
MALFUNCTION	TEST OR INSPECTION	CORRECTIVE ACTION
<p>Error Code 1141 - Oil Pressure Sensor Circuit Failure - Continued.</p> <p>USE TEST LEAD KIT P/N 3822917</p> 	<p>4. Disconnect sensor harness connector from engine ECU. Place ignition switch in ON position.</p> <p>5. Measure voltage at ECU from pin 45 to pin 43 of ECU sensor port. Voltage should be 4.75 to 5.25V.</p>	<p>a. If voltage is as specified, proceed to step 6.</p> <p>b. If voltage is not as specified, replace engine ECU (WP007900).</p>
	<p>6. Install breakout cable between sensor and engine harness connector. Place ignition switch in ON position.</p>	

Table 2. Error Code 1141 - Oil Pressure Sensor Circuit Failure Troubleshooting Procedures - Continued.

MALFUNCTION	TEST OR INSPECTION	CORRECTIVE ACTION
<p>Error Code 1141 - Oil Pressure Sensor Circuit Failure - Continued.</p>	<p>7. Measure supply voltage from pin C (or YELLOW) to pin B (or BLACK) of breakout cable. Voltage should be 0.50 to 1.40V.</p>	<p>If voltage is not as specified, proceed with the following steps.</p>
	<p>8. Ensure that ignition switch is in OFF position. Disconnect engine harness from oil pressure/temperature sensor and disconnect sensor harness from engine ECU.</p>	

Table 2. Error Code 1141 - Oil Pressure Sensor Circuit Failure Troubleshooting Procedures - Continued.

MALFUNCTION	TEST OR INSPECTION	CORRECTIVE ACTION
<p>Error Code 1141 - Oil Pressure Sensor Circuit Failure - Continued.</p>	<p>9. Measure resistance from pin 44 (or pressure signal) of sensor harness connector to chassis ground. Resistance should be greater than 100k Ohms.</p>	<p>If resistance is not as specified, notify Sustainment Maintenance to replace engine harness.</p>
<p>USE TEST LEAD KIT P/N 3822758</p> <p>350-1305</p>		
	<p>10. Ensure ignition switch is in OFF position. Disconnect engine harness from oil pressure/temperature sensor and disconnect sensor harness from engine ECU.</p> <p>11. Measure resistance from pin 44 (or pressure signal) of sensor harness connector to all other pins in connector. Resistance should be greater than 100k Ohms.</p>	<p>a. If resistance is as specified, replace oil pressure/temperature sensor (WP 0094 00).</p> <p>b. If resistance is not as specified, notify Sustainment Maintenance to replace engine harness.</p>

Table 2. Error Code 1141 - Oil Pressure Sensor Circuit Failure Troubleshooting Procedures - Continued.

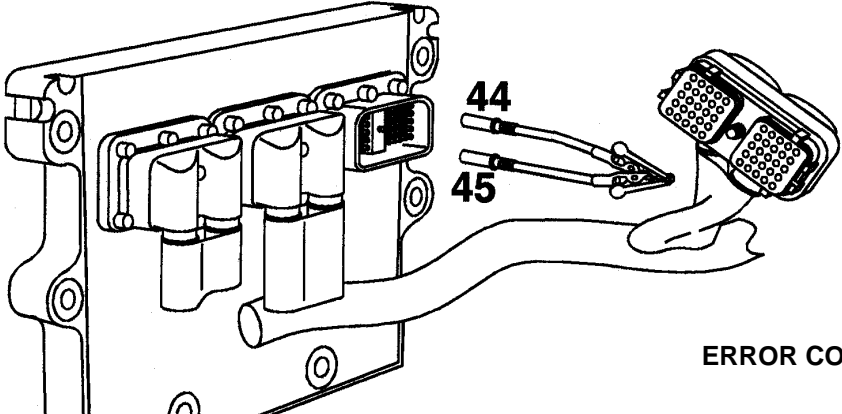
MALFUNCTION	TEST OR INSPECTION	CORRECTIVE ACTION
<p>Error Code 1141 - Oil Pressure Sensor Circuit Failure - Continued.</p> <div data-bbox="397 493 1331 1018" style="text-align: center;"> <p>Test All Pins</p> <p>USE TEST LEAD KIT P/N 3822758</p> <p>>100K Ohms</p> <p>350-1302</p> </div>	<p>12. Ensure ignition switch is in OFF position. Disconnect sensor harness from engine ECU.</p> <p>a. Inspect sensor harness and engine ECU connectors for dirty, corroded, bent, broken, and pushed back or extended pins.</p> <p>b. Check sensor harness and engine ECU for dirt or moisture in or on connectors and for missing or damaged connector seals.</p>	<p>Clean and repair connector(s) as required (WP 0113 00).</p> <p>Remove dirt and moisture from connector. Replace missing or damaged connector seals (WP 0113 00).</p>

Table 2. Error Code 1141 - Oil Pressure Sensor Circuit Failure Troubleshooting Procedures - Continued.

MALFUNCTION	TEST OR INSPECTION	CORRECTIVE ACTION
<p>Error Code 1141 - Oil Pressure Sensor Circuit Failure - Continued.</p>	<p>13. Place ignition switch in OFF position. Disconnect engine harness from oil pressure/temperature sensor and disconnect sensor harness from engine ECU.</p> <p>14. Measure resistance from pin 44 (or pressure signal) of sensor harness connector to pin C (or 3) of oil pressure/temperature sensor connector on harness side. Resistance should be less than 10 Ohms.</p>	<p>a. If resistance is not as specified, repair or replace connectors (WP 0113 00).</p> <p>b. If engine harness requires replacement, notify Sustainment Maintenance.</p>
<p>15. Disconnect sensor harness connector from engine ECU. Place ignition switch in ON position.</p>		

Table 2. Error Code 1141 - Oil Pressure Sensor Circuit Failure Troubleshooting Procedures - Continued.

MALFUNCTION	TEST OR INSPECTION	CORRECTIVE ACTION
<p>Error Code 1141 - Oil Pressure Sensor Circuit Failure - Continued.</p>	<p>16. Install a jumper wire between engine ECU sensor port pins 44 and 45, with 5V supply applied. Error code 1135 should be displayed.</p>	<p>If error code 135 was not displayed, replace engine ECU (WP 0079 00).</p>



ERROR CODE 1135

350-1307

Table 3. Error Code 1143 - Oil Pressure Sensor Circuit Failure Troubleshooting Procedures.


MALFUNCTION	TEST OR INSPECTION	CORRECTIVE ACTION
<p>Error Code 1143 - Oil Pressure Sensor Circuit Failure.</p> 	<p>Perform Troubleshooting procedure for "Engine Oil Pressure - Low" (WP 0007 00).</p>	

Table 4. Error Code 1415 - Oil Pressure Sensor Circuit Failure Troubleshooting Procedures.



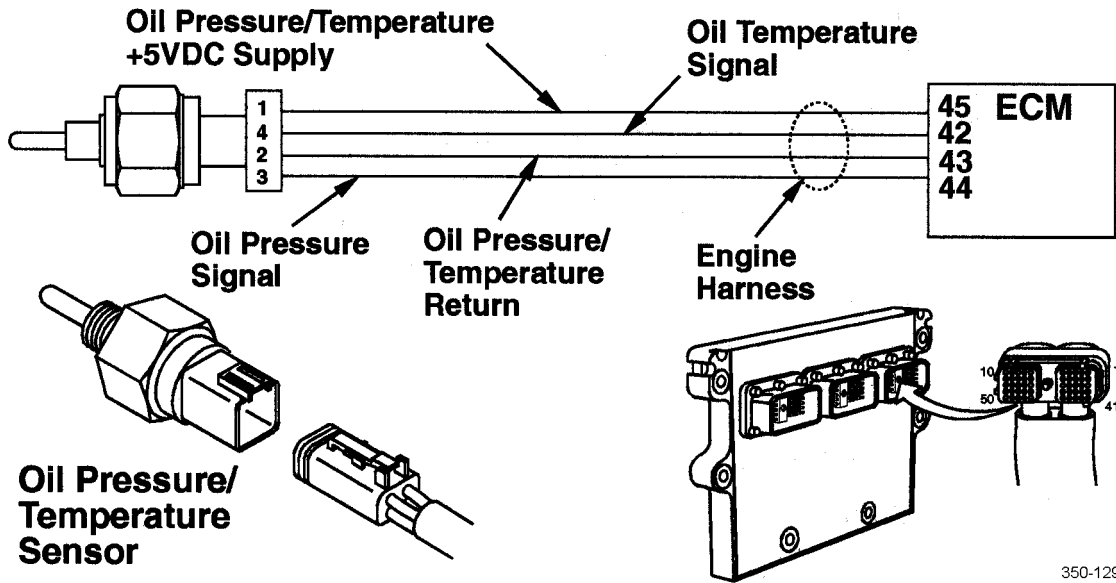
MALFUNCTION	TEST OR INSPECTION	CORRECTIVE ACTION
<p>Error Code 1415 - Oil Pressure Sensor Circuit Failure.</p> 	<p>Perform Troubleshooting procedure for "Engine Oil Pressure - Low" (WP 0007 00).</p>	

Table 5. Error Code 1435 - Oil Pressure Sensor Circuit Failure Troubleshooting Procedures.

MALFUNCTION	TEST OR INSPECTION	CORRECTIVE ACTION
<p>Error Code 1435 - Oil Pressure Sensor Circuit Failure.</p> 	<p>Perform Troubleshooting procedure for Error Codes 1135 and 1141 in this work package.</p>	

NOTE

Oil pressure/temperature sensor is located on left side of engine, at rear of A/C compressor.



350-1298

END OF WORK PACKAGE

ENGINE TEMPERATURE SENSORS AND CIRCUITS TROUBLESHOOTING

0021 00**THIS WORK PACKAGE COVERS**

Error Code 1144 - Coolant Temperature Sensor Circuit Failure

Error Code 1145 - Coolant Temperature Sensor Circuit Failure

Error Code 1151 - Coolant Temperature Sensor Circuit Failure

Error Code 1153 - Intake Air Temperature Sensor Circuit Failure

Error Code 1154 - Intake Air Temperature Sensor Circuit Failure

Error Code 1155 - Intake Air Temperature Sensor Circuit Failure

Error Code 1212 - Oil Temperature Sensor Circuit Failure

Error Code 1213 - Oil Temperature Sensor Circuit Failure

Error Code 1214 - Oil Temperature Sensor Circuit Failure

Error Code 1697 - ECU Internal Temperature Sensor Circuit Failure

Error Code 1698 - ECU Internal Temperature Sensor Circuit Failure

INITIAL SETUP**Tools and Special Tools**

Cable, Test/Repair (Item 15, WP 0289 00)

Test Lead, Female (Item 121, WP 0289 00)

Test Lead, Male (Item 124, WP 0289 00)

References

TM 10-3930-675-10

Current Supply (A34738.0200) (WP 0048 00-31)

**WARNING**

DO NOT remove cooling system radiator cap when engine is hot. Allow engine to cool down. Failure to follow this warning may cause serious burns.

NOTE

- Refer to WP 0004 00 for additional troubleshooting guidance, information, and illustrations that locate critical components.
- Refer also to illustrations at end of work package for component location.

Table 1. Error Code 1144 - Coolant Temperature Sensor Circuit Failure Troubleshooting Procedures.


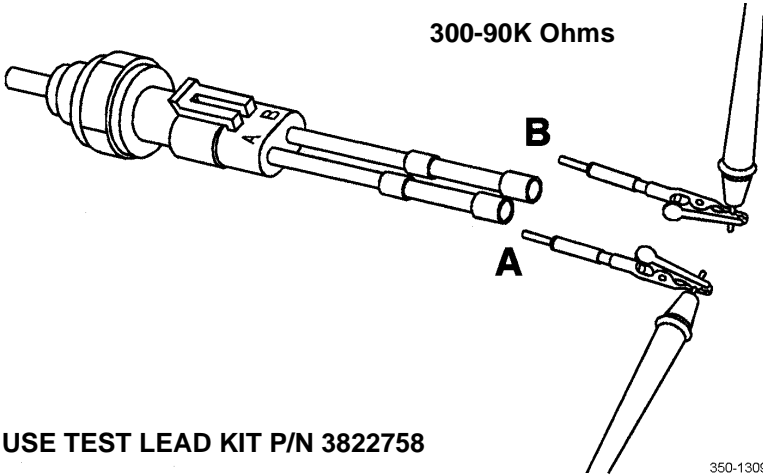
MALFUNCTION	TEST OR INSPECTION	CORRECTIVE ACTION
<p>Error Code 1144 - Coolant Temperature Sensor Circuit Failure.</p> 	<ol style="list-style-type: none"> 1. Ensure ignition switch is in OFF position. Disconnect sensor harness from coolant temperature sensor (WP 0094 00). <ol style="list-style-type: none"> a. Inspect coolant temperature sensor and sensor harness connectors for dirty, corroded, bent, broken, and pushed back or extended pins. b. Check coolant temperature sensor and sensor harness for dirt or moisture in or on connectors and for missing or damaged connector seals. 2. Place ignition switch in OFF position and disconnect engine harness from coolant temperature sensor. 3. Measure resistance from pin A (or 1) to pin B (or 2) of coolant temperature sensor. Resistance should be 300 to 90k Ohms. 	<p>Clean and repair connector(s) as required (WP 0113 00).</p> <p>Remove dirt and moisture from connector. Replace missing or damaged connector seals (WP 0113 00).</p> <p>If resistance is not as specified, replace coolant temperature sensor (WP 0094 00).</p>
<div style="text-align: center;"> <p>300-90K Ohms</p>  <p>USE TEST LEAD KIT P/N 3822758</p> <p style="text-align: right; font-size: small;">350-1309</p> </div>		

Table 1. Error Code 1144 - Coolant Temperature Sensor Circuit Failure Troubleshooting Procedures - Continued.

MALFUNCTION	TEST OR INSPECTION	CORRECTIVE ACTION
<p>Error Code 1144 - Coolant Temperature Sensor Circuit Failure - Continued.</p>	<p>4. Ensure ignition switch is in OFF position. Disconnect sensor harness connector from engine ECU.</p> <p>a. Inspect engine ECU and sensor harness connectors for dirty, corroded, bent, broken, and pushed back or extended pins.</p> <p>b. Check engine ECU and sensor harness for dirt or moisture in or on connectors and for missing or damaged connector seals.</p>	<p>Clean and repair connector(s) as required (WP 0113 00).</p> <p>Remove dirt and moisture from connector. Replace missing or damaged connector seals (WP 0113 00).</p>

Table 1. Error Code 1144 - Coolant Temperature Sensor Circuit Failure Troubleshooting Procedures - Continued.

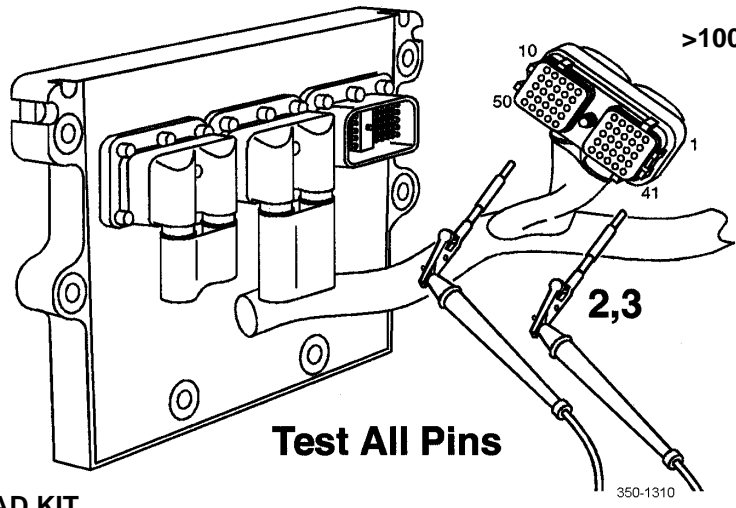
MALFUNCTION	TEST OR INSPECTION	CORRECTIVE ACTION
<p>Error Code 1144 - Coolant Temperature Sensor Circuit Failure - Continued.</p>	<p>5. Place ignition switch in OFF position. Disconnect engine harness from coolant temperature sensor and disconnect sensor harness connector from engine ECU. Perform the following resistance checks:</p> <ul style="list-style-type: none"> a. Measure resistance from pin 2 of sensor harness connector to all other pins. Resistance should be greater than 100k Ohms. b. Measure resistance from pin 3 of sensor harness connector to all other pins. Resistance should be greater than 100k Ohms. 	<p>If engine harness requires replacement, notify Sustainment Maintenance.</p>
 <p>Test All Pins</p> <p>USE TEST LEAD KIT P/N 3822758</p> <p>>100K Ohms</p> <p>350-1310</p>		
	<p>6. Place ignition switch in OFF position. Disconnect engine harness from coolant temperature sensor and disconnect sensor harness connector from engine ECU. Perform the following resistance checks.</p>	<p>If engine harness requires replacement, notify Sustainment Maintenance.</p>

Table 1. Error Code 1144 - Coolant Temperature Sensor Circuit Failure Troubleshooting Procedures - Continued.

MALFUNCTION	TEST OR INSPECTION	CORRECTIVE ACTION
<p>Error Code 1144 - Coolant Temperature Sensor Circuit Failure - Continued.</p>	<p>a. Measure resistance from pin 2 of sensor harness connector to pin B (or 2) of coolant temperature sensor connector. Resistance should be less than 10 Ohms.</p> <p>b. Measure resistance from pin 3 of sensor harness connector to pin A (or 1) of coolant temperature sensor connector. Resistance should be less than 10 Ohms.</p>	

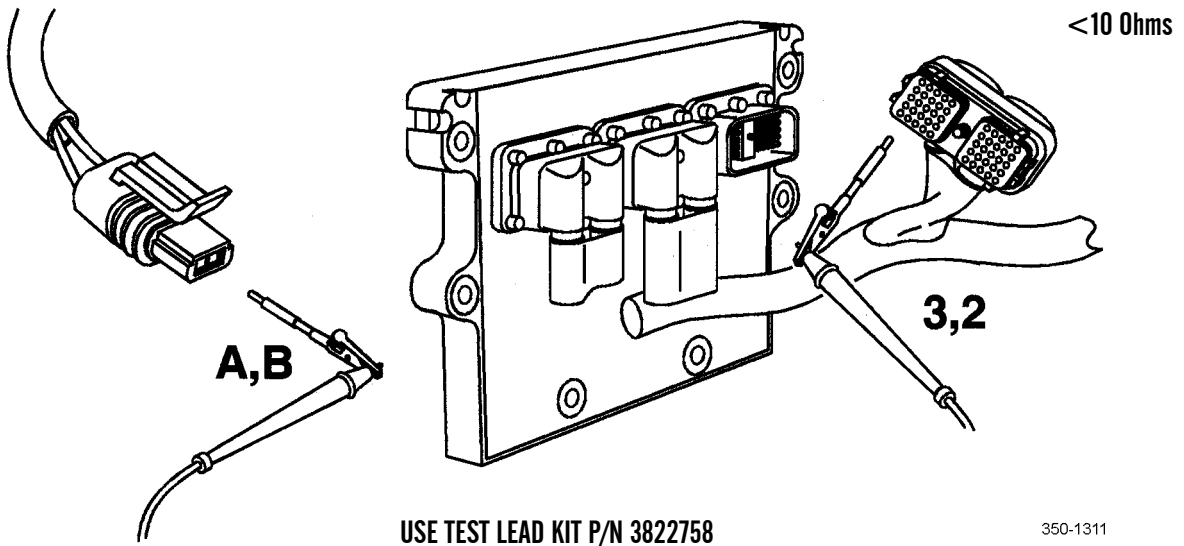

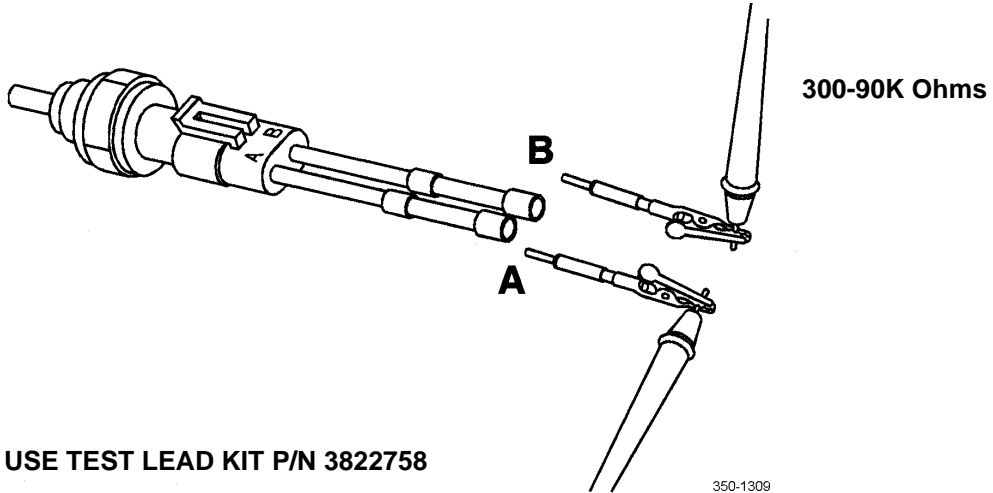


Table 2. Error Code 1145 - Coolant Temperature Sensor Circuit Failure Troubleshooting Procedures.

MALFUNCTION	TEST OR INSPECTION	CORRECTIVE ACTION
<p>Error Code 1145 - Coolant Temperature Sensor Circuit Failure.</p> 	<ol style="list-style-type: none"> 1. Ensure ignition switch is in OFF position. Disconnect sensor harness from coolant temperature sensor (WP 0094 00). <ol style="list-style-type: none"> a. Inspect coolant temperature sensor and sensor harness connectors for dirty, corroded, bent, broken, and pushed back or extended pins. b. Check coolant temperature sensor and sensor harness for dirt or moisture in or on connectors and for missing or damaged connector seals. 2. Place ignition switch in OFF position and disconnect engine harness from coolant temperature sensor. 3. Measure resistance from pin A (or 1) to pin B (or 2) of coolant temperature sensor. Resistance should be 300 to 90k Ohms. 	<p>Clean and repair connector(s) as required (WP 0113 00).</p> <p>Remove dirt and moisture from connector. Replace missing or damaged connector seals (WP 0113 00).</p> <p>If resistance is not as specified, replace coolant temperature sensor (WP 0094 00).</p>



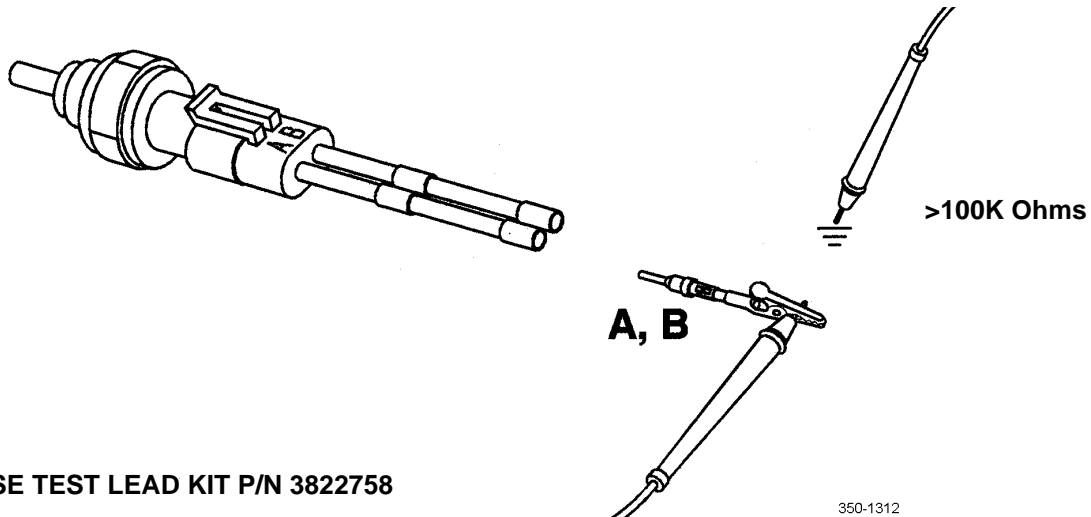
300-90K Ohms

USE TEST LEAD KIT P/N 3822758

350-1309

Table 2. Error Code 1145 - Coolant Temperature Sensor Circuit Failure Troubleshooting Procedures - Continued.

MALFUNCTION	TEST OR INSPECTION	CORRECTIVE ACTION
<p>Error Code 1145 - Coolant Temperature Sensor Circuit Failure - Continued.</p>	<p>4. Place ignition switch in OFF position and disconnect engine harness from coolant temperature sensor. Perform the following resistance checks:</p> <p>a. Measure resistance from pin A (or 1) of coolant temperature sensor to engine block ground. Resistance should be greater than 100k Ohms.</p> <p>b. Measure resistance from pin B (or 2) of coolant temperature sensor to engine block ground. Resistance should be greater than 100k Ohms.</p>	<p>If resistance is not as specified, replace coolant temperature sensor (WP 0094 00).</p>

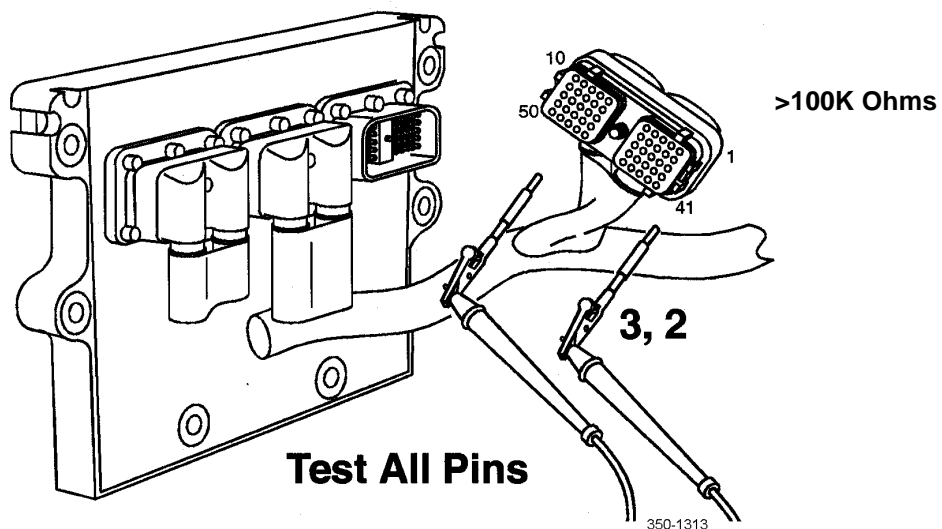


5. Place ignition switch in OFF position. Disconnect sensor harness from engine ECU.

6. Ensure ignition switch is in OFF position. Disconnect sensor harness from coolant temperature sensor.

Table 2. Error Code 1145 - Coolant Temperature Sensor Circuit Failure Troubleshooting Procedures - Continued.

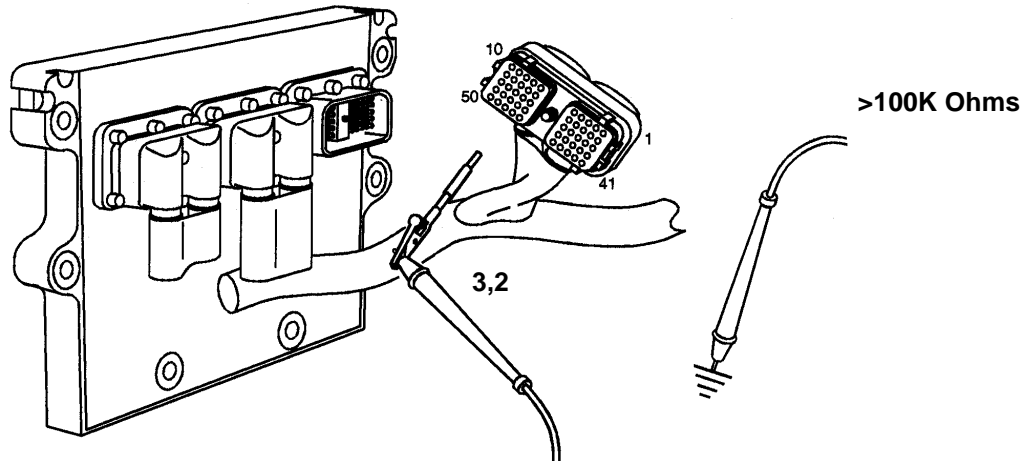
MALFUNCTION	TEST OR INSPECTION	CORRECTIVE ACTION
<p>Error Code 1145 - Coolant Temperature Sensor Circuit Failure - Continued.</p>	<p>a. Inspect sensor harness and engine ECU connectors for dirty, corroded, bent, broken, and pushed back or extended pins.</p> <p>b. Check sensor harness and engine ECU for dirt or moisture in or on connectors and for missing or damaged connector seals.</p> <p>7. Place ignition switch in OFF position. Disconnect engine harness from coolant temperature sensor and disconnect sensor harness connector from engine ECU. Perform the following resistance checks:</p> <p>a. Measure resistance from pin 2 of sensor harness connector to all other pins in connector. Resistance should be greater than 100k Ohms.</p>	<p>Clean and repair connector(s) as required (WP 0113 00).</p> <p>Remove dirt and moisture from connector. Replace missing or damaged connector seals (WP 0113 00).</p> <p>If engine harness requires replacement, notify Sustainment Maintenance.</p>



USE TEST LEAD KIT P/N 3822758

Table 2. Error Code 1145 - Coolant Temperature Sensor Circuit Failure Troubleshooting Procedures - Continued.

MALFUNCTION	TEST OR INSPECTION	CORRECTIVE ACTION
<p>Error Code 1145 - Coolant Temperature Sensor Circuit Failure - Continued.</p>	<p>b. Measure resistance from pin 3 of sensor harness connector to all other pins in connector. Resistance should be greater than 100k Ohms.</p> <p>8. Place ignition switch in OFF position. Disconnect engine harness from coolant temperature sensor and disconnect sensor harness connector from engine ECU. Perform the following resistance checks:</p> <p>a. Measure resistance from pin 2 of sensor harness connector to engine block ground. Resistance should be greater than 100k Ohms.</p> <p>b. Measure resistance from pin 3 of sensor harness connector to engine block ground. Resistance should be greater than 100k Ohms.</p>	<p>If engine harness requires replacement, notify Sustainment Maintenance.</p>



USE TEST LEAD KIT P/N 3822758

350-1358

Table 3. Error Code 1151 - Coolant Temperature Sensor Circuit Failure Troubleshooting Procedures.


MALFUNCTION	TEST OR INSPECTION	CORRECTIVE ACTION
<p data-bbox="159 415 717 472">Error Code 1151 - Coolant Temperature Sensor Circuit Failure.</p> 	<ol style="list-style-type: none"> <li data-bbox="734 415 1088 472">1. Check coolant level (TM 10-3930-675-10). <li data-bbox="734 499 1088 583">2. Check radiator top and side grille for mud, snow, or obstructions. <li data-bbox="734 674 1088 737">3. Check for loose coolant hoses and clamps. <li data-bbox="734 758 1088 966">4. Enter "DIAG EXTRA FUNCT" 4(13) menu and check water level sensor setting. Enter "0" to shut off and "1" to run cooling fan. Check if fording water level sensor is clogged or damaged. 	<p data-bbox="1107 415 1461 472">Add coolant as required (TM 10-3930-675-10).</p> <p data-bbox="1107 499 1307 520">Clear obstructions.</p> <p data-bbox="1107 674 1429 737">Tighten or replace as required (WP 0065 00).</p> <ol style="list-style-type: none"> <li data-bbox="1107 758 1461 842">a. Clean and/or replace fording water level sensor (WP 0091 00). <li data-bbox="1107 852 1461 966">b. Perform Troubleshooting Procedure for "Engine OVERHEATS" (WP 0007 00).

Table 4. Error Code 1153 - Intake Air Temperature Sensor Circuit Failure Troubleshooting Procedures.

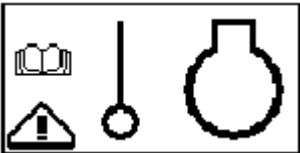
MALFUNCTION	TEST OR INSPECTION	CORRECTIVE ACTION
<p data-bbox="159 1171 717 1228">Error Code 1153 - Intake Air Temperature Sensor Circuit Failure.</p> 	<ol style="list-style-type: none"> <li data-bbox="734 1171 1088 1291">1. Ensure ignition switch is in OFF position. Disconnect sensor harness from intake manifold temperature sensor. <ol style="list-style-type: none"> <li data-bbox="761 1312 1088 1491">a. Inspect intake manifold temperature sensor and sensor harness connectors for dirty, corroded, bent, broken, and pushed back or extended pins. <li data-bbox="761 1512 1088 1690">b. Check intake manifold temperature sensor and sensor harness for dirt or moisture in or on connectors and for missing or damaged connector seals. <li data-bbox="734 1711 1088 1831">2. Place ignition switch in OFF position and disconnect sensor harness from intake manifold temperature sensor. 	<p data-bbox="1107 1312 1453 1375">Clean and repair connector(s) as required (WP 0113 00).</p> <p data-bbox="1107 1512 1453 1638">Remove dirt and moisture from connector. Replace missing or damaged connector seals (WP 0113 00).</p>

Table 4. Error Code 1153 - Intake Air Temperature Sensor Circuit Failure Troubleshooting Procedures - Continued.

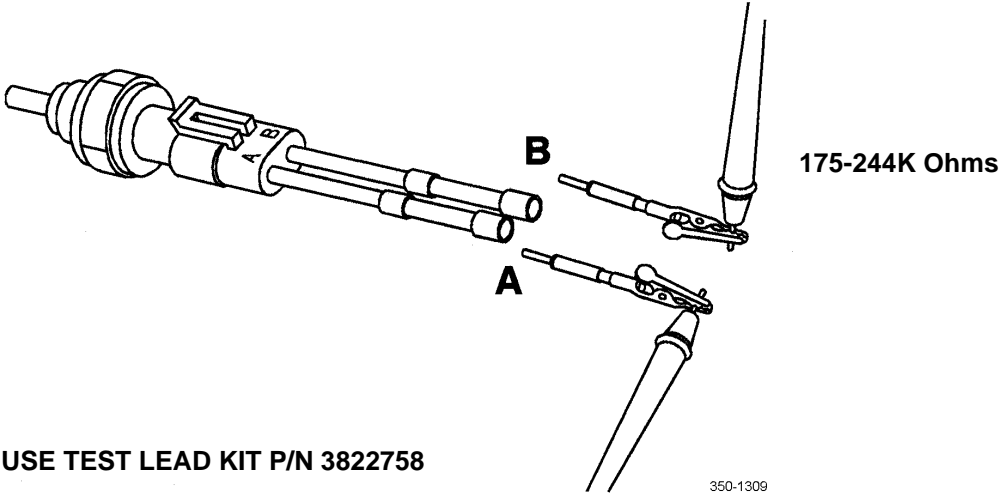
MALFUNCTION	TEST OR INSPECTION	CORRECTIVE ACTION
<p>Error Code 1153 - Intake Air Temperature Sensor Circuit Failure - Continued.</p>	<p>3. Measure resistance from pin A to pin B of coolant temperature sensor. Resistance should be 175 to 244k Ohms.</p>	<p>If resistance is not as specified, replace coolant temperature sensor (WP 0094 00).</p>
<div style="text-align: center;">  <p>USE TEST LEAD KIT P/N 3822758</p> <p>350-1309</p> </div>		
<p>4. Place ignition switch in OFF position and disconnect sensor harness from engine ECU.</p> <p>a. Inspect sensor harness and engine ECU connectors for dirty, corroded, bent, broken, and pushed back or extended pins.</p> <p>b. Check sensor harness and engine ECU for dirt or moisture in or on connectors and for missing or damaged connector seals.</p>		

Table 4. Error Code 1153 - Intake Air Temperature Sensor Circuit Failure Troubleshooting Procedures - Continued.

MALFUNCTION	TEST OR INSPECTION	CORRECTIVE ACTION
<p>Error Code 1153 - Intake Air Temperature Sensor Circuit Failure - Continued.</p>	<p>5. Place ignition switch in OFF position. Disconnect engine harness from intake air temperature sensor and disconnect sensor harness from engine ECU. Perform the following resistance checks:</p> <ul style="list-style-type: none"> a. Measure resistance from pin 38 of sensor harness connector to all other pins in sensor harness. Resistance should be more than 100k Ohms. b. Measure resistance from pin 40 of sensor harness connector to all other pins in sensor harness. Resistance should be more than 100k Ohms. 	<p>If engine harness requires replacement, notify Sustainment Maintenance.</p>

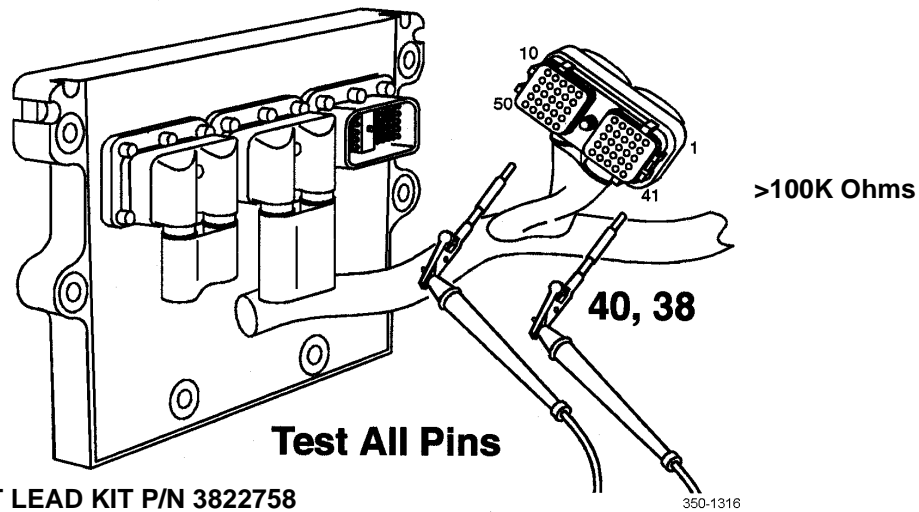
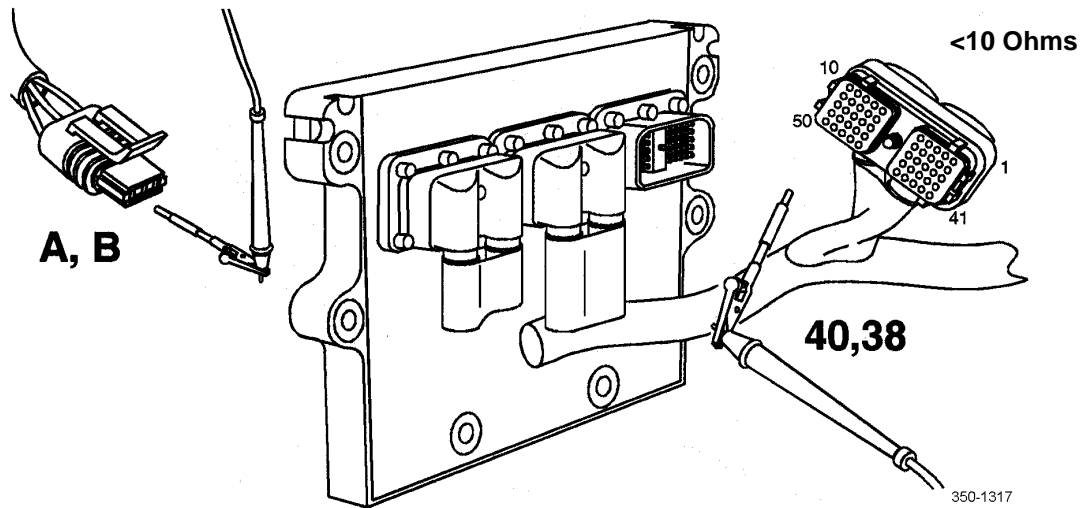



Table 4. Error Code 1153 - Intake Air Temperature Sensor Circuit Failure Troubleshooting Procedures - Continued.

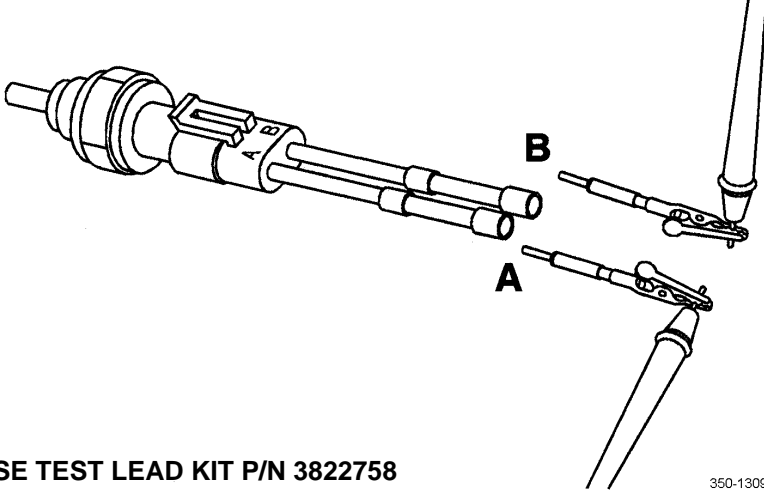
MALFUNCTION	TEST OR INSPECTION	CORRECTIVE ACTION
<p>Error Code 1153 - Intake Air Temperature Sensor Circuit Failure - Continued.</p>	<p>6. Place ignition switch in OFF position. Disconnect engine harness from intake air temperature sensor and disconnect sensor harness from engine ECU. Perform the following resistance checks:</p> <ul style="list-style-type: none"> a. Measure resistance from pin 40 of sensor harness connector to pin 1 (or A) of intake air temperature sensor connector, harness side. Resistance should be less than 10 Ohms. b. Measure resistance from pin 38 of sensor harness connector to pin 2 (or B) of intake air temperature sensor connector, harness side. Resistance should be less than 10 Ohms. 	<p>If engine harness requires replacement, notify Sustainment Maintenance.</p>



USE TEST LEAD KIT P/N 3822758

Table 5. Error Code 1154 - Intake Air Temperature Sensor Circuit Failure Troubleshooting Procedures.

MALFUNCTION	TEST OR INSPECTION	CORRECTIVE ACTION
<p>Error Code 1154 - Intake Air Temperature Sensor Circuit Failure.</p> 	<ol style="list-style-type: none"> 1. Ensure ignition switch is in OFF position. Disconnect sensor harness from intake air temperature sensor. <ol style="list-style-type: none"> a. Inspect intake air temperature sensor and sensor harness connectors for dirty, corroded, bent, broken, and pushed back or extended pins. b. Check intake air temperature sensor and sensor harness for dirt or moisture in or on connectors and for missing or damaged connector seals. 2. Place ignition switch in OFF position and disconnect sensor harness from intake air temperature sensor. 3. Measure resistance from pin A (or 1) to pin B (or 2) of intake air temperature sensor. Resistance should be 175 to 244k Ohms. 	<p>Clean and repair connector(s) as required (WP 0113 00).</p> <p>Remove dirt and moisture from connector. Replace missing or damaged connector seals (WP 0113 00).</p> <p>If resistance is not as specified, replace intake air temperature sensor (WP 0094 00).</p>



175-244K Ohms

USE TEST LEAD KIT P/N 3822758

350-1309

Table 5. Error Code 1154 - Intake Air Temperature Sensor Circuit Failure Troubleshooting Procedures - Continued.

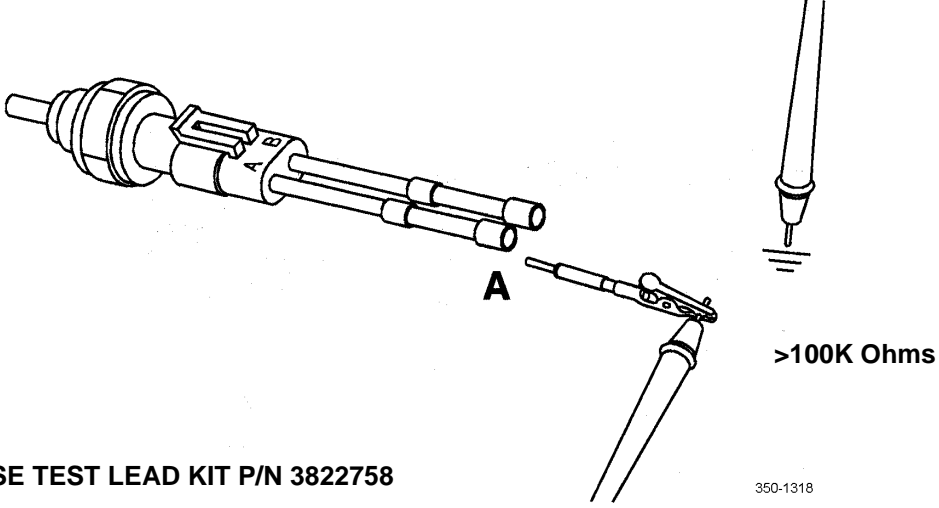
MALFUNCTION	TEST OR INSPECTION	CORRECTIVE ACTION
<p>Error Code 1154 - Intake Air Temperature Sensor Circuit Failure - Continued.</p>	<p>4. Place ignition switch in OFF position and disconnect sensor harness from intake air temperature sensor.</p> <p>5. Measure resistance from pin A of intake air temperature sensor to engine block ground. Resistance should be greater than 100k Ohms.</p>	<p>If resistance is not as specified, replace intake air temperature sensor (WP 0094 00).</p>
 <p>USE TEST LEAD KIT P/N 3822758</p>		
	<p>6. Place ignition switch in OFF position and disconnect sensor harness from engine ECU.</p> <p>a. Inspect sensor harness and engine ECU connectors for dirty, corroded, bent, broken, and pushed back or extended pins.</p> <p>b. Check sensor harness and engine ECU for dirt or moisture in or on connectors and for missing or damaged connector seals.</p>	<p>Clean and repair connector(s) as required (WP 0113 00).</p> <p>Remove dirt and moisture from connector. Replace missing or damaged connector seals (WP 0113 00).</p>

Table 5. Error Code 1154 - Intake Air Temperature Sensor Circuit Failure Troubleshooting Procedures - Continued.

MALFUNCTION	TEST OR INSPECTION	CORRECTIVE ACTION
<p>Error Code 1154 - Intake Air Temperature Sensor Circuit Failure - Continued.</p>	<p>7. Place ignition switch in OFF position. Disconnect sensor harness from intake air temperature sensor and disconnect sensor harness from engine ECU. Perform the following resistance checks:</p> <ul style="list-style-type: none"> a. Measure resistance from pin 40 of sensor harness connector to all other pins in sensor harness. Resistance should be greater than 100k Ohms. b. Measure resistance from pin 38 of sensor harness connector to all other pins in sensor harness. Resistance should be greater than 100k Ohms. 	<p>If engine harness requires replacement, notify Sustainment Maintenance.</p>

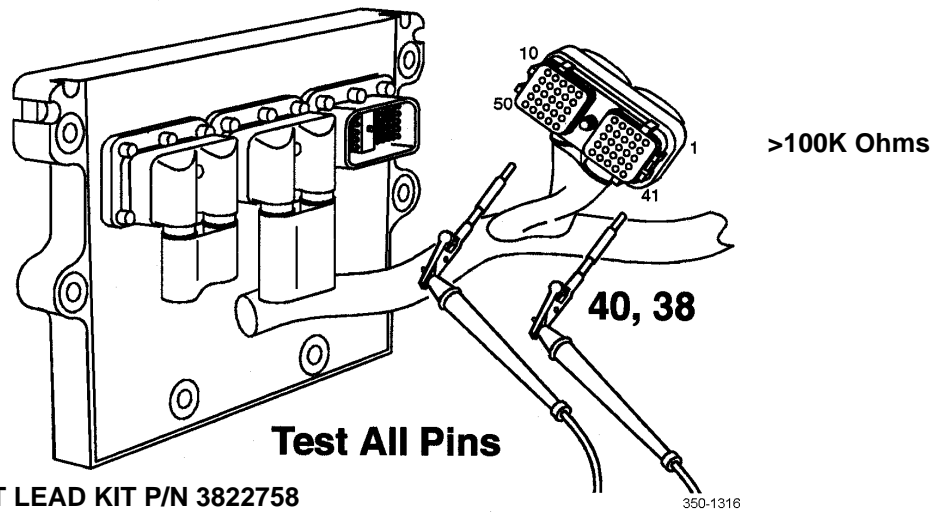


Table 5. Error Code 1154 - Intake Air Temperature Sensor Circuit Failure Troubleshooting Procedures - Continued.

MALFUNCTION	TEST OR INSPECTION	CORRECTIVE ACTION
<p>Error Code 1154 - Intake Air Temperature Sensor Circuit Failure - Continued.</p>	<p>8. Place ignition switch in OFF position. Disconnect sensor harness from intake air temperature sensor and disconnect sensor harness from engine ECU. Perform the following resistance checks:</p> <ul style="list-style-type: none"> a. Measure resistance from pin 40 of sensor harness connector to engine block ground. Resistance should be greater than 100k Ohms. b. Measure resistance from pin 38 of sensor harness connector to engine block ground. Resistance should be greater than 100k Ohms. 	<p>If engine harness requires replacement, notify Sustainment Maintenance.</p>

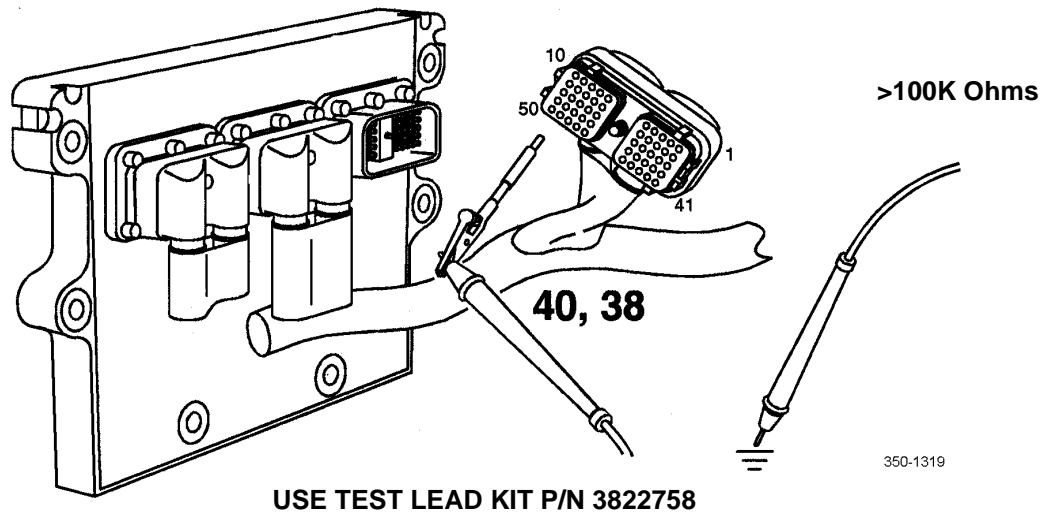


Table 6. Error Code 1155 - Intake Air Temperature Sensor Circuit Failure Troubleshooting Procedures.


MALFUNCTION	TEST OR INSPECTION	CORRECTIVE ACTION
<p data-bbox="159 415 722 472">Error Code 1155 - Intake Air Temperature Sensor Circuit Failure.</p> 	<ol style="list-style-type: none"> <li data-bbox="732 415 1092 472">1. Check coolant level (TM 10-3930-675-10). <li data-bbox="732 493 1092 583">2. Check radiator top and side grille for mud, snow, or obstructions. <li data-bbox="732 661 1092 718">3. Check for loose coolant hoses and clamps. <li data-bbox="732 739 1092 949">4. Enter "DIAG EXTRA FUNCT" 4(13) menu and check water level sensor setting. Enter "0" to shut off and "1" to run cooling fan. Check if fording water level sensor is clogged or damaged. 	<p data-bbox="1102 415 1461 472">Add coolant as required (TM 10-3930-675-10).</p> <p data-bbox="1102 493 1308 520">Clear obstructions.</p> <p data-bbox="1102 661 1430 718">Tighten or replace as required (WP 0065 00).</p> <ol style="list-style-type: none"> <li data-bbox="1102 739 1461 829">a. Clean and/or replace fording water level sensor (WP 0091 00). <li data-bbox="1102 835 1461 892">b. Clean radiator assembly (WP 0219 00).

Table 7. Error Code 1212 - Oil Temperature Sensor Circuit Failure Troubleshooting Procedures.

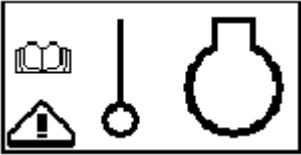
MALFUNCTION	TEST OR INSPECTION	CORRECTIVE ACTION
<p data-bbox="159 1150 722 1207">Error Code 1212 - Oil Temperature Sensor Circuit Failure.</p> 	<ol style="list-style-type: none"> <li data-bbox="732 1150 1092 1297">1. Ensure that ignition switch is in OFF position. Disconnect engine harness from oil pressure/temperature sensor (WP 0094 00). <ol style="list-style-type: none"> <li data-bbox="760 1318 1092 1501">a. Inspect oil pressure/temperature sensor and engine harness connectors for dirty, corroded, bent, broken, and pushed back or extended pins. <li data-bbox="760 1522 1092 1705">b. Check oil pressure/temperature sensor and engine harness for dirt or moisture in or on connectors and for missing or damaged connector seals. <li data-bbox="732 1726 1092 1843">2. Place ignition switch in OFF position and disconnect engine harness from oil pressure/temperature sensor. 	<p data-bbox="1102 1318 1455 1375">Clean and repair connector(s) as required (WP 0113 00).</p> <p data-bbox="1102 1522 1446 1642">Remove dirt and moisture from connector. Replace missing or damaged connector seals (WP 0113 00).</p>

Table 7. Error Code 1212 - Oil Temperature Sensor Circuit Failure Troubleshooting Procedures - Continued.

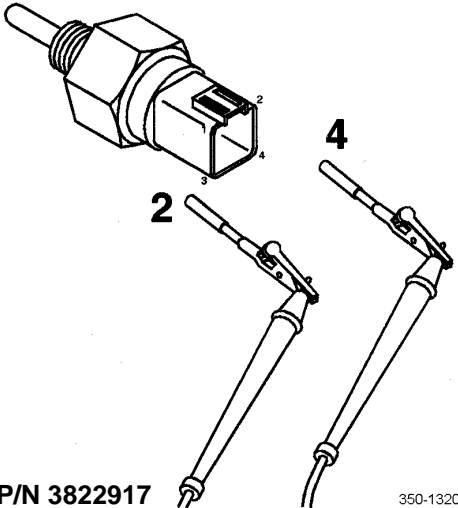
MALFUNCTION	TEST OR INSPECTION	CORRECTIVE ACTION
<p>Error Code 1212 - Oil Temperature Sensor Circuit Failure - Continued.</p>	<p>3. Measure resistance from pin 4 (or D) to pin 2 (or B) of oil pressure/temperature sensor. Resistance should be 300 to 90k Ohms.</p>	<p>If resistance is not as specified, replace oil pressure/temperature sensor (WP 0094 00).</p>
 <p>USE TEST LEAD KIT P/N 3822917</p> <p>350-1320</p> <p>300-90K Ohms</p>		
	<p>4. Place ignition switch in OFF position and disconnect sensor harness from engine ECU.</p> <p>a. Inspect sensor harness and engine ECU connectors for dirty, corroded, bent, broken, and pushed back or extended pins.</p> <p>b. Check sensor harness and engine ECU for dirt or moisture in or on connectors and for missing or damaged connector seals.</p>	<p>Clean and repair connector(s) as required (WP 0113 00).</p> <p>Remove dirt and moisture from connector. Replace missing or damaged connector seals (WP 0113 00).</p>

Table 7. Error Code 1212 - Oil Temperature Sensor Circuit Failure Troubleshooting Procedures - Continued.

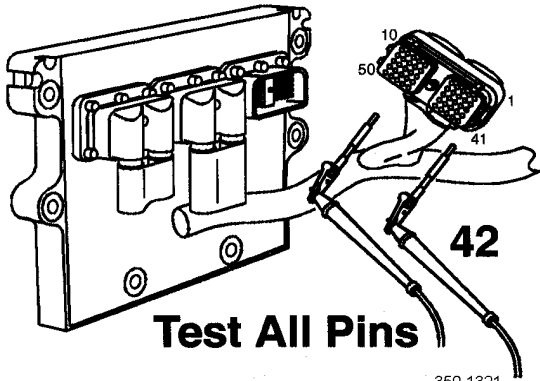
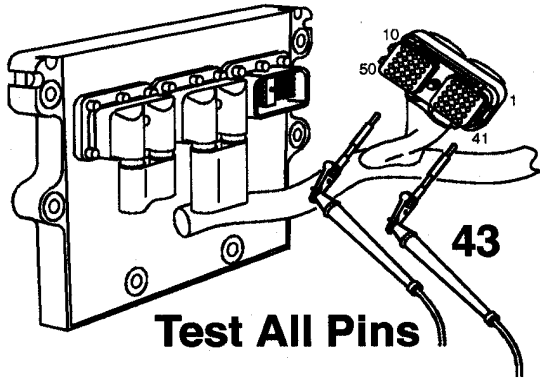
MALFUNCTION	TEST OR INSPECTION	CORRECTIVE ACTION
<p>Error Code 1212 - Oil Temperature Sensor Circuit Failure - Continued.</p>	<p>5. Place ignition switch in OFF position. Disconnect engine harness from oil pressure/temperature sensor and disconnect sensor harness from engine ECU. Perform the following resistance checks:</p> <ul style="list-style-type: none"> a. Measure resistance from pin 42 of sensor harness connector to all other pins in sensor harness. Resistance should be more than 100k Ohms. b. Measure resistance from pin 43 of sensor harness connector to all other pins in sensor harness. Resistance should be more than 100k Ohms. 	<p>If engine harness requires replacement, notify Sustainment Maintenance.</p>
<div style="display: flex; justify-content: space-around;"> <div style="text-align: center;">  <p>Test All Pins</p> <p>>100K Ohms</p> <p><small>350-1321</small></p> </div> <div style="text-align: center;">  <p>Test All Pins</p> <p>>100K Ohms</p> </div> </div>		
	<p>6. Place ignition switch in OFF position. Disconnect engine harness from oil pressure/temperature sensor and disconnect sensor harness from engine ECU. Perform the following resistance checks:</p>	<p>If engine harness requires replacement, notify Sustainment Maintenance.</p>

Table 7. Error Code 1212 - Oil Temperature Sensor Circuit Failure Troubleshooting Procedures - Continued.

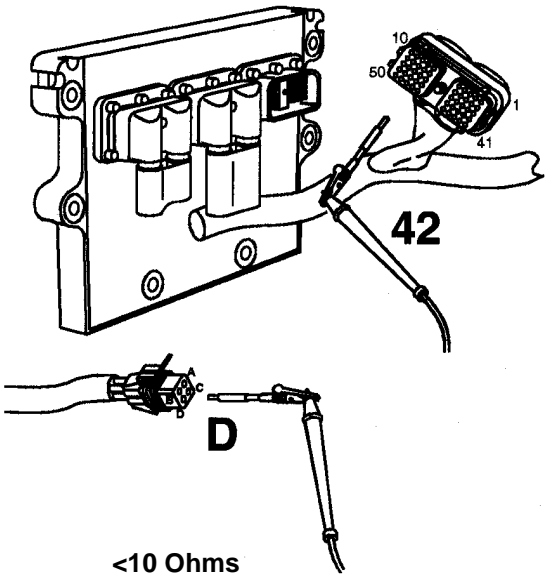
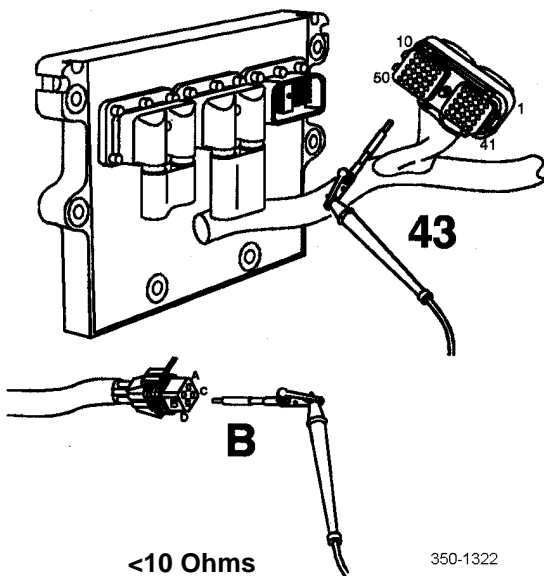

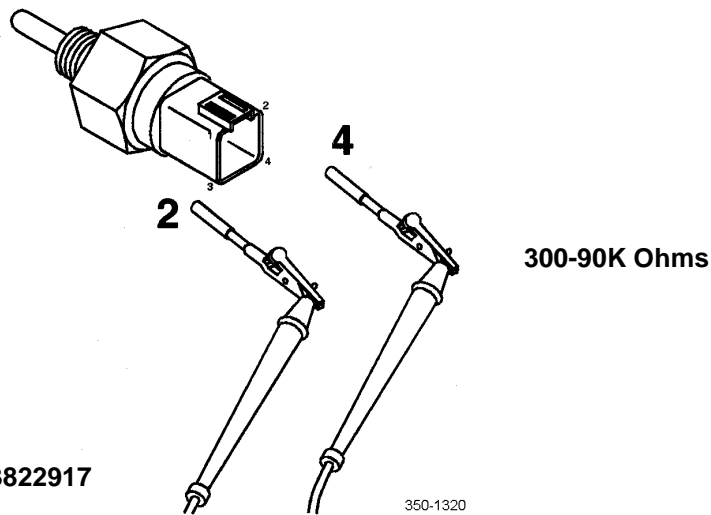
MALFUNCTION	TEST OR INSPECTION	CORRECTIVE ACTION
<p>Error Code 1212 - Oil Temperature Sensor Circuit Failure - Continued.</p>	<p>a. Measure resistance from pin 42 of sensor harness connector to pin 4 (or D) of oil pressure/temperature sensor connector, harness side. Resistance should be less than 10 Ohms.</p> <p>b. Measure resistance from pin 43 of sensor harness connector to pin 2 (or B) of oil pressure/temperature sensor connector, harness side. Resistance should be less than 10 Ohms.</p>	
<p>USE TEST LEAD KIT P/N 3822758</p>		
<div style="display: flex; justify-content: space-around;"> <div style="text-align: center;">  <p>D</p> <p><10 Ohms</p> </div> <div style="text-align: center;">  <p>B</p> <p><10 Ohms</p> </div> </div> <p style="text-align: right; margin-right: 50px;">350-1322</p>		

Table 8. Error Code 1213 - Oil Temperature Sensor Circuit Failure Troubleshooting Procedures.

MALFUNCTION	TEST OR INSPECTION	CORRECTIVE ACTION
<p>Error Code 1213 - Oil Temperature Sensor Circuit Failure.</p> 	<ol style="list-style-type: none"> 1. Ensure ignition switch is in OFF position. Disconnect engine harness from oil pressure/temperature sensor (WP 0094 00). <ol style="list-style-type: none"> a. Inspect oil temperature sensor and engine harness connectors for dirty, corroded, bent, broken, and pushed back or extended pins. b. Check oil temperature sensor and engine harness for dirt or moisture in or on the connectors and for missing or damaged connector seals. 2. Place ignition switch in OFF position and disconnect engine harness from oil pressure/temperature sensor. 3. Measure resistance from pin 4 (or D) to pin 2 (or B) of oil pressure/temperature sensor. Resistance should be 300 to 90k Ohms. 	<p>Clean and repair connector(s) as required (WP 0113 00).</p> <p>Remove dirt and moisture from connector. Replace missing or damaged connector seals (WP 0113 00).</p> <p>If resistance is not as specified, replace oil pressure/temperature sensor (WP 0094 00).</p>



USE TEST LEAD KIT P/N 3822917

350-1320

Table 8. Error Code 1213 - Oil Temperature Sensor Circuit Failure Troubleshooting Procedures - Continued.

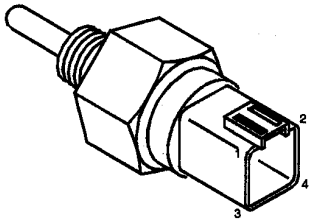
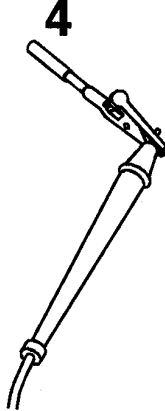
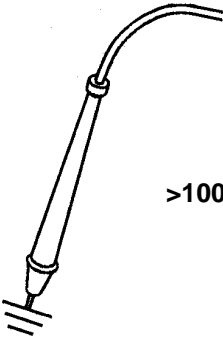
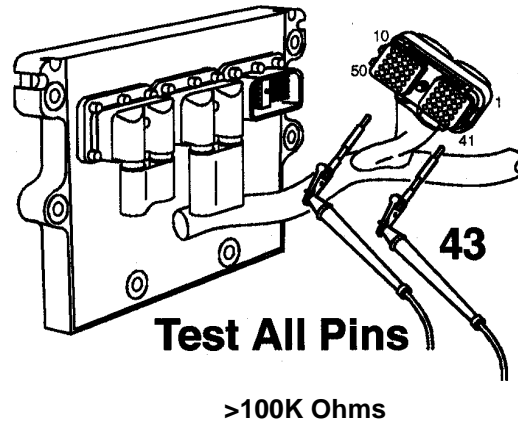
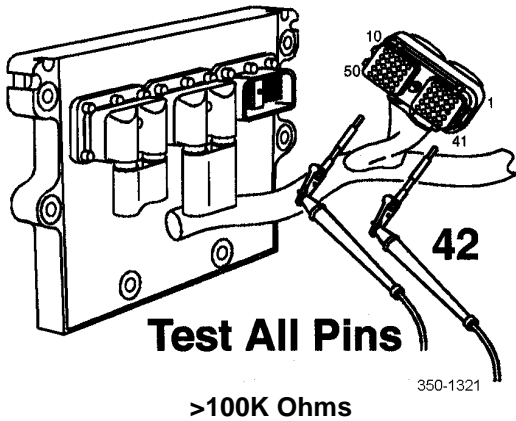
MALFUNCTION	TEST OR INSPECTION	CORRECTIVE ACTION
<p>Error Code 1213 - Oil Temperature Sensor Circuit Failure - Continued.</p>	<p>4. Place ignition switch in OFF position and disconnect engine harness from oil pressure/temperature sensor.</p> <p>5. Measure resistance from pin 4 (or D) of oil pressure/temperature sensor to engine block ground. Resistance should be greater than 100k Ohms.</p>	<p>If resistance is not as specified, replace oil pressure/temperature sensor (WP 0094 00).</p>
<div style="display: flex; justify-content: space-around; align-items: center;">    </div> <p data-bbox="203 1310 625 1339">USE TEST LEAD KIT P/N 3822917</p> <p data-bbox="1123 1318 1192 1339">350-1323</p>		
	<p>6. Place ignition switch in OFF position. Disconnect engine harness from oil pressure/temperature sensor and disconnect sensor harness connector from engine ECU. Perform the following resistance checks.</p>	<p>If engine harness requires replacement, notify Sustainment Maintenance.</p>

Table 8. Error Code 1213 - Oil Temperature Sensor Circuit Failure Troubleshooting Procedures - Continued.

MALFUNCTION	TEST OR INSPECTION	CORRECTIVE ACTION
<p>Error Code 1213 - Oil Temperature Sensor Circuit Failure - Continued.</p>	<p>a. Measure resistance from pin 42 of sensor harness connector to all other pins in connector. Resistance should be greater than 100k Ohms.</p> <p>b. Measure resistance from pin 43 of sensor harness connector to all other pins in connector. Resistance should be greater than 100k Ohms.</p>	

USE TEST LEAD KIT P/N 3822758



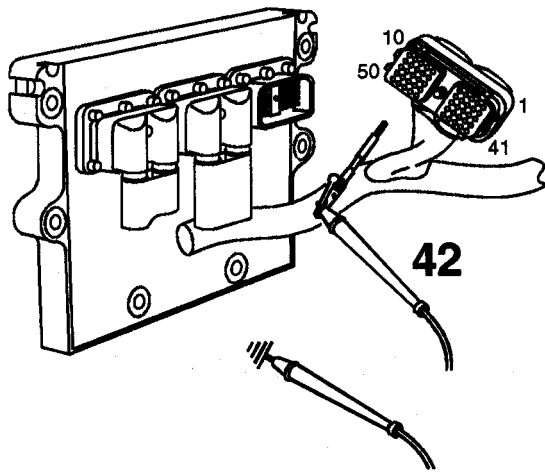
7. Place ignition switch in OFF position. Disconnect engine harness from oil pressure/temperature sensor and disconnect sensor harness connector from engine ECU. Perform the following resistance checks.

If engine harness requires replacement, notify Sustainment Maintenance.

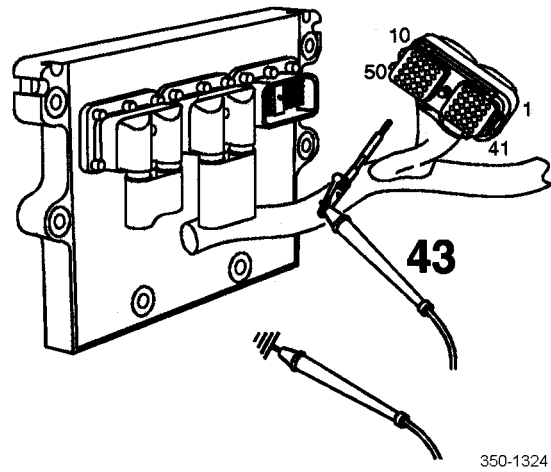
Table 8. Error Code 1213 - Oil Temperature Sensor Circuit Failure Troubleshooting Procedures - Continued.

MALFUNCTION	TEST OR INSPECTION	CORRECTIVE ACTION
<p>Error Code 1213 - Oil Temperature Sensor Circuit Failure - Continued.</p>	<p>a. Measure resistance from pin 42 of sensor harness connector to engine block ground. Resistance should be greater than 100k Ohms.</p> <p>b. Measure resistance from pin 43 of sensor harness connector to engine block ground. Resistance should be greater than 100k Ohms.</p>	

USE TEST LEAD KIT P/N 3822758



>100K Ohms



>100K Ohms

350-1324

Table 9. Error Code 1214 - Oil Temperature Sensor Circuit Failure Troubleshooting Procedures.

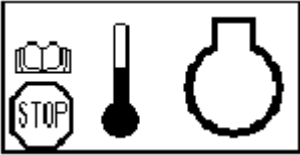
MALFUNCTION	TEST OR INSPECTION	CORRECTIVE ACTION
<p>Error Code 1214 - Oil Temperature Sensor Circuit Failure.</p> 	<ol style="list-style-type: none"> 1. Check coolant level (TM 10-3930-675-10). 2. Check radiator top and side grille for mud, snow, or obstructions. 3. Check for loose coolant hoses and clamps. 4. Enter "DIAG EXTRA FUNCT" 4(13) menu and check water level sensor setting. Enter "0" to shut off and "1" to run cooling fan. Check if fording water level sensor is clogged or damaged. 	<p>Add coolant as required (TM 10-3930-675-10).</p> <p>Clear obstructions.</p> <p>Tighten or replace as required (WP 0065 00).</p> <ol style="list-style-type: none"> a. Clean and/or replace fording water level sensor (WP 0091 00). b. If problem continues, notify Sustainment Maintenance.

Table 10. Error Code 1697 - ECU Internal Temperature Sensor Circuit Failure Troubleshooting Procedures.



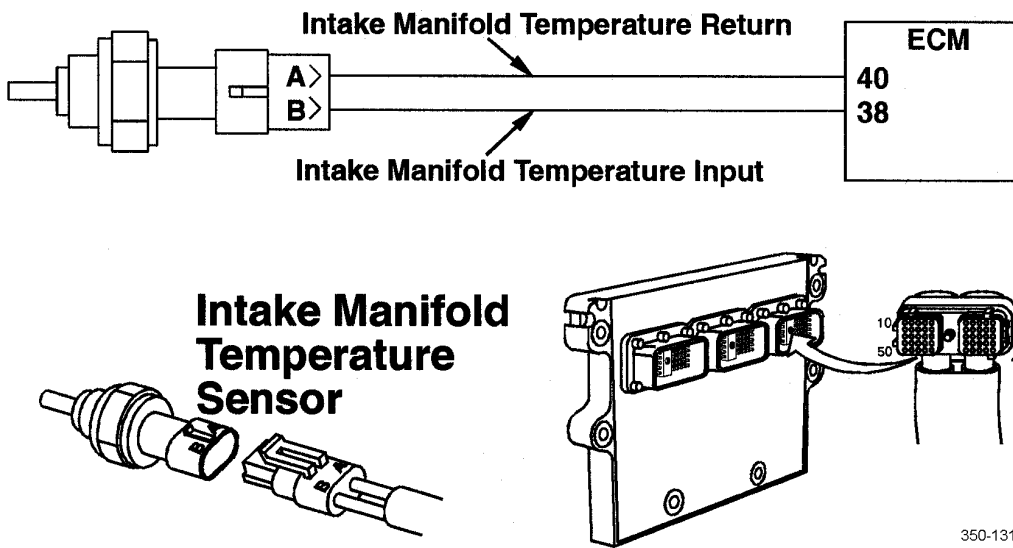
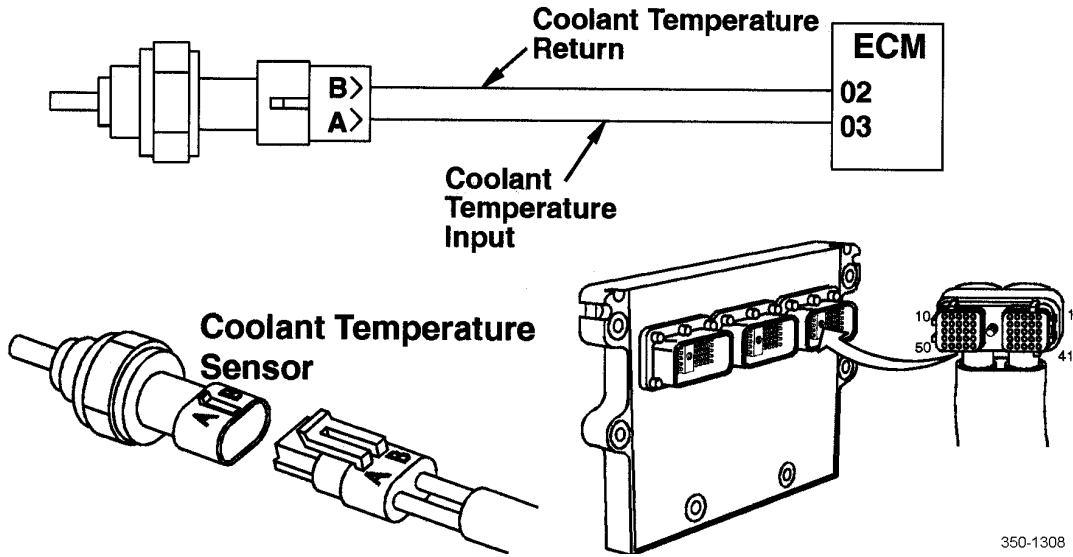
MALFUNCTION	TEST OR INSPECTION	CORRECTIVE ACTION
<p>Error Code 1697 - ECU Internal Temperature Sensor Circuit Failure.</p> 		<p>Notify SRA.</p>

Table 11. Error Code 1698 - ECU Internal Temperature Sensor Circuit Failure Troubleshooting Procedures.

MALFUNCTION	TEST OR INSPECTION	CORRECTIVE ACTION
<p>Error Code 1698 - ECU Internal Temperature Sensor Circuit Failure.</p> 		<p>Notify SRA.</p>

NOTE

Location of engine sensors is illustrated in WP 0094 00.



END OF WORK PACKAGE

THIS WORK PACKAGE COVERS

Error Code 1221 - High Voltage Detected at Ambient Air Pressure Sensor Circuit

Error Code 1295 - Ambient Air Pressure Sensor Circuit Failure

Error Code 1222 - Low Voltage Detected at Ambient Air Pressure Sensor Circuit

Error Code 1298 - High Intake Air Restriction or Circuit Failure

INITIAL SETUP

Tools and Special Tools

- Test Lead, Female (Item 121, WP 0289 00)
- Test Lead, Male (Item 124, WP 0289 00)

References

TM 10-3930-675-10

NOTE

- Refer to WP 0004 00 for additional troubleshooting guidance, information, and illustrations that locate critical components.
- Refer also to illustration at end of work package for component location.
- Ambient air pressure sensor is mounted to bracket on left side of engine, to right rear of engine ECU.

Table 1. Error Code 1221 - High Voltage Detected at Ambient Air Pressure Sensor Circuit Troubleshooting Procedures.


MALFUNCTION	TEST OR INSPECTION	CORRECTIVE ACTION
<p>Error Code 1221 - High Voltage Detected at Ambient Air Pressure Sensor Circuit.</p> 	<ol style="list-style-type: none"> 1. Ensure ignition switch is in OFF position and disconnect engine harness from ambient air pressure sensor. 2. Inspect ambient air pressure sensor and sensor harness connectors for dirty, corroded, bent, broken, pushed back, and extended pins. 3. Check ambient air pressure sensor and sensor harness for dirt or moisture in or on connector and for missing or damaged connector seals. 	<p>Clean and repair connector(s) as required (WP 0113 00).</p> <p>Remove dirt and moisture from connector. Replace missing or damaged connector seals (WP 0113 00).</p>

Table 1. Error Code 1221 - High Voltage Detected at Ambient Air Pressure Sensor Circuit Troubleshooting Procedures - Continued.

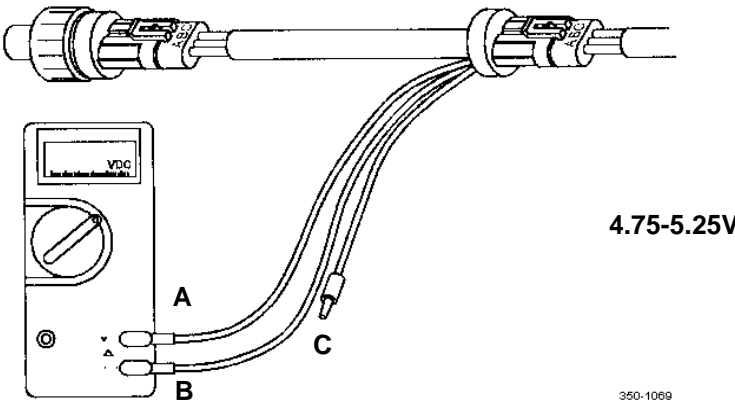
MALFUNCTION	TEST OR INSPECTION	CORRECTIVE ACTION
<p>Error Code 1221 - High Voltage Detected at Ambient Air Pressure Sensor Circuit - Continued.</p>	<p>4. Install breakout cable between sensor and sensor harness connector. Place ignition switch in ON and measure supply voltage from pin A to pin B of breakout cable. Voltage should be 4.75 to 5.25V.</p>	<p>If voltage is not as specified, proceed with the following steps.</p>
		
	<p>5. Disconnect sensor harness connector from ECU and place ignition switch in ON position. Measure voltage at ECU sensor port from pin 17 to pin 31 of ECU sensor port. Voltage should be 4.75 to 5.25V.</p>	<p>a. If engine harness requires replacement, notify Sustainment Maintenance. b. If voltage is not as specified, replace engine ECU (WP 0080 00).</p>

Table 1. Error Code 1221 - High Voltage Detected at Ambient Air Pressure Sensor Circuit Troubleshooting Procedures - Continued.

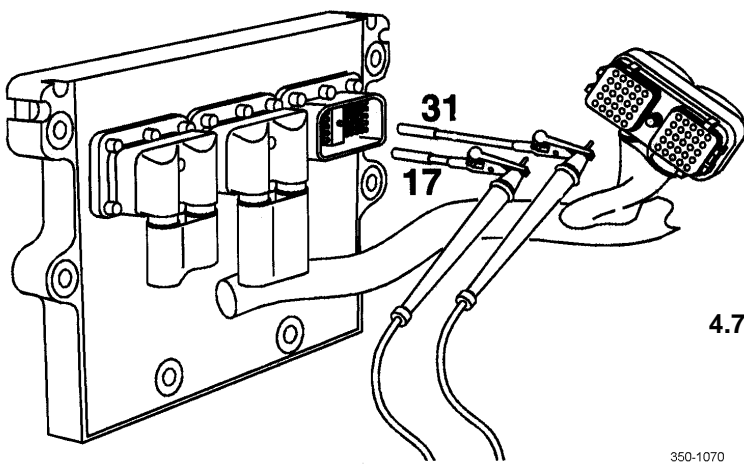
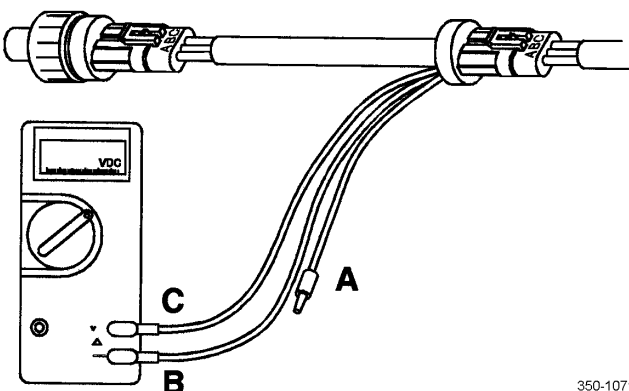
MALFUNCTION	TEST OR INSPECTION	CORRECTIVE ACTION												
<p>Error Code 1221 - High Voltage Detected at Ambient Air Pressure Sensor Circuit - Continued.</p> <p>USE TEST LEAD KIT P/N 3822917</p>  <p>350-1070</p>	<p>6. Install breakout cable between sensor and sensor harness connector and place ignition switch in ON position. Measure signal voltage from pin C to pin B of breakout cable. Voltage should be as follows:</p> <table border="1" data-bbox="771 1239 1047 1417"> <thead> <tr> <th colspan="2"><u>Altitude (Ft.) vs. Voltage</u></th> </tr> </thead> <tbody> <tr> <td>0</td> <td>= 3.4 to 4.5V</td> </tr> <tr> <td>3K</td> <td>= 2.8 to 3.8V</td> </tr> <tr> <td>6K</td> <td>= 2.2 to 3.2V</td> </tr> <tr> <td>9K</td> <td>= 1.7 to 2.7V</td> </tr> <tr> <td>12K</td> <td>= 1.2 to 2.2V</td> </tr> </tbody> </table>  <p>350-1071</p>	<u>Altitude (Ft.) vs. Voltage</u>		0	= 3.4 to 4.5V	3K	= 2.8 to 3.8V	6K	= 2.2 to 3.2V	9K	= 1.7 to 2.7V	12K	= 1.2 to 2.2V	<p>If voltage is not as specified, proceed with the following steps.</p>
<u>Altitude (Ft.) vs. Voltage</u>														
0	= 3.4 to 4.5V													
3K	= 2.8 to 3.8V													
6K	= 2.2 to 3.2V													
9K	= 1.7 to 2.7V													
12K	= 1.2 to 2.2V													

Table 1. Error Code 1221 - High Voltage Detected at Ambient Air Pressure Sensor Circuit Troubleshooting Procedures - Continued.

MALFUNCTION	TEST OR INSPECTION	CORRECTIVE ACTION
<p>Error Code 1221 - High Voltage Detected at Ambient Air Pressure Sensor Circuit - Continued.</p>	<ol style="list-style-type: none"> 7. Place ignition switch in OFF position and disconnect sensor harness connector from ECU. 8. Inspect sensor harness and ECU connector for dirty, corroded, bent, broken, pushed back, and extended pins. 9. Check sensor harness and ECU for dirt or moisture in or on connector and for missing or damaged connector seals. 10. Place ignition switch in OFF position and disconnect sensor harness connector from ECU. 11. Measure resistance from pin 6 of sensor harness connector to all other pins in the connector. Resistance should be greater than 100k Ohms. 	<p>Clean and repair connector(s) as required (WP 0113 00).</p> <p>Remove dirt and moisture from connector. Replace missing or damaged connector seals (WP 0113 00).</p> <p>If engine harness requires replacement, notify Sustainment Maintenance.</p>

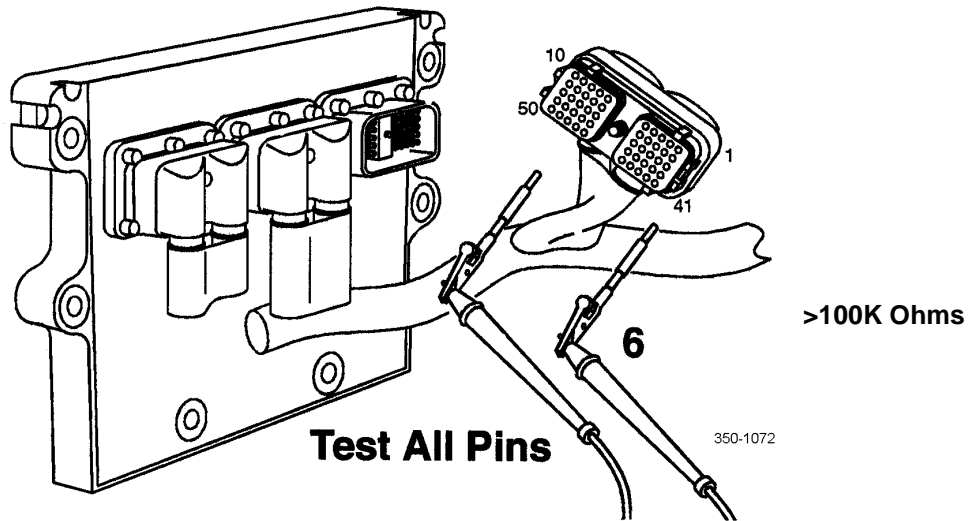
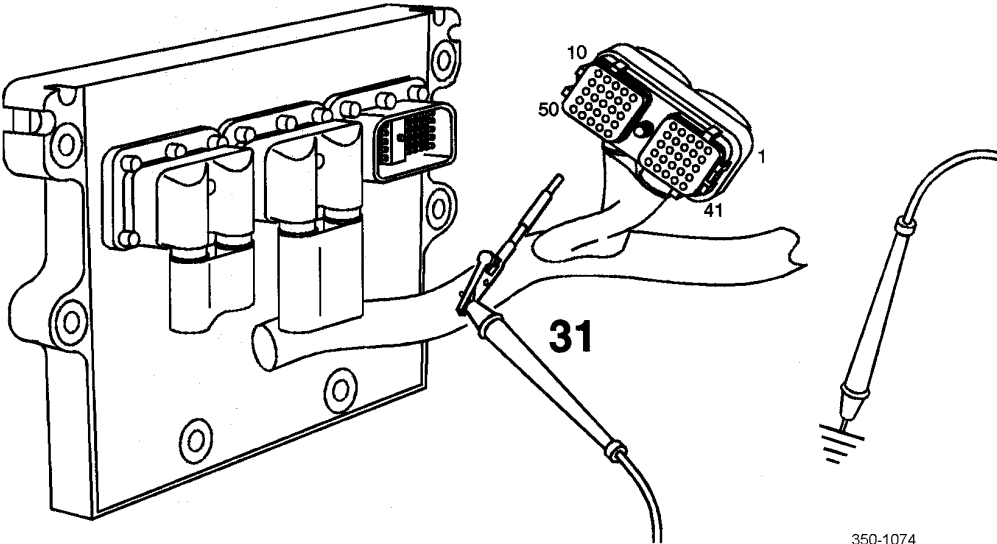


Table 1. Error Code 1221 - High Voltage Detected at Ambient Air Pressure Sensor Circuit Troubleshooting Procedures - Continued.

MALFUNCTION	TEST OR INSPECTION	CORRECTIVE ACTION
<p>Error Code 1221 - High Voltage Detected at Ambient Air Pressure Sensor Circuit - Continued.</p>	<p>12. Place ignition switch in OFF position and disconnect sensor harness connector from ECU and disconnect engine harness from ambient air pressure sensor.</p> <p>13. Check for open circuit in return wire by measuring resistance from pin 31 of sensor harness connector to engine block ground. Resistance should be less than 10 Ohms.</p>	<p>Clean and repair connector(s) as required (WP 0113 00).</p> <p>a. If resistance is as specified, replace ambient air pressure sensor (WP 0094 00).</p> <p>b. If engine harness requires replacement, notify Sustainment Maintenance.</p>



<math><10\text{ Ohms}</math>

350-1074

Table 2. Error Code 1222 - Low Voltage Detected at Ambient Air Pressure Sensor Circuit Troubleshooting Procedures.


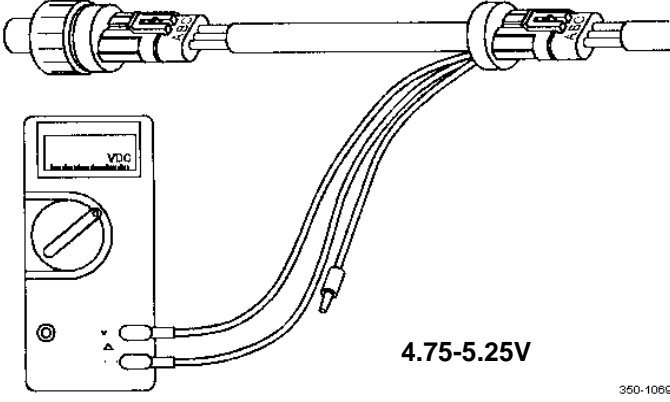
MALFUNCTION	TEST OR INSPECTION	CORRECTIVE ACTION
<p data-bbox="159 443 719 499">Error Code 1222 - Low Voltage Detected at Ambient Air Pressure Sensor Circuit.</p> 	<ol style="list-style-type: none"> <li data-bbox="732 443 1088 562">1. Ensure ignition switch is in OFF position and disconnect engine harness from ambient air pressure sensor. <li data-bbox="732 583 1088 772">2. Inspect ambient air pressure sensor and sensor harness connectors for dirty, corroded, bent, broken, pushed back, and extended pins. <li data-bbox="732 793 1088 947">3. Check ambient air pressure sensor and sensor harness for dirt or moisture in or on connector and for missing or damaged connector seals. <li data-bbox="732 968 1088 1213">4. Install breakout cable between sensor and sensor harness connector. Place ignition switch in ON position and measure supply voltage from pin A to pin B of breakout cable. Voltage should be 4.75 to 5.25V. 	<p data-bbox="1104 583 1453 646">Clean and repair connector(s) as required (WP 0113 00).</p> <p data-bbox="1104 793 1453 919">Remove dirt and moisture from connector. Replace missing or damaged connector seals (WP 0113 00).</p> <p data-bbox="1104 968 1453 1031">If voltage is not as specified, proceed with the following steps.</p>
 <p data-bbox="873 1627 1006 1654">4.75-5.25V</p> <p data-bbox="1096 1669 1144 1690">350-1089</p>		

Table 2. Error Code 1222 - Low Voltage Detected at Ambient Air Pressure Sensor Circuit Troubleshooting Procedures - Continued.

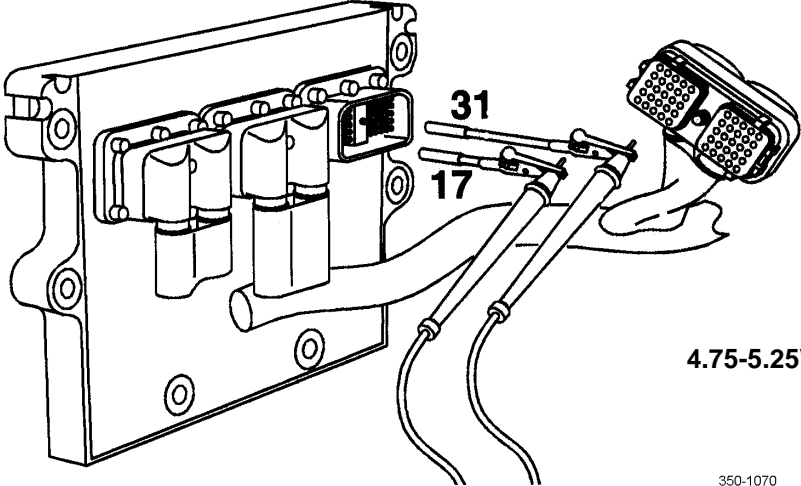
MALFUNCTION	TEST OR INSPECTION	CORRECTIVE ACTION
<p>Error Code 1222 - Low Voltage Detected at Ambient Air Pressure Sensor Circuit - Continued.</p>	<p>5. Disconnect sensor harness connector from ECU and place ignition switch in ON position. Measure voltage at ECU sensor port from pin 17 to pin 31 of ECU sensor port. Voltage should be 4.75 to 5.25V.</p>	<p>If voltage is not as specified, proceed with the following steps.</p>
<p>USE TEST LEAD KIT P/N 3822917</p>  <p>31 17</p> <p>4.75-5.25V</p> <p>350-1070</p>		

Table 2. Error Code 1222 - Low Voltage Detected at Ambient Air Pressure Sensor Circuit Troubleshooting Procedures - Continued.

MALFUNCTION	TEST OR INSPECTION	CORRECTIVE ACTION															
<p>Error Code 1222 - Low Voltage Detected at Ambient Air Pressure Sensor Circuit - Continued.</p>	<p>6. Install breakout cable between sensor and sensor harness connector and place ignition switch in ON position. Measure signal voltage from pin C to pin B of breakout cable. Voltage should be as follows:</p> <p><u>Altitude (Ft.) vs. Voltage</u></p> <table border="0"> <tr> <td>0</td> <td>=</td> <td>3.4 to 4.5V</td> </tr> <tr> <td>3K</td> <td>=</td> <td>2.8 to 3.8V</td> </tr> <tr> <td>6K</td> <td>=</td> <td>2.2 to 3.2V</td> </tr> <tr> <td>9K</td> <td>=</td> <td>1.7 to 2.7V</td> </tr> <tr> <td>12K</td> <td>=</td> <td>1.2 to 2.2V</td> </tr> </table>	0	=	3.4 to 4.5V	3K	=	2.8 to 3.8V	6K	=	2.2 to 3.2V	9K	=	1.7 to 2.7V	12K	=	1.2 to 2.2V	<p>If voltage is not as specified, proceed with the following steps.</p>
0	=	3.4 to 4.5V															
3K	=	2.8 to 3.8V															
6K	=	2.2 to 3.2V															
9K	=	1.7 to 2.7V															
12K	=	1.2 to 2.2V															
	<div data-bbox="483 926 1156 1339" data-label="Diagram"> </div> <p>350-1071</p> <p>7. Place ignition switch in OFF position and disconnect ambient air pressure sensor from engine harness. Disconnect sensor harness connector from ECU.</p> <p>8. Measure resistance from pin 6 of sensor harness connector to chassis ground. Measurement should be greater than 100k Ohms.</p>	<p>If measurement is not as specified, notify Sustainment Maintenance to replace engine harness.</p>															

Table 2. Error Code 1222 - Low Voltage Detected at Ambient Air Pressure Sensor Circuit Troubleshooting Procedures - Continued.

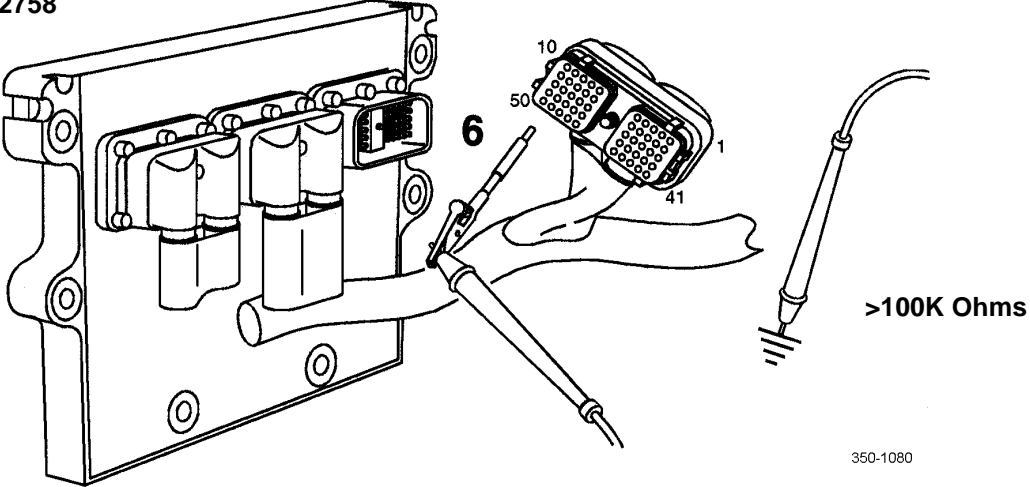
MALFUNCTION	TEST OR INSPECTION	CORRECTIVE ACTION
<p>Error Code 1222 - Low Voltage Detected at Ambient Air Pressure Sensor Circuit - Continued.</p> <p>USE TEST LEAD KIT P/N 3822758</p> 	<p>9. Place ignition switch in OFF position. Disconnect engine harness from ambient air pressure sensor and disconnect sensor harness connector from engine ECU.</p>	

Table 2. Error Code 1222 - Low Voltage Detected at Ambient Air Pressure Sensor Circuit Troubleshooting Procedures - Continued.

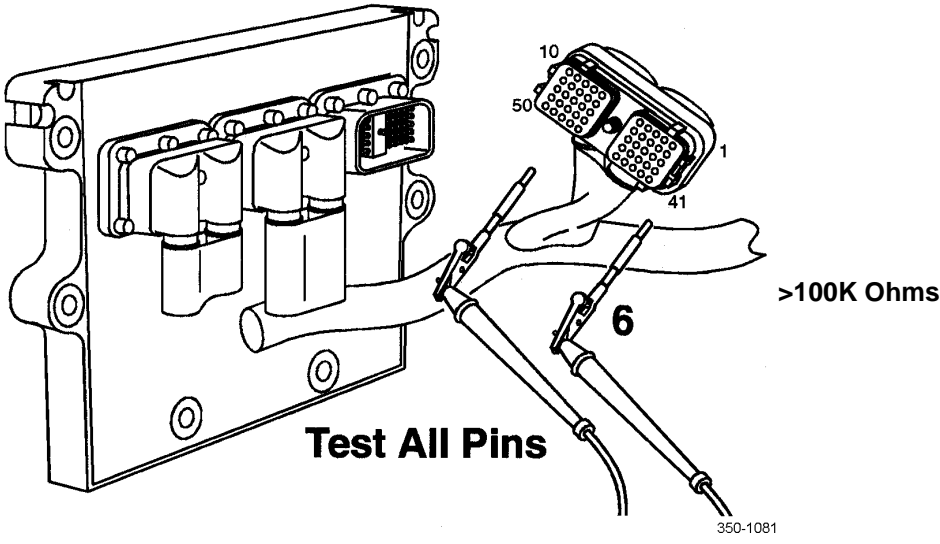
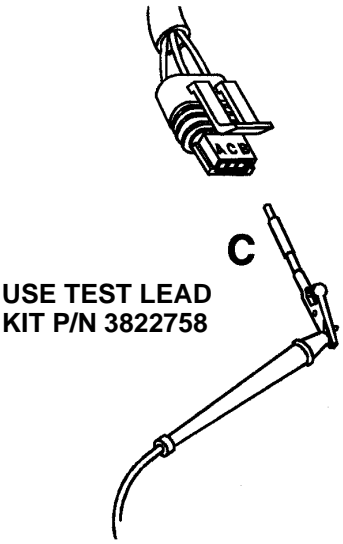
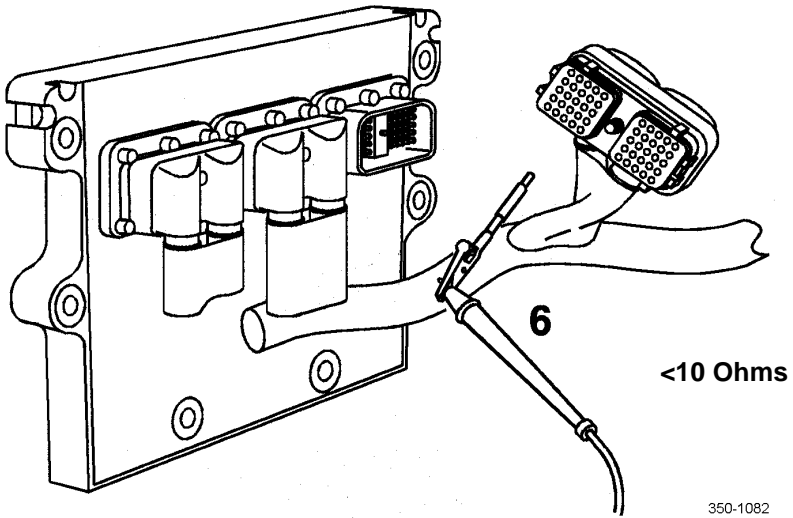
MALFUNCTION	TEST OR INSPECTION	CORRECTIVE ACTION
<p>Error Code 1222 - Low Voltage Detected at Ambient Air Pressure Sensor Circuit - Continued.</p>	<p>10. Measure resistance from pin 6 of sensor harness connector to all other pins in connector. Resistance should be greater than 100k Ohms.</p>	<p>a. If resistance is as specified, replace ambient air pressure sensor (WP 0092 00). b. If engine harness requires replacement, notify Sustainment Maintenance.</p>
<p>USE TEST LEAD KIT P/N 3822758</p>  <p style="text-align: center;">Test All Pins</p> <p style="text-align: right;">350-1081</p>		
	<p>11. Place ignition switch in OFF position. Disconnect sensor harness connector from ECU.</p> <p>12. Inspect sensor harness and ECU connectors for dirty, corroded, bent, broken, pushed back, and extended pins.</p> <p>13. Check sensor harness and ECU for dirt or moisture in or on connector and for missing or damaged connector seals.</p>	<p>Clean and repair connector(s) as required (WP 0113 00).</p> <p>Remove dirt and moisture from connector. Replace missing or damaged connector seals (WP 0113 00).</p>

Table 2. Error Code 1222 - Low Voltage Detected at Ambient Air Pressure Sensor Circuit Troubleshooting Procedures - Continued.

MALFUNCTION	TEST OR INSPECTION	CORRECTIVE ACTION
<p>Error Code 1222 - Low Voltage Detected at Ambient Air Pressure Sensor Circuit - Continued.</p> 	<p>14. Place ignition switch in OFF position. Disconnect ambient air pressure sensor. Disconnect ECU sensor harness connector. Measure resistance from sensor harness connector pin 6 to ambient air pressure sensor signal pin C. Measurement should be less than 10 Ohms.</p> 	<p>If engine harness requires replacement, notify Sustainment Maintenance.</p>
	<p>15. Disconnect sensor harness connector from ECU and place ignition switch in ON position.</p>	

ENGINE AMBIENT AIR PRESSURE SENSOR AND CIRCUITS TROUBLESHOOTING - CONTINUED 0022 00

Table 2. Error Code 1222 - Low Voltage Detected at Ambient Air Pressure Sensor Circuit Troubleshooting Procedures - Continued.

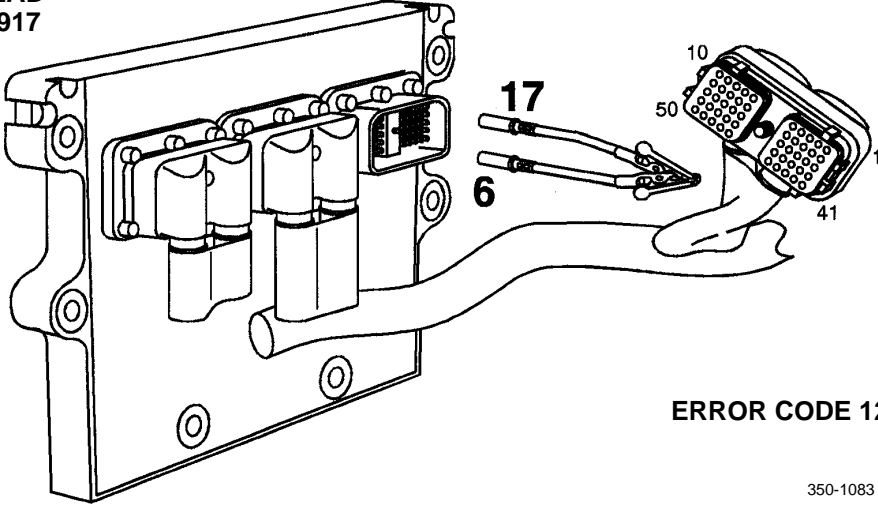
MALFUNCTION	TEST OR INSPECTION	CORRECTIVE ACTION
<p>Error Code 1222 - Low Voltage Detected at Ambient Air Pressure Sensor Circuit - Continued.</p> <p>USE TEST LEAD KIT P/N 3822917</p>  <p>ERROR CODE 1221</p> <p>350-1083</p>	<p>16. Install jumper wire between ECU sensor port pin 6 and pin 17. Check error code display. Error code 1221 should be displayed.</p>	<p>If error code 1222 is displayed, replace engine ECU (WP 0079 00).</p>

Table 3. Error Code 1295 - Ambient Air Pressure Sensor Circuit Failure Troubleshooting Procedures.



MALFUNCTION	TEST OR INSPECTION	CORRECTIVE ACTION
<p data-bbox="160 413 717 472">Error Code 1295 - Ambient Air Pressure Sensor Circuit Failure.</p> 	<p data-bbox="730 413 1089 506">Perform Troubleshooting procedure for error codes 1221 and 1222 in this work package.</p>	

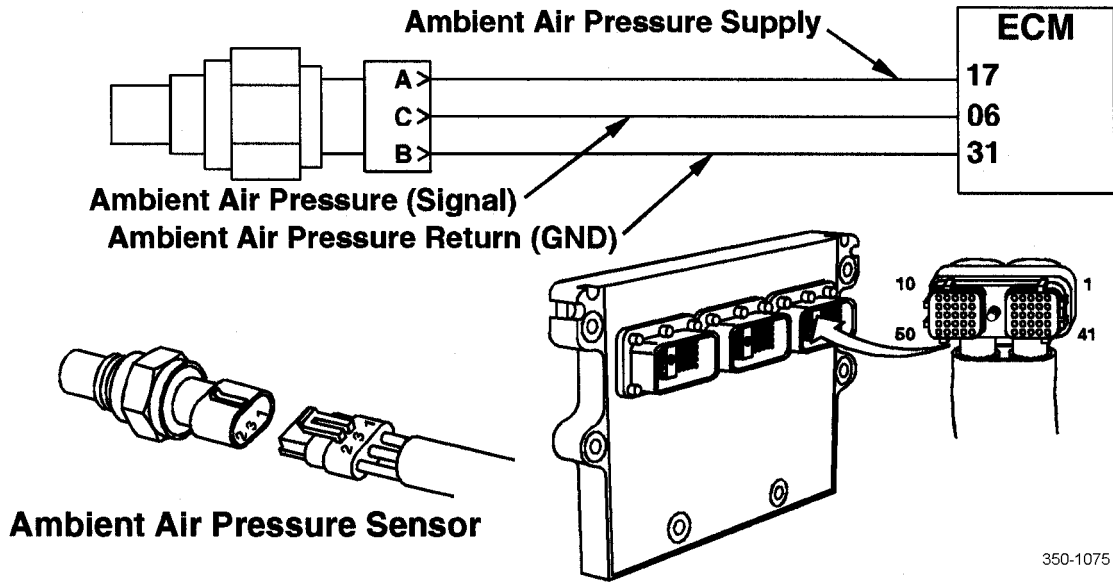
Table 4. Error Code 1298 - High Intake Air Restriction or Circuit Failure (RESET or USMC Only) Troubleshooting Procedures.

MALFUNCTION	TEST OR INSPECTION	CORRECTIVE ACTION
<p data-bbox="160 903 717 961">Error Code 1298 - High Intake Air Restriction or Circuit Failure (RESET or USMC Only).</p> 	<ol style="list-style-type: none"> <li data-bbox="730 903 1089 1029">1. Check air filter restriction indicator for restriction indication (TM 10-3930-675-10). <li data-bbox="730 1218 1089 1375">2. Locate the air pressure sensor (754) on the intake pipe crossing over the engine valve cover. Inspect sensor for damage and connection. <li data-bbox="730 1396 1089 1606">3. Check for continuity. Disconnect the air pressure sensor and check continuity between the two pins of the sensor. There should be continuity when the engine is not running. <li data-bbox="730 1627 1089 1879">4. Follow the harness of the sensor down the side of the engine block to the connector where the sensor joins the engine harness (switched output A connector). Inspect connector for connection or damage. 	<p data-bbox="1102 903 1456 1029">If air filter indicator is tripped or indicates a restriction of 20 in. water column or more, service or replace the air filter element.</p> <p data-bbox="1047 1039 1144 1081" style="text-align: center;">NOTE</p> <p data-bbox="779 1092 1412 1186">If the intake air restriction is at or above 20 in. water column the engine will de-rate to 1,000 RPM and activate ERROR CODE 1298.</p> <ol style="list-style-type: none"> <li data-bbox="1102 1218 1461 1270">a. Reconnect disconnected sensor. <li data-bbox="1102 1281 1461 1333">b. Replace damaged air pressure sensor (WP 0094 00). <p data-bbox="1102 1396 1445 1512">If air pressure sensor does not have continuity, replace air pressure sensor (754) (WP 0094 00).</p> <p data-bbox="1102 1627 1396 1690">Repair or replace damaged connector (WP 0113 00).</p>

ENGINE AMBIENT AIR PRESSURE SENSOR AND CIRCUITS TROUBLESHOOTING - CONTINUED 0022 00

Table 4. Error Code 1298 - High Intake Air Restriction or Circuit Failure (RESET or USMC Only) Troubleshooting Procedures - Continued.

MALFUNCTION	TEST OR INSPECTION	CORRECTIVE ACTION
<p>Error Code 1298 - High Intake Air Restriction or Circuit Failure (RESET or USMC Only) - Continued.</p>	<p>5. Check continuity of the two wires between the air pressure sensor harness connector and the switched output A connector (pins 1 and 3).</p> <p>6. Check for voltage. Disconnect the switched output A connector. Turn the ignition and check voltage at pin 1 to ground. Voltage should be 4.75V to 5.25V.</p> <p>7. Inspect connector and ECU. Disconnect the ECU (794) sensor harness connector. Inspect the sensor harness connector and ECU for damage, dirt, or corrosion.</p> <p>8. Check for voltage. Turn the ignition on and check voltage at pin 18 on the ECU (794) and ground. Voltage should be 4.75V to 5.25V.</p>	<p>If no continuity found on either wire, replace the air pressure sensor harness (WP 0113 00).</p> <p>a. If voltage is not as specified, check continuity of wires between the switched output A connector pins 1 and 3 and ECU (794) sensor connector harness pins 18 and 20.</p> <p>b. If no continuity found at either wire, contact Sustainment Maintenance to replace engine harness.</p> <p>a. Clean and repair connector and required (WP 0113 00).</p> <p>b. Replace damaged ECU (794) (WP 0080 00).</p> <p>If voltage is not as specified, replace ECU (794) (WP 0080 00).</p>



350-1075

END OF WORK PACKAGE

ENGINE PRESSURE SENSOR TROUBLESHOOTING

0023 00

THIS WORK PACKAGE COVERS

Error Code 1122 - Intake Manifold Pressure Sensor Circuit Failure
 Error Code 1123 - Intake Manifold Pressure Sensor Circuit Failure

Error Code 1419 - Intake Manifold Pressure Sensor Circuit Failure
 Error Code 1433 - Intake Manifold Pressure Sensor Circuit Failure

INITIAL SETUP

Tools and Special Tools

Bracket, Lifting, Cylinder Head (Item 10, WP 0289 00)
 Test Lead, Female (Item 121, WP 0289 00)
 Test Lead, Male (Item 124, WP 0289 00)

References

TM 10-3930-675-10
 ECS Engine (A34649.0200) (WP 0048 00-10)

NOTE

- Refer to WP 0004 00 for additional troubleshooting guidance, information, and illustrations that locate critical components.
- Refer also to illustration at end of work package for component location.

Table 1. Error Code 1122 - Intake Manifold Pressure Sensor Circuit Failure Troubleshooting Procedures.


MALFUNCTION	TEST OR INSPECTION	CORRECTIVE ACTION
<p>Error Code 1122 - Intake Manifold Pressure Sensor Circuit Failure.</p> 	<ol style="list-style-type: none"> 1. Ensure ignition switch is in OFF position. Disconnect engine harness from intake manifold pressure sensor (WP 0094 00). 2. Inspect engine harness and sensor connector for dirty, corroded, bent, broken, pushed back, and extended pins. 3. Check engine harness and sensor connector for dirt or moisture in or on connector and for missing or damaged connector seals. 	<p>Clean and repair connector(s) as required (WP 0113 00).</p> <p>Remove dirt and moisture from connector. Replace missing or damaged connector seals (WP 0113 00).</p>

Table 1. Error Code 1122 - Intake Manifold Pressure Sensor Circuit Failure Troubleshooting Procedures - Continued.

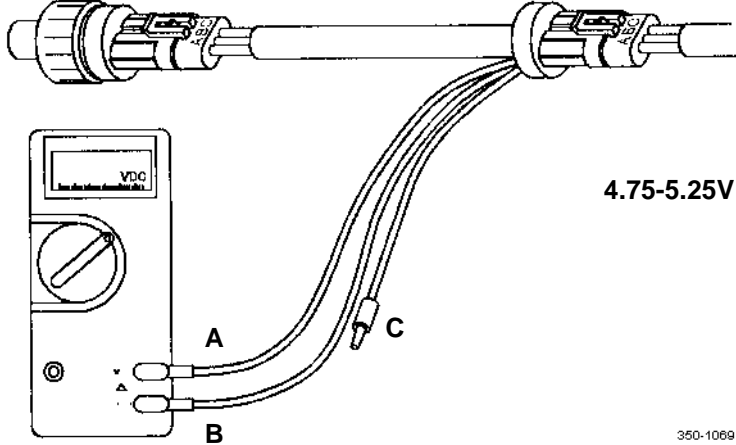
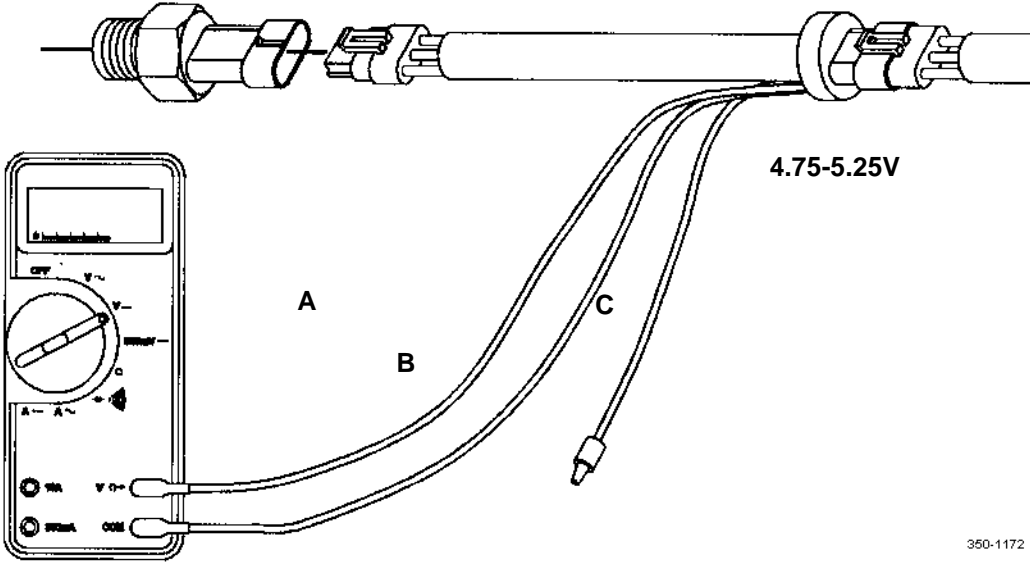
MALFUNCTION	TEST OR INSPECTION	CORRECTIVE ACTION
<p>Error Code 1122 - Intake Manifold Pressure Sensor Circuit Failure - Continued.</p>	<p>4. Disconnect all pressure and temperature sensors from engine harness. Disconnect coolant level sensor jumper wires no. 5 and 6 from 31-pin OEM connector, located on left side of engine to rear of ECU. Install breakout cable. Place ignition switch in ON position.</p> <p>5. Check intake manifold pressure sensor supply voltage. Check voltage between lead A and B of breakout cable. Voltage should be 4.75 to 5.25V.</p>	<p>If voltage is not as specified, perform the following steps.</p>
		
<p>a. Disconnect all pressure and temperature sensors from sensor harness. Disconnect coolant level sensor jumper wires no. 5 and 6 from 31-pin OEM connector. Place ignition switch in ON position. Install breakout cable but do not connect to sensor.</p>		

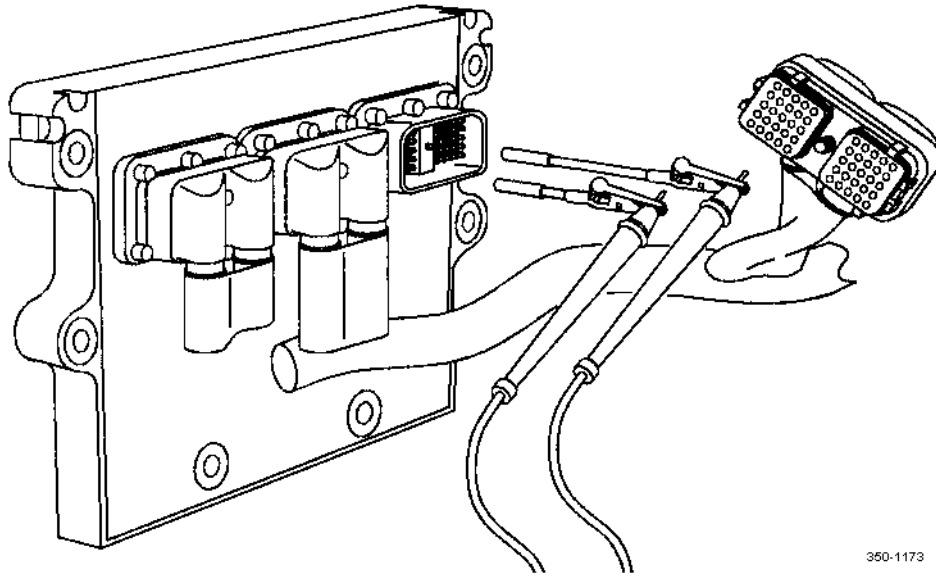
Table 1. Error Code 1122 - Intake Manifold Pressure Sensor
Circuit Failure Troubleshooting Procedures - Continued.

MALFUNCTION	TEST OR INSPECTION	CORRECTIVE ACTION
<p>Error Code 1122 - Intake Manifold Pressure Sensor Circuit Failure - Continued.</p>	<p>b. Check intake manifold pressure sensor supply voltage. Check voltage between lead A and B of breakout cable. Voltage should be 4.75 to 5.25V.</p>  <p>The diagram illustrates a multimeter with its red probe connected to lead A and its black probe connected to lead B of a breakout cable. The voltage reading on the multimeter is labeled as 4.75-5.25V. Lead C is also shown but not connected to the multimeter.</p>	<p>If voltage is as specified, replace intake manifold pressure sensor (WP 0094 00).</p> <p>c. Disconnect sensor harness connector from engine ECU and place ignition switch in ON position.</p>

350-1172

Table 1. Error Code 1122 - Intake Manifold Pressure Sensor Circuit Failure Troubleshooting Procedures - Continued.

MALFUNCTION	TEST OR INSPECTION	CORRECTIVE ACTION
<p>Error Code 1122 - Intake Manifold Pressure Sensor Circuit Failure - Continued.</p>	<p>d. Measure voltage from ECU sensor port connector pin 40 to connector pin 37. Voltage should be 4.75 to 5.25V.</p>	<p>a. If voltage is as specified, replace intake manifold pressure sensor (WP 0094 00). b. If voltage is not as specified, replace engine ECU (WP 0079 00).</p>



360-1173

Table 1. Error Code 1122 - Intake Manifold Pressure Sensor Circuit Failure Troubleshooting Procedures - Continued.

MALFUNCTION	TEST OR INSPECTION	CORRECTIVE ACTION
<p>Error Code 1122 - Intake Manifold Pressure Sensor Circuit Failure - Continued.</p>	<ol style="list-style-type: none"> 6. Disconnect all sensors from sensor harness except intake manifold pressure sensor. Reconnect sensor harness connector to ECU. 7. Disconnect coolant level sensor jumper wires. Install breakout cable. Place ignition switch in ON position. 8. Check intake manifold pressure sensor signal voltage. Check voltage between leads C and B of breakout cable. Voltage should be 0.70 to 1.40V. 	<p>If voltage is not as specified, proceed to following steps.</p>
<p style="text-align: right;">0.70-1.40V</p> <p style="text-align: right; font-size: small;">350-1174</p>		
	<ol style="list-style-type: none"> 9. Place ignition switch in OFF position, disconnect sensor harness from engine ECU, and disconnect all sensors and coolant level jumper wires no. 5 and 6. Disconnect intake manifold pressure sensor. <ol style="list-style-type: none"> a. Measure resistance from sensor harness connector pin 40 to all other pins in connector. Resistance should be greater than 100k Ohms. 	<p>If engine harness requires replacement, notify Sustainment Maintenance.</p>

Table 1. Error Code 1122 - Intake Manifold Pressure Sensor Circuit Failure Troubleshooting Procedures - Continued.

MALFUNCTION	TEST OR INSPECTION	CORRECTIVE ACTION
<p>Error Code 1122 - Intake Manifold Pressure Sensor Circuit Failure - Continued.</p>	<p>b. Measure resistance from sensor harness connector pin 39 to all other pins in connector. Resistance should be greater than 100k Ohms.</p> <p>c. Measure resistance from sensor harness connector pin 37 to all other pins in connector. Resistance should be greater than 100k Ohms.</p>	<p>If engine harness requires replacement, notify Sustainment Maintenance.</p> <p>If engine harness requires replacement, notify Sustainment Maintenance.</p>

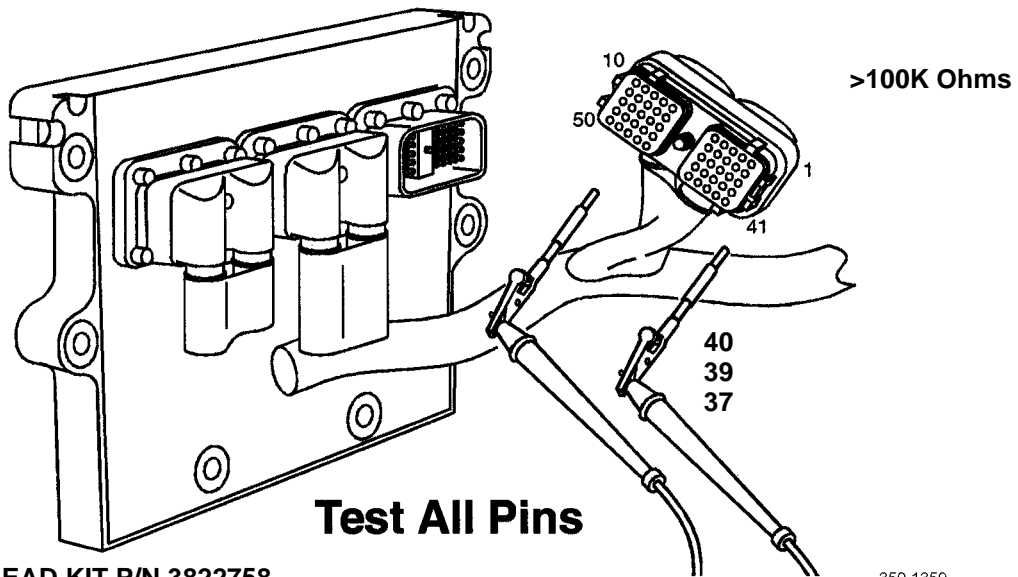
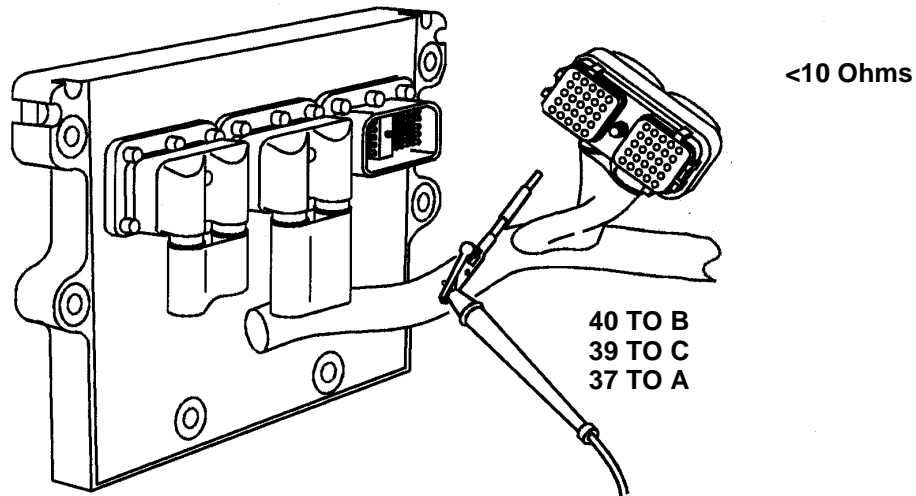


Table 1. Error Code 1122 - Intake Manifold Pressure Sensor Circuit Failure Troubleshooting Procedures - Continued.

MALFUNCTION	TEST OR INSPECTION	CORRECTIVE ACTION
<p>Error Code 1122 - Intake Manifold Pressure Sensor Circuit Failure - Continued.</p>	<p>10. Check for resistance in sensor harness.</p> <p>a. Measure resistance from sensor harness connector pin 37 to sensor connector pin A. Resistance should be less than 10 Ohms.</p> <p>b. Measure resistance from sensor harness connector pin 40 to sensor connector pin B. Resistance should be less than 10 Ohms.</p> <p>c. Measure resistance from sensor harness connector pin 39 to sensor connector pin C. Resistance should be less than 10 Ohms.</p>	<p>If engine harness requires replacement, notify Sustainment Maintenance.</p> <p>If engine harness requires replacement, notify Sustainment Maintenance.</p> <p>If engine harness requires replacement, notify Sustainment Maintenance.</p>



USE TEST LEAD KIT P/N 3822758

350-1360

Table 1. Error Code 1122 - Intake Manifold Pressure Sensor Circuit Failure Troubleshooting Procedures - Continued.

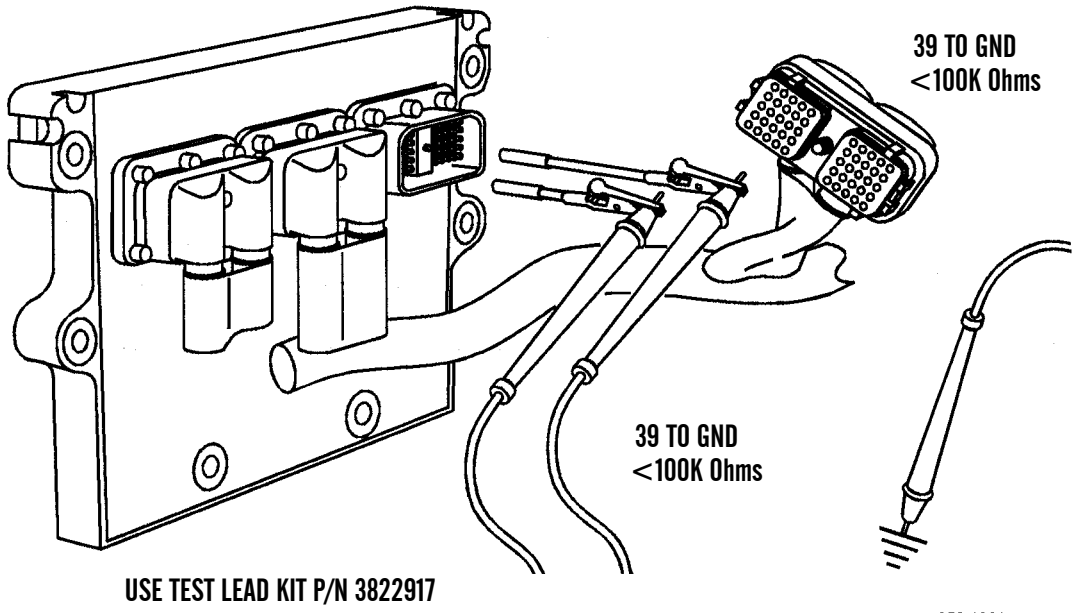
MALFUNCTION	TEST OR INSPECTION	CORRECTIVE ACTION
<p>Error Code 1122 - Intake Manifold Pressure Sensor Circuit Failure - Continued.</p>  <p>USE TEST LEAD KIT P/N 3822917</p> <p>350-1361</p>	<p>11. Place ignition switch in OFF position and disconnect sensor harness connector from engine ECU.</p> <p>a. Measure resistance from pin 39 to pin 40 at sensor port of ECU.</p> <p>b. Measure resistance from pin 39 of ECU sensor port to engine block ground.</p>	<p>a. If resistance is less than 100k Ohms, replace intake manifold pressure sensor (WP 0094 00).</p> <p>b. If resistance is greater than 100k Ohms, replace engine ECU (WP 0079 00).</p> <p>If resistance is greater than 100k Ohms, replace engine ECU (WP 0079 00).</p>

Table 2. Error Code 1123 - Intake Manifold Pressure Sensor Circuit Failure Troubleshooting Procedures.


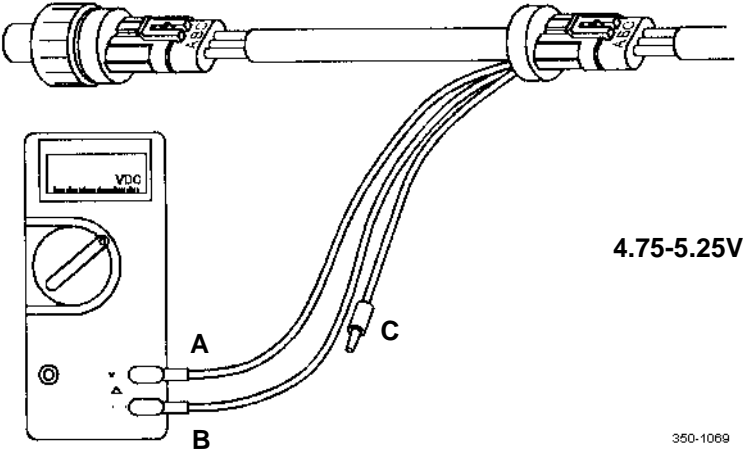
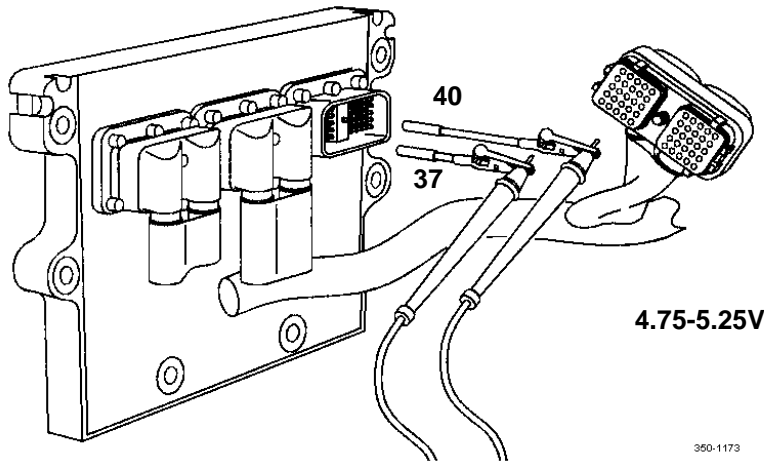
MALFUNCTION	TEST OR INSPECTION	CORRECTIVE ACTION
<p>Error Code 1123 - Intake Manifold Pressure Sensor Circuit Failure.</p> 	<ol style="list-style-type: none"> 1. Ensure ignition switch is in OFF position. Disconnect engine harness from intake manifold pressure sensor (WP 0094 00). 2. Inspect engine harness and sensor connector for dirty, corroded, bent, broken, pushed back, and extended pins. 3. Check engine harness and sensor connector for dirt or moisture in or on connector and for missing or damaged connector seals. 4. Install breakout cable. Place ignition switch in ON position. Check intake manifold pressure sensor supply voltage. Check voltage between lead A and B of breakout cable. Voltage should be 4.75 to 5.25V. 	<p>Clean and repair connector(s) as required (WP 0113 00).</p> <p>Remove dirt and moisture from connector. Replace missing or damaged connector seals (WP 0113 00).</p> <p>If voltage is not as specified, proceed to the following steps.</p>
 <p style="text-align: right;">4.75-5.25V</p> <p style="text-align: right;"><small>350-1069</small></p>		

Table 2. Error Code 1123 - Intake Manifold Pressure Sensor Circuit Failure Troubleshooting Procedures - Continued.

MALFUNCTION	TEST OR INSPECTION	CORRECTIVE ACTION
<p>Error Code 1123 - Intake Manifold Pressure Sensor Circuit Failure - Continued.</p>	<p>5. Disconnect sensor harness connector from engine ECU and place ignition switch to ON position.</p> <p>6. Measure voltage from ECU sensor port connector pin 40 to connector pin 37. Voltage should be 4.75 to 5.25V.</p>	<p>If voltage is not as specified, proceed with the following steps.</p> <p>a. If engine harness requires replacement, notify Sustainment Maintenance.</p> <p>b. If voltage is not as specified, replace engine ECU (WP 0079 00).</p>

USE TEST LEAD KIT P/N 3822758



350-1173

Table 2. Error Code 1123 - Intake Manifold Pressure Sensor Circuit Failure Troubleshooting Procedures - Continued.

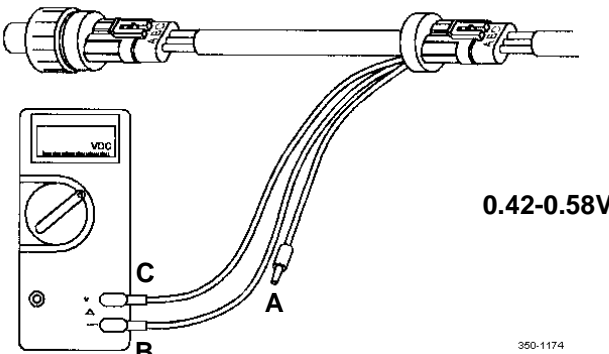
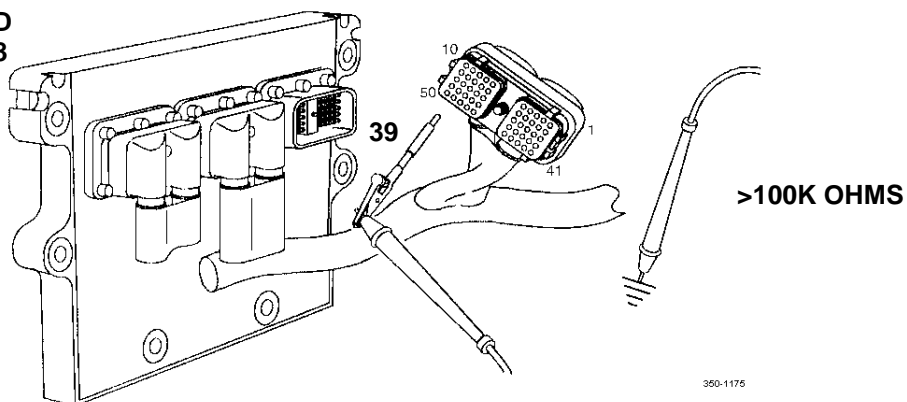
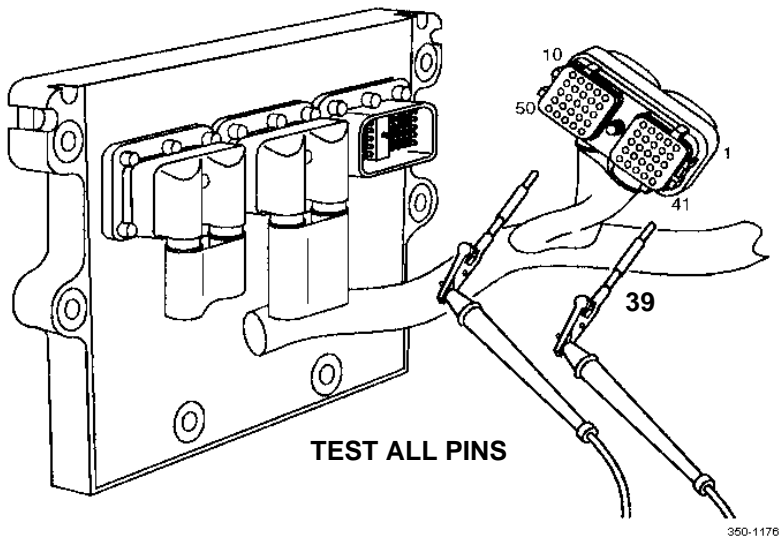
MALFUNCTION	TEST OR INSPECTION	CORRECTIVE ACTION
<p>Error Code 1123 - Intake Manifold Pressure Sensor Circuit Failure - Continued.</p>	<p>7. Install breakout cable. Place ignition switch in ON position and check intake manifold pressure sensor signal voltage. Check voltage between lead B and C of breakout cable. Voltage should be 0.42 to 0.58V.</p>	<p>If voltage is not as specified, proceed with the following steps.</p>
<div style="text-align: center;">  <p>0.42-0.58V</p> <p>360-1174</p> </div>		
<p>8. Place ignition switch in OFF position. Disconnect intake manifold pressure sensor from engine harness and disconnect sensor harness from engine ECU.</p> <p>a. Measure resistance from sensor harness connector pin 39 to chassis ground. Resistance should be more than 100k Ohms.</p>		
<div style="display: flex; justify-content: space-between;"> <div data-bbox="227 1480 446 1543"> <p>USE TEST LEAD KIT P/N 3822758</p> </div> <div data-bbox="430 1480 1331 1879">  <p>>100K OHMS</p> <p>360-1175</p> </div> </div>		
<p style="text-align: center;">0023 00-11</p>		

Table 2. Error Code 1123 - Intake Manifold Pressure Sensor Circuit Failure Troubleshooting Procedures - Continued.

MALFUNCTION	TEST OR INSPECTION	CORRECTIVE ACTION
<p>Error Code 1123 - Intake Manifold Pressure Sensor Circuit Failure - Continued.</p>	<p>b. Measure resistance from sensor harness connector pin 39 to all other pins in connector. Resistance should be more than 100k Ohms.</p>	<p>a. If resistance is as specified, replace intake manifold pressure sensor (WP 0094 00). b. If resistance is not as specified, notify Sustainment Maintenance.</p>



9. Turn ignition switch to OFF position, disconnect intake manifold pressure sensor from engine harness, and disconnect sensor harness from engine ECU.

Table 2. Error Code 1123 - Intake Manifold Pressure Sensor Circuit Failure Troubleshooting Procedures - Continued.

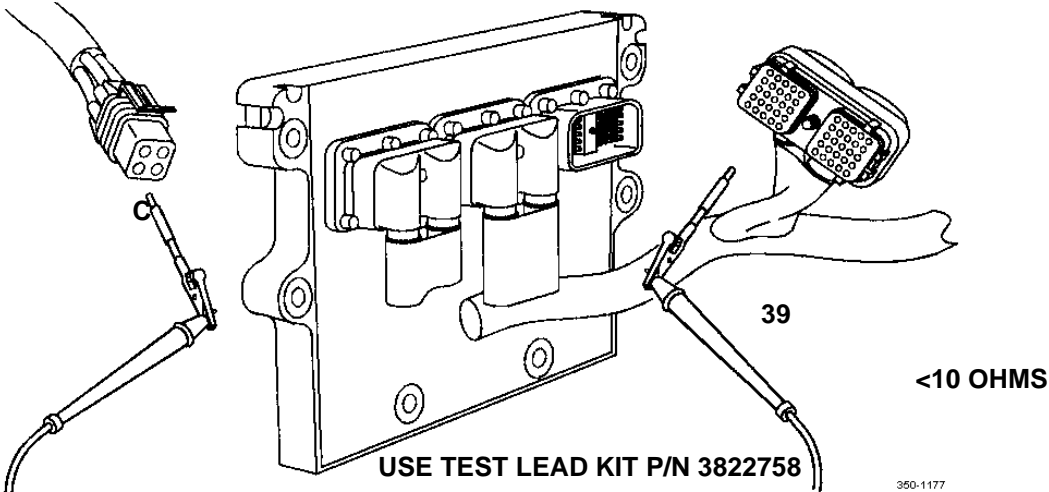
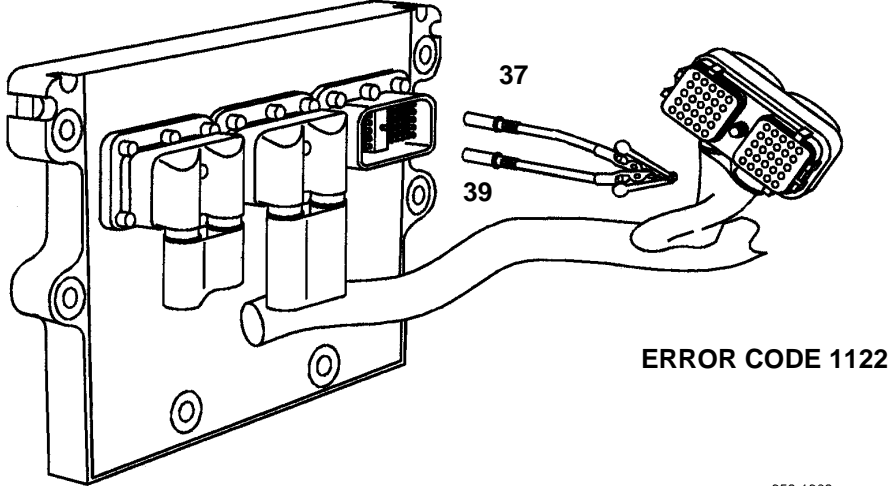
MALFUNCTION	TEST OR INSPECTION	CORRECTIVE ACTION
<p>Error Code 1123 - Intake Manifold Pressure Sensor Circuit Failure - Continued.</p>	<p>10. Measure resistance from sensor harness connector pin 39 to intake manifold pressure sensor connector pin C. Resistance should be less than 10 Ohms.</p>	<p>If engine harness requires replacement, notify Sustainment Maintenance.</p>
		
<p>11. Disconnect sensor harness connector from engine ECU. Place ignition switch in ON position. Install jumper wire between ECU sensor port pin 37 and 39. Error code 1122 should be displayed.</p>		
		

Table 3. Error Code 1419 - Intake Manifold Pressure Sensor Circuit Failure Troubleshooting Procedures.


MALFUNCTION	TEST OR INSPECTION	CORRECTIVE ACTION
<p>Error Code 1419 - Intake Manifold Pressure Sensor Circuit Failure.</p> 		<p>Notify Sustainment Maintenance.</p>

Table 4. Error Code 1433 - Intake Manifold Pressure Sensor Circuit Failure Troubleshooting Procedures.


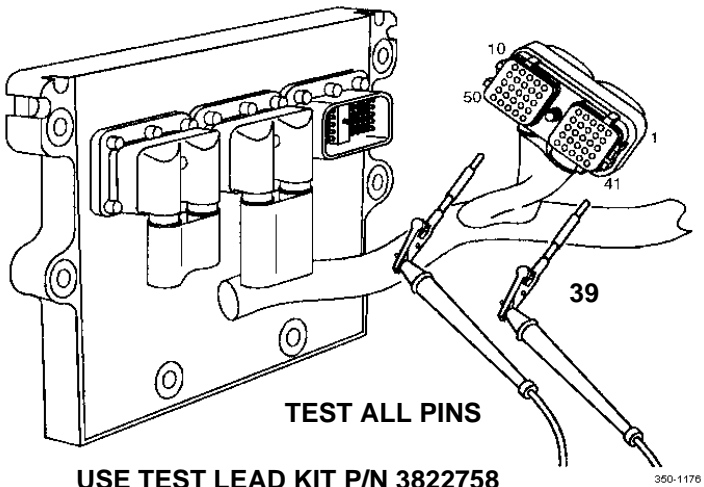
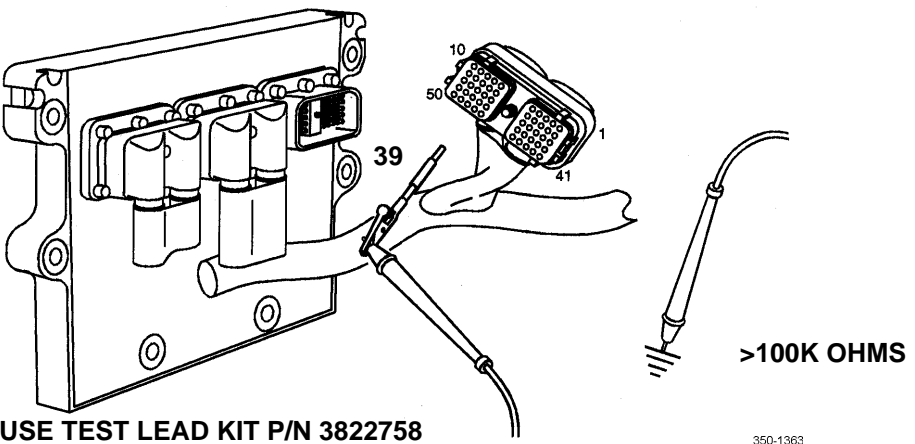
MALFUNCTION	TEST OR INSPECTION	CORRECTIVE ACTION
<p>Error Code 1433 - Intake Manifold Pressure Sensor Circuit Failure.</p> 	<ol style="list-style-type: none"> 1. Ensure ignition switch is in OFF position. Disconnect engine harness from intake manifold pressure sensor (WP 0094 00). 2. Inspect engine harness and sensor connector for dirty, corroded, bent, broken, pushed back, and extended pins. 3. Check engine harness and sensor connector for dirt or moisture in or on connector and for missing or damaged connector seals. 4. Place ignition switch in OFF position and disconnect sensor harness connector from engine ECU. 5. Inspect engine harness and sensor connector for dirty, corroded, bent, broken, pushed back, and extended pins. 6. Check engine harness and engine ECU connector for dirt or moisture in or on connector and for missing or damaged connector seals. 	<p>Clean and repair connector(s) as required (WP 0113 00).</p> <p>Remove dirt and moisture from connector. Replace missing or damaged connector seals (WP 0113 00).</p> <p>Clean and repair connector(s) as required (WP 0113 00).</p> <p>Remove dirt and moisture from connector. Replace missing or damaged connector seals (WP 0113 00).</p>

Table 4. Error Code 1433 - Intake Manifold Pressure Sensor Circuit Failure Troubleshooting Procedures - Continued.

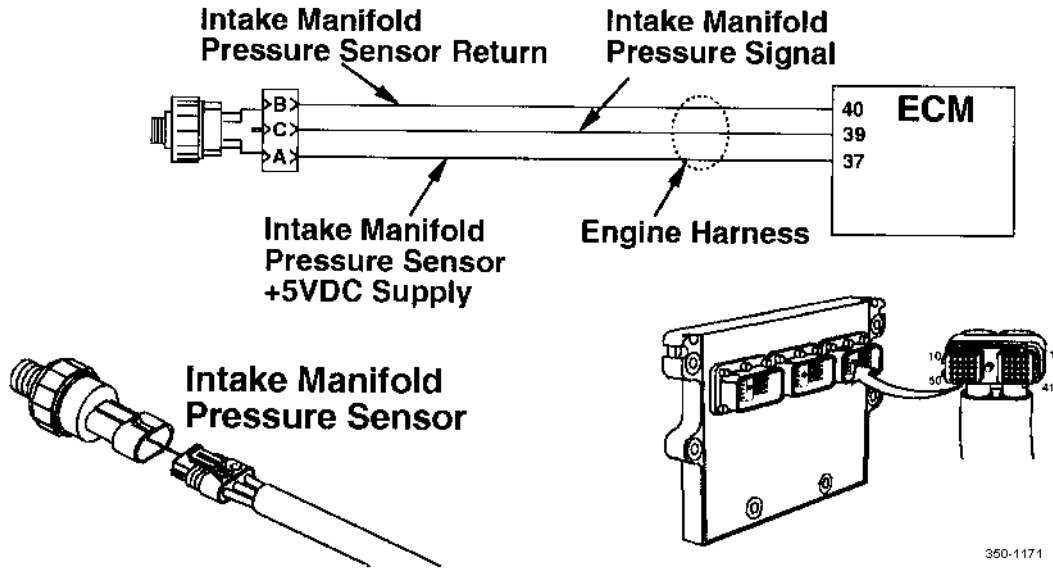
MALFUNCTION	TEST OR INSPECTION	CORRECTIVE ACTION
<p>Error Code 1433 - Intake Manifold Pressure Sensor Circuit Failure - Continued.</p>	<p>7. Place ignition switch in OFF position. Disconnect sensor harness from intake manifold pressure sensor, and disconnect sensor harness from engine ECU.</p> <p>8. Measure resistance from sensor harness connector pin 40 to intake manifold pressure sensor connector pin 2. Resistance should be less than 10 Ohms.</p>	<p>If engine harness requires replacement, notify Sustainment Maintenance.</p>
<p>USE TEST LEAD KIT P/N 3822758</p>		
	<p>9. Place ignition switch in OFF position. Disconnect sensor harness from intake manifold pressure sensor and from engine ECU. Measure resistance from sensor harness connector pin 39 to all other pins in connector. Resistance should be more than 100k Ohms.</p>	<p>a. If resistance is as specified, replace intake manifold pressure sensor (WP 0094 00).</p> <p>b. If resistance is not as specified, notify Sustainment Maintenance.</p>

Table 4. Error Code 1433 - Intake Manifold Pressure Sensor Circuit Failure Troubleshooting Procedures - Continued.

MALFUNCTION	TEST OR INSPECTION	CORRECTIVE ACTION
<p>Error Code 1433 - Intake Manifold Pressure Sensor Circuit Failure - Continued.</p>  <p>TEST ALL PINS</p> <p>USE TEST LEAD KIT P/N 3822758</p>	<p>10. Place ignition switch in OFF position. Disconnect sensor harness from intake manifold pressure sensor and from engine ECU.</p> <p>11. Measure resistance from pin 39 in sensor harness to engine block ground. Resistance should be greater than 100k Ohms.</p>	<p>a. If resistance is as specified, replace intake manifold pressure sensor (WP 0094 00).</p> <p>b. If resistance is not as specified, notify Sustainment Maintenance.</p>  <p>USE TEST LEAD KIT P/N 3822758</p>

NOTE

Intake manifold pressure sensor is located on top right side of engine under air intake tube.



END OF WORK PACKAGE

THIS WORK PACKAGE COVERS

Error Code 1254 - Fuel Shutoff Solenoid Circuit Failure
 Error Code 1255 - Fuel Shutoff Solenoid External Voltage Detected on Circuit

Error Code 1581 - Fuel Inlet Restriction Sensor Circuit Failure

INITIAL SETUP

Tools and Special Tools

- Cable, Breakout (Item 12, WP 0289 00)
- Cable, Breakout (Item 13, WP 0289 00)
- Test Lead, Female (Item 121, WP 0289 00)

Tools and Special Tools - Continued

- Test Lead, Male (Item 124, WP 0289 00)

References

- TM 10-3930-675-10

NOTE

- Refer to WP 0004 00 for additional troubleshooting guidance, information, and illustrations that locate critical components.
- Refer also to illustrations at end of work package for component location.

Table 1. Error Code 1254 - Fuel Shutoff Solenoid Circuit Failure Troubleshooting Procedures.

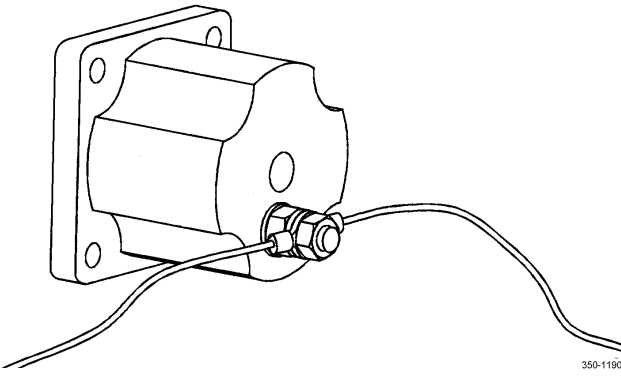
MALFUNCTION	TEST OR INSPECTION	CORRECTIVE ACTION
<p>Error Code 1254 - Fuel Shutoff Solenoid Circuit Failure.</p>	<p>1. Check fuel shutoff solenoid post for corrosion.</p>	<p>Clean solenoid post and wire terminal as required.</p>
		

Table 1. Error Code 1254 - Fuel Shutoff Solenoid Circuit Failure Troubleshooting Procedures - Continued.

MALFUNCTION	TEST OR INSPECTION	CORRECTIVE ACTION
<p>Error Code 1254 - Fuel Shutoff Solenoid Circuit Failure - Continued.</p>	<p>2. Disconnect actuator harness from fuel shutoff solenoid. Place ignition switch in ON position.</p> <p>Measure voltage from fuel shutoff control wire connectors to engine block ground. Voltage should be greater than 6V.</p>	<p>If engine harness requires replacement, contact sustainment maintenance.</p>
	<p>3. Place ignition switch in OFF position and disconnect actuator harness from engine ECU.</p> <p>a. Inspect engine ECU and actuator harness connector for dirty, corroded, bent, broken, pushed back, and extended pins.</p> <p>b. Check engine ECU and actuator harness connector for dirt or moisture in or on connector and for missing or damaged connector seals.</p>	<p>Clean and repair connector(s) as required (WP 0113 00).</p> <p>Remove dirt and moisture from connector. Replace missing or damaged connector seals (WP 0113 00).</p>

Table 1. Error Code 1254 - Fuel Shutoff Solenoid Circuit Failure Troubleshooting Procedures - Continued.

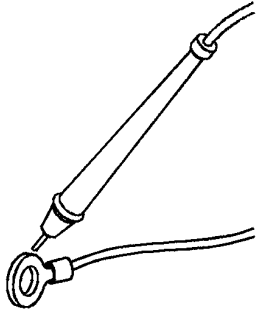
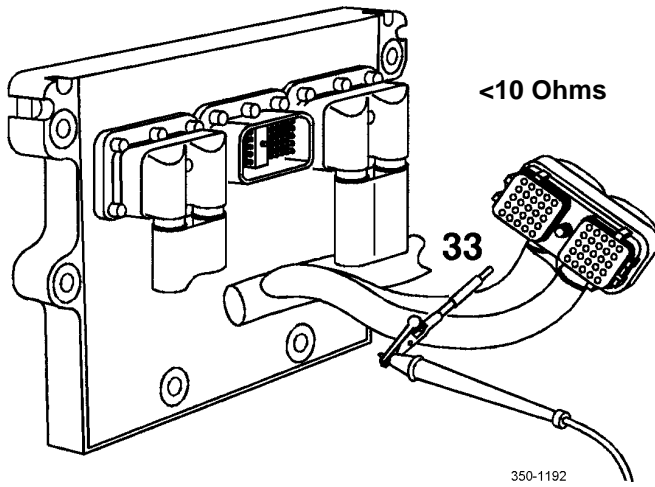
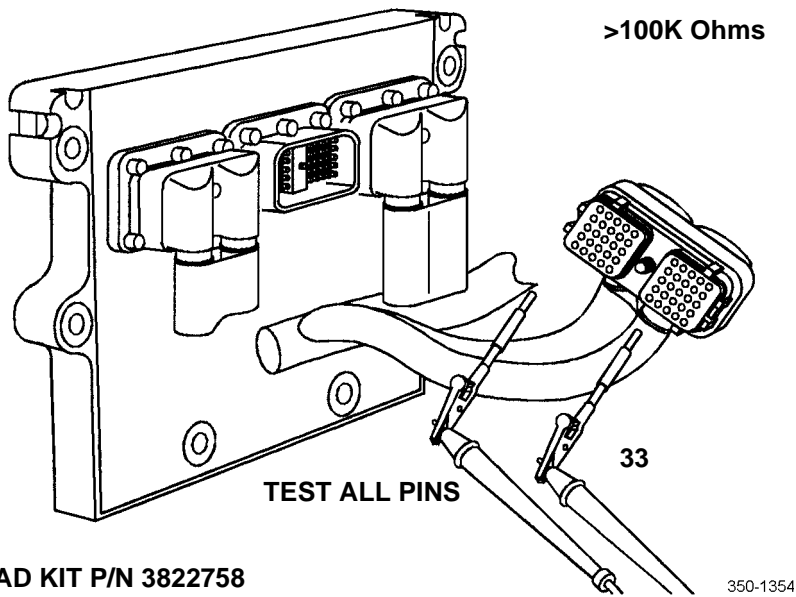
MALFUNCTION	TEST OR INSPECTION	CORRECTIVE ACTION
<p>Error Code 1254 - Fuel Shutoff Solenoid Circuit Failure - Continued.</p>  <p>Fuel Shut Off Valve Actuator Wire</p>	<p>4. Place ignition switch in OFF position and disconnect actuator wire from fuel shutoff solenoid and disconnect actuator harness connector from engine ECU.</p> <p>Measure resistance from actuator harness pin 33 to fuel shutoff control wire. Resistance should be less than 10 Ohms.</p>  <p><10 Ohms</p> <p>33</p> <p>350-1192</p>	<p>If engine harness requires replacement, notify Sustainment Maintenance.</p>

Table 1. Error Code 1254 - Fuel Shutoff Solenoid Circuit Failure Troubleshooting Procedures - Continued.

MALFUNCTION	TEST OR INSPECTION	CORRECTIVE ACTION
<p>Error Code 1254 - Fuel Shutoff Solenoid Circuit Failure - Continued.</p>	<p>5. Place ignition switch in OFF position. Disconnect actuator harness from engine ECU. Disconnect actuator wire from fuel shutoff valve.</p> <p>Measure resistance from pin 33 of actuator harness connector to all other pins in connector. Resistance should be more than 100k Ohms.</p>	<p>If engine harness requires replacement, notify Sustainment Maintenance.</p>



USE TEST LEAD KIT P/N 3822758

Table 1. Error Code 1254 - Fuel Shutoff Solenoid Circuit Failure Troubleshooting Procedures - Continued.

MALFUNCTION	TEST OR INSPECTION	CORRECTIVE ACTION
<p>Error Code 1254 - Fuel Shutoff Solenoid Circuit Failure - Continued.</p>	<p>6. Disconnect actuator harness from engine ECU. Place ignition switch in ON position.</p> <p>Measure voltage from engine ECU pin 33 to engine block ground. Voltage should be greater than 6V.</p>	<p>a. If engine harness requires replacement, notify Sustainment Maintenance.</p> <p>b. If voltage is not as specified, replace engine ECU (WP007900).</p>

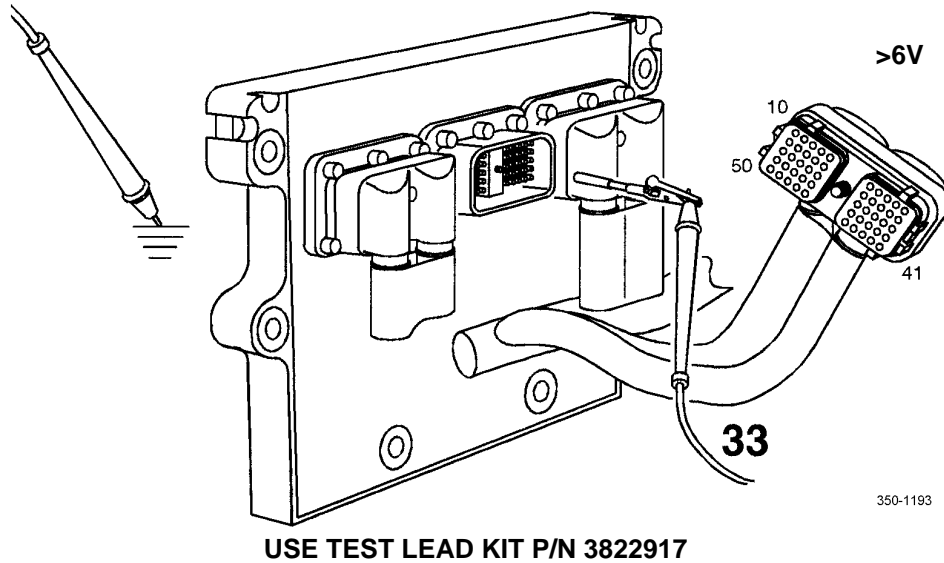
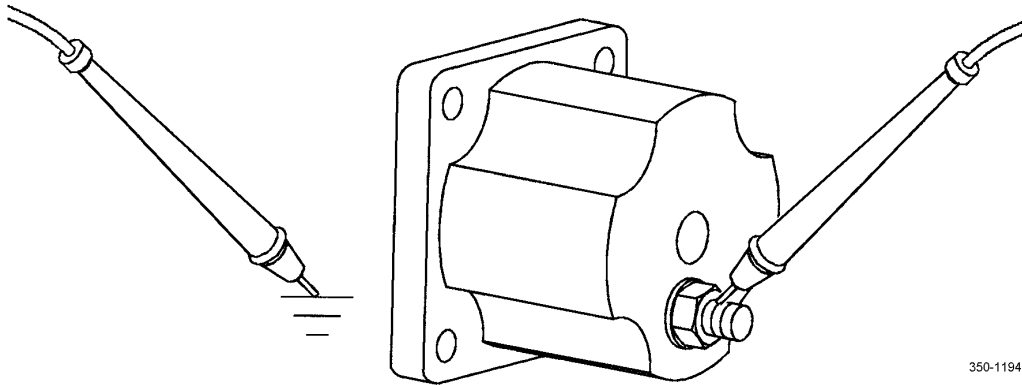


Table 1. Error Code 1254 - Fuel Shutoff Solenoid Circuit Failure Troubleshooting Procedures - Continued.


MALFUNCTION	TEST OR INSPECTION	CORRECTIVE ACTION
<p>Error Code 1254 - Fuel Shutoff Solenoid Circuit Failure - Continued.</p>	<p>7. Place ignition switch in OFF position and disconnect actuator harness from fuel shutoff solenoid.</p> <p>8. Measure resistance from fuel shutoff solenoid to engine block ground. Resistance should be 7 to 8 Ohms for 12V solenoids.</p>	<p>If resistance is not as specified, replace fuel shutoff solenoid (WP 0056 00).</p>

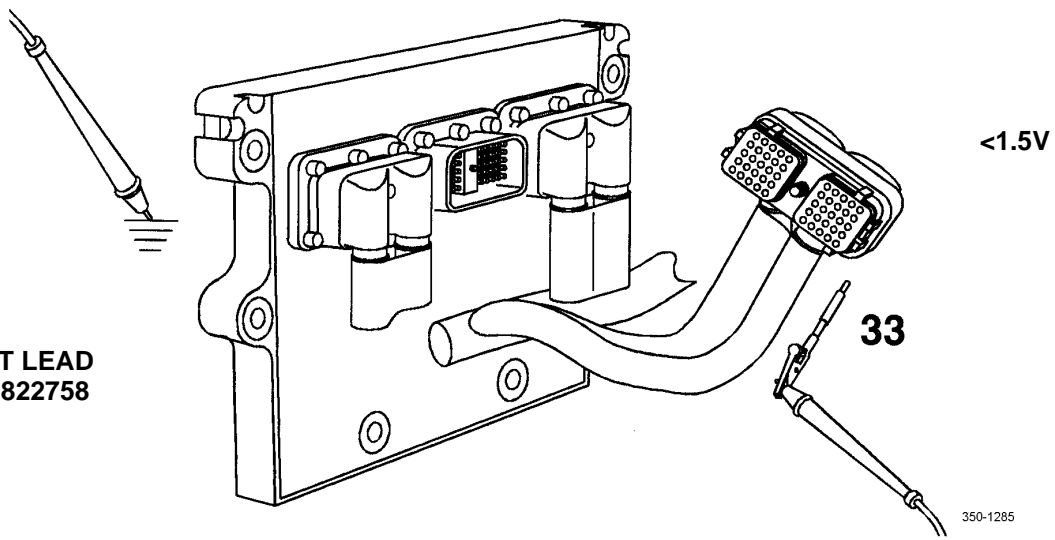
12V = 7-8 Ohms



350-1194

Table 2. Error Code 1255 - Fuel Shutoff Solenoid External Voltage Detected on Circuit Troubleshooting Procedures.

MALFUNCTION	TEST OR INSPECTION	CORRECTIVE ACTION
<p>Error Code 1255 - Fuel Shutoff Solenoid External Voltage Detected on Circuit.</p> 	<ol style="list-style-type: none"> 1. Place ignition switch in OFF position and disconnect actuator harness connector from engine ECU. <ol style="list-style-type: none"> a. Inspect harness connector and engine ECU connector for dirty, corroded, bent, broken, pushed back, and extended pins. b. Check harness and engine ECU for dirt or moisture in or on connector and for missing or damaged connector seals. 2. Disconnect actuator harness connector from engine ECU. Place ignition switch in ON position. 3. Measure voltage from actuator harness connector pin 33 to engine block ground. Voltage should be less than 1.5V. 	<p>Clean and repair connector(s) as required (WP 0113 00).</p> <p>Remove dirt and moisture from connector. Replace missing or damaged connector seals (WP 0113 00).</p> <p>If voltage is not as specified, proceed with the following steps.</p>



USE TEST LEAD KIT P/N 3822758

33

<1.5V

350-1285

Table 2. Error Code 1255 - Fuel Shutoff Solenoid External Voltage Detected on Circuit Troubleshooting Procedures - Continued.

MALFUNCTION	TEST OR INSPECTION	CORRECTIVE ACTION
<p>Error Code 1255 - Fuel Shutoff Solenoid External Voltage Detected on Circuit - Continued.</p>	<ol style="list-style-type: none"> 4. Place ignition switch in OFF position, disconnect actuator harness connector from engine ECU, and disconnect actuator wire from fuel shutoff solenoid. 5. Measure resistance from actuator harness connector pin 33 to all other pins in connector. Resistance should be greater than 100k Ohms. 	<p>Notify Sustainment Maintenance to replace engine harness.</p>

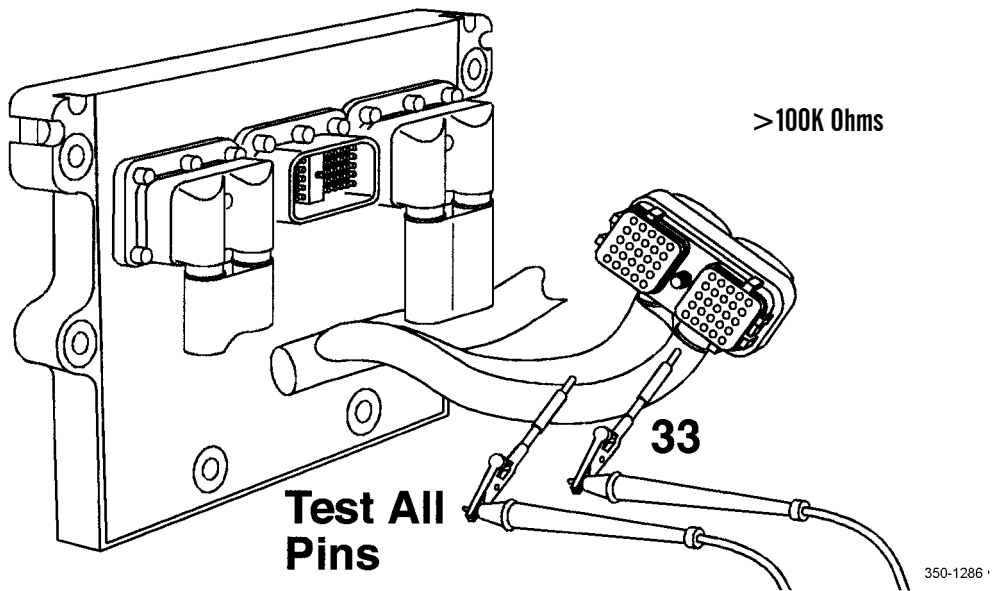

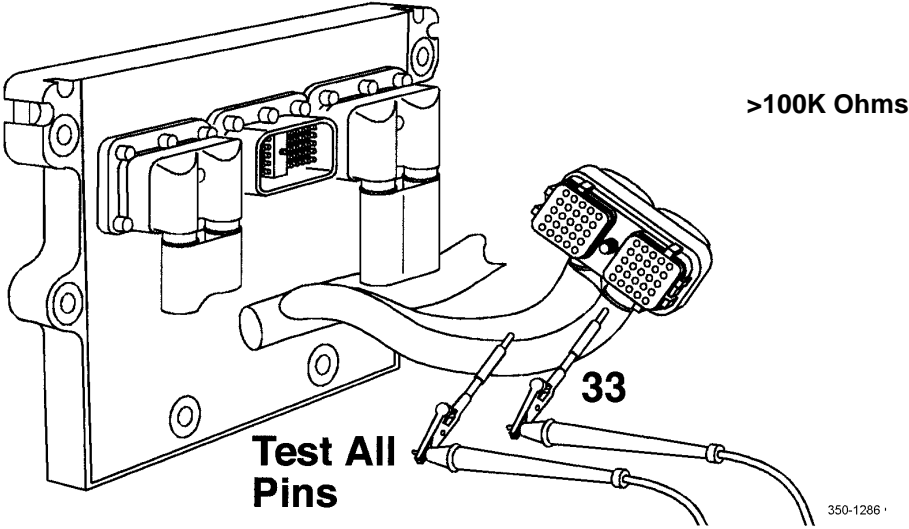
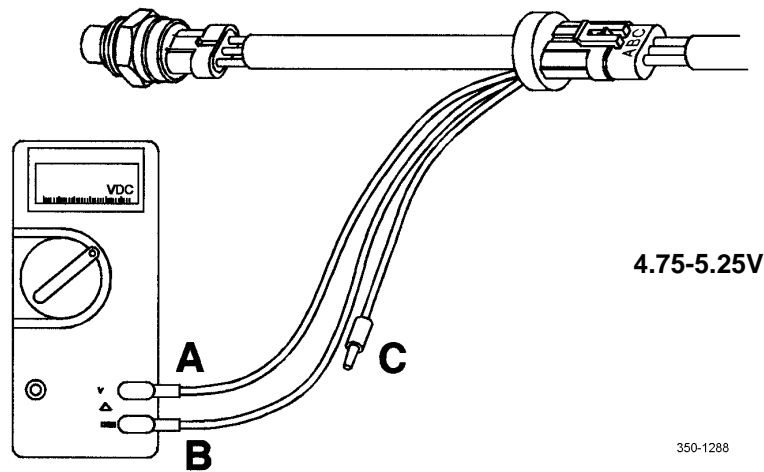


Table 3. Error Code 1581 - Fuel Inlet Restriction Sensor Circuit Failure Troubleshooting Procedures.

MALFUNCTION	TEST OR INSPECTION	CORRECTIVE ACTION
<p>Error Code 1581 - Fuel Inlet Restriction Sensor Circuit Failure.</p> 	<ol style="list-style-type: none"> 1. Place ignition switch in OFF position and disconnect fuel inlet restriction sensor from engine harness (WP 0094 00). <ol style="list-style-type: none"> a. Inspect fuel inlet restriction sensor connector and engine harness connector for dirty, corroded, bent, broken, pushed back, and extended pins. b. Check fuel inlet restriction sensor and engine harness for dirt or moisture in or on connector and for missing or damaged connector seals. 	<p>Clean and repair connector(s) as required (WP 0113 00).</p> <p>Remove dirt and moisture from connector. Replace missing or damaged connector seals (WP 0113 00).</p>
 <p style="text-align: right;">>100K Ohms</p> <p style="text-align: center;">33</p> <p style="text-align: center;">Test All Pins</p> <p style="text-align: right; font-size: small;">350-1286</p>		

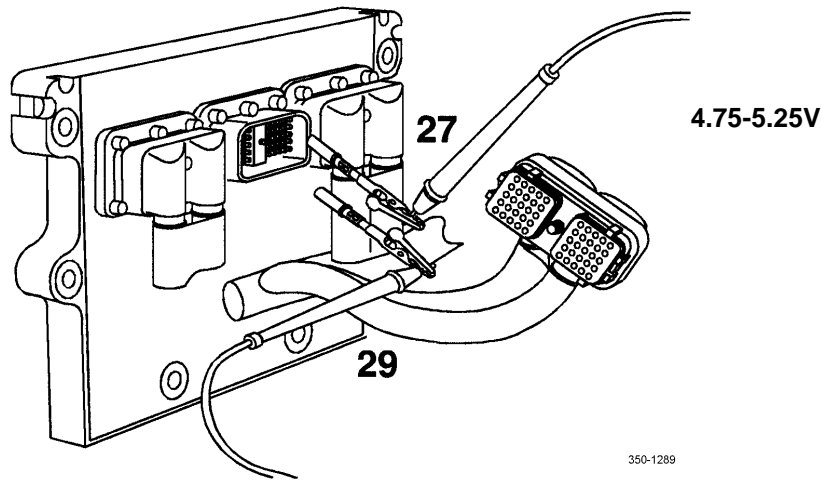
**Table 3. Error Code 1581 - Fuel Inlet Restriction
Sensor Circuit Failure Troubleshooting Procedures - Continued.**

MALFUNCTION	TEST OR INSPECTION	CORRECTIVE ACTION
<p>Error Code 1581 - Fuel Inlet Restriction Sensor Circuit Failure - Continued.</p>	<p>2. Install breakout cable P/N 3824775 between sensor and harness connector. Place ignition switch in ON position.</p> <p>3. Measure supply voltage at pin 1 or A (red) and pin 2 or B (black). Voltage should be 4.75 to 5.25V.</p>	<p>a. If voltage is as specified, repair or replace connectors (WP 0113 00).</p> <p>b. If engine harness requires replacement, notify Sustainment Maintenance.</p> <p>c. If voltage is not as specified, replace engine ECU (WP0079 00).</p>



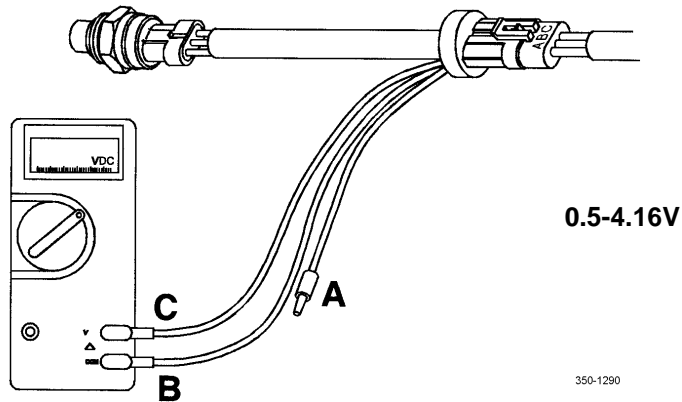
**Table 3. Error Code 1581 - Fuel Inlet Restriction
Sensor Circuit Failure Troubleshooting Procedures - Continued.**

MALFUNCTION	TEST OR INSPECTION	CORRECTIVE ACTION
<p>Error Code 1581 - Fuel Inlet Restriction Sensor Circuit Failure - Continued.</p>	<p>4. Disconnect actuator harness connector from engine ECU. Turn ignition switch to ON position and measure voltage from engine ECU pin 29 to pin 27 at actuator port of ECU. Voltage should be 4.75 to 5.25V.</p>	<p>a. If voltage is as specified, repair or replace connectors (WP 0113 00). b. If engine harness requires replacement, notify Sustainment Maintenance. c. If voltage is not as specified, replace engine ECU (WP0079 00).</p>



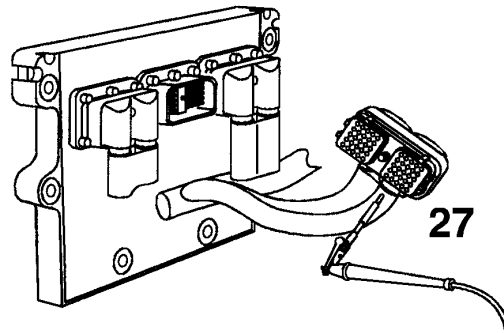
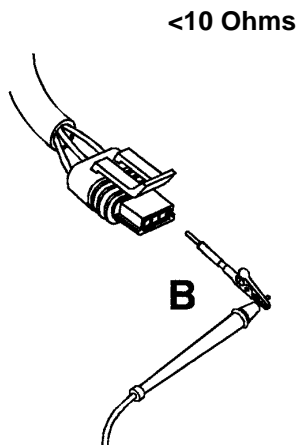
**Table 3. Error Code 1581 - Fuel Inlet Restriction
Sensor Circuit Failure Troubleshooting Procedures - Continued.**

MALFUNCTION	TEST OR INSPECTION	CORRECTIVE ACTION
<p>Error Code 1581 - Fuel Inlet Restriction Sensor Circuit Failure - Continued.</p>	<p>5. Install breakout cable P/N 3824775 between sensor and harness connector. Place ignition switch in ON position.</p> <p>6. Measure signal voltage at pin 3 or C and pin 2 or B. Voltage should be 0.5 to 4.16V.</p>	<p>a. If voltage is as specified, repair or replace connectors (WP 0113 00).</p> <p>b. If engine harness requires replacement, notify Sustainment Maintenance.</p> <p>c. If voltage is not as specified, replace engine ECU (WP0079 00).</p>



**Table 3. Error Code 1581 - Fuel Inlet Restriction
Sensor Circuit Failure Troubleshooting Procedures - Continued.**

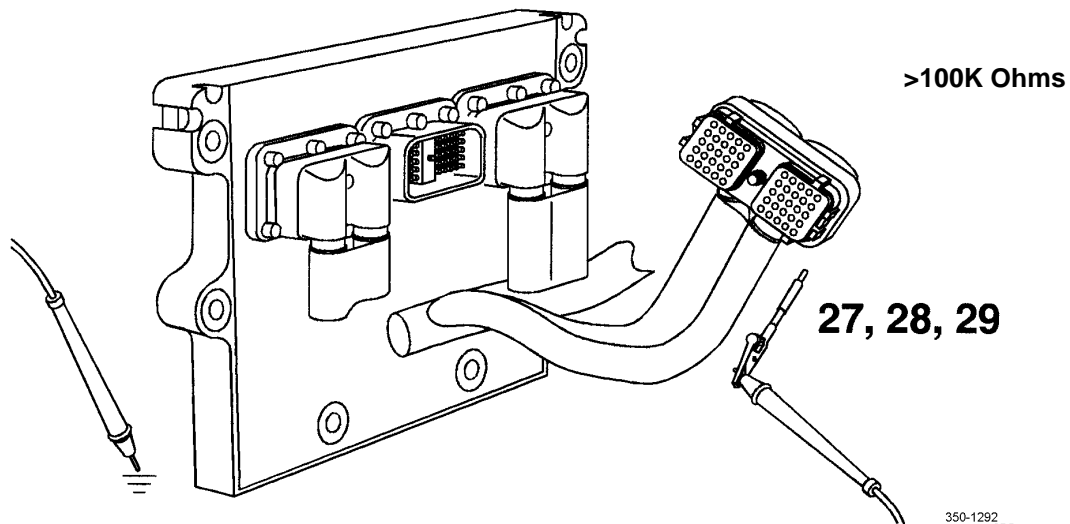
MALFUNCTION	TEST OR INSPECTION	CORRECTIVE ACTION
<p>Error Code 1581 - Fuel Inlet Restriction Sensor Circuit Failure - Continued.</p>	<p>7. Place ignition switch in OFF position and disconnect actuator harness connector from engine ECU.</p> <p>a. Inspect harness connector and engine ECU connector for dirty, corroded, bent, broken, pushed back, and extended pins.</p> <p>b. Check harness and engine ECU for dirt or moisture in or on connector and for missing or damaged connector seals.</p> <p>8. Place ignition switch in OFF position, disconnect actuator harness connector from engine ECU, and disconnect fuel inlet restriction sensor from engine harness.</p> <p>9. Measure resistance from actuator harness connector pin 27 to pin B (or 2) of 3 pin connector at sensor. Resistance should be less than 10 Ohms.</p>	<p>Clean and repair connector(s) as required (WP 0113 00).</p> <p>Remove dirt and moisture from connector. Replace missing or damaged connector seals (WP 0113 00).</p> <p>a. If resistance is as specified, repair or replace connectors (WP 0113 00).</p> <p>b. If engine harness requires replacement, notify Sustainment Maintenance.</p>



350-1291

**Table 3. Error Code 1581 - Fuel Inlet Restriction
Sensor Circuit Failure Troubleshooting Procedures - Continued.**

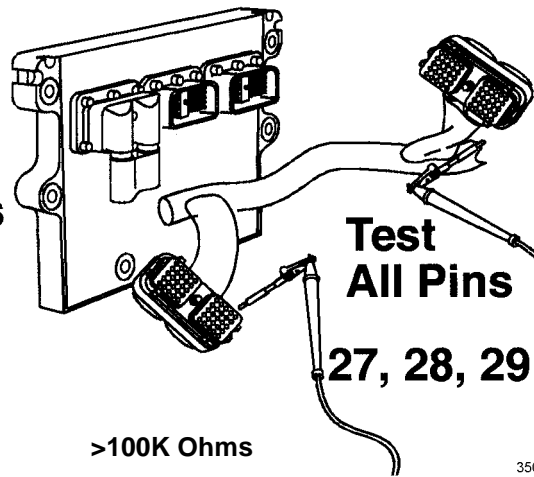
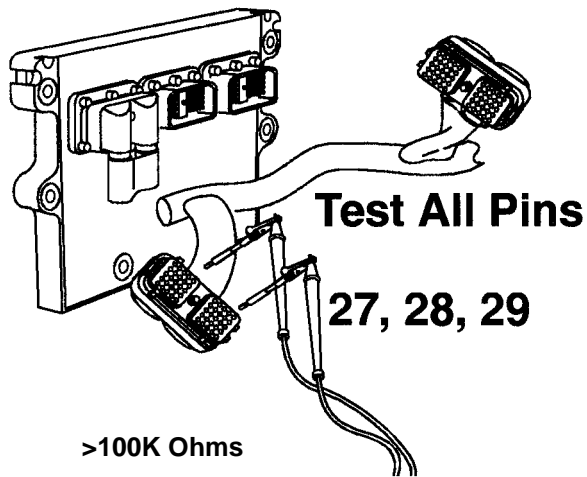
MALFUNCTION	TEST OR INSPECTION	CORRECTIVE ACTION
<p>Error Code 1581 - Fuel Inlet Restriction Sensor Circuit Failure - Continued.</p>	<p>10. Place ignition switch in OFF position, disconnect actuator harness connector from engine ECU, and disconnect fuel inlet restriction sensor from engine harness.</p> <p>a. Measure resistance from actuator harness connector pin 27 to engine block ground. Resistance should be greater than 100k Ohms.</p> <p>b. Measure resistance from actuator harness connector pin 28 to engine block ground. Resistance should be greater than 100k Ohms.</p> <p>c. Measure resistance from actuator harness connector pin 29 to engine block ground. Resistance should be greater than 100k Ohms.</p>	<p>a. If resistance is as specified, repair or replace connectors (WP 0113 00).</p> <p>b. If engine harness requires replacement, notify Sustainment Maintenance.</p> <p>a. If resistance is as specified, repair or replace connectors (WP 0113 00).</p> <p>b. If engine harness requires replacement, notify Sustainment Maintenance.</p> <p>a. If resistance is as specified, repair or replace connectors (WP 0113 00).</p> <p>b. If engine harness requires replacement, notify Sustainment Maintenance.</p>



350-1292

**Table 3. Error Code 1581 - Fuel Inlet Restriction
Sensor Circuit Failure Troubleshooting Procedures - Continued.**

MALFUNCTION	TEST OR INSPECTION	CORRECTIVE ACTION
<p>Error Code 1581 - Fuel Inlet Restriction Sensor Circuit Failure - Continued.</p>	<p>11. Place ignition switch in OFF position, disconnect actuator harness connector and sensor harness connector from engine ECU, and disconnect fuel inlet restriction sensor from engine harness.</p> <p>a. Measure resistance from actuator harness connector pin 27 to all other pins in actuator connector. Resistance should be greater than 100k Ohms.</p> <p>b. Measure resistance from actuator harness connector pin 27 to all other pins in sensor connector. Resistance should be greater than 100k Ohms.</p> <p>c. Measure resistance from actuator harness connector pin 28 to all other pins in actuator connector. Resistance should be greater than 100k Ohms.</p>	<p>a. If resistance is as specified, replace fuel inlet restriction sensor (WP 0113 00).</p> <p>b. If resistance is not as specified, notify Sustainment Maintenance to replace engine harness.</p> <p>a. If resistance is as specified, replace fuel inlet restriction sensor (WP 0094 00).</p> <p>b. If resistance is not as specified, notify Sustainment Maintenance to replace engine harness.</p> <p>a. If resistance is as specified, replace fuel inlet restriction sensor (WP 0094 00).</p> <p>b. If resistance is not as specified, Notify Sustainment Maintenance to replace engine harness.</p>



350-1293

**Table 3. Error Code 1581 - Fuel Inlet Restriction
Sensor Circuit Failure Troubleshooting Procedures - Continued.**

MALFUNCTION	TEST OR INSPECTION	CORRECTIVE ACTION
<p>Error Code 1581 - Fuel Inlet Restriction Sensor Circuit Failure - Continued.</p>	<p>d. Measure resistance from actuator harness connector pin 29 to all other pins in sensor connector. Resistance should be greater than 100k Ohms.</p> <p>e. Measure resistance from actuator harness connector pin 28 to all other pins in sensor connector. Resistance should be greater than 100k Ohms.</p> <p>f. Measure resistance from actuator harness connector pin 29 to all other pins in actuator connector. Resistance should be greater than 100k Ohms.</p>	<p>a. If resistance is as specified, replace fuel inlet restriction sensor (WP 0094 00).</p> <p>b. If resistance is not as specified, notify Sustainment Maintenance to replace engine harness.</p> <p>a. If resistance is as specified, replace fuel inlet restriction sensor (WP 0094 00).</p> <p>b. If resistance is not as specified, notify Sustainment Maintenance to replace engine harness.</p> <p>a. If resistance is as specified, replace fuel inlet restriction sensor (WP 0094 00).</p> <p>b. If resistance is not as specified, notify Sustainment Maintenance to replace engine harness.</p>

END OF WORK PACKAGE

ENGINE BATTERY VOLTAGE CIRCUITS TROUBLESHOOTING

0025 00

THIS WORK PACKAGE COVERS

Error Code 1434 - Unswitched Battery Supply Circuit Failure

Error Code 1441 - Unswitched Battery Supply Circuit Failure

Error Code 1442 - Unswitched Battery Supply Circuit Failure

Error Code 1474 - Starter Solenoid Lockout Relay Driver Circuit Failure

Error Code 1596 - Voltage Monitor, High Voltage Failure

INITIAL SETUP

Tools and Special Tools

Test Lead, Male (Item 124, WP 0289 00)

References

TM 10-3930-675-10

Current Supply (A34738.0200) (WP 0048 00-31)

NOTE

- Refer to WP 0004 00 for additional troubleshooting guidance, information, and illustrations that locate critical components.
- Refer also to illustrations at end of work package for component location.

Table 1. Error Code 1434 - Unswitched Battery Supply Circuit Failure Troubleshooting Procedures.

MALFUNCTION	TEST OR INSPECTION	CORRECTIVE ACTION
<p>Error Code 1434 - Unswitched Battery Supply Circuit Failure.</p>	<p style="text-align: center;">NOTE</p> <p>Use test lead, male - part number 3822758 (Item 122, WP 0289 00-17) and test lead, female - part number 3822917 (Item 124, WP 0289 00-17) to test the OEM harness connector.</p> <ol style="list-style-type: none"> 1. Check condition and charge of batteries. Check the voltage of each battery while cranking the engine. 2. Ensure circuit breakers F4 and F5 are not tripped. 	<ol style="list-style-type: none"> a. If the battery voltage of any one battery drops below 6V when cranking, service, charge, or replace battery. b. Clean battery connections. <p>Reset circuit breakers as required.</p>

Table 1. Error Code 1434 - Unswitched Battery Supply Circuit Failure Troubleshooting Procedures - Continued.

MALFUNCTION	TEST OR INSPECTION	CORRECTIVE ACTION
<p>Error Code 1434 - Unswitched Battery Supply Circuit Failure - Continued.</p>	<p style="text-align: center;">NOTE</p> <p style="text-align: center;">Error code 1434 can be activated by turning off the master switch when the ignition switch is on.</p> <p>3. Inspect the OEM harness connector and ECU pins for damage, dirt, or corrosion. Remove the engine cover (WP 0148 00). Disconnect the OEM harness connector from ECU (794) (WP 0079 00).</p> <p>4. Check for voltage. Turn the ignition ON and check for voltage (22V to 26V) at the OEM connector harness at pins 7, 8, 17, 18, and 28 (WP 0048 00-10).</p> <p>5. Inspect connector X17 for damage. Access the cab distribution box in the panel behind the operators seat. Pull the box out and disconnect connector X17.</p> <p>6. Check continuity of wires 174, 175, 176, 177, and 179 between X17 and the OEM harness connector (WP 0048 00-10).</p> <p>7. Check for voltage. Disconnect connector X17. Turn the ignition ON. Check voltage (22V to 26V) at the mounted part of X17 at pins 4, 5, 6, 7, and 9 (WP 0048 00-10).</p>	

Table 1. Error Code 1434 - Unswitched Battery Supply Circuit Failure Troubleshooting Procedures - Continued.

MALFUNCTION	TEST OR INSPECTION	CORRECTIVE ACTION
<p>Error Code 1434 - Unswitched Battery Supply Circuit Failure - Continued</p>	<p>8. Check continuity. Disconnect the OEM harness connector from ECU (794). Check continuity to ground at pins 29, 30, 39, 40, and 50 (WP 0048 00-10).</p> <p>9. Check for short (continuity) between pins in the OEM harness. Disconnect X17 and the OEM harness connector. Check for continuity between each listed pin and all of the other pins in the OEM harness connector: 7, 8, 17, 18, 29, 30, 40, and 50 (WP 0048 00-10).</p>	<p>a. If continuity to ground is not found at any one pin; check wire W19 for proper connection on the main grounding stud on the end of the starter.</p> <p>b. Notify Sustainment Maintenance to replace engine and transmission wiring harness.</p> <p>If a short (continuity) found between any two or more pins, notify Sustainment Maintenance to replace engine and transmission wiring harness.</p>

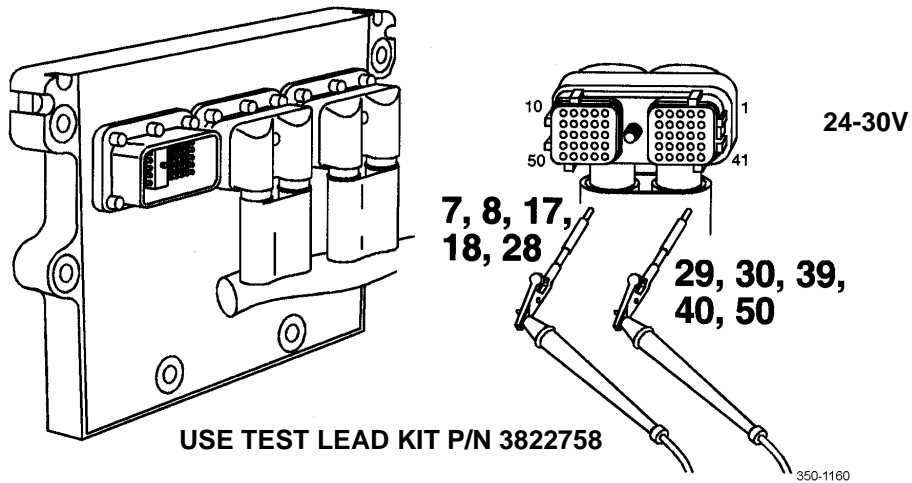


Table 2. Error Code 1441 - Unswitched Battery Supply Circuit Failure Troubleshooting Procedures.

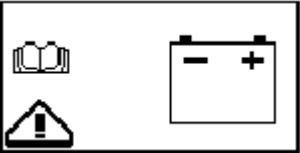
MALFUNCTION	TEST OR INSPECTION	CORRECTIVE ACTION
<p>Error Code 1441 - Unswitched Battery Supply Circuit Failure.</p> 	<p>Perform the troubleshooting procedures for error code 1434.</p>	

Table 3. Error Code 1442 - Unswitched Battery Supply Circuit Failure Troubleshooting Procedures.

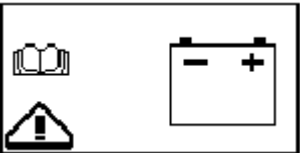
MALFUNCTION	TEST OR INSPECTION	CORRECTIVE ACTION
<p>Error Code 1442 - Unswitched Battery Supply Circuit Failure.</p> 	<p>NOTE</p> <p>Use test lead, male - part number 3822758 (Item 122, WP 0289 00-17) and test lead, female - part number 3822917 (Item 124, WP 0289 00-14) to test the OEM harness connector.</p> <ol style="list-style-type: none"> 1. Check condition and charge of batteries. Check the voltage of each battery while cranking the engine. 2. Check output voltage from alternator. 3. Inspect the OEM harness connector and ECU pins for damage, dirt, or corrosion. Remove the engine cover (WP 0148 00). Disconnect the OEM harness connector from ECU (794) (WP 0079 00). 4. Check for continuity. Disconnect the OEM harness connector from ECU (794). Check continuity to ground at pins 29, 30, 39, 40, and 50 (WP 0048 00-10). 	<p>NOTE</p> <ol style="list-style-type: none"> a. If the battery voltage of any one battery drops below 6V when cranking, service, charge, or replace battery. b. Clean battery connections. <p>If output voltage is higher than 26V, replace alternator (WP0070 00).</p> <ol style="list-style-type: none"> a. Clean and repair connector as required (WP 0113 00 00). b. Replace damaged ECU (794) (WP 0079 00). <ol style="list-style-type: none"> a. If continuity to ground is not found at any one pin, check wire W19 for proper connection on the main grounding stud on the end of the starter. b. Notify Sustainment Maintenance to replace engine and transmission wiring harness.

Table 4. Error Code 1474 - Starter Solenoid Lockout Relay Driver Circuit Failure Troubleshooting Procedures.


MALFUNCTION	TEST OR INSPECTION	CORRECTIVE ACTION
<p data-bbox="159 443 722 499">Error Code 1474 - Starter Solenoid Lockout Relay Driver Circuit Failure.</p> 	<p data-bbox="1045 443 1146 474" style="text-align: center;">NOTE</p> <p data-bbox="781 491 1414 611">Use test lead, male - part number 3822758 (Item 122, WP 0289 00-17) and test lead, female - part number 3822917 (Item 124, WP 0289 00-14) to test the OEM harness connector.</p> <ol style="list-style-type: none"> <li data-bbox="735 722 1089 968">1. Inspect the 31 pin OEM harness connector and pins for damage, dirt, or corrosion. Remove the engine cover (WP 0148 00). Disconnect the 31 pin OEM harness connector from engine harness (WP 0079 00). <li data-bbox="735 993 1089 1239">2. Check for voltage. Disconnect the 31 pin OEM harness connector. Turn the ignition ON and check for voltage (22V-26V) at the loose part of the 31 pin OEM connector harness at pin 20 (WP 0048 00-10). <li data-bbox="735 1264 1089 1446">3. Inspect connector X16 for damage. Access the cab distribution box in the panel behind the operators seat. Pull the 31 pin OEM harness connector (WP 0048 00-31). <li data-bbox="735 1472 1089 1619">4. Check continuity and for continuity to ground of wire 161 between X16 and the 31 pin OEM harness connector (WP 0048 00-31). 	<p data-bbox="1105 722 1458 837">a. Clean and repair connector as required (WP 0113 00). b. Replace damaged ECU (794) (WP 0079 00).</p> <p data-bbox="1105 993 1430 1050">If voltage (22V to 26V) is not found, continue with step 3.</p> <p data-bbox="1105 1264 1398 1320">Repair or replace damaged connector (WP 0113 00).</p> <p data-bbox="1105 1472 1458 1619">If continuity is not found or continuity to ground is found, notify Sustainment Maintenance to replace engine and transmission wiring harness.</p>

Table 4. Error Code 1474 - Starter Solenoid Lockout Relay Driver Circuit Failure Troubleshooting Procedures - Continued.

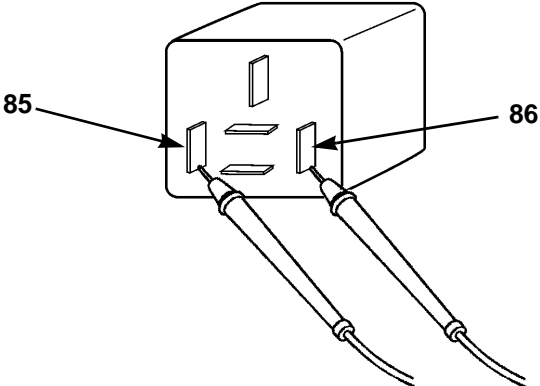
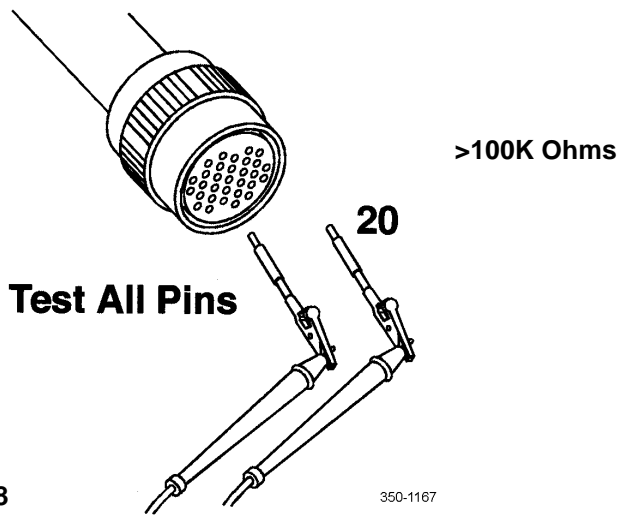
MALFUNCTION	TEST OR INSPECTION	CORRECTIVE ACTION
<p>Error Code 1474 - Starter Solenoid Lockout Relay Driver Circuit Failure - Continued.</p>	<p>5. Check voltage (22V to 26V) at connector X16 pin 1 (WP 0048 00-31). Disconnect connector X16 and turn the ignition ON.</p> <p>6. Check for resistance. Remove relay 330-1 and inspect. Check resistance between 330-1 pins 85 and 86. Should be 290 to 350 Ohms.</p>	<p>Open the cab distribution box to gain access to relay 330-1 (WP 0074 00).</p> <p>If resistance is not as specified, or relay is damaged, replace 330-1 relay (WP 0074 00).</p>
<p>330-1 RELAY</p>  <p>350-1366</p>		
	<p>7. Check for continuity. With the 330-1 relay removed, check continuity at the 330-1 relay socket between pins 85 and XK12 pin 5, and between 86 and XK12 pin 2 (WP 0048 00-31).</p> <p>8. Inspect connectors for damage, dirt, or corrosion. Disconnect the 31 pin OEM harness connector and the actuator harness connector from ECU (794).</p>	<p>a. If continuity is not found at either check, remove the relay board and inspect for damage.</p> <p>b. Replace damaged relay board (WP 0074 00).</p> <p>a. Clean and repair connector as required (WP 0113 00).</p> <p>b. Replace damaged ECU (794) (WP 0079 00).</p>

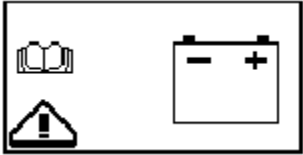
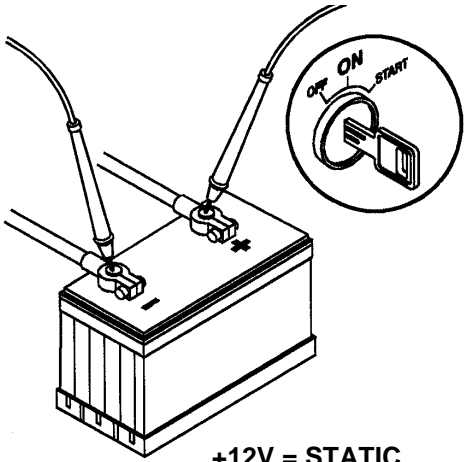
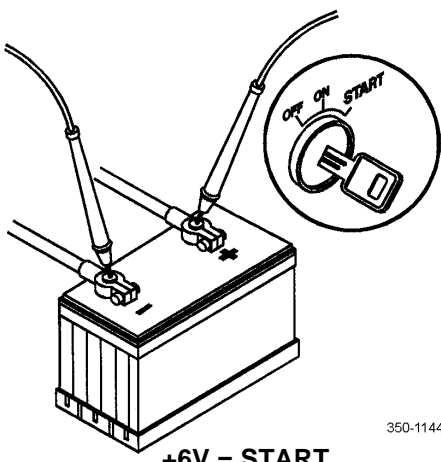
Table 4. Error Code 1474 - Starter Solenoid Lockout Relay Driver Circuit Failure Troubleshooting Procedures - Continued.

MALFUNCTION	TEST OR INSPECTION	CORRECTIVE ACTION
<p>Error Code 1474 - Starter Solenoid Lockout Relay Driver Circuit Failure - Continued.</p>	<p>9. Check continuity and for continuity to ground between the mounted part 31 pin OEM harness connector pin 20 and the actuator harness connector pin 46.</p> <p>10. Check continuity. Disconnect the 31 pin harness connector, actuator harness connector and sensor harness connector. Check for continuity between pin 20 and all of the other pins in the 31 pin OEM harness connector.</p>	<p>If continuity is not found or continuity to ground is found, notify Sustainment Maintenance to replace engine harness.</p> <p>If a short (continuity) is found between any of the pins, notify Sustainment Maintenance to replace engine harness.</p>



USE TEST LEAD KIT P/N 3822758

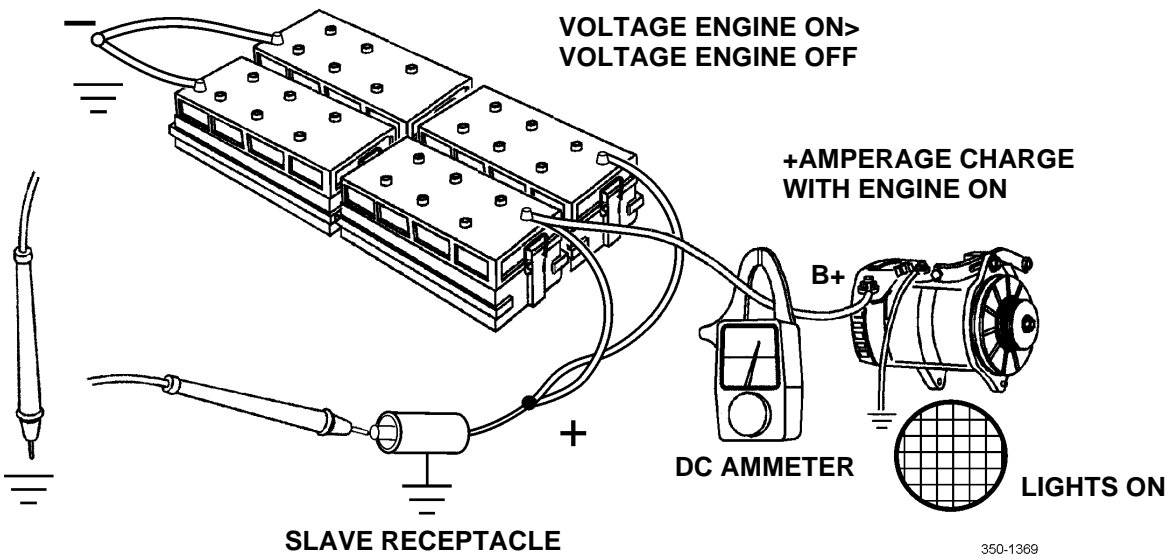
Table 5. Error Code 1596 - Voltage Monitor, High Voltage Failure Troubleshooting Procedures.

MALFUNCTION	TEST OR INSPECTION	CORRECTIVE ACTION
<p data-bbox="155 411 727 464">Error Code 1596 - Voltage Monitor, High Voltage Failure</p>  <div style="display: flex; justify-content: space-around; align-items: center;">   </div> <p data-bbox="565 1560 756 1587">+12V = STATIC</p> <p data-bbox="1013 1560 1182 1587">+6V = START</p>	<ol style="list-style-type: none"> <li data-bbox="735 411 1089 499">1. Check battery and alternator cable connections for loose connections and corrosion. <li data-bbox="735 520 1089 737">2. Turn ignition switch to OFF position and measure battery voltage from positive (+) terminal to negative (-) terminal. Voltage should be at least 12V. Check each battery in system. <li data-bbox="735 758 1089 1073">3. Turn ignition switch to OFF position and measure battery voltage from positive (+) terminal to negative (-) terminal. Voltage should be +12V. Check voltage while trying to start engine. Voltage should be at least +6V during cranking. Check each battery in system. 	<p data-bbox="1097 411 1451 499">Tighten battery connections and clean battery terminals as required.</p> <p data-bbox="1097 520 1451 611">If voltage is not as required, charge or replace battery (WP 0108 00).</p> <p data-bbox="1097 758 1451 848">If voltage is not as required, charge or replace battery (WP 0108 00).</p>

350-1144

Table 5. Error Code 1596 - Voltage Monitor, High Voltage Failure Troubleshooting Procedures - Continued.

MALFUNCTION	TEST OR INSPECTION	CORRECTIVE ACTION
<p>Error Code 1596 - Voltage Monitor, High Voltage Failure - Continued.</p>	<p>4. Place ignition switch in OFF position and install ammeter between alternator and battery. Perform the following to check charging rate of alternator.</p> <ul style="list-style-type: none"> a. Check battery voltage at slave receptacle with engine off. b. Start engine and recheck voltage. Voltage should be slightly higher than voltage checked with engine off. c. Turn on lights. Check amperage reading on ammeter with engine on. Ammeter should have a positive (more or less) reading depending on charge of batteries. 	<p>If alternator is not charging properly, replace alternator (WP 0070 00).</p>



END OF WORK PACKAGE

TRANSMISSION TEMPERATURE TROUBLESHOOTING

0026 00

THIS WORK PACKAGE COVERS

Error Code 637 - Transmission Sump Temperature Sensor Failure, Open Circuit or Short Circuit to Battery

Error Code 638 - Transmission Sump Temperature Sensor Failure, Short Circuit to Chassis

Error Code 639 - Converter Output Temperature Sensor Failure, Open Circuit or Short Circuit to Battery

Error Code 640 - Converter Output Temperature Sensor Failure, Short Circuit to Chassis

Error Code 783 - Sump Temperature Critical Threshold [212°F (100°C)] Failure

Error Code 795 - Converter Output Temperature Critical Threshold [248°F (120°C)] Failure

INITIAL SETUP

References

TM 10-3930-675-10

ECU Transmission (A34650.0200) (WP 0048 00-12)


Equipment Condition

Cab moved to transport position (TM 10-3930-675-10)

NOTE

- Refer to WP 0004 00 for additional troubleshooting guidance, information, and illustrations that locate critical components.
- Refer also to illustration at end of work package for component location.

Table 1. Error Code 637 - Transmission Sump Temperature Sensor Failure, Open Circuit or Short Circuit to Battery Troubleshooting Procedures.

MALFUNCTION	TEST OR INSPECTION	CORRECTIVE ACTION
<p>Error Code 637 - Transmission Sump Temperature Sensor Failure, Open Circuit or Short Circuit to Battery.</p> 	<ol style="list-style-type: none"> 1. Check resistance. Disconnect connector X172 located in the middle panel behind the operator's seat. Check resistance at the loose part of connector X172 between pins 8 and 9 (WP 0048 00-15). The resistance should be 800 to 1,500 Ohms. 2. Inspect connector. Disconnect and inspect connector 827 located on the top of the transmission. Check resistance at the mounted part of connector 827 between pins 8 and 9 (WP 0048 00-15). The resistance should be 800 to 1,500 Ohms. 	<p>If resistance is not as specified, move the cab to the transport position (TM 10-3930-675-10) and remove the transmission front access cover (WP 0142 00).</p> <p>If resistance is not as specified, or the 827 connector is damaged, replace the transmission (WP 0224 00).</p>

TRANSMISSION TEMPERATURE TROUBLESHOOTING - CONTINUED

0026 00

Table 1. Error Code 637 - Transmission Sump Temperature Sensor Failure, Open Circuit or Short Circuit to Battery Troubleshooting Procedures - Continued.

MALFUNCTION	TEST OR INSPECTION	CORRECTIVE ACTION
<p>Error Code 637 - Transmission Sump Temperature Sensor Failure, Open Circuit or Short Circuit to Battery - Continued.</p>	<p>3. Inspect the 827 connector and pins for damage and proper connection. Check continuity of wires 1728 and 1729 (WP 0048 00-15).</p> <p>4. Check continuity. Disconnect ECU (793). Check the connector and ECU pins 39 and 46 for damage. Check continuity of wires A1728 and A1729A (WP 0048 00-15).</p>	<p>If continuity is not present in either wire, or connector 827 is damaged, notify Sustainment Maintenance to replace engine and transmission wiring harness.</p> <p>a. Repair or replace damaged connector (WP 0113 00). b. Replace damaged ECU (793) (WP 0080 00). c. Replace open or shorted wire.</p>

Table 2. Error Code 638 - Transmission Sump Temperature Sensor Failure, Short Circuit to Chassis Troubleshooting Procedures.


MALFUNCTION	TEST OR INSPECTION	CORRECTIVE ACTION
<p>Error Code 638 - Transmission Sump Temperature Sensor Failure, Short Circuit to Chassis.</p> 	<p>1. Check connector and pins. Disconnect connector X172 located in the middle panel behind the operator's seat. Check resistance at the loose part of connector X172 between pins 8 and 9 and check pin for continuity to ground (WP 0048 00-15). Resistance should be 800 to 1,500 Ohms and there should be no continuity to ground.</p> <p>2. Check connector and pins. Disconnect and inspect connector 827 located on the top of the transmission. Check resistance at the mounted part of connector 827 between pins 8 and 9 and check pin for continuity to ground (WP 0048 00-15). Resistance should be 800 to 1,500 Ohms and there should be no continuity to ground.</p>	<p>If resistance is not as specified, or continuity to ground is present, move the cab to the transport position (TM 10-3930-675-10) and remove the transmission front access cover (WP 0142 00).</p> <p>If resistance is not as specified, continuity to ground is present, or the 827 connector is damaged, replace the transmission (WP 0224 00).</p>

Table 2. Error Code 638 - Transmission Sump Temperature Sensor Failure, Short Circuit to Chassis Troubleshooting Procedures - Continued.

MALFUNCTION	TEST OR INSPECTION	CORRECTIVE ACTION
<p>Error Code 638 - Transmission Sump Temperature Sensor Failure, Short Circuit to Chassis - Continued.</p>	<p>3. Inspect the 827 connector and pins for damage and proper connection. Check continuity and for continuity to ground of wires 1728 and 1729 (WP 0048 00-15).</p> <p>4. Check for continuity. Disconnect ECU (793). Check the connector and ECU pins 39 and 46 for damage. Check continuity and for continuity to ground of wires 1728 and A1729A (WP 0048 00-15).</p>	<p>If continuity is not present in either wire, continuity to ground is present, or connector 827 is damaged, notify Sustainment Maintenance to replace engine and transmission wiring harness.</p> <p>a. Repair or replace damaged connector (WP 0113 00). b. Replace damaged ECU (793) (WP 0080 00). c. Replace open or grounded wire.</p>

Table 3. Error Code 639 - Converter Output Temperature Sensor Failure, Open Circuit, or Short Circuit to Battery Troubleshooting Procedures.


MALFUNCTION	TEST OR INSPECTION	CORRECTIVE ACTION
<p>Error Code 639 - Converter Output Temperature Sensor Failure, Open Circuit or Short Circuit to Battery.</p> 	<p>1. Check resistance. Disconnect connector X172 located in the middle panel behind the operator's seat. Check resistance at the loose part of connector X172 between pins 12 and 13 (WP 0048 00-15). Resistance should be 10k to 200k Ohms.</p> <p>2. Check resistance. Disconnect and inspect the 766 temperature sensor located on the transmission bell housing. Check resistance of the 766 temperature sensor between the two pins (WP 0048 00-15). The resistance should be 10k to 200k Ohms.</p> <p>3. Inspect the 766 connector and pins for damage and proper connection. Check continuity of wires 17212 and 17213 (WP 0048 00-15).</p>	<p>If resistance is not as specified, move the cab to the transport position (TM 10-3930-675-10) and remove the transmission front access cover (WP 0142 00).</p> <p>If resistance is not as specified, or the 766 temperature sensor is damaged, replace the 766 temperature sensor (WP 0096 00).</p> <p>If continuity is not present in either wire or connector 766 is damaged, notify Sustainment Maintenance to replace engine and transmission wiring harness.</p>

Table 3. Error Code 639 - Converter Output Temperature Sensor Failure, Open Circuit, or Short Circuit to Battery Troubleshooting Procedures - Continued.

MALFUNCTION	TEST OR INSPECTION	CORRECTIVE ACTION
Error Code 639 - Converter Output Temperature Sensor Failure, Open Circuit or Short Circuit to Battery - Continued.	4. Check connector and pins. Disconnect ECU (793). Check the connector and ECU pins 46 and 49 for damage. Check continuity of wires A1729A, A1729B, and A17212 (WP 0048 00-15).	a. Repair or replace damaged connector (WP 0113 00). b. Replace damaged ECU (793) (WP 0080 00). c. Replace open or shorted wire.

Table 4. Error Code 640 - Converter Output Temperature Sensor Failure, Short Circuit to Chassis Troubleshooting Procedures.


MALFUNCTION	TEST OR INSPECTION	CORRECTIVE ACTION
Error Code 640 - Converter Output Temperature Sensor Failure, Short Circuit to Chassis. 	<ol style="list-style-type: none"> 1. Check connector and pins. Disconnect connector X172 located in the middle panel behind the operator's seat. Check resistance at the loose part of connector X172 between pins 12 and 13 and check pin for continuity to ground (WP 0048 00-15). Resistance should be 10k to 200k Ohms and there should be no continuity to ground. 2. Check connector and pins. Disconnect and inspect the 766 temperature sensor located on the transmission bell housing. Check resistance of the 766 temperature sensor between the two pins and check pin for continuity to ground (WP 0048 00-15). Resistance should be 10k to 200k Ohms and there should be no continuity to ground. 3. Inspect the 766 connector and pins for damage and proper connection. Check continuity and for continuity to ground of wires 17212 and 17213 (WP 0048 00-15). 	<p>If resistance is not as specified, or continuity to ground is present, move the cab to the transport position (TM 10-3930-675-10) and remove the transmission front access cover (WP 0142 00).</p> <p>If resistance is not as specified, continuity to ground is present, or the 766 temperature sensor is damaged, replace the 766 temperature sensor (WP 0096 00).</p> <p>If continuity is not present in either wire, continuity to ground is present or connector 766 is damaged, notify Sustainment Maintenance to replace engine and transmission wiring harness.</p>

Table 4. Error Code 640 - Converter Output Temperature Sensor Failure, Short Circuit to Chassis Troubleshooting Procedures - Continued.

MALFUNCTION	TEST OR INSPECTION	CORRECTIVE ACTION
Error Code 640 - Converter Output Temperature Sensor Failure, Short Circuit to Chassis - Continued.	4. Check connector and pins. Disconnect ECU (793). Check the connector and ECU pins 46 and 49 for damage. Check continuity and for continuity to ground of wires A1729A, A1729B, and A17212 (WP 0048 00-15).	a. Repair or replace damaged connector (WP 0113 00). b. Replace damaged ECU (793) (WP 0080 00). c. Replace open or grounded wire.

Table 5. Error Code 783 - Sump Temperature Critical Threshold [212°F (100°C)] Failure Troubleshooting Procedures.



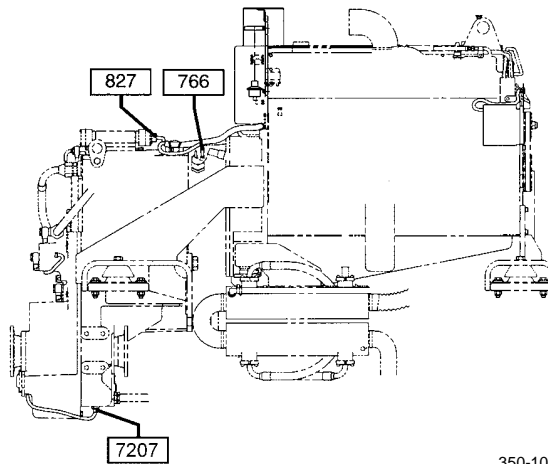
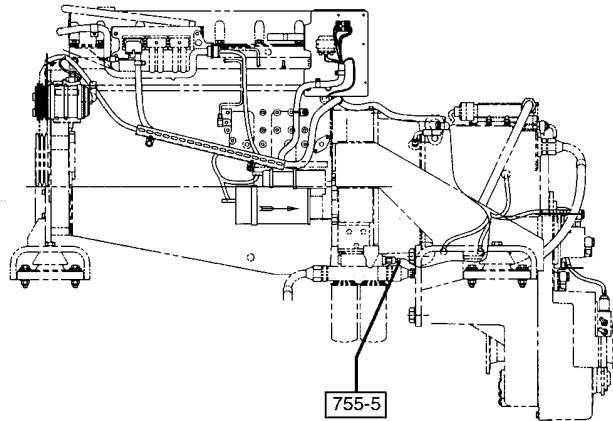
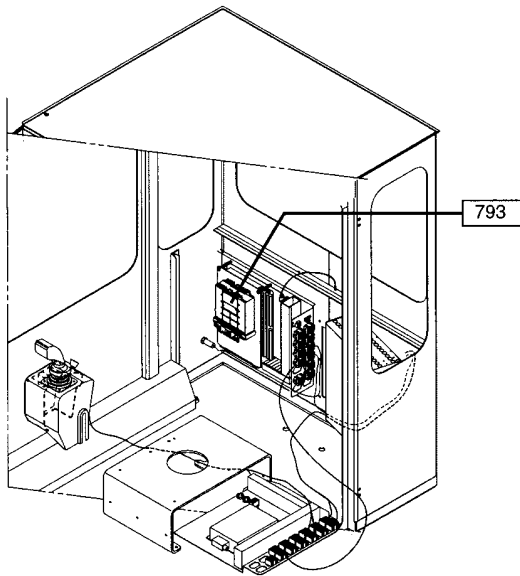
MALFUNCTION	TEST OR INSPECTION	CORRECTIVE ACTION
<p>Error Code 783 - Sump Temperature Critical Threshold [212°F (100°C)] Failure.</p> 	<ol style="list-style-type: none"> 1. Allow engine and transmission to cool. 2. Check coolant level (TM 10-3930-675-10). 3. Check radiator top and side grille for mud, snow, or obstructions. 4. Check loose coolant hoses and clamps. 5. With engine idling, transmission selector lever in N (Neutral) position, parking brake applied, and engine at operating temperature, check transmission fluid level (TM 10-3930-675-10). 6. Enter "DIAG EXTRA FUNCT" 4(13) menu and check water level sensor setting. Enter "1" to shut off and "0" to run cooling fan. Check if fording water level sensor is clogged or damaged. 	<p>Add coolant as required (TM 10-3930-675-10).</p> <p>Clear obstructions.</p> <p>Tighten or replace as required (WP 0065 00 and WP 0115 00).</p> <p>Add transmission fluid as required (TM 10-3930-675-10).</p> <p>Clean and/or replace fording water level sensor (WP 0091 00).</p>

Table 6. Error Code 795 - Converter Output Temperature Critical Threshold [248°F (120°C)] Failure Troubleshooting Procedures.

MALFUNCTION	TEST OR INSPECTION	CORRECTIVE ACTION
<p>Error Code 795 - Converter Output Temperature Critical Threshold [248°F (120°C)] Failure.</p> 	<ol style="list-style-type: none"> 1. Allow engine and transmission to cool. 2. Check coolant level (TM 10-3930-675-10-1). 3. Check radiator top and side grille for mud, snow, or obstructions. 4. Check loose coolant hoses and clamps. 5. With engine idling, transmission selector lever in N (Neutral) position, parking brake applied, and engine at operating temperature, check transmission fluid level (TM 10-3930-675-10-1). 6. Enter "DIAG EXTRA FUNCT" 4(13) menu and check water level sensor setting. Enter "1" to shut off and "0" to run cooling fan. Check if fording water level sensor is clogged or damaged. 	<p>Add coolant as required (TM 10-3930-675-10-1).</p> <p>Clear obstructions.</p> <p>Tighten or replace as required (WP 0065 00 and WP 0115 00).</p> <p>Add transmission fluid as required (TM 10-3930-675-10-1).</p> <p>Clean and/or replace fording water level sensor (WP 0091 00).</p>



350-1041

END OF WORK PACKAGE

TRANSMISSION SPEED SENSORS TROUBLESHOOTING

0027 00**THIS WORK PACKAGE COVERS**

Error Code 649 - Engine Speed Sensor Failure, Open Circuit or Short Circuit to Battery

Error Code 650 - Engine Speed Sensor Failure, Short Circuit to Chassis

Error Code 651 - Engine Speed Sensor Failure, Logical Error

Error Code 652 - Turbine Speed Sensor Failure, Open Circuit or Short Circuit to Battery

Error Code 653 - Turbine Speed Sensor Failure, Short Circuit to Chassis

Error Code 654 - Turbine Speed Sensor Failure, Logical Error

Error Code 655 - Internal Speed Sensor Failure, Open Circuit or Short Circuit to Battery

Error Code 656 - Internal Speed Sensor Failure, Short Circuit to Chassis

Error Code 657 - Internal Speed Sensor Failure, Logical Error

Error Code 658 - Output Speed Sensor Failure, Open Circuit or Short Circuit to Battery

Error Code 659 - Output Speed Sensor Failure, Short Circuit to Chassis

Error Code 660 - Output Speed Sensor Failure, Logical Error

Error Code 662 - Output Speed Sensor Failure, Logical Speed Error

INITIAL SETUP**References**

TM 10-3930-675-10

ECU Transmission (A34650.0200) (WP 0048 00-12)

NOTE

- Refer to WP 0004 00 for additional troubleshooting guidance, information, and illustrations that locate critical components.
- Refer also to illustration at end of work package for component location.

Table 1. Error Code 649 - Engine Speed Sensor Failure, Open Circuit or Short Circuit to Battery Troubleshooting Procedures.


MALFUNCTION	TEST OR INSPECTION	CORRECTIVE ACTION
<p>Error Code 649 - Engine Speed Sensor Failure, Open Circuit or Short Circuit to Battery.</p> 	<ol style="list-style-type: none"> 1. Check resistance. Disconnect connector X173 located in the middle panel behind the operators seat. Check resistance at the loose part of connector X173 between pins 4 and 5 (WP 0048 00-14). Resistance should be 950 to 1,150 Ohms. 2. Check resistance. Disconnect and inspect the 761 engine speed sensor located on the left side of the transmission. Check resistance of the 761 engine speed sensor between the two pins (WP 0048 00-14). Resistance should be 950 to 1,150 Ohms. 3. Inspect the 761 connector and pins for damage and proper connection. Check continuity of wires 1734 and 1735 (WP 0048 00-14). 4. Check connector and pins. Disconnect ECU (793). Check the connector and ECU pins 3 and 19 for damage. Check continuity of wires A1734 and A1735A (WP 0048 00-14). 	<p>If resistance is not as specified, move the cab to the transport position (TM 10-3930-675-10) and remove the transmission front access cover (WP 0142 00).</p> <p>If resistance is not as specified or the 761 engine speed sensor is damaged, replace the 761 engine speed sensor (WP 0094 00).</p> <p>If continuity is not present in either wire or connector 761 is damaged, notify Sustainment Maintenance to replace engine and transmission wiring harness.</p> <ol style="list-style-type: none"> a. Repair or replace damaged connector (WP 0113 00). b. Replace damaged ECU (793) (WP 0080 00). c. Replace open or shorted wire.

Table 2. Error Code 650 - Engine Speed Sensor Failure, Short Circuit to Chassis Troubleshooting Procedures.


MALFUNCTION	TEST OR INSPECTION	CORRECTIVE ACTION
<p>Error Code 650 - Engine Speed Sensor Failure, Short Circuit to Chassis.</p> 	<ol style="list-style-type: none"> 1. Check connector and pins. Disconnect connector X173 located in the middle panel behind the operator's seat. Check resistance at the loose part of connector X173 between pins 4 and 5 and check pin for continuity to ground (WP 0048 00-14). The resistance should be 950 to 1,150 Ohms with no continuity to ground. 2. Check resistance. Disconnect and inspect the 761 engine speed sensor located on the left side of the transmission. Check resistance of the 761 engine speed sensor between the two pins and check pin for continuity to ground (WP 0048 00-14). Resistance should be 950 to 1,150 Ohms with no continuity to ground. 3. Inspect the 761 connector and pins for damaged and proper connection. Check continuity to ground of wires 1734 and 1735 (WP 0048 00-14). 4. Check connector and pins. Disconnect ECU (793). Check the connector and ECU pins 3 and 19 for damage. Check continuity and continuity to ground of wires A1734 and A1735A (WP 0048 00-14). 	<p>If resistance is not as specified or continuity to ground is present, move the cab to the transport position (TM 10-39030-675-10) and remove the transmission front access cover (WP 0142 00).</p> <p>If resistance is not as specified, continuity to ground is present, or the 761 engine speed sensor is damaged, replace the 761 engine speed sensor (WP 0094 00).</p> <p>If continuity is not present in either wire, continuity to ground is present, or connector 761 is damaged, notify Sustainment Maintenance to replace engine and transmission wiring harness.</p> <ol style="list-style-type: none"> a. Repair or replace damaged connector (WP 0113 00). b. Replace damaged ECU (793) (WP 0080 00). c. Replace open or grounded wire.

Table 3. Error Code 651 - Engine Speed Sensor Failure, Logical Error Troubleshooting Procedures.


MALFUNCTION	TEST OR INSPECTION	CORRECTIVE ACTION
<p>Error Code 651 - Engine Speed Sensor Failure, Logical Error.</p> 	<p>Place ignition switch in OFF position for 30 seconds and then back in ON position.</p>	<p>If error code is still present, perform troubleshooting procedures for error code 649.</p>

Table 4. Error Code 652 - Turbine Speed Sensor Failure, Open Circuit or Short Circuit to Battery Troubleshooting Procedures.


MALFUNCTION	TEST OR INSPECTION	CORRECTIVE ACTION
<p>Error Code 652 - Turbine Speed Sensor Failure, Open Circuit or Short Circuit to Battery.</p> 	<ol style="list-style-type: none"> 1. Check connector and pins. Disconnect connector X173 located in the middle panel behind the operator seat. Check resistance at the loose part of connector X173 between pins 6 and 7 (WP 0048 00-14). Resistance should be 950 to 1,150 Ohms. 2. Check resistance. Disconnect and inspect the 751 turbine speed sensor located on the left side of the transmission. Check resistance of the 751 turbine speed sensor between the two pins (WP 0048 00-14). Resistance should be 950 to 1,150 Ohms. 3. Inspect the 751 connector and pins for damaged and proper connection. Check continuity of wires 1736 and 1737 (WP 0048 00-14). 	<p>If resistance is not as specified, move the cab to the transport position (TM 10-3930-675-10) and remove the transmission front access cover (WP 0142 00).</p> <p>If resistance is not as specified or the 751 turbine speed sensor is damaged, replace the 751 turbine speed sensor (WP 0096 00).</p> <p>If continuity is not present in either wire or connector 751 is damaged, notify Sustainment Maintenance to replace engine and transmission wiring harness.</p>

Table 4. Error Code 652 - Turbine Speed Sensor Failure, Open Circuit or Short Circuit to Battery Troubleshooting Procedures - Continued.

MALFUNCTION	TEST OR INSPECTION	CORRECTIVE ACTION
<p>Error Code 652 - Turbine Speed Sensor Failure, Open Circuit or Short Circuit to Battery - Continued.</p>	<p>4. Check continuity. Disconnect ECU (793). Check the connector and ECU pins 3 and 41 for damage. Check continuity of wires A1736, A1735A, and A1735B (WP 0048 00-14).</p>	<p>a. Repair or replace damaged connector (WP 0113 00). b. Replace damaged ECU (793) (WP 0080 00). c. Replace open or shorted wire.</p>

Table 5. Error Code 653 - Turbine Speed Sensor Failure, Short Circuit to Chassis Troubleshooting Procedures.


MALFUNCTION	TEST OR INSPECTION	CORRECTIVE ACTION
<p>Error Code 653 - Turbine Speed Sensor Failure, Short Circuit to Chassis.</p> 	<ol style="list-style-type: none"> 1. Check connector and pins. Disconnect connector X173 located in the middle panel behind the operator's seat. Check resistance at the loose part of connector X173 between pins 6 and 7 and check pin for continuity to ground (WP 0048 00-14). Resistance should be 950 to 1,150 Ohms with no continuity to ground. 2. Inspect sensor. Disconnect and inspect the 751 turbine speed sensor located on the left side of the transmission. Check resistance of the 751 turbine speed sensor between the two pins and check pin for continuity to ground (WP 0048 00-14). Resistance should be 950 to 1,150 Ohms with no continuity to ground. 3. Inspect the 751 connector and pins for damage and proper connection. Check continuity and for continuity to ground of wires 1736 and 1737 (WP 0048 00-14). 4. Check connector and pins. Disconnect ECU (793). Check the connector and ECU pins 3 and 41 for damage. Check continuity and for continuity to ground of wires A1736, A1735A, and A1735B (WP 0048 00-14). 	<p>If resistance is not as specified or continuity to ground is present, move the cab to the transport position (TM 10-3930-675-10) and remove the transmission front access cover (WP 0142 00).</p> <p>If resistance is not as specified, continuity to ground is present, or the 751 turbine speed sensor is damaged, replace the 751 turbine speed sensor (WP 0096 00).</p> <p>If continuity is not present in either wire, continuity to ground is present, or connector 751 is damaged, notify Sustainment Maintenance to replace engine and transmission wiring harness.</p> <ol style="list-style-type: none"> a. Repair or replace damaged connector (WP 0113 00). b. Replace damaged ECU (793) (WP 0080 00). c. Replace open or grounded wire.

Table 6. Error Code 654 - Turbine Speed Sensor Failure, Logical Error Troubleshooting Procedures.


MALFUNCTION	TEST OR INSPECTION	CORRECTIVE ACTION
<p>Error Code 654 - Turbine Speed Sensor Failure, Logical Error.</p> 	<p>Place ignition switch in OFF position for 30 seconds and then back in ON position.</p>	<p>If error code is still present, perform troubleshooting procedures for error code 652.</p>

Table 7. Error Code 655 - Internal Speed Sensor Failure, Open Circuit or Short Circuit to Battery Troubleshooting Procedures.


MALFUNCTION	TEST OR INSPECTION	CORRECTIVE ACTION
<p>Error Code 655 - Internal Speed Sensor Failure, Open Circuit or Short Circuit to Battery.</p> 	<ol style="list-style-type: none"> 1. Check resistance. Disconnect connector X173 located in the middle panel behind the operators seat. Check resistance at the loose part of connector X173 between pins 8 and 9 (WP 0048 00-14). Resistance should be 950 to 1,150 Ohms. 2. Check sensor. Disconnect and inspect the 752 internal gear speed sensor located on the left side of the transmission. Check resistance of the 752 internal gear speed sensor between the two pins (WP 0048 00-14). Resistance should be 950 to 1,150 Ohms. 3. Inspect the 752 connector and pins for damage and proper connection. Check continuity of wires 1738 and 1739 (WP 0048 00-14). 	<p>If resistance is not as specified, move the cab to the transport position (TM 10-3930-675-10) and remove the transmission front access cover (WP 0142 00).</p> <p>If resistance is not as specified or the 752 internal gear speed sensor is damaged, replace the 752 internal gear speed sensor (WP 0096 00).</p> <p>If continuity is not present in either wire or connector 752 is damaged, notify Sustainment Maintenance to replace engine and transmission wiring harness.</p>

Table 7. Error Code 655 - Internal Speed Sensor Failure, Open Circuit or Short Circuit to Battery Troubleshooting Procedures - Continued.

MALFUNCTION	TEST OR INSPECTION	CORRECTIVE ACTION
Error Code 655 - Internal Speed Sensor Failure, Open Circuit or Short Circuit to Battery - Continued.	4. Check connector and pins. Disconnect ECU (793). Check the connector and ECU pins 3 and 42 for damage. Check continuity of wires A1738, A1735A, A1735B, and A1735C (WP 0048 00-14).	a. Repair or replace damaged connector (WP 0113 00). b. Replace damaged ECU (793) (WP 0080 00). c. Replace open or shorted wire.

Table 8. Error Code 656 - Internal Speed Sensor Failure, Short Circuit to Chassis Troubleshooting Procedures.


MALFUNCTION	TEST OR INSPECTION	CORRECTIVE ACTION
Error Code 656 - Internal Speed Sensor Failure, Short Circuit to Chassis. 	<ol style="list-style-type: none"> 1. Disconnect connector X173 located in the middle panel behind the operator's seat. Check resistance at the loose part of connector X173 between pins 8 and 9 and check pin for continuity to ground (WP 0048 00-14). Resistance should be 950 to 1,150 Ohms with no continuity to ground. 2. Check sensor and pins. Disconnect and inspect the 752 internal gear speed sensor located on the left side of the transmission. Check resistance of the 752 internal gear speed sensor between the two pins and check pin for continuity to ground (WP 0048 00-14). Resistance should be 950 to 1,150 Ohms with no continuity to ground. 3. Inspect the 752 connector and pins for damage and proper connection. Check continuity and for continuity to ground of wires 1738 and 1739 (WP 0048 00-14). 	<p>If resistance is not as specified or continuity to ground is present, move the cab to the transport position (TM 10-3930-675-10) and remove the transmission front access cover (WP 0142 00).</p> <p>If resistance is not as specified, continuity to ground is present, or the 752 internal gear speed sensor is damaged, replace the 752 internal gear speed sensor (WP 0096 00).</p> <p>If continuity is not present in either wire, continuity to ground is present, or connector 752 is damaged, notify Sustainment Maintenance to replace engine and transmission wiring harness.</p>

Table 8. Error Code 656 - Internal Speed Sensor Failure, Short Circuit to Chassis Troubleshooting Procedures - Continued.

MALFUNCTION	TEST OR INSPECTION	CORRECTIVE ACTION
Error Code 656 - Internal Speed Sensor Failure, Short Circuit to Chassis - Continued.	4. Check connector and pins. Disconnect ECU (793). Check the connector and ECU pins 3 and 42 for damage. Check continuity and for continuity to ground of wires A1738, A1735A, and A1735C (WP 0048 00-14).	a. Repair or replace damaged connector (WP 0113 00). b. Replace damaged ECU (793) (WP 0080 00). c. Replace open or grounded wire.

Table 9. Error Code 657 - Internal Speed Sensor Failure, Logical Error Troubleshooting Procedures.


MALFUNCTION	TEST OR INSPECTION	CORRECTIVE ACTION
Error Code 657 - Internal Speed Sensor Failure, Logical Error. 	Place ignition switch in OFF position for 30 seconds and then back in ON position.	If error code is still present, perform troubleshooting procedures for error code 655.

Table 10. Error Code 658 - Output Speed Sensor Failure, Open Circuit or Short Circuit to Battery Troubleshooting Procedures.


MALFUNCTION	TEST OR INSPECTION	CORRECTIVE ACTION
Error Code 658 - Output Speed Sensor Failure, Open Circuit or Short Circuit to Battery. 	1. Ensure circuit breaker F28 is not tripped. 2. Check for voltage. Access middle panel behind seat and disconnect X173. Turn the ignition on and check voltage (24V) on the mounted part of X173 pin 3 to ground. 3. Check connector. Disconnect and inspect the 760 output speed sensor located on the back side of the transmission (WP 0048 00-14).	Reset circuit breaker. a. If no voltage (24V) is found, check continuity of wires A472, 472 (WP 0048 00-32), A1742B (WP 0048 00-12), and A1742C (WP 0048 00-14). b. Repair or replace damaged connector (WP 0113 00). c. Replace open or shorted wire. If the 760 output speed sensor is damaged, replace the 760 output speed sensor (WP 0096 00).

Table 10. Error Code 658 - Output Speed Sensor Failure, Open Circuit or Short Circuit to Battery Troubleshooting Procedures - Continued.

MALFUNCTION	TEST OR INSPECTION	CORRECTIVE ACTION
<p>Error Code 658 - Output Speed Sensor Failure, Open Circuit or Short Circuit to Battery - Continued.</p>	<p>4. Inspect the 760 connector and pins for damage and proper connection. Check continuity of wires 1731, 1732, and 1733 (WP 0048 00-14).</p> <p>5. Check connector and pins. Disconnect ECU (793). Check the connector and ECU pins 4 and 62 for damage. Check continuity of wires A1731 and A1732 (WP 0048 00-14).</p>	<p>If continuity is not present in any one wire or connector 761 is damaged, notify Sustainment Maintenance to replace engine and transmission wiring harness.</p> <p>a. Repair or replace damaged connector (WP 0113 00). b. Replace damaged ECU (793) (WP 0080 00). c. Replace open or shorted wire. d. Replace the 760 output speed sensor (WP 0096 00).</p>

Table 11. Error Code 659 - Output Speed Sensor Failure, Short Circuit to Chassis Troubleshooting Procedures.


MALFUNCTION	TEST OR INSPECTION	CORRECTIVE ACTION
<p>Error Code 659 - Output Speed Sensor Failure, Short Circuit to Chassis.</p> 	<p>1. Ensure circuit breaker F28 is not tripped.</p> <p>2. Check for voltage. Access middle panel behind seat and disconnect X173. Turn the ignition on and check voltage (24V) on the mounted part of X173 pin 3 to ground.</p> <p>3. Check for continuity. Disconnect and inspect the 760 output speed sensor located on the back side of the transmission (WP 0048 00-14). Check each pin of the sensor for continuity to ground.</p>	<p>Reset circuit breaker.</p> <p>a. If no voltage (24V) is found, check continuity and continuity to ground of wires A472, 472 (WP 0048 00-32), A1742B (WP 0048 00-12), and A1742C (WP 0048 00-14). b. Repair or replace damaged connector (WP 0113 00). c. Replace open or grounded wire.</p> <p>If the 760 output speed sensor is damaged or grounded, replace the 760 output speed sensor (WP 0096 00).</p>

Table 11. Error Code 659 - Output Speed Sensor Failure, Short Circuit to Chassis Troubleshooting Procedures - Continued.

MALFUNCTION	TEST OR INSPECTION	CORRECTIVE ACTION
Error Code 659 - Output Speed Sensor Failure, Short Circuit to Chassis - Continued.	<p>4. Check connector and pins. Inspect the 760 connector and pins for damage and proper connection. Check continuity and for continuity to ground of wires 1731, 1732, and 1733 (WP 0048 00-14).</p> <p>5. Check connector pins and wires. Disconnect ECU (793). Check the connector and ECU pins 4 and 62 for damage. Check continuity and for continuity to ground of wires A1731 and A1732 (WP 0048 00-14).</p>	<p>If continuity is not present in any one wire, continuity to ground is present, or connector 760 is damaged, notify Sustainment Maintenance to replace engine and transmission wiring harness.</p> <p>a. Repair or replace damaged connector (WP 0113 00). b. Replace damaged ECU (793) (WP 0080 00). c. Replace open or grounded wire. d. Replace the 760 output speed sensor (WP 0096 00).</p>

Table 12. Error Code 660 - Output Speed Sensor Failure, Logical Error Troubleshooting Procedures.



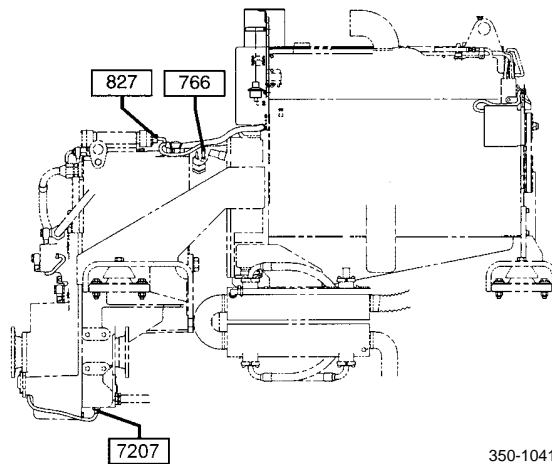
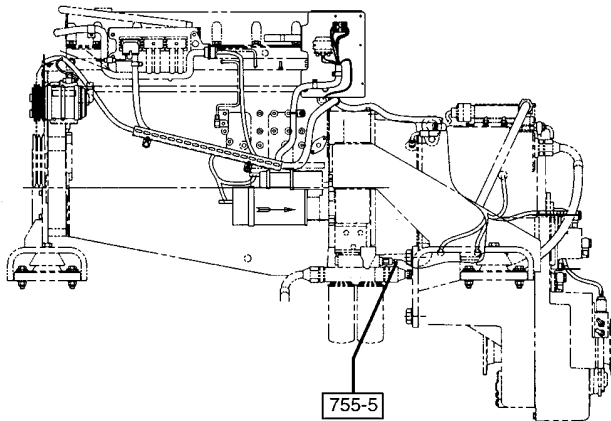
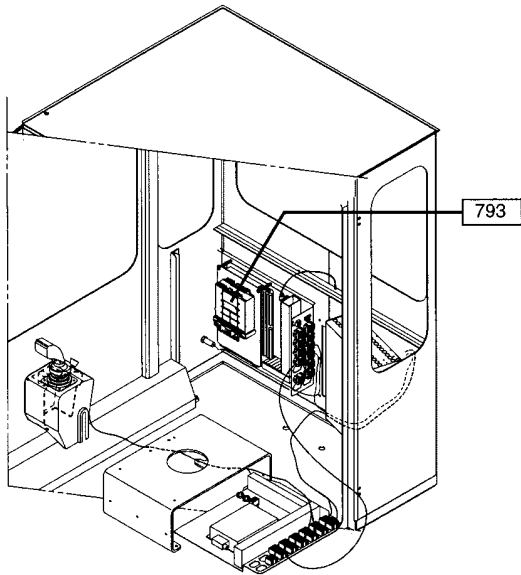
MALFUNCTION	TEST OR INSPECTION	CORRECTIVE ACTION
Error Code 660 - Output Speed Sensor Failure, Logical Error. 	<p>Place ignition switch in OFF position for 30 seconds and then back in ON position.</p>	<p>If error code is still present, perform troubleshooting procedures for error code 658.</p>

Table 13. Error Code 662 - Output Speed Sensor Failure, Logical Speed Error Troubleshooting Procedures.

MALFUNCTION	TEST OR INSPECTION	CORRECTIVE ACTION
Error Code 662 - Output Speed Sensor Failure, Logical Speed Error. 	<p>Place ignition switch in OFF position for 30 seconds and then back in ON position.</p>	<p>If error code is still present, perform troubleshooting procedures for error code 652, error code 655, and/or error code 658.</p>



350-1041

END OF WORK PACKAGE

TRANSMISSION CLUTCH CIRCUIT TROUBLESHOOTING

0028 00

THIS WORK PACKAGE COVERS

Error Code 713 - Clutch K1 Short Circuit to Battery Failure

Error Code 714 - Clutch K1 Short Circuit to Chassis Failure

Error Code 715 - Clutch K1 Open Circuit Failure

Error Code 716 - Clutch K2 Short Circuit to Battery Failure

Error Code 717 - Clutch K2 Short Circuit to Chassis Failure

Error Code 718 - Clutch K2 Open Circuit Failure

Error Code 719 - Clutch K3 Short Circuit to Battery Failure

Error Code 720 - Clutch K3 Short Circuit to Chassis Failure

Error Code 721 - Clutch K3 Open Circuit Failure

Error Code 729 - Clutch K4 Short Circuit to Battery Failure

Error Code 730 - Clutch K4 Short Circuit to Chassis Failure

Error Code 731 - Clutch K4 Open Circuit Failure

Error Code 732 - Clutch KV Short Circuit to Battery Failure

Error Code 733 - Clutch KV Short Circuit to Chassis Failure

Error Code 734 - Clutch KV Open Circuit Failure

Error Code 735 - Clutch KR Short Circuit to Battery Failure

Error Code 736 - Clutch KR Short Circuit to Chassis Failure

Error Code 737 - Clutch KR Open Circuit Failure

INITIAL SETUP

References

TM 10-3930-675-10

ECU Transmission (A34650.0200) (WP 0048 00-12)

NOTE

Refer to WP 0004 00 for additional troubleshooting guidance, information, and illustrations that locate critical components.

Table 1. Error Code 713 - Clutch K1 Short Circuit to Chassis Failure Troubleshooting Procedures.

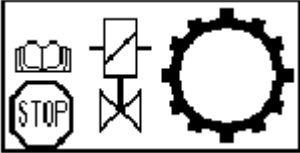
MALFUNCTION	TEST OR INSPECTION	CORRECTIVE ACTION
<p data-bbox="159 407 717 470">Error Code 713 - Clutch K1 Short Circuit to Battery Failure.</p> 	<ol style="list-style-type: none"> <li data-bbox="730 407 1089 695">1. Check for resistance. Disconnect connector X172 located in the middle panel behind the operator's seat. Check resistance at the loose part of connector X172 between pins 3 and 7 (WP 0048 00-15). Resistance should be 18 to 20 Ohms. <li data-bbox="730 709 1089 997">2. Check for resistance. Disconnect and inspect connector 827 located on the top of the transmission. Check resistance at the mounted part of connector 827 between pins 3 and 7 (WP 0048 00-15). Resistance should be 18 to 20 Ohms. <li data-bbox="730 1012 1089 1171">3. Inspect the 827 connector and pins for damage and proper connection. Check continuity of wires 1723 and 1727 (WP 0048 00-15). <li data-bbox="730 1186 1089 1409">4. Check continuity between the loose part of X172 pin 3 and each other pin of X172. First, ensure connectors X172 and 827 are disconnected. There should not be continuity between the pins. <li data-bbox="730 1423 1089 1646">5. Check connector, pins, and wires. Disconnect ECU (793). Check the connector and ECU pins 12, 13, and 32 for damage. Check continuity of wires A1723, A1727A, and A1727b (WP 0048 00-15). 	<p data-bbox="1102 407 1461 567">If resistance is not as specified, move the cab to the transport position (TM 10-3930-675-10) and remove the transmission front access cover (WP 0142 00).</p> <p data-bbox="1102 709 1461 835">If resistance is not as specified or the 827 connector is damaged, replace the transmission (WP 0224 00).</p> <p data-bbox="1102 1012 1461 1171">If continuity is not present in either wire or connector 827 is damaged, replace engine and transmission wiring harness (WP 0113 00).</p> <p data-bbox="1102 1186 1461 1346">If continuity is present in any pin combination continuity check, replace shorted engine and transmission wiring harness (WP 0113 00).</p> <ol style="list-style-type: none"> <li data-bbox="1102 1423 1461 1486">a. Repair or replace damaged connector (WP 0113 00). <li data-bbox="1102 1486 1461 1549">b. Replace damaged ECU (793) (WP 0080 00). <li data-bbox="1102 1549 1461 1581">c. Replace open or shorted wire.

Table 2. Error Code 714 - Clutch K1 Short Circuit to Chassis Failure Troubleshooting Procedures.

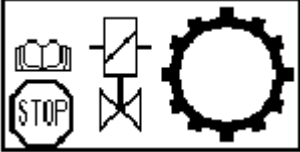
MALFUNCTION	TEST OR INSPECTION	CORRECTIVE ACTION
<p data-bbox="159 407 717 468">Error Code 714 - Clutch K1 Short Circuit to Chassis Failure.</p> 	<ol style="list-style-type: none"> <li data-bbox="730 407 1089 695">1. Check connector and pins. Disconnect connector X172 located in the middle seat panel behind the operator's seat. Check for continuity to ground at the loose part of connector X172 at pins 3 and 7 (WP 0048 00-15). There should not be continuity to ground. <li data-bbox="730 709 1089 1031">2. Check for continuity. Disconnect and inspect connector 827 located on the top of the transmission. Check continuity at the mounted part of connector 827 between pin 3 and ground and pin 7 and ground (WP 0048 00-15). There should not be continuity to ground. <li data-bbox="730 1045 1089 1234">3. Inspect the 827 connector and pins for damage and proper connection. Check for continuity to ground for wires 1723 and 1727 (WP 0048 00-15). <li data-bbox="730 1249 1089 1570">4. Check for continuity. Disconnect ECU (793) and connector X172. Check the connector and ECU pins 12, 13, and 32 for damage. Check for continuity to ground for wires A1723, A1727A, and A1727B (WP 0048 00-15). There should not be continuity to ground. 	<p data-bbox="1102 407 1461 569">If continuity to ground is found, move the cab to the transport position (TM 10-3930-675-10) and remove the transmission front access cover (WP 0142 00).</p> <p data-bbox="1102 709 1461 835">If continuity to ground is found or the 827 connector is damaged, replace the transmission (WP 0224 00).</p> <p data-bbox="1102 1045 1461 1199">If continuity to ground is present in either wire or connector 827 is damaged, replace grounded engine and transmission wiring harness (WP 0113 00).</p> <ol style="list-style-type: none"> <li data-bbox="1102 1249 1461 1312">a. Repair or replace damaged connector (WP 0113 00). <li data-bbox="1102 1312 1461 1375">b. Replace damaged ECU (793) (WP 0080 00). <li data-bbox="1102 1375 1461 1438">c. Replace open or grounded wire.

Table 3. Error Code 715 - Clutch K1 Open Circuit Failure Troubleshooting Procedures.

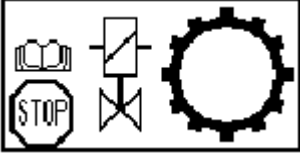
MALFUNCTION	TEST OR INSPECTION	CORRECTIVE ACTION
<p data-bbox="159 407 717 436">Error Code 715 - Clutch K1 Open Circuit Failure.</p> 	<ol style="list-style-type: none"> <li data-bbox="730 407 1089 688">1. Check resistance. Disconnect connector X172 located in the middle panel behind the operator's seat. Check resistance at the loose part of connector X172 between pins 3 and 7 (WP 0048 00-15). Resistance should be 18 to 29 Ohms. <li data-bbox="730 709 1089 991">2. Check resistance. Disconnect and inspect connector 827 located on the top of the transmission. Check resistance at the mounted part of connector 827 between pins 3 and 7 (WP 0048 00-15). Resistance should be 18 to 20 Ohms. <li data-bbox="730 1012 1089 1167">3. Inspect the 827 connector and pins for damage and proper connection. Check continuity of wires 1723 and 1727 (WP 0048 00-15). <li data-bbox="730 1188 1089 1409">4. Check connector, pins, and wires. Disconnect ECU (793). Check the connector and ECU pins 12, 13, and 32 for damage. Check continuity of wires A1723, A1727A, and A1727B (WP 0048 00-15). 	<p data-bbox="1102 407 1461 562">If resistance is not as specified, move the cab to the transport position (TM 10-3930-675-10) and remove the transmission front access cover (WP 0142 00).</p> <p data-bbox="1102 709 1461 835">If resistance is not as specified or the 827 connector is damaged, replace the transmission (WP 0224 00).</p> <p data-bbox="1102 1012 1461 1167">If continuity is not present in either wire or connector 827 is damaged, replace engine and transmission wiring harness (WP 0113 00).</p> <ol style="list-style-type: none"> <li data-bbox="1102 1188 1461 1251">a. Repair or replace damaged connector (WP 0113 00). <li data-bbox="1102 1251 1461 1314">b. Replace damaged ECU (793) (WP 0080 00). <li data-bbox="1102 1314 1461 1377">c. Replace open, damaged, or shorted wire.

Table 4. Error Code 716 - Clutch K2 Short Circuit to Battery Failure Troubleshooting Procedures.

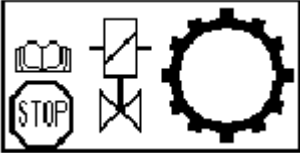
MALFUNCTION	TEST OR INSPECTION	CORRECTIVE ACTION
<p data-bbox="159 409 719 472">Error Code 716 - Clutch K2 Short Circuit to Battery Failure.</p> 	<ol style="list-style-type: none"> <li data-bbox="732 409 1088 693">1. Check connector and pins. Disconnect connector X172 located in the middle panel behind the operator's seat. Check resistance at the loose part of connector X172 between pins 6 and 7 (WP 0048 00-15). Resistance should be 18 to 20 Ohms. <li data-bbox="732 703 1088 987">2. Check connector and pins. Disconnect and inspect connector 827 located on the top of the transmission. Check resistance at the mounted part of connector 87 between pins 6 and 7 (WP 0048 00-15). Resistance should be 18 to 20 Ohms. <li data-bbox="732 997 1088 1165">3. Inspect the 827 connector and pins for damage and proper connection. Check continuity of wires 1726 and 1727 (WP 0048 00-15). <li data-bbox="732 1176 1088 1438">4. Check for continuity. Ensure connector X172 and 827 are disconnected. Check continuity between the loose part of X172 pin 6 and each other pin of X172. There should not be continuity between the pins. <li data-bbox="732 1449 1088 1669">5. Check for continuity. Disconnect ECU (793). Check the connector and ECU pins 12, 13, and 51 for damage. Check continuity of wires A1726, A1727A, and A1727B (WP 0048 00-15). 	<p data-bbox="1104 409 1461 556">If resistance is not as specified, move the cab to the transport position (TM 10-3930-675-10) and remove the transmission front access cover (WP 0142 00).</p> <p data-bbox="1104 703 1461 829">If resistance is not as specified or the 827 connector is damaged, replace the transmission (WP 0224 00).</p> <p data-bbox="1104 997 1461 1165">If continuity is not present in either wire or connector 827 is damaged, replace engine and transmission wiring harness (WP 0113 00).</p> <p data-bbox="1104 1176 1461 1344">If continuity is present in any pin combination continuity check, replace shorted engine and transmission wiring harness (WP 0113 00).</p> <ol style="list-style-type: none"> <li data-bbox="1104 1449 1461 1512">a. Repair or replace damaged connector (WP 0113 00). <li data-bbox="1104 1512 1461 1575">b. Replace damaged ECU (793) (WP 0080 00). <li data-bbox="1104 1575 1461 1617">c. Replace open or shorted wire.

Table 5. Error Code 717 - Clutch K2 Short Circuit to Chassis Failure Troubleshooting Procedures.

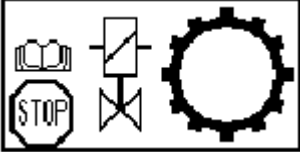
MALFUNCTION	TEST OR INSPECTION	CORRECTIVE ACTION
<p data-bbox="159 407 717 468">Error Code 717 - Clutch K2 Short Circuit to Chassis Failure.</p> 	<ol style="list-style-type: none"> <li data-bbox="730 407 1089 695">1. Check for continuity. Disconnect connector X172 located in the middle panel behind the operator's seat. Check for continuity to ground at the loose part of connector X172 at pins 6 and 7 (WP 0048 00-15). There should not be continuity to ground. <li data-bbox="730 709 1089 1031">2. Check for continuity. Disconnect and inspect connector 827 located on the top of the transmission. Check continuity at the mounted part of connector 827 between pin 6 and ground and pin 7 and ground (WP 0048 00-15). There should not be continuity to ground. <li data-bbox="730 1045 1089 1234">3. Inspect the 827 connector and pins for damage and proper connection. Check for continuity to ground for wires 1726 and 1727 (WP 0048 00-15). <li data-bbox="730 1249 1089 1570">4. Check for continuity. Disconnect ECU (793) and connector X172. Check the connector and ECU pins 12, 13, and 51 for damage. Check for continuity to ground for wires A1726, A1727A, and A1727B (WP 0048 00-15). There should not be continuity to ground. 	<p data-bbox="1102 407 1461 569">If continuity to ground is found, move the cab to the transport position (TM 10-330-675-10) and remove the transmission front access cover (WP 0142 00).</p> <p data-bbox="1102 709 1461 835">If continuity to ground is found or the 827 connector is damaged, replace the transmission (WP 0224 00).</p> <p data-bbox="1102 1045 1461 1199">If continuity to ground is present in either wire or connector 827 is damaged, replace grounded engine and transmission wiring harness (WP 0113 00).</p> <ol style="list-style-type: none"> <li data-bbox="1102 1249 1461 1312">a. Repair or replace damaged connector (WP 0113 00). <li data-bbox="1102 1312 1461 1375">b. Replace damaged ECU (793) (WP 0080 00). <li data-bbox="1102 1375 1461 1438">c. Replace open or grounded wire.

Table 6. Error Code 718 - Clutch K2 Open Circuit Failure Troubleshooting Procedures.

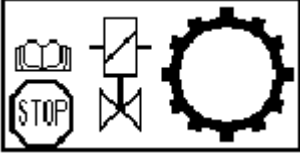
MALFUNCTION	TEST OR INSPECTION	CORRECTIVE ACTION
<p data-bbox="159 409 717 438">Error Code 718 - Clutch K2 Open Circuit Failure.</p> 	<ol style="list-style-type: none"> <li data-bbox="730 409 1089 695">1. Check for resistance. Disconnect connector X172 located in the middle panel behind the operator's seat. Check resistance at the loose part of connector X172 between pins 6 and 7 (WP 0048 00-15). Resistance should be 18 to 29 Ohms. <li data-bbox="730 709 1089 995">2. Check for resistance. Disconnect and inspect connector 827 located on the top of the transmission. Check resistance at the mounted part of connector 827 between pins 6 and 7 (WP 0048 00-15). Resistance should be 18 to 29 Ohms. <li data-bbox="730 1010 1089 1171">3. Inspect the 827 connector and pins for damage and proper connection. Check continuity of wires 1726 and 1727 (WP 0048 00-15). <li data-bbox="730 1186 1089 1409">4. Check for continuity. Disconnect ECU (793). Check the connector and ECU pins 12, 13, and 51 for damage. Check continuity of wires A1726, A1727A, and A1727B (WP 0048 00-15). 	<p data-bbox="1102 409 1466 571">If resistance is not as specified, move the cab to the transport position (TM 10-3930-675-10) and remove the transmission front access cover (WP 0142 00).</p> <p data-bbox="1102 709 1466 835">If resistance is not as specified or the 827 connector is damaged, replace the transmission (WP 0224 00).</p> <p data-bbox="1102 1010 1466 1171">If continuity is not present in either wire or connector 827 is damaged, replace engine and transmission wiring harness (WP 0113 00).</p> <ol style="list-style-type: none"> <li data-bbox="1102 1186 1466 1251">a. Repair or replace damaged connector (WP 0113 00). <li data-bbox="1102 1251 1466 1316">b. Replace damaged ECU (793) (WP 0080 00). <li data-bbox="1102 1316 1466 1381">c. Replace open, damaged, or shorted wire.

Table 7. Error Code 719 - Clutch K3 Open Circuit to Battery Failure Troubleshooting Procedures.

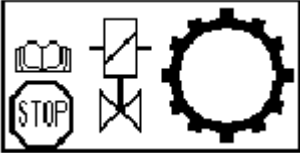
MALFUNCTION	TEST OR INSPECTION	CORRECTIVE ACTION
<p data-bbox="159 407 717 470">Error Code 719 - Clutch K3 Open Circuit to Battery Failure.</p> 	<ol style="list-style-type: none"> <li data-bbox="730 407 1091 695">1. Check for resistance. Disconnect connector X172 located in the middle panel behind the operator's seat. Check resistance at the loose part of connector X172 between pins 4 and 7 (WP 0048 00-15). Resistance should be 18 to 20 Ohms. <li data-bbox="730 709 1091 997">2. Check for resistance. Disconnect and inspect connector 827 located on the top of the transmission. Check resistance at the mounted part of connector 827 between pins 4 and 7 (WP 0048 00-15). Resistance should be 18 to 20 Ohms. <li data-bbox="730 1012 1091 1199">3. Check for continuity. Inspect the 827 connector and pins for damage and proper connection. Check continuity of wires 1724 and 1727 (WP 0048 00-15). <li data-bbox="730 1213 1091 1472">4. Check for continuity. Ensure connectors X172 and 827 are disconnected. Check continuity between the loose part of X172 pin 4 and each other pin of X172. There should not be continuity between the pins. <li data-bbox="730 1486 1091 1709">5. Check for continuity. Disconnect ECU (793). Check the connector and ECU pins 12, 13, and 55 for damage. Check continuity of wires A1724, A1727A, and A1727B (WP 0048 00-15). 	<p data-bbox="1104 407 1461 569">If resistance is not as specified, move the cab to the transport position (TM 10-3930-675-10) and remove the transmission front access cover (WP 0142 00).</p> <p data-bbox="1104 709 1461 842">If resistance is not as specified or the 827 connector is damaged, replace the transmission (WP 0224 00).</p> <p data-bbox="1104 1012 1461 1171">If continuity is not present in either wire or connector 827 is damaged, replace engine and transmission wiring harness (WP 0113 00).</p> <p data-bbox="1104 1213 1461 1373">If continuity is present in any pin combination continuity check, replace shorted engine and transmission wiring harness (WP 0113 00).</p> <ol style="list-style-type: none"> <li data-bbox="1104 1486 1461 1549">a. Repair or replace damaged connector (WP 0113 00). <li data-bbox="1104 1549 1461 1612">b. Replace damaged ECU (793) (WP 0080 00). <li data-bbox="1104 1612 1461 1646">c. Replace open or shorted wire.

Table 8. Error Code 720 - Clutch K3 Short Circuit to Chassis Failure Troubleshooting Procedures.

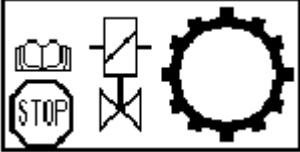
MALFUNCTION	TEST OR INSPECTION	CORRECTIVE ACTION
<p data-bbox="159 407 717 468">Error Code 720 - Clutch K3 Short Circuit to Chassis Failure.</p> 	<ol style="list-style-type: none"> <li data-bbox="730 407 1089 695">1. Check for continuity. Disconnect connector X172 located in the middle panel behind the operator's seat. Check for continuity to ground at the loose part of connector X172 at pins 4 and 7 (WP 0048 00-15). There should not be continuity to ground. <li data-bbox="730 709 1089 1031">2. Check for continuity. Disconnect and inspect connector 827 located on the top of the transmission. Check continuity at the mounted part of connector 827 between pin 4 and ground and pin 7 and ground (WP 0048 00-15). There should not be continuity to ground. <li data-bbox="730 1045 1089 1199">3. Inspect the 827 connector and pins for damage and proper connection. Check continuity of wires 1724 and 1727 (WP 0048 00-15). <li data-bbox="730 1213 1089 1535">4. Check for continuity. Disconnect ECU (793) and connector X172. Check the connector and ECU pins 12, 13, and 55 for damage. Check for continuity to ground for wires A1724, A1727A, and A1727B (WP 0048 00-15). There should not be continuity to ground. 	<p data-bbox="1102 407 1461 569">If continuity to ground is found, move the cab to the transport position (TM 10-3930-675-10) and remove the transmission front access cover (WP 0142 00).</p> <p data-bbox="1102 709 1461 835">If continuity to ground is found or the 827 connector is damaged, replace the transmission (WP 0224 00).</p> <p data-bbox="1102 1045 1461 1199">If continuity is present in either wire or connector 827 is damaged, replace grounded engine and transmission wiring harness (WP 0113 00).</p> <ol style="list-style-type: none"> <li data-bbox="1102 1213 1461 1276">a. Repair or replace damaged connector (WP 0113 00). <li data-bbox="1102 1276 1461 1339">b. Replace damaged ECU (793) (WP 0080 00). <li data-bbox="1102 1339 1461 1402">c. Replace open or grounded wire.

Table 9. Error Code 721 - Clutch K3 Open Circuit Failure Troubleshooting Procedures.

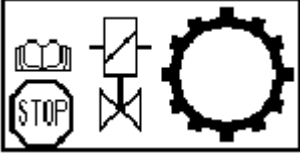
MALFUNCTION	TEST OR INSPECTION	CORRECTIVE ACTION
<p data-bbox="159 407 717 436">Error Code 721 - Clutch K3 Open Circuit Failure.</p> 	<ol style="list-style-type: none"> <li data-bbox="730 407 1091 688">1. Check for resistance. Disconnect connector X172 located in the middle panel behind the operator's seat. Check resistance at the loose part of connector X172 between pins 4 and 7 (WP 0048 00-15). Resistance should be 18 to 20 Ohms. <li data-bbox="730 709 1091 991">2. Check for resistance. Disconnect and inspect connector 827 located on the top of the transmission. Check resistance at the mounted part of connector 827 between pins 4 and 7 (WP 0048 00-15). Resistance should be 18 to 20 Ohms. <li data-bbox="730 1012 1091 1167">3. Inspect the 827 connector and pins for damage and proper connection. Check continuity of wires 1724 and 1727 (WP 0048 00-15). <li data-bbox="730 1188 1091 1411">4. Check for continuity. Disconnect ECU (793). Check the connector and ECU pins 12, 13, and 55 for damage. Check continuity of wires A1724, A1727A, and A1727B (WP 0048 00-15). 	<p data-bbox="1104 407 1461 562">If resistance is not as specified, move the cab to the transport position (TM 10-3930-675-10) and remove the transmission front access cover (WP 0142 00).</p> <p data-bbox="1104 709 1461 831">If resistance is not as specified or the 827 connector is damaged, replace the transmission (WP 0224 00).</p> <p data-bbox="1104 1012 1461 1167">If continuity is not present in either wire or connector 827 is damaged, replace engine and transmission wiring harness (WP 0113 00).</p> <ol style="list-style-type: none"> <li data-bbox="1104 1188 1461 1251">a. Repair or replace damaged connector (WP 0113 00). <li data-bbox="1104 1251 1461 1314">b. Replace damaged ECU (793) (WP 0080 00). <li data-bbox="1104 1314 1461 1377">c. Replace open, damaged, or shorted wire.

Table 10. Error Code 729 - Clutch K4 Short Circuit to Battery Failure Troubleshooting Procedures.

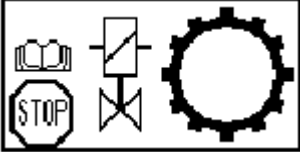
MALFUNCTION	TEST OR INSPECTION	CORRECTIVE ACTION
<p data-bbox="159 409 719 472">Error Code 729 - Clutch K4 Short Circuit to Battery Failure.</p> 	<ol style="list-style-type: none"> <li data-bbox="732 409 1088 693">1. Check for resistance. Disconnect connector X172 located in the middle panel behind the operator's seat. Check resistance at the loose part of connector X172 between pins 2 and 7 (WP 0048 00-15). Resistance should be 18 to 20 Ohms. <li data-bbox="732 703 1088 987">2. Check for resistance. Disconnect and inspect connector 827 located on the top of the transmission. Check resistance at the mounted part of connector 827 between pins 2 and 7 (WP 0048 00-15). Resistance should be 18 to 20 Ohms. <li data-bbox="732 997 1088 1165">3. Inspect the 827 connector and pins for damage and proper connection. Check continuity of wires 1722 and 1727 (WP 0048 00-15). <li data-bbox="732 1176 1088 1438">4. Check for continuity. Ensure connectors X172 and 827 are disconnected. Check continuity between the loose part of X172 pin 2 and each other pin of X172. There should not be continuity between the pins. <li data-bbox="732 1449 1088 1669">5. Check for continuity. Disconnect ECU (793). Check the connector and ECU pins 12, 13, and 51 for damage. Check continuity of wires A1722, A1727A, and A1727B (WP 0048 00-15). 	<p data-bbox="1104 409 1461 567">If resistance is not as specified, move the cab to the transport position (TM 10-3930-675-10) and remove the transmission front access cover (WP 0142 00).</p> <p data-bbox="1104 703 1461 840">If resistance is not as specified or the 827 connector is damaged, replace the transmission (WP 0224 00).</p> <p data-bbox="1104 997 1461 1165">If continuity is not present in either wire or connector 827 is damaged, replace engine and transmission wiring harness (WP 0113 00).</p> <p data-bbox="1104 1176 1461 1344">If continuity is present in any pin combination continuity check, replace shorted engine and transmission wiring harness (WP 0113 00).</p> <ol style="list-style-type: none"> <li data-bbox="1104 1449 1461 1522">a. Repair or replace damaged connector (WP 0113 00). <li data-bbox="1104 1522 1461 1585">b. Replace damaged ECU (793) (WP 0080 00). <li data-bbox="1104 1585 1461 1617">c. Replace open or shorted wire.

Table 11. Error Code 730 - Clutch K4 Short Circuit to Chassis Failure Troubleshooting Procedures.

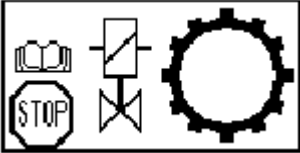
MALFUNCTION	TEST OR INSPECTION	CORRECTIVE ACTION
<p data-bbox="159 407 717 468">Error Code 730 - Clutch K4 Short Circuit to Chassis Failure.</p> 	<ol style="list-style-type: none"> <li data-bbox="730 407 1089 695">1. Check for continuity. Disconnect connector X172 located in the middle panel behind the operator's seat. Check for continuity to ground at the loose part of connector X172 at pins 2 and 7 (WP 0048 00-15). There should not be continuity to ground. <li data-bbox="730 709 1089 1031">2. Check for continuity. Disconnect and inspect connector 827 located on the top of the transmission. Check continuity at the mounted part of connector 827 between pin 2 and ground and pin 7 and ground (WP 0048 00-15). There should not be continuity to ground. <li data-bbox="730 1045 1089 1234">3. Inspect the 827 connector and pins for damage and proper connection. Check for continuity to ground for wires 1722 and 1727 (WP 0048 00-15). <li data-bbox="730 1249 1089 1570">4. Check for continuity. Disconnect ECU (793) and connector X172. Check the connector and ECU pins 12, 13, and 56 for damage. Check for continuity to ground for wires A1722, A1727A, and A1727B (WP 0048 00-15). There should not be continuity to ground. 	<p data-bbox="1102 407 1466 569">If continuity to ground is found, move the cab to the transport position (TM 10-3930-675-10) and remove the transmission front access cover (WP 0142 00).</p> <p data-bbox="1102 709 1466 835">If continuity to ground is found or the 827 connector is damaged, replace the transmission (WP 0224 00).</p> <p data-bbox="1102 1045 1466 1199">If continuity to ground is present in either wire or connector 827 is damaged, replace grounded engine and transmission wiring harness (WP 0113 00).</p> <ol style="list-style-type: none"> <li data-bbox="1102 1249 1466 1312">a. Repair or replace damaged connector (WP 0113 00). <li data-bbox="1102 1312 1466 1375">b. Replace damaged ECU (793) (WP 0080 00). <li data-bbox="1102 1375 1466 1438">c. Replace open or grounded wire.

Table 12. Error Code 731 - Clutch K4 Open Circuit Failure Troubleshooting Procedures.

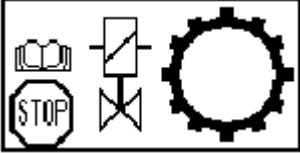
MALFUNCTION	TEST OR INSPECTION	CORRECTIVE ACTION
<p data-bbox="159 409 717 438">Error Code 731 - Clutch K4 Open Circuit Failure.</p> 	<ol style="list-style-type: none"> <li data-bbox="730 409 1089 688">1. Check for resistance. Disconnect connector X172 located in the middle panel behind the operator's seat. Check resistance at the loose part of connector X172 between pins 2 and 7 (WP 0048 00-15). Resistance should be 18 to 20 Ohms. <li data-bbox="730 709 1089 989">2. Check for resistance. Disconnect and inspect connector 827 located on the top of the transmission. Check resistance at the mounted part of connector 827 between pins 2 and 7 (WP 0048 00-15). Resistance should be 18 to 20 Ohms. <li data-bbox="730 1010 1089 1163">3. Inspect the 827 connector and pins for damage and proper connection. Check continuity of wires 1722 and 1727 (WP 0048 00-15). <li data-bbox="730 1184 1089 1402">4. Check for continuity. Disconnect ECU (793). Check the connector and ECU pins 12, 13, and 56 for damage. Check continuity of wires A1722, A1727A, and A1727B (WP 0048 00-15). 	<p data-bbox="1102 409 1461 562">If resistance is not as specified, move the cab to the transport position (TM 10-3930-675-10) and remove the transmission front access cover (WP 0142 00).</p> <p data-bbox="1102 709 1461 831">If resistance is not as specified or the 827 connector is damaged, replace the transmission (WP 0224 00).</p> <p data-bbox="1102 1010 1461 1163">If continuity is not present in either wire or connector 827 is damaged, replace engine and transmission wiring harness (WP 0113 00).</p> <ol style="list-style-type: none"> <li data-bbox="1102 1184 1461 1245">a. Repair or replace damaged connector (WP 0113 00). <li data-bbox="1102 1245 1461 1306">b. Replace damaged ECU (793) (WP 0080 00). <li data-bbox="1102 1306 1461 1367">c. Replace open, damaged, or shorted wire.

Table 13. Error Code 732 - Clutch KV Short Circuit to Battery Failure Troubleshooting Procedures.

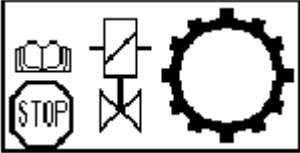
MALFUNCTION	TEST OR INSPECTION	CORRECTIVE ACTION
<p data-bbox="159 407 717 470">Error Code 732 - Clutch KV Short Circuit to Battery Failure.</p> 	<ol style="list-style-type: none"> <li data-bbox="730 407 1089 695">1. Check for resistance. Disconnect connector X172 located in the middle panel behind the operator's seat. Check resistance at the loose part of connector X172 between pins 5 and 7 (WP 0048 00-15). Resistance should be 18 to 20 Ohms. <li data-bbox="730 709 1089 997">2. Check for resistance. Disconnect and inspect connector 827 located on the top of the transmission. Check resistance at the mounted part of connector 827 between pins 5 and 7 (WP 0048 00-15). Resistance should be 18 to 20 Ohms. <li data-bbox="730 1012 1089 1171">3. Inspect the 827 connector and pins for damaged and proper connection. Check continuity of wires 1725 and 1727 (WP 0048 00-15). <li data-bbox="730 1186 1089 1444">4. Check for continuity. Ensure connector X172 and 827 are disconnected. Check continuity between the loose part of X172 pin 5 and each other pin of X172. There should not be continuity between the pins. <li data-bbox="730 1459 1089 1682">5. Check for continuity. Disconnect ECU (793). Check the connector and ECU pins 12, 13, and 9 for damage. Check continuity of wires A1725, A1727A, and A1727B (WP 0048 00-15). 	<p data-bbox="1102 407 1461 567">If resistance is not as specified, move the cab to the transport position (TM 10-3930-675-10) and remove the transmission front access cover (WP 0142 00).</p> <p data-bbox="1102 709 1461 840">If resistance is not as specified or the 827 connector is damaged, replace the transmission (WP 0224 00).</p> <p data-bbox="1102 1012 1461 1171">If continuity is not present in either wire or connector 827 is damaged, replace engine and transmission wiring harness (WP 0113 00).</p> <p data-bbox="1102 1186 1461 1346">If continuity is present in any pin combination continuity check, replace shorted engine and transmission wiring harness (WP 0113 00).</p> <ol style="list-style-type: none"> <li data-bbox="1102 1459 1461 1522">a. Repair or replace damaged connector (WP 0113 00). <li data-bbox="1102 1522 1461 1585">b. Replace damaged ECU (793) (WP 0080 00). <li data-bbox="1102 1585 1461 1617">c. Replace open or shorted wire.

Table 14. Error Code 733 - Clutch KV Short Circuit to Chassis Failure Troubleshooting Procedures.

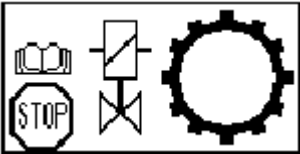
MALFUNCTION	TEST OR INSPECTION	CORRECTIVE ACTION
<p data-bbox="147 401 724 472">Error Code 733 - Clutch KV Short Circuit to Chassis Failure.</p> 	<ol style="list-style-type: none"> <li data-bbox="724 401 1096 693">1. Check for continuity. Disconnect connector X172 located in the middle panel behind the operator's seat. Check for continuity to ground at the loose part of connector X172 at pins 5 and 7 (WP 0048 00-15). There should not be continuity to ground. <li data-bbox="724 693 1096 1039">2. Check for continuity. Disconnect and inspect connector 827 located on the top of the transmission. Check continuity at the mounted part of connector 827 between pin 5 and ground and pin 7 and ground (WP 0048 00-15). There should not be continuity to ground. <li data-bbox="724 1039 1096 1239">3. Inspect the 827 connector and pins for damage and proper connection. Check for continuity to ground for wires 1725 and 1727 (WP 0048 00-15). <li data-bbox="724 1239 1096 1862">4. Check for continuity. Disconnect ECU (793) and connector X172. Check the connector and ECU pins 12, 13, and 9 for damage. Check for continuity to ground for wires A1725, A1727A, and A1727B (WP 0048 00-15). There should not be continuity to ground. 	<p data-bbox="1096 401 1472 693">If continuity to ground is found, move the cab to the transport position (TM 10-3930-675-10) and remove the transmission front access cover (WP 0142 00).</p> <p data-bbox="1096 693 1472 1039">If continuity to ground is found or the 827 connector is damaged, replace the transmission (WP 0224 00).</p> <p data-bbox="1096 1039 1472 1239">If continuity to ground is present in either wire or connector 827 is damaged, replace grounded engine and transmission wiring harness (WP 0113 00).</p> <ol style="list-style-type: none"> <li data-bbox="1096 1239 1472 1312">a. Repair or replace damaged connector (WP 0113 00). <li data-bbox="1096 1312 1472 1375">b. Replace damaged ECU (793) (WP 0079 00). <li data-bbox="1096 1375 1472 1862">c. Replace open or grounded wire.

Table 15. Error Code 734 - Clutch KV Open Circuit Failure Troubleshooting Procedures.

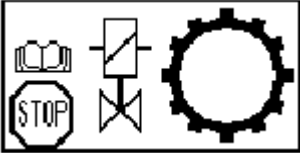
MALFUNCTION	TEST OR INSPECTION	CORRECTIVE ACTION
<p data-bbox="159 409 719 468">Error Code 734 - Clutch KV Open Circuit Failure.</p> 	<ol style="list-style-type: none"> <li data-bbox="732 409 1088 695">1. Check for resistance. Disconnect connector X172 located in the middle panel behind the operator's seat. Check resistance at the loose part of connector X172 between pins 5 and 7 (WP 0048 00-15). Resistance should be 18 to 20 Ohms. <li data-bbox="732 709 1088 995">2. Check for resistance. Disconnect and inspect connector 827 located on the top of the transmission. Check resistance at the mounted part of connector 827 between pins 5 and 7 (WP 0048 00-15). Resistance should be 18 to 20 Ohms. <li data-bbox="732 1010 1088 1171">3. Inspect the 827 connector and pins for damage and proper connection. Check continuity of wires 1725 and 1727 (WP 0048 00-15). <li data-bbox="732 1186 1088 1409">4. Check for continuity. Disconnect ECU (793). Check the connector and ECU pins 12, 13, and 9 for damage. Check continuity of wires A1725, A1727A, and A1727B (WP 0048 00-15). 	<p data-bbox="1101 409 1461 571">If resistance is not as specified, move the cab to the transport position (TM 10-3930-675-10) and remove the transmission front access cover (WP 0142 00).</p> <p data-bbox="1101 709 1461 840">If resistance is not as specified or the 827 connector is damaged, replace the transmission (WP 0224 00).</p> <p data-bbox="1101 1010 1461 1171">If continuity is not present in either wire or connector 827 is damaged, replace engine and transmission wiring harness (WP 0113 00).</p> <ol style="list-style-type: none"> <li data-bbox="1101 1186 1461 1245">a. Repair or replace damaged connector (WP 0113 00). <li data-bbox="1101 1251 1461 1310">b. Replace damaged ECU (793) (WP 0080 00). <li data-bbox="1101 1316 1461 1375">c. Replace open, damaged, or shorted wire.

Table 16. Error Code 735 - Clutch KR Short Circuit to Battery Failure Troubleshooting Procedures.

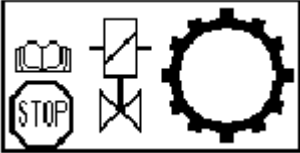
MALFUNCTION	TEST OR INSPECTION	CORRECTIVE ACTION
<p data-bbox="159 407 717 468">Error Code 735 - Clutch KR Short Circuit to Battery Failure.</p> 	<ol style="list-style-type: none"> <li data-bbox="730 407 1089 688">1. Check for resistance. Disconnect connector X172 located in the middle panel behind the operator's seat. Check resistance at the loose part of connector X172 between pins 1 and 7 (WP 0048 00-15). Resistance should be 18 to 20 Ohms. <li data-bbox="730 709 1089 991">2. Check for resistance. Disconnect and inspect connector 827 located on the top of the transmission. Check resistance at the mounted part of connector 827 between pins 1 and 7 (WP 0048 00-15). Resistance should be 18 to 20 Ohms. <li data-bbox="730 1012 1089 1167">3. Inspect the 827 connector and pin for damage and proper connection. Check continuity of wires 1721 and 1727 (WP 0048 00-15). <li data-bbox="730 1188 1089 1436">4. Check for continuity. Ensure connectors X172 and 827 are disconnected. Check continuity between the loose part of X172 pin 1 and each other pin of X172. There should not be continuity between the pins. <li data-bbox="730 1457 1089 1675">5. Check for continuity. Disconnect ECU (793). Check the connector and ECU pins 12, 13, and 10 for damage. Check continuity of wires A1721, A1727A, and A1727B (WP 0048 00-15). 	<p data-bbox="1102 407 1461 562">If resistance is not as specified, move the cab to the transport position (TM 10-3930-675-10) and remove the transmission front access cover (WP 0142 00).</p> <p data-bbox="1102 709 1461 831">If resistance is not as specified or the 827 connector is damaged, replace the transmission (WP 0224 00).</p> <p data-bbox="1102 1012 1461 1167">If continuity is not present in either wire or connector 827 is damaged, replace engine and transmission wiring harness (WP 0113 00).</p> <p data-bbox="1102 1188 1461 1344">If continuity is present in any pin combination continuity check, replace shorted engine and transmission wiring harness (WP 0113 00).</p> <ol style="list-style-type: none"> <li data-bbox="1102 1457 1461 1518">a. Repair or replace damaged connector (WP 0113 00). <li data-bbox="1102 1518 1461 1579">b. Replace damaged ECU (793) (WP 0080 00). <li data-bbox="1102 1579 1461 1612">c. Replace open or shorted wire.

Table 17. Error Code 736 - Clutch KR Short Circuit to Chassis Failure Troubleshooting Procedures.

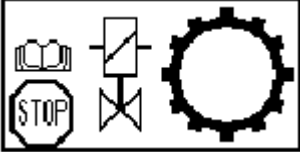
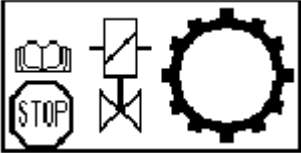
MALFUNCTION	TEST OR INSPECTION	CORRECTIVE ACTION
<p data-bbox="159 407 717 468">Error Code 736 - Clutch KR Short Circuit to Chassis Failure.</p> 	<ol style="list-style-type: none"> <li data-bbox="730 407 1089 695">1. Check for continuity. Disconnect connector X172 located in the middle panel behind the operator's seat. Check for continuity to ground at the loose part of connector X172 at pins 1 and 7 (WP 0048 00-15). There should not be continuity to ground. <li data-bbox="730 709 1089 1031">2. Check for continuity. Disconnect and inspect connector 827 located on the top of the transmission. Check continuity at the mounted part of connector 827 between pin 1 and ground and pin 7 and ground (WP 0048 00-15). There should not be continuity to ground. <li data-bbox="730 1045 1089 1234">3. Inspect the 827 connector and pins for damage and proper connection. Check for continuity to ground for wires 1721 and 1727 (WP 0048 00-15). <li data-bbox="730 1249 1089 1570">4. Check for continuity. Disconnect ECU (793) and connector X172. Check the connector and ECU pins 12, 13, and 10 for damage. Check for continuity to ground for wires A1721, A1727A, and A1727B (WP 0048 00-15). There should not be continuity to ground. 	<p data-bbox="1102 407 1461 569">If continuity to ground is found, move the cab to the transport position (TM 10-3930-675-10) and remove the transmission front access cover (WP 0142 00).</p> <p data-bbox="1102 709 1461 835">If continuity to ground is found or the 827 connector is damaged, replace the transmission (WP 0224 00).</p> <p data-bbox="1102 1045 1461 1199">If continuity to ground is present in either wire or connector 827 is damaged, replace grounded engine and transmission wiring harness (WP 0113 00).</p> <ol style="list-style-type: none"> <li data-bbox="1102 1249 1461 1312">a. Repair or replace damaged connector (WP 0113 00). <li data-bbox="1102 1312 1461 1375">b. Replace damaged ECU (793) (WP 0080 00). <li data-bbox="1102 1375 1461 1438">c. Replace open or grounded wire.

Table 18. Error Code 737 - Clutch KR Open Circuit Failure Troubleshooting Procedures.

MALFUNCTION	TEST OR INSPECTION	CORRECTIVE ACTION
<p data-bbox="159 409 722 472">Error Code 737 - Clutch KR Open Circuit Failure.</p> 	<ol style="list-style-type: none"> <li data-bbox="732 409 1092 693">1. Check for resistance. Disconnect connector X172 located in the middle panel behind the operator's seat. Check resistance at the loose part of connector X172 between pins 1 and 7 (WP 0048 00-15). Resistance should be 18 to 20 Ohms. <li data-bbox="732 709 1092 993">2. Check for resistance. Disconnect and inspect connector 827 located on the top of the transmission. Check resistance at the mounted part of connector 827 between pins 1 and 7 (WP 0048 00-15). Resistance should be 18 to 20 Ohms. <li data-bbox="732 1010 1092 1167">3. Inspect the 827 connector and pins for damage and proper connection. Check continuity of wires 1721 and 1727 (WP 0048 00-15). <li data-bbox="732 1184 1092 1404">4. Check for continuity. Disconnect ECU (793). Check the connector and ECU pins 12, 13, and 10 for damage. Check continuity of wires A1721, A1727A, and A1727B (WP 0048 00-15). 	<p data-bbox="1102 409 1461 567">If resistance is not as specified, move the cab to the transport position (TM 10-3930-675-10) and remove the transmission front access cover (WP 0142 00).</p> <p data-bbox="1102 709 1461 835">If resistance is not as specified or the 827 connector is damaged, replace the transmission (WP 0224 00).</p> <p data-bbox="1102 1010 1461 1167">If continuity is not present in either wire or connector 827 is damaged, replace engine and transmission wiring harness (WP 0113 00).</p> <ol style="list-style-type: none"> <li data-bbox="1102 1184 1461 1247">a. Repair or replace damaged connector (WP 0113 00). <li data-bbox="1102 1247 1461 1310">b. Replace damaged ECU (793) (WP 0080 00). <li data-bbox="1102 1310 1461 1373">c. Replace open, damaged, or shorted wire.

END OF WORK PACKAGE

MISCELLANEOUS TRANSMISSION FAILURE TROUBLESHOOTING

0029 00

THIS WORK PACKAGE COVERS

- Error Code 618 - Signal from Gear Selector Not Correct
- Error Code 622 - Feedback Signal from 2WD/4WD Switch Not Correct
- Error Code 745 - Backup Alarm Control Circuit, Short Circuit to Chassis Failure
- Error Code 746 - Backup Alarm Control Circuit, Short Circuit to Battery Failure

- Error Code 747 - Backup Alarm Control Circuit, Open Circuit Failure
- Error Code 761 - 2WD/4WD Connection Valve Circuit, Short Circuit to Chassis Failure
- Error Code 762 - 2WD/4WD Connection Valve Circuit, Short Circuit to Battery Failure
- Error Code 763 - 2WD/4WD Connection Valve Circuit, Open Circuit Failure

INITIAL SETUP

References

- TM 10-3930-675-10
- ECU Transmission (A34650.0200) (WP 0048 00-12)
- Shifting (A34739.0200) (WP 0048 00-35)

References - Continued

- ECS Electrical Servo (A34648.0200) (WP 0048 00-5)
- Lights (A34744.0200) (WP 0048 00-41)

NOTE

Refer to WP 0004 00 for additional troubleshooting guidance, information, and illustrations that locate critical components.

Table 1. Error Code 618 - Signal from Gear Selector Not Correct Troubleshooting Procedures.


MALFUNCTION	TEST OR INSPECTION	CORRECTIVE ACTION
<p data-bbox="159 1213 717 1270">Error Code 618 - Signal from Gear Selector Not Correct.</p> 	<ol style="list-style-type: none"> <li data-bbox="734 1213 1091 1339">1. Check position signals. Enter DIAG GEARBOX 2(12) in the diagnostic menu and check the shift lever position signals. <li data-bbox="734 1360 1091 1516">2. Check connection to cab distribution box behind the left rear panel of the cab. Disconnect X28 from the back of the cab distribution box. 	<p data-bbox="1107 1213 1450 1270">If signals from shift lever are not correct, continue with next steps.</p>

Table 1. Error Code 618 - Signal from Gear Selector Not Correct Troubleshooting Procedures - Continued.

MALFUNCTION	TEST OR INSPECTION	CORRECTIVE ACTION
<p>Error Code 618 - Signal from Gear Selector Not Correct - Continued.</p>	<p>3. Check continuity. On the loose end of X28 check continuity between specified pins and continuity of each pin to ground (WP 0048 00-15).</p> <p>a. With the shift lever in neutral, check continuity between X28 pin 9 and X28 pin 7.</p> <p>b. With the shift lever in forward, check continuity between X28 pin 9 and X28 pin 8.</p> <p>c. With the shift lever in reverse, check continuity between X28 pin 9 and X28 pin 6.</p> <p>4. Check voltage. Reconnect X28 and check voltage (24V) at X28 pin 9 with the ignition ON (WP 0048 00-135).</p> <p>5. Check for voltage (24V) at the following pins with the ignition on (WP 0048 00-35):</p> <p>a. With the shift lever in neutral, check continuity of X174 pin 7.</p> <p>b. With the shift lever is forward, check continuity of X174 pin 6.</p> <p>c. With the shift lever in reverse, X174 check continuity of pin 8.</p> <p>6. Inspect connector X174 pins 6, 7, and 8 for connection or damage (WP 0048 00-13).</p> <p>7. Check continuity. Disconnect ECU (793). Check the connector and ECU pins 43, 64, and 67 for damage. Check continuity of wires A1746, A1747, and A1748 (WP 0048 00-13).</p>	<p>a. There should be continuity between each specified pin and shift lever combination and no continuity to ground.</p> <p>b. If continuity is not found on any of the checks, gain access to XS1 by removing the kick panels in front of the steering column. Make the same continuity checks on connector XS1 using the same pin numbering and shifter lever positions (WP 0048 00-35).</p> <p>c. If continuity checks are not as specified, replace shift lever (WP 0113 00).</p> <p>a. If no voltage (24V) is found, check continuity of wires A284, A284A, and 289 (WP 0048 00-35).</p> <p>b. Repair or replace damaged connectors (WP 0113 00).</p> <p>c. Replace open or shorted wire.</p> <p>a. If no voltage (24V) is found at any one pin, check continuity of wires 288, 287, 286, A288, A287, A286, 461, 462, and 463 (WP 0048 00-35).</p> <p>b. Repair or replace damaged connector (WP 0113 00).</p> <p>c. Replace open or shorted wire or harness (WP 0113 00).</p> <p>Repair or replace damaged connector (WP 0113 00).</p> <p>a. Repair or replace damaged connector (WP 0113 00).</p> <p>b. Replace damaged ECU (793) (WP 0080 00).</p> <p>c. Replace open or shorted wire.</p>

Table 2. Error Code 622 - Feedback Signal from 2WD/4WD Switch Not Correct Troubleshooting Procedures.


MALFUNCTION	TEST OR INSPECTION	CORRECTIVE ACTION
<p data-bbox="159 443 722 499">Error Code 622 - Feedback Signal from 2WD/4WD Switch Not Correct.</p> 	<ol style="list-style-type: none"> <li data-bbox="732 443 1092 632">1. Check for proper signals. Enter DIAG GEARBOX 8(12) in the diagnostic menu and check the drive position signals while switching between 2WD and 4WD steering modes. <li data-bbox="732 646 1092 709">2. Ensure circuit breaker F28 is not tripped. <li data-bbox="732 724 1092 947">3. Check for voltage. Access middle panel behind seat and disconnect X173. Turn the ignition on and check voltage (24V) on the mounted part of X173 pin 3 and pin 10 to ground. <li data-bbox="732 1024 1092 1310">4. Check voltage (24V) at X173 pin 11 (WP 0048 00-14) with the engine running and switching back and forth between 2WD and 4WD steering modes. Voltage (24V) should be present while in 2WD and no voltage while in 4WD steering mode. <li data-bbox="732 1556 1092 1709">5. Check the connector and ECU pin 29 for damage. Disconnect ECU (793). Check continuity of wire A17311 (WP 0048 00-14). 	<p data-bbox="1102 443 1459 499">If signals do not change, continue with next steps.</p> <p data-bbox="1102 646 1333 674">Reset circuit breaker.</p> <ol style="list-style-type: none"> <li data-bbox="1102 724 1459 913">a. If no voltage (24V) is found, check continuity of wires A472, 472 (WP 0048 00-32), A1724B (WP 0048 00-12), and A1742C (WP 0048 00-14). <li data-bbox="1102 919 1459 976">b. Repair or replace damaged connector (WP 0113 00). <li data-bbox="1102 982 1459 1010">c. Replace open or shorted wire. <p data-bbox="1102 1031 1459 1058">If voltage checks are not correct:</p> <ol style="list-style-type: none"> <li data-bbox="1102 1064 1459 1274">a. Locate the 7207 sensor at the bottom of the transmission. Check the connector for proper connection to 7207 sensor. Check continuity of wires 17310 and 17311 (WP 0048 00-14). <li data-bbox="1102 1281 1459 1434">b. If wires 17310 and 17311 are open or shorted, notify sustainment maintenance to replace engine and transmission wiring harness. <li data-bbox="1102 1440 1459 1530">c. If connection and wire continuity is correct, replace 7207 sensor (WP 0095 00). <ol style="list-style-type: none"> <li data-bbox="1102 1556 1459 1612">a. Repair or replace damaged connector (WP 0113 00). <li data-bbox="1102 1619 1459 1675">b. Replace damaged ECU (793) (WP 0080 00). <li data-bbox="1102 1682 1459 1709">c. Replace open or shorted wire.

Table 3. Error Code 745 - Backup Alarm Control Circuit, Short Circuit to Chassis Failure Troubleshooting Procedures.


MALFUNCTION	TEST OR INSPECTION	CORRECTIVE ACTION
<p data-bbox="159 443 719 499">Error Code 745 - Backup Alarm Control Circuit, Short Circuit to Chassis Failure.</p> 	<p data-bbox="732 443 1089 499">1. Ensure circuit breaker F10 is not tripped.</p> <p data-bbox="1045 520 1146 552" style="text-align: center;">NOTE</p> <p data-bbox="781 569 1414 625" style="text-align: center;">This error code may be active if the backup alarm/ lights remain on.</p> <p data-bbox="732 646 1089 926">2. Check for error code displayed. Access the middle panel behind operator's seat and disconnect X177. Turn the ignition on and check for error code 745. (There may be several error codes that display when connector X177 is disconnected).</p> <p data-bbox="732 947 1089 1226">3. Check for continuity. Access relay 305 in the cab distribution box. Remove the 305 relay and disconnect connector X177. Check for continuity to ground for wires 16010 (WP 0048 00-12), A1507 (WP 0048 00-17), 293, and A55 (WP 0048 00-45).</p>	<p data-bbox="1105 443 1333 474">Reset circuit breaker.</p> <p data-bbox="1105 646 1464 926">a. If error code 745 is no longer active, continue with step 3. b. If error code 745 is still active, check for continuity to ground for wire A17710 (WP 0048 00-12). c. If wire A17710 is not grounded, replace ECU (793) (WP 0080 00).</p> <p data-bbox="1105 947 1464 1041">a. Repair or replace damaged connector (WP 0113 00). b. Replace grounded wire.</p>

Table 4. Error Code 746 - Backup Alarm Control Circuit, Short Circuit to Battery Failure Troubleshooting Procedures.


MALFUNCTION	TEST OR INSPECTION	CORRECTIVE ACTION
<p>Error Code 746 - Backup Alarm Control Circuit, Short Circuit to Battery Failure.</p> 	<ol style="list-style-type: none"> 1. Ensure circuit breaker F10 is not tripped. 2. Check for error code displayed. Access the middle panel behind operator's seat and disconnect X177. Turn the ignition on and check for error code 746 (there may be several error codes that display when connector X177 is disconnected). 	<p>Reset circuit breaker.</p> <ol style="list-style-type: none"> a. If error code 746 is no longer active, access relay 305 in the cab distribution box. Remove the 305 relay and test the resistance between pins 85 and 86. Resistance should be 290 to 350 Ohms. b. Replace relay if resistance is not as specified (WP 0074 00). c. If error code 746 is still active, replace ECU (793) (WP 0080 00).

Table 5. Error Code 747 - Backup Alarm Control Circuit, Open Circuit Failure Troubleshooting Procedures.


MALFUNCTION	TEST OR INSPECTION	CORRECTIVE ACTION
<p>Error Code 747 - Backup Alarm Control Circuit, Open Circuit Failure.</p> 	<ol style="list-style-type: none"> 1. Ensure circuit breaker F10 is not tripped. 2. Check for resistance. Access relay 305 in the cab distribution box. Remove the 305 relay and check resistance between pins 85 and 86. Resistance should be 290 to 350 Ohms. 3. Check for voltage. With the 305 relay still removed, check voltage (24V) at relay socket pin 86 with the ignition on. 	<p>Reset circuit breaker.</p> <p>Replace relay if resistance is not as specified (WP 0074 00).</p> <ol style="list-style-type: none"> a. If no voltage (24V) is found, check circuit breaker F10 and continuity of wires A57 and A57A (WP 0048 00-45). b. Replace damaged or non-operational circuit breaker (WP 0074 00). c. Repair or replace damaged connector (WP 0113 00). d. Replace damaged or open wire.

Table 5. Error Code 747 - Backup Alarm Control Circuit, Open Circuit Failure Troubleshooting Procedures - Continued.

MALFUNCTION	TEST OR INSPECTION	CORRECTIVE ACTION
<p>Error Code 747 - Backup Alarm Control Circuit, Open Circuit Failure - Continued.</p>	<p>4. Check for continuity. With the 305 relay still removed, check continuity between the 305 relay socket pin 86 and connector XK5 pin 2 and 305 relay socket pin 85 and connector XK5 pin 5.</p> <p>5. Inspect connectors X29, X160, and X177 for damage and connection. Check continuity of wires A55, 293 (WP 0048 00-45), 16010, and A17710 (WP 0048 00-12).</p>	<p>a. If no continuity is found at either check, remove the relay board and check the underside for damage.</p> <p>b. Replace damaged relay board (WP 0074 00).</p> <p>a. Repair or replace damaged connector (WP 0113 00).</p> <p>b. Replace damaged or open wire.</p>

Table 6. Error Code 761 - 2WD/4WD Connection Valve Circuit, Short Circuit to Chassis Failure Troubleshooting Procedures.

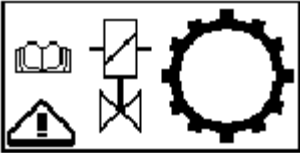
MALFUNCTION	TEST OR INSPECTION	CORRECTIVE ACTION
<p>Error Code 761 - 2WD/4WD Connection Valve Circuit, Short Circuit to Chassis Failure.</p> 	<p>1. Check for continuity. Disconnect connector X172 located in the middle panel behind the operator's seat. Check for continuity to ground at the loose part of connector X172 at pins 14 and 15 (WP 0048 00-15). There should not be continuity to ground.</p> <p>2. Check for continuity. Disconnect and inspect connector 606. Check continuity at the 606 solenoid between each pin and ground (WP 0048 00-15). There should not be continuity to ground.</p> <p>3. Inspect the 606 connector and pins for damaged and proper connection. Check for continuity to ground for wires 17214 and 17215 (WP 0048 00-15).</p>	<p>a. If continuity to ground is found, locate the AWD/4WD connection valve at the left rear of the transmission. Inspect the solenoid (606) and connector for damage.</p> <p>b. Replace damaged 606 solenoid (WP 0171 00).</p> <p>a. If continuity to ground, replace grounded 606 solenoid (WP 0171 00).</p> <p>b. If the 606 connector is damaged, notify Sustainment Maintenance to replace engine and transmission wiring harness.</p> <p>If continuity to ground is present in either wire or connector 606 is damaged, notify Sustainment Maintenance to replace engine and transmission wiring harness.</p>

Table 6. Error Code 761 - 2WD/4WD Connection Valve Circuit, Short Circuit to Chassis Failure Troubleshooting Procedures - Continued.

MALFUNCTION	TEST OR INSPECTION	CORRECTIVE ACTION
Error Code 761 - 2WD/4WD Connection Valve Circuit, Short Circuit to Chassis Failure - Continued.	4. Check connector, pins, and wires. Disconnect ECU (793) and connector X172. Check the connector and ECU pins 11 and 53 for damage. Check for continuity to ground for wires A17214 and A17215 (WP 0048 00-15). There should not be continuity to ground.	a. Repair or replace damaged connector (WP 0113 00). b. Replace damaged ECU (793) (WP 0080 00). c. Replace open or grounded wire.

Table 7. Error Code 762 - 2WD/4WD Connection Valve Circuit, Short Circuit to Battery Failure Troubleshooting Procedures.

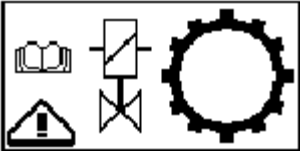
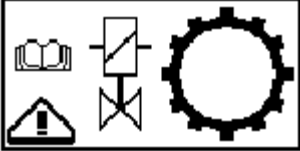
MALFUNCTION	TEST OR INSPECTION	CORRECTIVE ACTION
Error Code 762 - 2WD/4WD Connection Valve Circuit, Short Circuit to Battery Failure. 	<p>1. Check for resistance. Disconnect connector X172 located in the middle panel behind the operator's seat. Check for resistance at the loose part of connector X172 at pins 14 and 15 (WP 0048 00-15). Resistance should be 30 to 40 Ohms.</p> <p>2. Check for resistance. Disconnect and inspect connector 606. Check resistance of the 606 solenoid between each pin of the solenoid (WP 0048 00-15). Resistance should be 30 to 40 Ohms.</p> <p>3. Check for continuity. Disconnect the 606 connector and connector X172. Check for continuity on the loose part of X172 pin 14 and all of the other pins of the connector. Do the same check for pin 15 (WP 0048 00-15). There should not be continuity between the pins.</p>	<p>a. If resistance is not as specified, locate the 2WD/4WD connection valve at the left rear of the transmission. Inspect the solenoid (606) and connector for damage.</p> <p>b. Replace damaged 606 solenoid (WP 0171 00).</p> <p>a. If resistance is not as specified, replace 606 solenoid (WP 0171 00).</p> <p>b. If the 606 connector is damaged, notify Sustainment Maintenance to replace engine and transmission wiring harness.</p> <p>If continuity is present between pins, notify Sustainment Maintenance to replace engine and transmission wiring harness.</p>

Table 7. Error Code 762 - 2WD/4WD Connection Valve Circuit, Short Circuit to Battery Failure Troubleshooting Procedures - Continued.

MALFUNCTION	TEST OR INSPECTION	CORRECTIVE ACTION
Error Code 762 - 2WD/4WD Connection Valve Circuit, Short Circuit to Battery Failure - Continued.	4. Check for continuity. Disconnect ECU (793) and connector X172. Check the connector and ECU pins 11 and 53 for damage. Check for continuity of wires A17214 and A17215 (WP 0048 00-15).	a. Repair or replace damaged connector (WP 0113 00). b. Replace damaged ECU (793) (WP 0080 00). c. Replace open or grounded wire.

Table 8. Error Code 763 - 2WD/4WD Connection Valve Circuit, Open Circuit Failure Troubleshooting Procedures.

MALFUNCTION	TEST OR INSPECTION	CORRECTIVE ACTION
<p>Error Code 763 - 2WD/4WD Connection Valve Circuit, Open Circuit Failure.</p> 	<p>1. Check for resistance. Disconnect connector X172 located in the middle panel behind the operator's seat. Check for resistance at the loose part of connector X172 at pins 14 and 15 (WP 0048 00-15). Resistance should be 30 to 40 Ohms.</p> <p>2. Check for resistance. Disconnect and inspect connector 606. Check resistance of the 606 solenoid between each pin of the solenoid (WP 0048 00-15). Resistance should be 30 to 40 Ohms.</p> <p>3. Inspect the 606 connector and pins for damage and proper connection. Check continuity of wires 17214 and 17215 (WP 0048 00-15).</p> <p>4. Check for continuity. Disconnect ECU (793) and connector X172. Check the connector and ECU pins 11 and 53 for damage. Check continuity of wires A17214 and A17215 (WP 0048 00-15).</p>	<p>a. If resistance is not as specified, locate the 2WD/4WD connection valve at the left rear of the transmission. Inspect the solenoid (606) and connector for damage.</p> <p>b. Replace damaged 606 solenoid (WP 0171 00).</p> <p>a. If resistance is not as specified, replace 606 solenoid (WP 0171 00).</p> <p>b. If the 606 connector is damaged, notify Sustainment Maintenance to replace engine and transmission wiring harness.</p> <p>If continuity is not present in either wire, notify Sustainment Maintenance to replace engine and transmission wiring harness.</p> <p>a. Repair or replace damaged connector (WP 0113 00). b. Replace damaged ECU (793) (WP 0080 00). c. Replace open wire.</p>

END OF WORK PACKAGE

INTERNAL TRANSMISSION CLUTCH SLIPPAGE FAILURE TROUBLESHOOTING

0030 00

THIS WORK PACKAGE COVERS

Error Code 777 - Internal Transmission Failure at Clutch K1

Error Code 778 - Internal Transmission Failure at Clutch K2

Error Code 779 - Internal Transmission Failure at Clutch K3

Error Code 780 - Internal Transmission Failure at Clutch K4

Error Code 781 - Internal Transmission Failure at Clutch KV

Error Code 782 - Internal Transmission Failure at Clutch KR

Error Code 845 - Clutch Failure Detected During Calibration

Error Code 846 - Clutch Adjustment Data Lost

INITIAL SETUP

References

TM 10-3930-675-10

ECU Transmission (A34648.0200) (WP 0048 00-12)

NOTE

Refer to WP 0004 00 for additional troubleshooting guidance, information, and illustrations that locate critical components.

Table 1. Error Code 777 - Internal Transmission Failure at Clutch K1 Troubleshooting Procedures.


MALFUNCTION	TEST OR INSPECTION	CORRECTIVE ACTION
<p>Error Code 777 - Internal Transmission Failure at Clutch K1.</p> 	<ol style="list-style-type: none"> 1. Check transmission oil level. 2. Inspect all electrical connections on the transmission for loose or unplugged connectors. 3. Perform troubleshooting procedure for error codes 655, 656, 658, and 659. 	<ol style="list-style-type: none"> a. Consult the Lubrication Instructions for the proper oil type and filling procedure (WP 0050 00 or TM 10-3930-675-10-1). b. Fill transmission to proper oil level. a. Connect disconnected electrical connectors. b. Notify Sustainment Maintenance to replace engine and transmission wiring harness. a. Correct any problems found during the error code troubleshooting procedures. b. Replace transmission assembly (WP 0224 00).

Table 2. Error Code 778 - Internal Transmission Failure at Clutch K2 Troubleshooting Procedures.


MALFUNCTION	TEST OR INSPECTION	CORRECTIVE ACTION
<p data-bbox="159 401 719 457">Error Code 778 - Internal Transmission Failure at Clutch K2.</p> 	<ol style="list-style-type: none"> <li data-bbox="732 401 1089 428">1. Check transmission oil level. <li data-bbox="732 642 1089 762">2. Inspect all electrical connections on the transmission for loose or unplugged connectors. <li data-bbox="732 848 1089 936">3. Perform troubleshooting procedure for error codes 655, 656, 658, and 659. 	<ol style="list-style-type: none"> <li data-bbox="1105 401 1466 554">a. Consult the Lubrication Instructions for the proper oil type and filling procedure (WP 0050 00 or TM 10-3930-675-10-1). <li data-bbox="1105 562 1466 619">b. Fill transmission to proper oil level. <li data-bbox="1105 642 1466 699">a. Connect disconnected electrical connectors. <li data-bbox="1105 707 1466 827">b. Notify Sustainment Maintenance to replace engine and transmission wiring harness. <li data-bbox="1105 848 1466 936">a. Correct any problems found during the error code troubleshooting procedures. <li data-bbox="1105 945 1466 1001">b. Replace transmission assembly (WP 0224 00).

Table 3. Error Code 779 - Internal Transmission Failure at Clutch K3 Troubleshooting Procedures.


MALFUNCTION	TEST OR INSPECTION	CORRECTIVE ACTION
<p data-bbox="159 1176 719 1232">Error Code 779 - Internal Transmission Failure at Clutch K3.</p> 	<ol style="list-style-type: none"> <li data-bbox="732 1176 1089 1203">1. Check transmission oil level. <li data-bbox="732 1417 1089 1537">2. Inspect all electrical connections on the transmission for loose or unplugged connectors. <li data-bbox="732 1623 1089 1711">3. Perform troubleshooting procedure for error codes 655, 656, 658, and 659. 	<ol style="list-style-type: none"> <li data-bbox="1105 1176 1466 1329">a. Consult the Lubrication Instructions for the proper oil type and filling procedure (WP 0050 00 or TM 10-3930-675-10-1). <li data-bbox="1105 1337 1466 1394">b. Fill transmission to proper oil level. <li data-bbox="1105 1417 1466 1474">a. Connect disconnected electrical connectors. <li data-bbox="1105 1482 1466 1602">b. Notify Sustainment Maintenance to replace engine and transmission wiring harness. <li data-bbox="1105 1623 1466 1711">a. Correct any problems found during the error code troubleshooting procedures. <li data-bbox="1105 1719 1466 1776">b. Replace transmission assembly (WP 0224 00).

Table 4. Error Code 780 - Internal Transmission Failure at Clutch K4 Troubleshooting Procedures.


MALFUNCTION	TEST OR INSPECTION	CORRECTIVE ACTION
<p data-bbox="159 407 717 466">Error Code 780 - Internal Transmission Failure at Clutch K4.</p> 	<ol style="list-style-type: none"> <li data-bbox="730 407 1091 436">1. Check transmission oil level. <li data-bbox="730 667 1091 793">2. Inspect all electrical connections on the transmission for loose or unplugged connectors. <li data-bbox="730 877 1091 961">3. Perform troubleshooting procedure for error codes 655, 656, 658, and 659. 	<ol style="list-style-type: none"> <li data-bbox="1104 407 1464 562">a. Consult the Lubrication Instructions for the proper oil type and filling procedure (WP 0050 00 or TM 10-3930-675-10-1). <li data-bbox="1104 571 1464 625">b. Fill transmission to proper oil level. <li data-bbox="1104 667 1464 722">a. Connect disconnected electrical connectors. <li data-bbox="1104 730 1464 856">b. Notify Sustainment Maintenance to replace engine and transmission wiring harness. <li data-bbox="1104 877 1464 966">a. Correct any problems found during the error code troubleshooting procedures. <li data-bbox="1104 974 1464 1029">b. Replace transmission assembly (WP 0224 00).

Table 5. Error Code 781 - Internal Transmission Failure at Clutch KV Troubleshooting Procedures.


MALFUNCTION	TEST OR INSPECTION	CORRECTIVE ACTION
<p data-bbox="159 1194 717 1253">Error Code 781 - Internal Transmission Failure at Clutch KV.</p> 	<ol style="list-style-type: none"> <li data-bbox="730 1194 1091 1224">1. Check transmission oil level. <li data-bbox="730 1455 1091 1581">2. Inspect all electrical connections on the transmission for loose or unplugged connectors. <li data-bbox="730 1665 1091 1749">3. Perform troubleshooting procedure for error codes 655, 656, 658, and 659. 	<ol style="list-style-type: none"> <li data-bbox="1104 1194 1464 1350">a. Consult the Lubrication Instructions for the proper oil type and filling procedure (WP 0050 00 or TM 10-3930-675-10-1). <li data-bbox="1104 1358 1464 1413">b. Fill transmission to proper oil level. <li data-bbox="1104 1455 1464 1509">a. Connect disconnected electrical connectors. <li data-bbox="1104 1518 1464 1644">b. Notify Sustainment Maintenance to replace engine and transmission wiring harness. <li data-bbox="1104 1665 1464 1753">a. Correct any problems found during the error code troubleshooting procedures. <li data-bbox="1104 1761 1464 1816">b. Replace transmission assembly (WP 0224 00).

Table 6. Error Code 782 - Internal Transmission Failure at Clutch KR Troubleshooting Procedures.


MALFUNCTION	TEST OR INSPECTION	CORRECTIVE ACTION
<p>Error Code 782 - Internal Transmission Failure at Clutch KR.</p> 	<ol style="list-style-type: none"> 1. Check transmission oil level. 2. Inspect all electrical connections on the transmission for loose or unplugged connectors. 3. Perform troubleshooting procedure for error codes 655, 656, 658, and 659. 	<ol style="list-style-type: none"> a. Consult the Lubrication Instructions for the proper oil type and filling procedure (WP 0050 00 or TM 10-3930-675-10-1). b. Fill transmission to proper oil level. a. Connect disconnected electrical connectors. b. Notify Sustainment Maintenance to replace engine and transmission wiring harness. a. Correct any problems found during the error code troubleshooting procedures. b. Replace transmission assembly (WP 0224 00).

Table 7. Error Code 845 - Clutch Failure Detected During Calibration Troubleshooting Procedures.



MALFUNCTION	TEST OR INSPECTION	CORRECTIVE ACTION
<p>Error Code 845 - Clutch Failure Detected During Calibration.</p> 	<p align="center">NOTE</p> <p align="center">ECU (793) will indicate which clutch is affected on the display with this error code.</p> <p>Perform transmission calibration several times to see if the calibration process will complete (WP 0225 00).</p>	<p>If calibration procedure continues to trip error code 845, replace the transmission (WP 0224 00).</p>

Table 8. Error Code 846 - Clutch Adjustment Data Lost Troubleshooting Procedures.

MALFUNCTION	TEST OR INSPECTION	CORRECTIVE ACTION
<p>Error Code 846 - Clutch Adjustment Data Lost.</p> 	<p align="center">NOTE</p> <p align="center">ECU (793) is not able to read the correct clutch adjustment parameters due to a replacement of ECU (793) or a problem during the last data saved.</p> <p>Perform transmission calibration (WP 0225 00).</p>	

END OF WORK PACKAGE

BRAKE SYSTEM TROUBLESHOOTING

0031 00

THIS WORK PACKAGE COVERS

Error Code 118 - Brake System Pressure, Circuit 1 and Circuit 2 Failure

Error Code 120 - Brake System Pressure, Circuit 2 Failure

Error Code 119 - Brake System Pressure, Circuit 1 Failure

INITIAL SETUP

References

TM 10-3930-675-10

Current Supply (A34738.0200) (WP 0048 00-31)

References - Continued


Sender (A34740.0200) (WP 0048 00-36)

Brake System (WP 0048 00-51)

NOTE

- Refer to WP 0004 00 for additional troubleshooting guidance, information, and illustrations that locate critical components.
- Refer also to illustration at end of work package for component location.

Table 1. Error Code 118 - Brake System Pressure, Circuit 1 and Circuit 2 Failure Troubleshooting Procedures.

MALFUNCTION	TEST OR INSPECTION	CORRECTIVE ACTION
<p>Error Code 118 - Brake System Pressure, Circuit 1 and Circuit 2 Failure.</p> 	<ol style="list-style-type: none"> 1. Check if accumulator evacuation valves are open (WP 0164 00). 2. Start engine and allow brake pressure to build up. Press on the service brake pedal several times to check for pressure. 3. Enter "EXTRA FUNC" 7(13) in the diagnostic menu and check status of both brake circuits. 4. Check circuit breaker F3 for trip. 5. Start engine and allow brake pressure to built up. Check voltage (24V) at X150 pins 9 and 10 (WP 0048 00-7). 	<p>Close accumulator evacuation valves.</p> <p>If no pressure felt on service brake pedal, perform brake pressure tests (WP 0188 00) and troubleshooting (WP 0005 00).</p> <p>A "0" at either brake circuit would indicate an open pressure switch due to low brake pressure, faulty pressure switch or open circuit.</p> <p>Reset circuit breaker as required.</p> <p>a. If no voltage (24V) is found, proceed with step 6.</p>

**Table 1. Error Code 118 - Brake System Pressure, Circuit 1 and Circuit 2 Failure
Troubleshooting Procedures - Continued.**

MALFUNCTION	TEST OR INSPECTION	CORRECTIVE ACTION
<p>Error Code 118 - Brake System Pressure, Circuit 1 and Circuit 2 Failure - Continued.</p>	<p>6. Check voltage (24V) at X18 pin 1 (WP 0048 00-36).</p> <p>7. Check voltage (24V) at X18 pins 2 and 3 (WP 0048 00-36).</p> <p>8. Check continuity of wires 181, 182, 183, A182, A183, 295, 296, A1509, and A15010 (WP 0048 00-7 and WP 0048 00-36).</p>	<p>b. If voltage (24V) is present, disconnect ECU (790) connector 1 and inspect pins 40 and 41 for damage (WP 0048 00-7).</p> <p>a. If no voltage (24V) is found, check circuit breaker F3 and continuity of wires A266 and A181.</p> <p>b. Repair or replace damaged wires or connectors (WP 0113 00).</p> <p>c. Replace damaged or faulty circuit breaker (WP 0074 00).</p> <p>a. If no voltage (24V) is found at either pin, remove panel in front of the brake pedals and check connections at the brake pressure switches 204-1 and 204-2 (WP 0098 00).</p> <p>b. With the brake pressure built up, check continuity of pressure switches 204-1 and 204-2 (WP 0113 00).</p> <p>c. Replace faulty pressure switch (WP 0098 00).</p> <p>Repair or replace damaged wires or connectors (WP 0113 00).</p>

Table 2. Error Code 119 - Brake System Pressure, Circuit 1 Failure Troubleshooting Procedures.

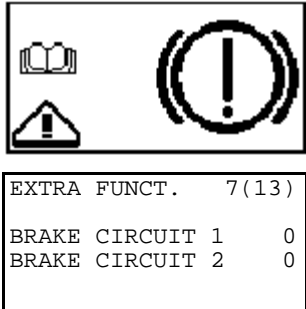
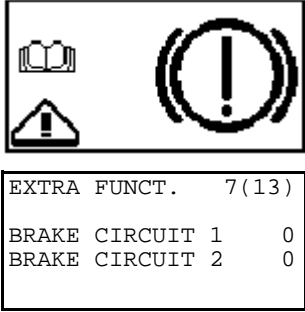
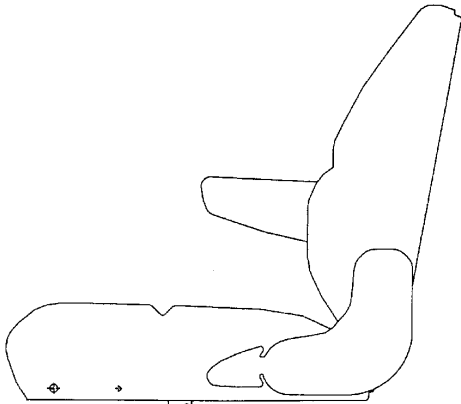
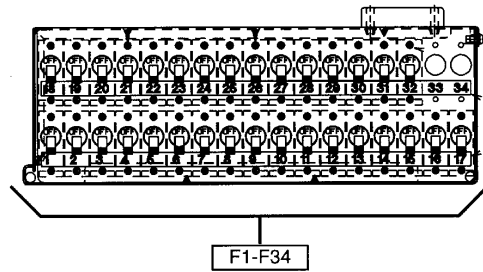
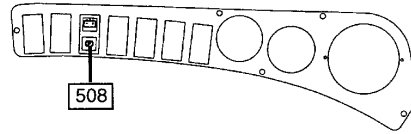
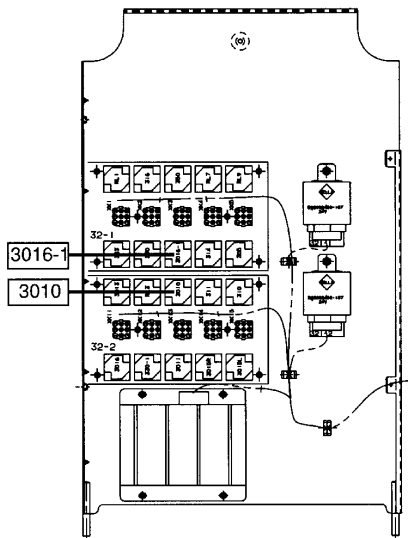
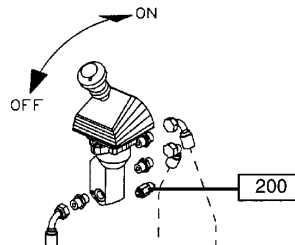
MALFUNCTION	TEST OR INSPECTION	CORRECTIVE ACTION
<p>Error Code 119 - Brake System Pressure, Circuit 1 Failure.</p> 	<ol style="list-style-type: none"> 1. Check if accumulator evacuation valves are open (WP 0164 00). 2. Check brake system pressures at test points 1 and 2 (WP 0187 00). 3. Enter "EXTRA FUNC" 7(13) in the diagnostic menu and check status of both brake circuits. 4. Check circuit breaker F3 for trip. 5. Start engine and allow brake pressure to build up. Check voltage (24V) at X150 pin 9 (WP 0048 00-7). 6. Check voltage (24V) at X18 pin 1 (WP 0048 00-36). 7. Check voltage (24V) at X18 pin 2 (WP 0048 00-36). 8. Check continuity of wires 181, 182, A182, 295, and A1509 (WP 0048 00-7 and WP 0048 00-36). 	<p>Close accumulator evacuation valves.</p> <p>If pressure not as specified, perform brake system troubleshooting (WP 0005 00).</p> <p>A "0" at either brake circuit would indicate an open pressure switch due to low brake pressure, faulty pressure switch or open circuit.</p> <p>Reset circuit breaker as required.</p> <ol style="list-style-type: none"> a. If no voltage (24V) is found, proceed with step 6. b. If voltage (24V) is present, disconnect ECU (790) connector 1 and inspect pin 40 for damage (WP 0048 00-7). <ol style="list-style-type: none"> a. If no voltage (24V) is found, check circuit breaker F3 and continuity of wires A266 and A181. b. Repair or replace damaged wires or connectors (WP 0113 00). c. Replace damaged or faulty circuit breaker (WP 0074 00). <ol style="list-style-type: none"> a. If no voltage (24V) is found, remove panel in front of the brake pedals and check connections at the brake pressure switches 204-1 and 204-2 (WP 0098 00). b. With the brake pressure built up, check continuity of pressure switch 204-1 (WP 0113 00). c. Replace faulty pressure switch (WP 0098 00). <p>Repair or replace damaged wires or connectors (WP 0113 00).</p>

Table 3. Error Code 120 - Brake System Pressure, Circuit 2 Failure Troubleshooting Procedures.

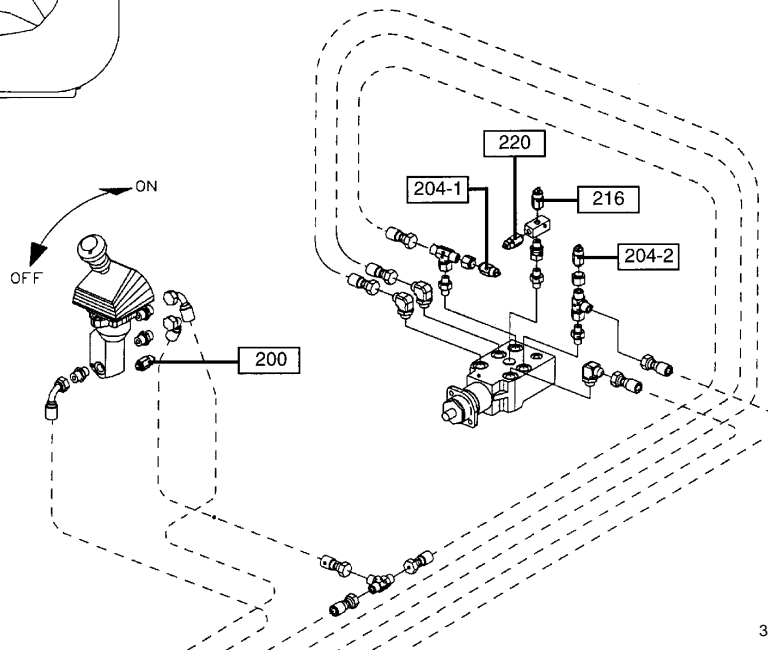
MALFUNCTION	TEST OR INSPECTION	CORRECTIVE ACTION
<p>Error Code 120 - Brake System Pressure, Circuit 2 Failure.</p>  <p>The image shows a diagnostic display with two warning icons at the top: a book icon and a circular icon with an exclamation mark. Below the icons, the text reads: 'EXTRA FUNCT. 7(13)', 'BRAKE CIRCUIT 1 0', and 'BRAKE CIRCUIT 2 0'.</p>	<ol style="list-style-type: none"> 1. Check if accumulator evacuation valves are open (WP 0164 00). 2. Check brake system pressures at test points 1 and 2 (WP 0187 00). 3. Enter "EXTRA FUNC" 7(13) in the diagnostic menu and check status of both brake circuits. 4. Check circuit breaker F3 for trip. 5. Start engine and allow brake pressure to built up. Check voltage (24V) at X150 pin 10 (WP 0048 00-7). 6. Check voltage (24V) at X18 pin 1 (WP 0048 00-36). 7. Check voltage (24V) at X18 pin 3 (WP 0048 00-36). 8. Check continuity of wires 181, A181, 183, A183, 296, and A15010 (WP 0048 00-7 and WP 0048 00-36). 	<p>Close accumulator evacuation valves.</p> <p>If pressure is not as specified, perform brake system troubleshooting (WP 0005 00).</p> <p>A "0" at either brake circuit would indicate an open pressure switch due to low brake pressure, faulty pressure switch or open circuit.</p> <p>Reset circuit breaker as required.</p> <ol style="list-style-type: none"> a. If no voltage (24V) is found, proceed with step 6. b. If voltage (24V) is present, disconnect ECU (790) connector 1 and inspect pin 41 for damage (WP 0048 00-7). <ol style="list-style-type: none"> a. If no voltage (24V) is found, check circuit breaker F3 and continuity of wires A266 and A181. b. Repair or replace damaged wires or connectors (WP 0113 00). c. Replace damaged or faulty circuit breaker (WP 0074 00). <ol style="list-style-type: none"> a. If no voltage (24V) is found, remove panel in front of the brake pedals and check connections at the brake pressure switches 204-1 and 204-2 (WP 0098 00). b. With the brake pressure built up, check continuity of pressure switch 204-2 (WP 0113 00). c. Replace faulty pressure switch (WP 0098 00). <p>Repair or replace damaged wires or connectors (WP 0113 00).</p>



230
853-1



NO.	EARTH CONNECTIONS
37-1	EARTH CONN. DISTR.UNIT
37-2	EARTH CONN. CAB ROOF
37-3	EARTH CONN. FRAME BATTERY
37-4	EARTH CONN. ENGINE
37-5	EARTH COMPUTERS
37-6	EARTH LIGHTS LEFT REAR
37-7	EARTH LIGHTS RIGHT REAR
37-8	EARTH LIGHTS LEFT FRONT
37-9	EARTH LIGHTS RIGHT FRONT
37-10	EARTH CAB FLOOR AC
37-50, 51	EARTH ELSERVO
37-52	EARTH STEERING ECS
37-54, 55	EARTH DISTR. UNIT ATTACHMENT
37-60	EARTH CAB FLOOR



350-1050

END OF WORK PACKAGE

AXLE BRAKE COOLING SYSTEM TROUBLESHOOTING

0032 00

THIS WORK PACKAGE COVERS

Error Code 191 - Temperature in Front Axle Above Critical Threshold

Error Code 414 - Brake Cooling Bypass Valve Short Circuit Failure

Error Code 192 - Temperature in Rear Axle Above Critical Threshold

INITIAL SETUP

References

- TM 10-3930-675-10
- ECS Steering (A34651.0200) (WP 0048 00-16)

References - Continued

- ECS Electrical Servo (A34648.0200) (WP 0048 00-5)



WARNING

Use caution when checking wheel and hub for extreme heat. Failure to do so may cause serious burns.

NOTE

Refer to WP 0004 00 for additional troubleshooting guidance, information, and illustrations that locate critical components.

Table 1. Error Code 191 - Temperature in Front Axle Above Critical Threshold Troubleshooting Procedures.


MALFUNCTION	TEST OR INSPECTION	CORRECTIVE ACTION
<p>Error Code 191 - Temperature in Front Axle Above Critical Threshold.</p> 	<p>1. Enter diagnostic menu "EXTRA FUNCT" 12(13). Check the temperature of WHEEL END FRONT.</p>	<p>a. The normal temperature should be under 95°F (35°C). b. If the temperature reads between 95 to 120°F (35 to 49°C), check the wheel hubs for temperature above 203°F (95°C). c. A reading of 155 indicates a possible short across the temperature sensor or circuit.</p>

Table 1. Error Code 191 - Temperature in Front Axle Above Critical Threshold Troubleshooting Procedures - Continued.

MALFUNCTION	TEST OR INSPECTION	CORRECTIVE ACTION
<p>Error Code 191 - Temperature in Front Axle Above Critical Threshold - Continued.</p>	<ol style="list-style-type: none"> 2. Enter diagnostic menu "EXTRA FUNCT" 12(13) to determine the brake cooling status. 3. Enter diagnostic menu "EXTRA FUNCT" 4(13) to determine the status of the fording switch. (Fording switch will cut off the cooling fan.) 4. Locate the temperature sensor 762-1 inside the left front hub. Disconnect the sensor and check the resistance of the sensor. Check resistance to ground. 5. Disconnect the ECU (790) connector 1 and the 762-1 sensor. Check for continuity to ground at ECU (790) connector 1 at pin 23 (WP 0048 00-7). 	<ol style="list-style-type: none"> a. Under normal or higher ambient temperatures, the BRAKE COOLING should be "1". Temperature should be under 95°F (35°C). b. If the value is "0", perform troubleshooting procedure for ERROR CODE 414 in Table 3 of this work package. a. The normal value should be "1". b. If the value is "0", perform troubleshooting procedure for ERROR CODE 426 (WP 0010 00). a. The sensor should have a measurable resistance but not shorted or open. b. The sensor should not have continuity to ground. c. Replace sensor if grounded, shorted, or open (WP 0093 00). a. If continuity to ground, isolate and check the following wires. b. Check for continuity to ground at wire A1562 (WP 0048 00-7). c. Check for continuity to ground at X156 pin 2 (WP 0048 00-7). d. Check for continuity to ground at X156 pin 2 (WP 0048 00-7). e. Repair or replace damaged wires or connectors (WP 0113 00). f. Replace shorted sensor harness (WP 0093 00).

Table 1. Error Code 191 - Temperature in Front Axle Above Critical Threshold Troubleshooting Procedures - Continued.

MALFUNCTION	TEST OR INSPECTION	CORRECTIVE ACTION
<p>Error Code 191 - Temperature in Front Axle Above Critical Threshold - Continued.</p>	<p>6. Enter the diagnostic menu "EXTRA FUNCT" 11(13). Check the fan operation. Use the +/- keys to change the fan speed and observe if the fan speed changes.</p> <p>7. Check hydraulic pressure at cooling fan hydraulic pump located at the left front of engine. Pressure should be 2,540 psi (175 bar) at full throttle with the fan at 100% "EXTRA FUNCT" 11(13).</p>	<p>a. If fan speed does not change, perform troubleshooting procedures for ERROR CODE 166 and 167 (WP 0010 00).</p> <p>b. If fan operates properly, replace front brake cooling bypass valve and filter (WP 0176 00).</p> <p>a. If pressure is not as specified or pressure does not change when changing fan speeds, replace cooling fan flow control valve (WP 0249 00).</p> <p>b. Perform cooling fan hydraulic pump maintenance (WP 0248 00) and/or replacement (WP 0247 00).</p>

Table 2. Error Code 192 - Temperature in Rear Axle Above Critical Threshold Troubleshooting Procedures.


MALFUNCTION	TEST OR INSPECTION	CORRECTIVE ACTION
<p data-bbox="159 443 719 499">Error Code 192 - Temperature in Rear Axle Above Critical Threshold.</p> 	<ol style="list-style-type: none"> <li data-bbox="732 443 1088 562">1. Enter diagnostic menu "EXTRA FUNCT" 12(13) Check temperature of WHEEL END REAR. <li data-bbox="732 779 1088 898">2. Enter diagnostic menu "EXTRA FUNCT" 12(13) to determine the brake cooling status. <li data-bbox="732 1052 1088 1234">3. Enter diagnostic menu "EXTRA FUNCT" 4(13) to determine the status of the fording switch. (Fording switch will cut off the cooling fan.) <li data-bbox="732 1262 1088 1444">4. Locate the temperature sensor 762-2 inside the left rear hub. Disconnect the sensor and check the resistance of the sensor. Check resistance to ground. <li data-bbox="732 1493 1088 1682">5. Disconnect the ECU (790) connector 1 and the 762-2 sensor. Check for continuity to ground at ECU (790) connector 1 at pin 29 (WP 0048 00-7). 	<ol style="list-style-type: none"> <li data-bbox="1104 443 1461 661">a. The normal temperature should be under 95°F (35°C). <li data-bbox="1104 661 1461 758">b. If the temperature reads between 95 to 120°F (35 to 49°C), check the wheel hubs for temperature above 203°F (95°C). <li data-bbox="1104 758 1461 821">c. A reading of 155 indicates a possible short across the temperature sensor or circuit. <li data-bbox="1104 821 1461 898">a. Under normal or higher ambient temperatures, the BRAKE COOLING should be "1". <li data-bbox="1104 898 1461 1031">b. If the value is "0", perform troubleshooting procedure for ERROR CODE 414 in Table 3 of this work package. <li data-bbox="1104 1031 1461 1108">a. The normal value should be "1". <li data-bbox="1104 1108 1461 1234">b. If the value is "0", perform troubleshooting procedure for ERROR CODE 426 (WP 0010 00). <li data-bbox="1104 1234 1461 1346">a. The sensor should have a measurable resistance but not shorted or open. <li data-bbox="1104 1346 1461 1409">b. The sensor should not have continuity to ground. <li data-bbox="1104 1409 1461 1472">c. Replace sensor if grounded, shorted or open (WP 0093 00). <li data-bbox="1104 1472 1461 1549">a. If continuity to ground, isolate and check the following wires. <li data-bbox="1104 1549 1461 1654">b. Check the continuity to ground at wire A1561 (WP 0048 00-7). <li data-bbox="1104 1654 1461 1717">c. Check for continuity to ground at X156 pin 1 (WP 0048 00-7).

Table 2. Error Code 192 - Temperature in Rear Axle Above Critical Threshold Troubleshooting Procedures - Continued.

MALFUNCTION	TEST OR INSPECTION	CORRECTIVE ACTION
<p>Error Code 192 - Temperature in Rear Axle Above Critical Threshold - Continued.</p>	<p>6. Enter diagnostic menu "EXTRA FUNCT" 11(13). Check the fan operation. Use the +/- keys to change the fan speed and observe if the fan speed changes.</p> <p>7. Check hydraulic pressure at cooling fan hydraulic pump located at the left front of engine. Pressure should be 2,540 psi (175 bar) at full throttle with the fan at 100% "EXTRA FUNCT" 11(13).</p>	<p>d. Check for continuity to ground at X168 pin 1 (WP 0048 00-7).</p> <p>e. Repair or replace damaged wires or connectors (WP 0113 00).</p> <p>f. Replace shorted sensor harness (WP 0092 00).</p> <p>a. If fan speed does not change; perform troubleshooting procedures for ERROR CODE 166 and 167 (WP 0010 00).</p> <p>b. If fan operates properly, replace front brake cooling bypass valve and filter (WP 0176 00).</p> <p>a. If pressure is not as specified or pressure does not change when changing fan speeds, replace cooling fan flow control valve (WP 0249 00).</p> <p>b. Perform cooling fan hydraulic pump maintenance (WP 0248 00) and/or replacement (WP 0247 00).</p>

Table 3. Error Code 414 - Brake Cooling Bypass Valve, Short Circuit Failure Troubleshooting Procedures.


MALFUNCTION	TEST OR INSPECTION	CORRECTIVE ACTION
<p>Error Code 414 - Brake Cooling Bypass Valve, Short Circuit Failure.</p> 	<p style="text-align: center;">NOTE</p> <p>Error code 414 is an information type error code. It may not activate for the operator. The operator may report the error codes 191 or 192 (brake overheating). Enter DIAG STEERING 2(16) in the diagnostic menu to verify the code or enable the information type codes in the Initialization menu.</p> <ol style="list-style-type: none"> 1. Test circuit. Place a jumper wire at connector X156 between pins 2 and 3 on the mounted part of the connector. DO NOT disconnect X156. This will activate the brake cooling circuit. 2. Check voltage (24V) at X156 pin 4 (WP 0048 00-7). 	<ol style="list-style-type: none"> a. If no voltage (24V) is found, move the cab to the transport position to access X168 under the cover plate. Disconnect X168 pin 4 wire BU and recheck. b. If voltage is still not found, disconnect X156 and check wire BU for continuity to ground (WP 0048 00-7). c. Replace grounded X156 to X168 cable (WP 0113 00).

Table 3. Error Code 414 - Brake Cooling Bypass Valve, Short Circuit Failure Troubleshooting Procedures - Continued.

MALFUNCTION	TEST OR INSPECTION	CORRECTIVE ACTION
<p>Error Code 414 - Brake Cooling Bypass Valve, Short Circuit Failure - Continued.</p>	<p>3. Check resistance. Disconnect the rear brake cooling bypass solenoid 6049-2 located under the vehicle just behind the cab. Check resistance at X168 between pins 3 and 4 (WP 0048 00-7). Resistance should be 26 to 32 Ohms.</p> <p>4. Check resistance. Disconnect the rear brake cooling bypass solenoid 6049-2 and check resistance of solenoid coil. Resistance should be 26 to 32 Ohms with no continuity to ground.</p> <p>5. Check wire A1564 (WP 0048 00-7) and wires 16012 and A17712 (WP 0048 00-19) for continuity and for continuity to ground.</p> <p>6. Check ECU (792) pin 58 for connection or damage (WP 0048 00-19).</p>	<p>a. If resistance is not as specified, remove the radiator splash shield to access the front brake cooling bypass valve (WP 0143 00).</p> <p>b. Disconnect brake cooling bypass solenoid 6049-1 and check resistance of solenoid coil. Resistance should be 36 to 32 Ohms with no continuity to ground.</p> <p>c. If resistance is as specified, check wires GY and BK to the 6049-1 connector for short or ground (WP 0048 00-7).</p> <p>d. Replace shorted or grounded front brake cooling bypass valve or connector cable (WP 0113 00).</p> <p>a. If resistance is not as specified, replace the rear brake cooling bypass valve (WP 0142 00).</p> <p>b. If resistance is as specified, check wires GY and BK to the 6049-2 connector for short or ground (WP 0048 00-7).</p> <p>c. Replace shorted or grounded 6049-2 connector cable (WP 0113 00).</p> <p>a. Replace damaged or grounded wire.</p> <p>b. Repair or replace damaged connector (WP 0113 00).</p> <p>a. Replace damaged ECU (792) terminal board (WP 0080 00).</p> <p>b. Replace ECU (792) (WP 0080 00).</p>

END OF WORK PACKAGE

STEERING VALVE CIRCUIT TROUBLESHOOTING

0033 00

THIS WORK PACKAGE COVERS

- Error Code 325 - Right-Front Wheel Valve Solenoid, Broken Circuit Failure
- Error Code 326 - Right-Rear Wheel Valve Solenoid, Broken Circuit Failure
- Error Code 327 - Left-Rear Wheel Valve Solenoid, Broken Circuit Failure
- Error Code 328 - Left-Front Wheel Valve Solenoid, Broken Circuit Failure
- Error Code 329 - Right-Front Wheel Valve Solenoid, Short Circuit Failure
- Error Code 330 - Right-Rear Wheel Valve Solenoid, Short Circuit Failure
- Error Code 331 - Left-Rear Wheel Valve Solenoid, Short Circuit Failure

- Error Code 332 - Left-Front Wheel Valve Solenoid, Short Circuit Failure
- Error Code 339 - Grounding of Steering Wheel Sensor is Interrupted
- Error Code 340 - Hydraulic Steering Pressure Below Critical Threshold [1450 psi (100 bar)]
- Error Code 341 - Steering Wheel Signal Not Consistent
- Error Code 342 - One Steering Wheel Signal is Interrupted
- Error Code 343 - One Steering Wheel Signal is Interrupted
- Error Code 344 - Both Steering Wheel Signals are Interrupted
- Error Code 347 - No Steering Mode Selected

INITIAL SETUP

References

- TM 10-3930-675-10
- ECS Steering (A34651.0200) (WP 0048 00-16)

Equipment Condition

Cab moved to transport position (TM 10-3930-675-10-1)

NOTE

Refer to WP 0004 00 for additional troubleshooting guidance, information, and illustrations that locate critical components.

Table 1. Error Code 325 - Right-Front Wheel Valve Solenoid, Broken Circuit Failure Troubleshooting Procedures.


MALFUNCTION	TEST OR INSPECTION	CORRECTIVE ACTION
<p>Error Code 325 - Right-Front Wheel Valve Solenoid, Broken Circuit Failure.</p> 	<p>1. Disconnect X196 located behind seat in the middle panel. Check the resistance between pin 1 and 2 on the loose part of the X196 connector (WP 0048 00-22). Resistance should be 12 to 14 Ohms.</p>	<p>a. If resistance is not as specified, continue with step 3. b. If resistance is as specified, continue with troubleshooting procedure.</p>

Table 1. Error Code 325 - Right-Front Wheel Valve Solenoid, Broken Circuit Failure Troubleshooting Procedures - Continued.

MALFUNCTION	TEST OR INSPECTION	CORRECTIVE ACTION
<p>Error Code 325 - Right-Front Wheel Valve Solenoid, Broken Circuit Failure - Continued.</p>	<p>2. Check resistance at X196 between pins 3 and 4 (WP 0048 00-22). Resistance should be 12 to 14 Ohms.</p> <p>3. Move cab to the transport position (TM 10-3930-675-10). Remove the hydraulic pump cover. Locate the steering valve on the inside of the left frame rail.</p> <p>4. Disconnect the 6026 connector and check the resistance of the 6026 solenoid. The resistance should be 12 to 13 Ohms. Check resistance of each pin to ground. There should not be continuity to ground.</p> <p>5. Disconnect the 6027 connector and check the resistance of the 6027 solenoid. Resistance should be 12 to 13 Ohms. Check resistance of each pin to ground. There should not be continuity to ground.</p> <p>6. Inspect ECU (792) pins 8, 10, 27, and 28 for connection or damage. Check continuity of wires A1961, A1962, A1963, and A1964 (WP 0048 00-22).</p>	<p>a. If resistance is not as specified, continue with troubleshooting procedure.</p> <p>b. If resistance is as specified, inspect the mounted part of X196 for damage or pushed back pins. Continue with step 6.</p> <p>c. Repair or replace damaged connector (WP 0113 00).</p> <p>a. If resistance is not as specified, replace open, shorted, or grounded solenoid (WP 0171 00).</p> <p>b. If resistance is as specified, check continuity of wires 1961 and 1962 (WP 0048 00-22).</p> <p>c. Replace open or damaged X196 wiring harness (WP 0113 00).</p> <p>a. If resistance is not as specified, replace open, shorted, or grounded solenoid (WP 0171 00).</p> <p>b. If resistance is as specified, check continuity of wires 1961 and 1962 (WP 0048 00-22).</p> <p>c. Replace open or damaged X196 wiring harness (WP 0113 00).</p> <p>a. Replace damaged ECU (792) terminal board (WP 0080 00).</p> <p>b. Repair or replace damaged wires or connectors (WP 0113 00).</p>

Table 2. Error Code 326 - Right-Rear Wheel Valve Solenoid, Broken Circuit Failure Troubleshooting Procedures.

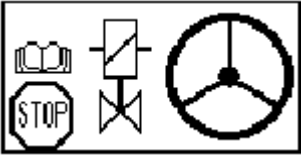
MALFUNCTION	TEST OR INSPECTION	CORRECTIVE ACTION
<p>Error Code 326 - Right-Rear Wheel Valve Solenoid, Broken Circuit Failure.</p> 	<ol style="list-style-type: none"> 1. Disconnect X196 located behind seat in the middle panel. Check the resistance between pins 9 and 10 on the loose part of the X196 connector (WP 0048 00-22). Resistance should be 12 to 14 Ohms. 2. Check resistance at X196 between pins 11 and 12 (WP 0048 00-22). Resistance should be 12 to 14 Ohms. 3. Move cab to the transport positions (TM 10-3930-675-10). Remove the hydraulic pump cover. Locate the steering valve on the inside of the left frame rail. 4. Disconnect the 6030 connector and check the resistance of the 6030 solenoid. Resistance should be 12 to 13 Ohms. Check resistance of each pin to ground. There should not be continuity to ground. 	<ol style="list-style-type: none"> a. If resistance is not as specified, continue with step 3. b. If resistance is as specified, continue with troubleshooting procedure. a. If resistance is not as specified, continued with troubleshooting procedure. b. If resistance is as specified, inspect the mounted part of X196 for damage or pushed back pins. Continue with step 6. c. Repair or replace damaged connector (WP 0113 00). a. If resistance is not as specified, replace open, shorted, or grounded solenoid (WP 0171 00). b. If resistance is as specified, check continuity of wires 1969 and 19610 (WP 0048 00-22). c. Replace open or damaged X196 wiring harness (WP 0113 00).

Table 2. Error Code 326 - Right-Rear Wheel Valve Solenoid, Broken Circuit Failure Troubleshooting Procedures - Continued.

MALFUNCTION	TEST OR INSPECTION	CORRECTIVE ACTION
Error Code 326 - Right-Rear Wheel Valve Solenoid, Broken Circuit Failure - Continued.	5. Disconnect the 6031 connector and check the resistance of the 6031 solenoid. Resistance should be 12 to 13 Ohms. Check resistance of each pin to ground. There should not be continuity to ground. 6. Inspect ECU (792) pins 9, 11, 12, and 13 for connection or damage. Check continuity of wires A1969, A19610, A19611, and A19612 (WP 0048 00-22).	a. If resistance is not as specified, replace open, shorted, or grounded solenoid (WP 0171 00). b. If resistance is as specified, check continuity of wires 19611 and 19612 (WP 0048 00-22). c. Replace open or damaged X196 wiring harness (WP 0113 00). a. Replace damaged ECU (792) terminal board (WP 0080 00). b. Repair or replace damaged wires or connectors (WP 0113 00).

Table 3. Error Code 327 - Left-Rear Wheel Valve Solenoid, Broken Circuit Failure Troubleshooting Procedures.


MALFUNCTION	TEST OR INSPECTION	CORRECTIVE ACTION
Error Code 327 - Left-Rear Wheel Valve Solenoid, Broken Circuit Failure. 	1. Disconnect X196 and X197 located behind seat in the middle panel. Check the resistance between pins 13 and 14 on the loose part of the X196 connector (WP 0048 00-22). Resistance should be 12 to 14 Ohms. 2. Check resistance at X197 between pins 1 and 2 (WP 0048 00-22). Resistance should be 12 to 14 Ohms.	a. If resistance is not as specified, continue with step 3. b. If resistance is as specified, continue with troubleshooting procedure. a. If resistance is not as specified, continue with troubleshooting procedure. b. If resistance is as specified, inspect the mounted part of X196 and X197 for damage or pushed back pins. Continue with step 6. c. Repair or replace damaged connector (WP 0113 00).

Table 3. Error Code 327 - Left-Rear Wheel Valve Solenoid, Broken Circuit Failure Troubleshooting Procedures - Continued.

MALFUNCTION	TEST OR INSPECTION	CORRECTIVE ACTION
<p>Error Code 327 - Left-Rear Wheel Valve Solenoid, Broken Circuit Failure - Continued.</p>	<p>3. Move cab to the transport position (TM 10-3930-6765-10). Remove the hydraulic pump cover. Locate the steering valve on the inside of the left frame rail.</p> <p>4. Disconnect the 6032 connector and check the resistance of the 6032 solenoid. Resistance should be 12 to 13 Ohms. Check resistance of each pin to ground. There should not be continuity to ground.</p> <p>5. Disconnect the 6033 connector and check the resistance of the 6033 solenoid. Resistance should be 12 to 13 Ohms. Check resistance of each pin to ground. There should not be continuity to ground.</p> <p>6. Inspect ECU (792) pins 14, 15, 16, and 18 for connection or damage. Check continuity of wires A19613, A19614, A1971, and A1972 (WP 0048 00-22).</p>	<p>a. If resistance is not as specified, replace open, shorted, or grounded solenoid (WP 0171 00).</p> <p>b. If resistance is as specified, check continuity of wires 19613 and 19614 (WP 0048 00-22).</p> <p>c. Replace open or damaged X196 wiring harness (WP 0113 00).</p> <p>a. If resistance is not as specified, replace open, shorted, or grounded solenoid (WP 0171 00).</p> <p>b. If resistance is as specified, check continuity of wires 1971 and 1972 (WP 0048 00-22).</p> <p>c. Replace open or damaged X197 wiring harness (WP 0113 00).</p> <p>a. Replace damaged ECU (792) terminal board (WP 0080 00).</p> <p>b. Repair or replace damaged wires or connectors (WP 0113 00).</p>

Table 4. Error Code 328 - Left-Front Wheel Valve Solenoid, Broken Circuit Failure Troubleshooting Procedures.

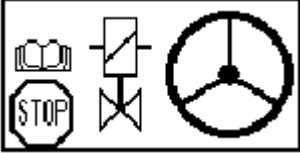
MALFUNCTION	TEST OR INSPECTION	CORRECTIVE ACTION
<p>Error Code 328 - Left-Front Wheel Valve Solenoid, Broken Circuit Failure.</p> 	<ol style="list-style-type: none"> 1. Disconnect X196 located behind seat in the middle panel. Check the resistance between pins 5 and 6 on the loose part of the X196 connector (WP 0048 00-22). Resistance should be 12 to 14 Ohms. 2. Check resistance at X196 between pins 7 and 8 (WP 0048 00-22). Resistance should be 12 to 14 Ohms. 3. Move cab to the transport position (TM 10-3930-675-10). Remove the hydraulic pump cover. Locate the steering valve on the inside of the left frame rail. 4. Disconnect the 6028 connector and check the resistance of the 6028 solenoid. Resistance should be 12 to 13 Ohms. Check resistance of each pin to ground. There should not be continuity to ground. 	<ol style="list-style-type: none"> a. If resistance is not as specified, continue with step 3. b. If resistance is as specified, continue with troubleshooting procedure. a. If resistance is not as specified, continue with troubleshooting procedure. b. If resistance is as specified, inspect the mounted part of X196 for damage or pushed back pins. Continue with step 6. c. Repair or replace damaged connector (WP 0113 00). a. If resistance is not as specified, replace open, shorted, or grounded solenoid (WP 0171 00). b. If resistance is as specified, check continuity of wires 1965 and 1966 (WP 0048 00-22). c. Replace open or damaged X196 wiring harness (WP 0113 00).

Table 4. Error Code 328 - Left-Front Wheel Valve Solenoid, Broken Circuit Failure Troubleshooting Procedures - Continued.

MALFUNCTION	TEST OR INSPECTION	CORRECTIVE ACTION
<p>Error Code 328 - Left-Front Wheel Valve Solenoid, Broken Circuit Failure - Continued.</p>	<p>5. Disconnect the 6029 connector and check the resistance of the 6029 solenoid. Resistance should be 12 to 13 Ohms. Check resistance of each pin to ground. There should not be continuity to ground.</p> <p>6. Inspect ECU (792) pins 17, 19, 20, and 22 for connection or damage. Check continuity of wires A1965, A1966, A1967, and A1968 (WP 0048 00-22).</p>	<p>a. If resistance is not as specified, replace open, shorted, or grounded solenoid (WP 0171 00).</p> <p>b. If resistance is as specified, check continuity of wire 1967 and 1968 (WP 0048 00-22).</p> <p>c. Notify Sustainment Maintenance to replace open or damaged X196 wiring harness.</p> <p>a. Replace damaged ECU (792) terminal board (WP 0080 00).</p> <p>b. Repair or replace damaged wires or connectors (WP 0113 00).</p>

Table 5. Error Code 329 - Right-Front Wheel Valve Solenoid, Short Circuit Failure Troubleshooting Procedures.

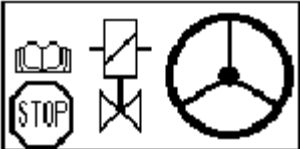
MALFUNCTION	TEST OR INSPECTION	CORRECTIVE ACTION
<p>Error Code 329 - Right-Front Wheel Valve Solenoid, Short Circuit Failure.</p> 	<p>1. Disconnect X196 located behind seat in the middle panel. Check the resistance between pins 1 and 2 on the loose part of the X196 connector (WP 0048 00-22). Resistance should be 12 to 14 Ohms.</p> <p>2. Check resistance at X196 between pins 3 and 4 (WP 0048 00-22). Resistance should be 12 to 14 Ohms.</p>	<p>a. If resistance is not as specified, continue with step 3.</p> <p>b. If resistance is as specified, continue with troubleshooting procedure.</p> <p>a. If resistance is not as specified, continue with troubleshooting procedure.</p> <p>b. If resistance is as specified, inspect the mounted part of X196 for damage or pushed back pins. Continue with step 6.</p> <p>c. Repair or replace damaged connector (WP 0113 00).</p>

Table 5. Error Code 329 - Right-Front Wheel Valve Solenoid, Short Circuit Failure Troubleshooting Procedures - Continued.

MALFUNCTION	TEST OR INSPECTION	CORRECTIVE ACTION
<p>Error Code 329 - Right-Front Wheel Valve Solenoid, Short Circuit Failure - Continued.</p>	<p>3. Move cab to the transport position (TM 10-3930-675-10). Remove the hydraulic pump cover. Locate the steering valve on the inside of the left frame rail.</p> <p>4. Disconnect the 6026 connector and check the resistance of the 6026 solenoid. Resistance should be 12 to 13 Ohms. Check resistance of each pin to ground. There should not be continuity to ground.</p> <p>5. Disconnect the 6027 connector and check the resistance of the 6027 solenoid. Resistance should be 12 to 13 Ohms. Check resistance of each pin to ground. There should not be continuity to ground.</p> <p>6. Inspect ECU (792) pin 8, 10, 27, and 28 for connection or damage. Check continuity of wires A1961, A1963, and A1964 to ground and between each other (WP 0048 00-22).</p>	<p>a. If resistance is not as specified, replace open, shorted, or grounded solenoid (WP 0171 00).</p> <p>b. If resistance is as specified, check continuity of wires 1961 and 1962 to ground and between each other (WP 0048 00-22).</p> <p>c. Notify Sustainment Maintenance to replace shorted, grounded, or damaged X196 wiring harness.</p> <p>a. If resistance is not as specified, replace open, shorted, or grounded solenoid (WP 0171 00).</p> <p>b. If resistance is as specified, check continuity of wires 1963 and 1964 to ground and between each other (WP 0048 00-22).</p> <p>c. Notify Sustainment Maintenance to replace shorted, grounded, or damaged X196 wiring harness.</p> <p>a. Replace damaged ECU (792) terminal board (WP 0080 00).</p> <p>b. Repair or replace shorted, grounded, damaged wires, or connectors (WP 0113 00).</p>

Table 6. Error Code 330 - Right-Rear Wheel Valve Solenoid, Short Circuit Failure Troubleshooting Procedures.

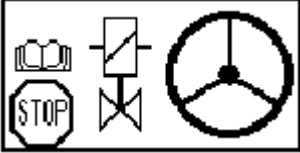
MALFUNCTION	TEST OR INSPECTION	CORRECTIVE ACTION
<p data-bbox="159 443 719 499">Error Code 330 - Right-Rear Wheel Valve Solenoid, Short Circuit Failure.</p> 	<ol style="list-style-type: none"> <li data-bbox="732 443 1088 688">1. Disconnect X196 located behind seat in the middle panel. Check the resistance between pins 9 and 10 on the loose part of the X196 connector (WP 0048 00-22). Resistance should be 12 to 14 Ohms. <li data-bbox="732 716 1088 835">2. Check resistance at X196 between pins 11 and 12 (WP 0048 00-22). Resistance should be 12 to 14 Ohms. <li data-bbox="732 1062 1088 1245">3. Move cab to the transport position (TM 10-3930-675-10). Remove the hydraulic pump cover. Locate the steering valve on the inside of the left frame rail. <li data-bbox="732 1272 1088 1486">4. Disconnect the 6030 connector and check the resistance of the 6030 solenoid. Resistance should be 12 to 13 Ohms. Check resistance of each pin to ground. There should not be continuity to ground. 	<ol style="list-style-type: none"> <li data-bbox="1104 443 1456 499">a. If resistance is not as specified, continue with step 3. <li data-bbox="1104 516 1456 604">b. If resistance is as specified, continued with troubleshooting procedure. <li data-bbox="1104 716 1456 804">a. If resistance is not as specified, continue with troubleshooting procedure <li data-bbox="1104 821 1456 968">b. If resistance is as specified, inspect the mounted part of X196 for damage or pushed back pins. Continue with step 6. <li data-bbox="1104 984 1456 1041">c. Repair or replace damaged connector (WP 0113 00). <li data-bbox="1104 1272 1456 1392">a. If resistance is not as specified, replace open, shorted, or grounded solenoid (WP 0171 00). <li data-bbox="1104 1409 1456 1556">b. If resistance is as specified, check continuity of wires 1969 and 19610 to ground and between each other (WP 0048 00-22). <li data-bbox="1104 1572 1456 1724">c. Notify Sustainment Maintenance to replace shorted, grounded, or damaged X196 wiring harness.

Table 6. Error Code 330 - Right-Rear Wheel Valve Solenoid, Short Circuit Failure Troubleshooting Procedures - Continued.

MALFUNCTION	TEST OR INSPECTION	CORRECTIVE ACTION
<p>Error Code 330 - Right-Rear Wheel Valve Solenoid, Short Circuit Failure - Continued.</p>	<p>5. Disconnect the 6031 connector and check the resistance of the 6031 solenoid. Resistance should be 12 to 13 Ohms. Check resistance of each pin to ground. There should not be continuity to ground.</p> <p>6. Inspect ECU (792) pins 9, 11, 12, and 13 for connection or damage. Check continuity of wires A1969, A19610, A1911, and A1912 to ground and between each other (WP 0048 00-22).</p>	<p>a. If resistance is not as specified, replace open shorted, or grounded solenoid (WP 0171 00).</p> <p>b. If resistance is as specified, check continuity of wires 19611 and 19612 to ground and between each other (WP 0048 00-22).</p> <p>c. Notify Sustainment Maintenance to replace shorted, grounded, or damaged X196 wiring harness.</p> <p>a. Replace damaged ECU (792) terminal board (WP 0080 00).</p> <p>b. Repair or replace shorted, grounded, damaged wires, or connectors (WP 0113 00).</p>

Table 7. Error Code 331 - Left-Rear Wheel Valve Solenoid, Short Circuit Failure Troubleshooting Procedures.

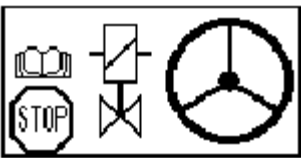
MALFUNCTION	TEST OR INSPECTION	CORRECTIVE ACTION
<p>Error Code 331 - Left-Rear Wheel Valve Solenoid, Short Circuit Failure.</p> 	<p>1. Disconnect X196 and X197 located behind seat in the middle panel. Check the resistance between pins 13 and 14 on the loose part of the X196 connector (WP 0048 00-22). Resistance should be 12 to 14 Ohms.</p> <p>2. Check resistance at X197 between pins 1 and 2 (WP 0048 00-22). Resistance should be 12 to 14 Ohms.</p>	<p>a. If resistance is not as specified, continue with step 3.</p> <p>b. If resistance is as specified, continue with troubleshooting procedure.</p> <p>a. If resistance is not as specified, continue with troubleshooting procedure.</p> <p>b. If resistance is as specified, inspect the mounted part of X196 and X197 for damage or pushed back pins. Continue with step 6.</p> <p>c. Repair or replace damaged connector (WP 0113 00).</p>

Table 7. Error Code 331 - Left-Rear Wheel Valve Solenoid, Short Circuit Failure Troubleshooting Procedures - Continued.

MALFUNCTION	TEST OR INSPECTION	CORRECTIVE ACTION
<p>Error Code 331 - Left-Rear Wheel Valve Solenoid, Short Circuit Failure - Continued.</p>	<p>3. Move cab to the transport position (TM 10-3930-675-10). Remove the hydraulic pump cover. Locate the steering valve on the inside of the left frame rail.</p> <p>4. Disconnect the 6032 connector and check the resistance of the 6032 solenoid. Resistance should be 12 to 13 Ohms. Check resistance of each pin to ground. There should not be continuity to ground.</p> <p>5. Disconnect the 6033 connector and check the resistance of the 6033 solenoid. Resistance should be 12 to 13 Ohms. Check resistance of each pin to ground. There should not be continuity to ground.</p> <p>6. Inspect ECU (792) pins 14, 15, 16, and 18 for connection or damage. Check continuity of wires A19613, A19614, A1971, and A1972 to ground and between each other (WP 0048 00-22).</p>	<p>a. If resistance is not as specified, replace open, shorted, or grounded solenoid (WP 0171 00).</p> <p>b. If resistance is as specified, check continuity of wires 19613 and 19614 to ground between each other (WP 0048 00-22).</p> <p>c. Notify Sustainment Maintenance replace shorted, grounded, or damaged X196 wiring harness.</p> <p>a. If resistance not as specified, replace open, shorted, or grounded solenoid (WP 0171 00).</p> <p>b. If resistance is as specified, check continuity of wires 1971 and 1972 to ground between each other (WP 0048 00-22).</p> <p>c. Notify Sustainment Maintenance replace shorted, grounded, or damaged X197 wiring harness.</p> <p>a. Replace damaged ECU (792) terminal board (WP 0080 00).</p> <p>b. Repair or replace shorted, grounded, damaged wires, or connectors (WP 0113 00).</p>

Table 8. Error Code 332 - Left-Front Wheel Valve Solenoid, Short Circuit Failure Troubleshooting Procedures.

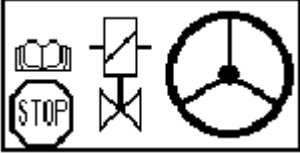
MALFUNCTION	TEST OR INSPECTION	CORRECTIVE ACTION
<p data-bbox="159 443 717 499">Error Code 332 - Left-Front Wheel Valve Solenoid, Short Circuit Failure.</p> 	<ol style="list-style-type: none"> <li data-bbox="732 443 1089 688">1. Disconnect X196 located behind seat in the middle panel. Check the resistance between pins 5 and 6 on the loose part of the X196 connector (WP 0048 00-22). Resistance should be 12 to 14 Ohms. <li data-bbox="732 716 1089 835">2. Check resistance at X196 between pins 7 and 8 (WP 0048 00-22). Resistance should be 12 to 14 Ohms. <li data-bbox="732 1062 1089 1245">3. Move cab to the transport position (TM 10-3930-675-10). Remove the hydraulic pump cover. Locate the steering valve on the inside of the left frame rail. <li data-bbox="732 1272 1089 1486">4. Disconnect the 6028 connector and check the resistance of the 6028 solenoid. Resistance should be 12 to 13 Ohms. Check resistance of each pin to ground. There should not be continuity to ground. 	<ol style="list-style-type: none"> <li data-bbox="1105 443 1456 499">a. If resistance is not as specified, continue with step 3. <li data-bbox="1105 516 1456 604">b. If resistance is as specified, continue with troubleshooting procedure. <li data-bbox="1105 716 1456 804">a. If resistance is not as specified, continue with troubleshooting procedure. <li data-bbox="1105 821 1456 968">b. If resistance is as specified, inspect the mounted part of X196 for damage or pushed back pins. Continue with step 6. <li data-bbox="1105 984 1456 1041">c. Repair or replace damaged connector (WP 0113 00). <li data-bbox="1105 1272 1456 1392">a. If resistance is not as specified, replace open, shorted, or grounded solenoid (WP 0171 00). <li data-bbox="1105 1409 1456 1556">b. If resistance is as specified, check continuity of wires 1965 and 1966 to ground and between each other (WP 0048 00-22). <li data-bbox="1105 1572 1456 1724">c. Notify Sustainment Maintenance to replace shorted, grounded, or damaged X196 wiring harness.

Table 8. Error Code 332 - Left-Front Wheel Valve Solenoid, Short Circuit Failure Troubleshooting Procedures - Continued.

MALFUNCTION	TEST OR INSPECTION	CORRECTIVE ACTION
<p>Error Code 332 - Left-Front Wheel Valve Solenoid, Short Circuit Failure - Continued.</p>	<p>5. Disconnect the 6029 connector and check the resistance of the 6029 solenoid. Resistance should be 12 to 13 Ohms. Check resistance of each pin to ground. There should not be continuity to ground.</p> <p>6. Inspect ECU (792) pins 17, 19, 20, and 22 for connection or damage. Check continuity of wires A1965, A1966, A1967, and A1968 to ground and between each other (WP 0048 00-22).</p>	<p>a. If resistance is not as specified, replace open, shorted, or grounded solenoid (WP 0171 00).</p> <p>b. If resistance is as specified, check continuity of wires 1967 and 1968 to ground and between each other (WP 0048 00-22).</p> <p>c. Notify Sustainment Maintenance to replace shorted, grounded, or damaged X196 wiring harness.</p> <p>a. Replace damaged ECU (792) terminal board (WP 0080 00).</p> <p>b. Repair or replace shorted, grounded, damaged wires, or connectors (WP 0113 00).</p>

Table 9. Error Code 339 - Grounding of Steering Wheel Sensor is Interrupted (USMC Only) Troubleshooting Procedures.


MALFUNCTION	TEST OR INSPECTION	CORRECTIVE ACTION
<p>Error Code 339 - Grounding of Steering Wheel Sensor is Interrupted (USMC Only).</p> 	<p>Perform troubleshooting procedure for error code 341 (WP 0033 00).</p>	

Table 10. Error Code 340 - Hydraulic Steering Pressure Below Threshold [1,450 psi (100 Bar)] Troubleshooting Procedures.


MALFUNCTION	TEST OR INSPECTION	CORRECTIVE ACTION
<p data-bbox="159 443 719 499">Error Code 340 - Hydraulic Steering Pressure Below Threshold [1,450 psi (100 Bar)].</p> 	<ol style="list-style-type: none"> <li data-bbox="732 443 1088 531">1. Ensure that steering accumulator evacuation valve is closed. <li data-bbox="732 554 1088 705">2. Check pumps. Enter DIAG EXTRA FUNCT 2(13) in the diagnostic menu. Use the +/- keys to turn pumps off and then back on. <li data-bbox="732 800 1088 919">3. Enter DIAG STEERING 5(16) in the diagnostic menu and check the status of the pressure switch. <li data-bbox="732 942 1088 999">4. Check steering pressure at test point 3 (WP 0188 00). <li data-bbox="732 1356 1088 1633">5. Move cab to the transport position (TM 10-3930-675-10) and remove the middle access cover (WP 0142 00) to access the steering valve. Check pressure switch (245) mounted on the top of the steering valve for damage and connection. 	<p data-bbox="1104 443 1455 531">Close steering accumulator evacuation valve as required (WP 0164 00).</p> <ol style="list-style-type: none"> <li data-bbox="1104 554 1455 642">a. Listen for a change in engine LOADING when pumps are turned off and on. <li data-bbox="1104 653 1455 772">b. If no change is heard or felt, perform troubleshooting procedure for error code 172 (WP 0038 00). <p data-bbox="1104 800 1455 888">If the steering pressure is above 1,450 psi (100 bar), the status will be "1".</p> <ol style="list-style-type: none"> <li data-bbox="1104 942 1455 1031">a. If no or low stabilized pressure, check pressure at test points 6 and 7 (WP 0188 00). <li data-bbox="1104 1041 1455 1199">b. If steering response is slow at idle or pressure is unstable, check the nitrogen pressure and charge the steering accumulator (WP 0231 00). <li data-bbox="1104 1209 1455 1329">c. If no or low pressure at test point 6 or 7, replace the steering and tophandler pump assembly (WP 0242 00). <ol style="list-style-type: none"> <li data-bbox="1104 1356 1455 1413">a. Replace damaged pressure switch (245) (WP 0134 00). <li data-bbox="1104 1423 1455 1480">b. Repair connector (WP 0113 00).

Table 10. Error Code 340 - Hydraulic Steering Pressure Below Threshold [1,450 psi (100 Bar)] Troubleshooting Procedures - Continued.

MALFUNCTION	TEST OR INSPECTION	CORRECTIVE ACTION
<p>Error Code 340 - Hydraulic Steering Pressure Below Threshold [1,450 psi (100 Bar)] - Continued.</p>	<p>6. Check voltage (24V) at X197 pin 3 with the ignition ON.</p> <p>7. Check voltage (24V) at X197 pin 4 with the engine running.</p> <p>8. Disconnect pressure switch (245). Open the steering accumulator evacuation valve and drain off the pressure (WP 0164 00). Close the valve. Check continuity between the two pins of pressure switch (245). There should not be continuity. Start the engine (TM 10-3930-675-10) and recheck continuity after the steering pressure stabilizes. There should be continuity.</p>	<p>a. If no voltage (24V) is found, check circuit breaker F29 and continuity of wires A473 (WP 0048 00-32), 473, and A1743B (WP 0048 00-16 and WP 0048 00-18) (ARMY only).</p> <p>b. If no voltage (24V) is found, check circuit breaker F33 and continuity of wires A475, 475, and A174B1A (WP 0048 00-18) (RESET and USMC only).</p> <p>c. Replace damaged or faulty circuit breaker (WP 0074 00).</p> <p>d. Repair or replace damaged wires or connectors (WP 0113 00).</p> <p>a. If no voltage (24V) is found, check continuity of wires 1973 and 1974 (WP 0048 00-18).</p> <p>b. Notify Sustainment Maintenance to replace open or damaged X197 harness.</p> <p>a. If pressure switch (245) does not have continuity after engine start, replace pressure switch (245) (WP 0134 00).</p> <p>b. If pressure switch (245) does have continuity after engine start, check continuity of wire A1974 and condition and connection at ECU (792) pin 49.</p> <p>c. Repair or replace damaged wires or connectors (WP 0113 00).</p> <p>d. Replace damaged ECU (792) terminal board (WP 0080 00).</p>

Table 11. Error Code 341 - Steering Wheel Signal Not Consistent Troubleshooting Procedures.


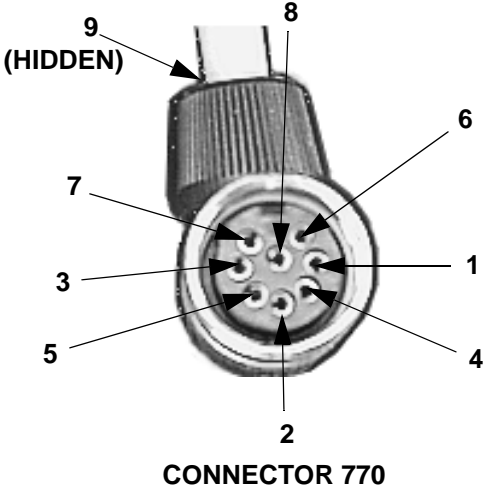
MALFUNCTION	TEST OR INSPECTION	CORRECTIVE ACTION
<p>Error Code 341 - Steering Wheel Signal Not Consistent.</p>   <p style="text-align: center;">CONNECTOR 770</p>	<ol style="list-style-type: none"> 1. Check steering column sensor (770) for damage and connection. 2. Check connector X176 located in the middle panel for damage and connection. 3. Disconnect steering column sensor (770) cable and connector X176. Check continuity of wires BN (pin 1), YE (pin 2), BU (pin 3), GN (pin 4), GY (pin 5), WH (pin 6), RD (pin 7), PK (pin 8), and shield (pin 9) (WP 0048 00-17). 4. Check continuity of wires A1761, A1762, A1763, A1764, A1765, A1766, A1767, A1768, and A1769 (WP 0048 00-17). 5. Check ECU (792) pins 23, 38, 40, 41, 56, 96, 97, 113, and 132 for damage or connection (WP 0048 00-17). 	<ol style="list-style-type: none"> a. Reconnect sensor cable if loose or disconnected. b. Replace damaged steering column sensor (770) (WP 0136 00). <p>Repair or replace damaged connector (WP 0113 00).</p> <p>If continuity is not found at any one wire, replace X176 to (770) cable (WP 0136 00).</p> <p>If continuity is not found at any one wire, replace damaged wire or connector (WP 0113 00).</p> <ol style="list-style-type: none"> a. Reconnect loose or disconnected wire or replace damaged ECU (792) terminal board. b. If all connections and continuity checks are correct, replace steering column sensor (770) (WP 0136 00).

Table 12. Error Code 342 - One Steering Wheel Signal is Interrupted Troubleshooting Procedures.


MALFUNCTION	TEST OR INSPECTION	CORRECTIVE ACTION
<p>Error Code 342 - One Steering Wheel Signal is Interrupted.</p> 	<p>Perform troubleshooting procedure for error code 341 (WP 0033 00).</p>	

Table 13. Error Code 343 - One Steering Wheel Signal is Interrupted Troubleshooting Procedures.


MALFUNCTION	TEST OR INSPECTION	CORRECTIVE ACTION
<p>Error Code 343 - One Steering Wheel Signal is Interrupted.</p> 	<p>Perform troubleshooting procedure for error code 341 (WP 0033 00).</p>	

Table 14. Error Code 344 - Both Steering Wheel Signals are Interrupted Troubleshooting Procedures.


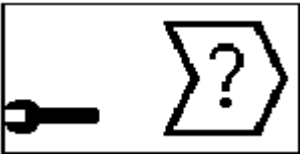
MALFUNCTION	TEST OR INSPECTION	CORRECTIVE ACTION
<p>Error Code 344 - Both Steering Wheel Signals are Interrupted.</p> 	<p>Perform troubleshooting procedure for error code 341 (WP 0033 00).</p>	

Table 15. Error Code 347 - No Steering Mode Selected Troubleshooting Procedures.

MALFUNCTION	TEST OR INSPECTION	CORRECTIVE ACTION
<p>Error Code 347 - No Steering Mode Selected.</p> 		<p>Select a steering mode (TM 10-3930-675-10).</p>

END OF WORK PACKAGE

THIS WORK PACKAGE COVERS

Error Code 317 - Right-Front Wheel Angle Cannot Reach Set Point Value

Error Code 318 - Right-Rear Wheel Angle Cannot Reach Set Point Value

Error Code 319 - Left-Rear Wheel Angle Cannot Reach Set Point Value

Error Code 320 - Left-Front Wheel Angle Cannot Reach Set Point Value

Error Code 321 - Right-Front Wheel is Not Calibrated Correctly

Error Code 322 - Right-Rear Wheel is Not Calibrated Correctly

Error Code 323 - Left-Rear Wheel is Not Calibrated Correctly

Error Code 324 - Left-Front Wheel is Not Calibrated Correctly

INITIAL SETUP

References

TM 10-3930-675-10

NOTE

Refer to WP 0004 00 for additional troubleshooting guidance, information, and illustrations that locate critical components.

Table 1. Error Code 317 - Right-Front Wheel Angle Cannot Reach Set Point Value Troubleshooting Procedures.


MALFUNCTION	TEST OR INSPECTION	CORRECTIVE ACTION
<p>Error Code 317 - Right-Front Wheel Angle Cannot Reach Set Point Value.</p> 	<ol style="list-style-type: none"> 1. Check for obstructions that will not allow the wheel to move through the full steering range. 2. Check condition of steering cylinders. 3. Check hydraulic pressure at test points no. 3, 6, and 7 (WP 0188 00). Pressure should be 3,045 psi (210 bar). <p style="text-align: center;">NOTE</p> <p>Operating the vehicle with a load and steering to extremes when not rolling on rough pavement type surfaces may cause error code 317.</p>	<ol style="list-style-type: none"> a. Remove any obstructions. b. Lubricate (GAA) the axle steering knuckle pins (WP 0050 00). c. Check operating surface conditions for excessive tire friction or obstruction. <p>Replace damaged or leaking steering cylinder (WP 0135 00).</p> <p>If pressure is not as specified, adjust steering pump pressure (WP 0243 00) or replace steering pump (WP 0242 00).</p>

Table 2. Error Code 318 - Right-Rear Wheel Angle Cannot Reach Set Point Value Troubleshooting Procedures.


MALFUNCTION	TEST OR INSPECTION	CORRECTIVE ACTION
<p>Error Code 318 - Right-Rear Wheel Angle Cannot Reach Set Point Value.</p> 	<ol style="list-style-type: none"> 1. Check for obstructions that will not allow the wheel to move through the full steering range. 2. Check condition of steering cylinders. 3. Check hydraulic pressure at test points no. 3, 6, and 7 (WP 0188 00). Pressure should be 3,045 psi (210 bar). <p style="text-align: center;">NOTE</p> <p>Operating the vehicle with a load and steering to extremes when not rolling on rough pavement type surfaces may cause error code 318.</p>	<ol style="list-style-type: none"> a. Remove any obstructions. b. Lubricate (GAA) the axle steering knuckle pins (WP 0050 00). c. Check operating surface conditions for excessive tire friction or obstruction. <p>Replace damaged or leaking steering cylinder (WP 0135 00).</p> <p>If pressure is not as specified, adjust steering pump pressure (WP 0243 00) or replace steering pump (WP 0242 00).</p>

Table 3. Error Code 319 - Left-Rear Wheel Angle Cannot Reach Set Point Value Troubleshooting Procedures.


MALFUNCTION	TEST OR INSPECTION	CORRECTIVE ACTION
<p>Error Code 319 - Left-Rear Wheel Angle Cannot Reach Set Point Value.</p> 	<ol style="list-style-type: none"> 1. Check for obstructions that will not allow the wheel to move through the full steering range. 2. Check condition of steering cylinders. 3. Check hydraulic pressure at test points no. 3, 6, and 7 (WP 0188 00). Pressure should be 3,045 psi (210 bar). <p style="text-align: center;">NOTE</p> <p>Operating the vehicle with a load and steering to extremes when not rolling on rough pavement type surfaces may cause error code 319.</p>	<ol style="list-style-type: none"> a. Remove any obstructions. b. Lubricate (GAA) the axle steering knuckle pins (WP 0050 00). c. Check operating surface conditions for excessive tire friction or obstructions. <p>Replace damaged or leaking steering cylinder (WP 0135 00).</p> <p>If pressure is not as specified, adjust steering pump pressure (WP 0243 00) or replace steering pump (WP 0242 00).</p>

Table 4. Error Code 320 - Left-Front Wheel Angle Cannot Reach Set Point Value Troubleshooting Procedures.


MALFUNCTION	TEST OR INSPECTION	CORRECTIVE ACTION
<p data-bbox="160 409 716 472">Error Code 320 - Left-Front Wheel Angle Cannot Reach Set Point Value.</p> 	<ol style="list-style-type: none"> <li data-bbox="735 409 1088 535">1. Check for obstructions that will not allow the wheel to move through the full steering range. <li data-bbox="735 661 1088 724">2. Check condition of steering cylinders. <li data-bbox="735 745 1088 871">3. Check hydraulic pressure at test points no. 3, 6, and 7 (WP 0188 00). Pressure should be 3,045 psi (210 bar). <p data-bbox="1047 882 1144 913" style="text-align: center;">NOTE</p> <p data-bbox="779 934 1412 1029">Operating the vehicle with a load and steering to extremes when not rolling on rough pavement type surfaces may cause error code 320.</p>	<ol style="list-style-type: none"> <li data-bbox="1107 409 1421 441">a. Remove any obstructions. <li data-bbox="1107 451 1421 546">b. Lubricate (GAA) the axle steering knuckle pins (WP 0050 00). <li data-bbox="1107 556 1421 651">c. Check operating surface conditions for excessive tire friction or obstruction. <p data-bbox="1107 661 1453 724">Replace damaged or leaking steering cylinder (WP 0135 00).</p> <p data-bbox="1107 745 1453 871">If pressure is not as specified, adjust steering pump pressure (WP 0243 00) or replace steering pump (WP 0242 00).</p>

Table 5. Error Code 321 - Right-Front Wheel is Not Calibrated Correctly Troubleshooting Procedures.


MALFUNCTION	TEST OR INSPECTION	CORRECTIVE ACTION
<p data-bbox="160 1192 716 1255">Error Code 321 - Right-Front Wheel is Not Calibrated Correctly.</p> 		<p data-bbox="1107 1192 1453 1224">Calibrate steering (WP 0238 00).</p>

Table 6. Error Code 322 - Right-Rear Wheel is Not Calibrated Correctly Troubleshooting Procedures.


MALFUNCTION	TEST OR INSPECTION	CORRECTIVE ACTION
<p data-bbox="160 1598 716 1661">Error Code 322 - Right-Rear Wheel is Not Calibrated Correctly.</p> 		<p data-bbox="1107 1598 1453 1629">Calibrate steering (WP 0238 00).</p>

Table 7. Error Code 323 - Left-Rear Wheel is Not Calibrated Correctly Troubleshooting Procedures.



MALFUNCTION	TEST OR INSPECTION	CORRECTIVE ACTION
<p>Error Code 323 - Left-Rear Wheel is Not Calibrated Correctly.</p> 		<p>Calibrate steering (WP 0238 00).</p>

Table 8. Error Code 324 - Left-Front Wheel is Not Calibrated Correctly Troubleshooting Procedures.

MALFUNCTION	TEST OR INSPECTION	CORRECTIVE ACTION
<p>Error Code 324 - Left-Front Wheel is Not Calibrated Correctly.</p> 		<p>Calibrate steering (WP 0238 00).</p>

END OF WORK PACKAGE

STEERING SENSOR TROUBLESHOOTING**0035 00**

THIS WORK PACKAGE COVERS

Error Code 301 - Right-Front Wheel Sensor Circuit Failure

Error Code 302 - Right-Rear Wheel Sensor Circuit Failure

Error Code 303 - Left-Rear Wheel Sensor Circuit Failure

Error Code 304 - Left-Front Wheel Sensor Circuit Failure

Error Code 305 - Right-Front Wheel Sensor Circuit Failure

Error Code 306 - Right-Rear Wheel Sensor Circuit Failure

Error Code 307 - Left-Rear Wheel Sensor Circuit Failure

Error Code 308 - Left-Front Wheel Sensor Circuit Failure

Error Code 309 - Right-Front Wheel Sensor Circuit Failure

Error Code 310 - Right-Rear Wheel Sensor Circuit Failure

Error Code 311 - Left-Rear Wheel Sensor Circuit Failure

Error Code 312 - Left-Front Wheel Sensor Circuit Failure

Error Code 313 - Right-Front Wheel Sensor Circuit Failure

Error Code 314 - Right-Rear Wheel Sensor Circuit Failure

Error Code 315 - Left-Rear Wheel Sensor Circuit Failure

Error Code 316 - Left-Front Wheel Sensor Circuit Failure

Error Code 339 - Grounding of Steering Wheel Sensor Interrupted

INITIAL SETUP**References**

TM 10-3930-675-10

ECS Steering (A34651.0200) (WP 0048 00-16)

NOTE

Refer to WP 0004 00 for additional troubleshooting guidance, information, and illustrations that locate critical components.

Table 1. Error Code 301 - Right-Front Wheel Sensor Circuit Failure Troubleshooting Procedures.


MALFUNCTION	TEST OR INSPECTION	CORRECTIVE ACTION
<p data-bbox="159 409 719 468">Error Code 301 - Right-Front Wheel Sensor Circuit Failure.</p> 	<ol style="list-style-type: none"> <li data-bbox="735 409 1091 468">1. Check right-front wheel sensor and wire for damage. <li data-bbox="735 489 1091 646">2. Test signal. Enter DIAG STEERING 8(16) in the diagnostic menu. Observe if signal 1 changes when steering in both directions. <li data-bbox="735 667 1091 947">3. Check resistance. Remove the engine cover to access X167. Disconnect wires 1, 2, and 3 from pins 1, 2, and 3 (WP 0048 00-20). Check resistance between wires 1 and 3. Should be around 2k Ohms. Check resistance between wires 1 and 2. Should be 2k to 4k Ohms. <li data-bbox="735 968 1091 1188">4. Inspect X167 wiring and terminals for damage. Inspect connector X171 for damage. Check resistance of wires GY, BK, and RD between X167 pins 1, 2, and 3 and X171 pins 1, 2, and 3 (WP 0048 00-20). <li data-bbox="735 1209 1091 1360">5. Inspect ECU (792) pins 37, 86, and 90 for connection or damage. Check continuity of wires A1711, A1712, and A1713 (WP 0048 00-20). 	<p data-bbox="1107 409 1461 468">Replace sensor if damaged (WP 0104 00).</p> <p data-bbox="1107 489 1461 611">If signal 1 is around ± 70 and does not change, this indicates a break in the circuit or in the wheel sensor. Continue with step 3.</p> <p data-bbox="1107 667 1461 821">If resistance is not as specified, replace right-front wheel sensor (WP 0104 00). Reconnect wheel sensor wires 1, 2, and 3 after checking.</p> <ol style="list-style-type: none"> <li data-bbox="1107 968 1461 1089">a. If continuity is not found at any one wire, notify Sustainment Maintenance to replace X171 to X167 harness. <li data-bbox="1107 1094 1461 1152">b. Repair or replace damaged connectors (WP 0113 00). <li data-bbox="1107 1209 1461 1268">a. Replace damaged ECU (792) terminal board (WP 0080 00). <li data-bbox="1107 1272 1461 1360">b. Repair or replace damaged wires or connectors (WP 0113 00). <li data-bbox="1107 1365 1461 1423">c. Replace right-front wheel sensor (WP 0104 00).

Table 2. Error Code 302 - Right-Rear Wheel Sensor Circuit Failure Troubleshooting Procedures.


MALFUNCTION	TEST OR INSPECTION	CORRECTIVE ACTION
<p data-bbox="147 401 724 464">Error Code 302 - Right-Rear Wheel Sensor Circuit Failure.</p> 	<ol style="list-style-type: none"> <li data-bbox="724 401 1094 464">1. Check right-rear wheel sensor and wire for damage. <li data-bbox="724 657 1094 810">2. Check resistance. Enter DIAG STEERING 9(16) in the diagnostic menu. Observe if signal 1 changes when steering in both directions. <li data-bbox="724 835 1094 1108">3. Disconnect wires 1, 2, and 3 from X192 pins 1, 2, and 3 (WP 0048 00-21). Check resistance between wires 1 and 3. Resistance should be around 2k Ohms. Check resistance between wires 1 and 2. Resistance should be 2k to 4k Ohms. <li data-bbox="724 1134 1094 1350">4. Inspect X192 wiring and terminals for damage. Inspect connector X170 for damage. Check resistance of wires GY, BK, and RD between X192 pins 1, 2, and 3 and X170 pins 1, 2, and 3 (WP 0048 00-21). <li data-bbox="724 1375 1094 1528">5. Inspect ECU (792) pins 36, 87, and 92 for connection or damage. Check continuity of wires A1701, A1702, and A1703 (WP 0048 00-21). 	<p data-bbox="1094 401 1471 464">Replace sensor if damaged (WP 0104 00).</p> <p data-bbox="1094 657 1471 779">If signal 1 is around ± 70 and does not change, this indicates a break in the circuit or in the wheel sensor. Continue with step 3.</p> <p data-bbox="1094 835 1471 982">If resistance is not as specified, replace right-rear wheel sensor (WP 0104 00). Reconnect wheel sensor wires 1, 2, and 3 after checking.</p> <ol style="list-style-type: none"> <li data-bbox="1094 1134 1471 1255">a. If continuity is not found at any one wire, notify Sustainment Maintenance to replace X170 to X192 harness. <li data-bbox="1094 1260 1471 1318">b. Repair or replace damaged connectors (WP 0113 00). <ol style="list-style-type: none"> <li data-bbox="1094 1375 1471 1434">a. Replace damaged ECU (792) terminal board (WP 0080 00). <li data-bbox="1094 1438 1471 1528">b. Repair or replace damaged wires or connectors (WP 0113 00). <li data-bbox="1094 1533 1471 1591">c. Replace right-rear wheel sensor (WP 0104 00).

Table 3. Error Code 303 - Left-Rear Wheel Sensor Circuit Failure Troubleshooting Procedures.


MALFUNCTION	TEST OR INSPECTION	CORRECTIVE ACTION
<p>Error Code 303 - Left-Rear Wheel Sensor Circuit Failure.</p> 	<ol style="list-style-type: none"> 1. Check left-rear wheel sensor and wire for damage. 2. Enter DIAG STEERING 10(16) in the diagnostic menu. Observe if signal 1 changes when steering in both directions. 3. Check resistance. Disconnect wires 1, 2, and 3 from X192 pins 8, 9, and 10 (WP 0048 00-21). Check resistance between wires 1 and 3. Resistance should be around 2k Ohms. Check resistance between wires 1 and 2. Resistance should be 2k to 4k Ohms. 4. Inspect X192 wiring and terminals for damage. Inspect connector X170 for damage. Check resistance of wires BN, WH, and VT between X192 pins 8, 9, and 10 and X170 pins 9, 10, and 11 (WP 0048 00-21). 5. Inspect ECU (792) pins 35, 88, and 94 for connection or damage. Check continuity of wires A1709, A17010, A17011A, and A17011B (WP 0048 00-21). 	<p>Replace sensor if damaged (WP 0104 00).</p> <p>If signal 1 is around ± 70 and does not change, this indicates a break in the circuit or in the wheel sensor. Continue with step 3.</p> <p>If resistance is not as specified, replace left-rear wheel sensor (WP 0104 00). Reconnect wheel sensor wires 1, 2, and 3 after checking.</p> <ol style="list-style-type: none"> a. If continuity is not found at any one wire, notify Sustainment Maintenance to replace X170 and X192 harness. b. Repair or replace damaged connectors (WP 0113 00). a. Replace damaged ECU (792) terminal board (WP 0080 00). b. Repair or replace damaged wires or connectors (WP 0113 00). c. Replace left-rear wheel sensor (WP 0104 00).

Table 4. Error Code 304 - Left-Front Wheel Sensor Circuit Failure Troubleshooting Procedures.


MALFUNCTION	TEST OR INSPECTION	CORRECTIVE ACTION
<p data-bbox="159 407 717 464">Error Code 304 - Left-Front Wheel Sensor Circuit Failure.</p> 	<ol style="list-style-type: none"> <li data-bbox="735 407 1089 464">1. Check left-front wheel sensor and wire for damage. <li data-bbox="735 485 1089 646">2. Test signal. Enter DIAG STEERING 11(16) in the diagnostic menu. Observe if signal 1 changes when steering in both directions. <li data-bbox="735 667 1089 1003">3. Check resistance. Remove the engine cover to access X167. Disconnect wires 1, 2, and 3 from pins 8, 9, and 10 (WP 0048 00-20). Check resistance between wires 1 and 3. Resistance should be around 2k Ohms. Check resistance between wires 1 and 2. Resistance should be 2k to 4k Ohms. <li data-bbox="735 1024 1089 1245">4. Inspect X167 wiring and terminals for damage. Inspect connector X171 for damage. Check resistance of wires BN, WH, and VT between X167 pins 8, 9, and 10 and X171 pins 9, 10, and 11 (WP 0048 00-20). <li data-bbox="735 1266 1089 1455">5. Inspect ECU (792) pins 34, 89, and 95 for connection or damage. Check continuity of wires A1719, A17110, A17111A, and A17111B (WP 0048 00-20). 	<p data-bbox="1105 407 1459 464">Replace sensor if damaged (WP 0104 00).</p> <p data-bbox="1105 485 1459 611">If signal 1 is around ± 70 and does not change, this indicates a break in the circuit or in the wheel sensor. Continue with step 3.</p> <p data-bbox="1105 653 1459 800">If resistance is not as specified, replace left-front wheel sensor (WP 0104 00). Reconnect wheel sensor wires 1, 2, and 3 after checking.</p> <ol style="list-style-type: none"> <li data-bbox="1105 1024 1459 1150">a. If continuity is not found at any one wire, notify Sustainment Maintenance to replace X171 to X167 harness. <li data-bbox="1105 1150 1459 1213">b. Repair or replace damaged connectors (WP 0113 00). <li data-bbox="1105 1266 1459 1329">a. Replace damaged ECU (792) terminal board (WP 0080 00). <li data-bbox="1105 1329 1459 1413">b. Repair or replace damaged wires or connectors (WP 0113 00). <li data-bbox="1105 1413 1459 1476">c. Replace left-front wheel sensor (WP 0104 00).

Table 5. Error Code 305 - Right-Front Wheel Sensor Circuit Failure Troubleshooting Procedures.


MALFUNCTION	TEST OR INSPECTION	CORRECTIVE ACTION
<p data-bbox="159 411 717 468">Error Code 305 - Right-Front Wheel Sensor Circuit Failure.</p> 	<ol style="list-style-type: none"> <li data-bbox="732 411 1089 468">1. Check right-front wheel sensor and wire for damage. <li data-bbox="732 489 1089 642">2. Test signal. Enter DIAG STEERING 8(16) in the diagnostic menu. Observe if signal 2 changes when steering in both directions. <li data-bbox="732 663 1089 1010">3. Check resistance. Remove the engine cover to access X167. Disconnect wires 4, 5, and YE/ GN from pins 4, 5, and 6 (WP 0048 00-20). Check resistance between wires 4 and YE/ GN. Resistance should be around 2k Ohms. Check resistance between wires 4 and 5. Resistance should be 2k to 4k Ohms. <li data-bbox="732 1031 1089 1251">4. Inspect X167 wiring and terminals for damage. Inspect connector X171 for damage. Check resistance of wires BU, YE, and GN between X167 pins 4, 5, and 6 and X171 pins 4, 5, and 6 (WP 0048 00-20). <li data-bbox="732 1272 1089 1425">5. Inspect ECU (792) pins 33, 91, and 138 for connection or damage. Check continuity of wires A1714, A1715, and A1716 (WP 0048 00-20). 	<p data-bbox="1101 411 1458 468">Replace sensor if damaged (WP 0104 00).</p> <p data-bbox="1101 489 1458 611">If signal 2 is around ± 70 and does not change, this indicates a break in the circuit or in the wheel sensor. Continue with step 3.</p> <p data-bbox="1101 663 1458 821">If resistance is not as specified, replace right-front wheel sensor (WP 0104 00). Reconnect wheel sensor wires 4, 5, and YE/ GN after checking.</p> <ol style="list-style-type: none"> <li data-bbox="1101 1031 1458 1152">a. If continuity is not found at any one wire, notify Sustainment Maintenance to replace X171 to X167 harness. <li data-bbox="1101 1152 1458 1209">b. Repair or replace damaged connectors (WP 0113 00). <li data-bbox="1101 1272 1458 1329">a. Replace damaged ECU (792) terminal board (WP 0080 00). <li data-bbox="1101 1329 1458 1430">b. Repair or replace damaged wires or connectors (WP 0113 00). <li data-bbox="1101 1430 1458 1486">c. Replace right-front wheel sensor (WP 0104 00).

Table 6. Error Code 306 - Right-Rear Wheel Sensor Circuit Failure Troubleshooting Procedures.


MALFUNCTION	TEST OR INSPECTION	CORRECTIVE ACTION
<p data-bbox="159 401 719 457">Error Code 306 - Right-Rear Wheel Sensor Circuit Failure.</p> 	<ol style="list-style-type: none"> <li data-bbox="732 401 1088 464">1. Check right-rear wheel sensor and wire for damage. <li data-bbox="732 478 1088 636">2. Check signal. Enter DIAG STEERING 9(16) in the diagnostic menu. Observe if signal 2 changes when steering in both directions. <li data-bbox="732 653 1088 968">3. Check resistance. Disconnect wires 4, 5, and YE/GN from X192 pins 4, 5, and 6 (WP 0048 00-21). Check resistance between wires 4 and YE/GN. Resistance should be around 2k Ohms. Check resistance between wires 4 and 5. Resistance should be 2k to 4k Ohms. <li data-bbox="732 989 1088 1209">4. Inspect X192 wiring and terminals for damage. Inspect connector X170 for damage. Check resistance of wires BU, YE, and GN between X192 pins 4, 5, and 6 and X170 pins 4, 5, and 6 (WP 0048 00-21). <li data-bbox="732 1230 1088 1381">5. Inspect ECU (792) pins 32, 93, and 139 for connection or damage. Check continuity of wires A1704, A1705, and A1706 (WP 0048 00-21). 	<p data-bbox="1104 401 1456 464">Replace sensor if damaged (WP 0104 00).</p> <p data-bbox="1104 478 1456 604">If signal 2 is around ± 70 and does not change, this indicates a break in the circuit or in the wheel sensor. Continue with step 3.</p> <p data-bbox="1104 653 1456 810">If resistance is not as specified, replace right-rear wheel sensor (WP 0104 00). Reconnect wheel sensor wires 4, 5, and YE/GN after checking.</p> <ol style="list-style-type: none"> <li data-bbox="1104 989 1456 1146">a. If continuity is not found at any one wire, notify Sustainment Maintenance to replace X170 and X192 harness. <li data-bbox="1104 1146 1456 1209">b. Repair or replace damaged connectors (WP 0113 00). <li data-bbox="1104 1230 1456 1293">a. Replace damaged ECU (792) terminal board (WP 0080 00). <li data-bbox="1104 1293 1456 1381">b. Repair or replace damaged wires or connectors (WP 0113 00). <li data-bbox="1104 1381 1456 1444">c. Replace right-rear wheel sensor (WP 0104 00).

Table 7. Error Code 307 - Left-Rear Wheel Sensor Circuit Failure Troubleshooting Procedures.


MALFUNCTION	TEST OR INSPECTION	CORRECTIVE ACTION
<p data-bbox="159 401 717 457">Error Code 307 - Left-Rear Wheel Sensor Circuit Failure.</p> 	<ol style="list-style-type: none"> <li data-bbox="732 401 1089 464">1. Check left-rear wheel sensor and wire for damage. <li data-bbox="732 478 1089 636">2. Check signal. Enter DIAG STEERING 10(16) in the diagnostic menu. Observe if signal 2 changes when steering in both directions. <li data-bbox="732 651 1089 968">3. Check resistance. Disconnect wires 4, 5, and YE/GN from X192 pins 11, 12, and 13 (WP 0048 00-21). Check resistance between wires 4 and YE/GN. Resistance should be around 2k Ohms. Check resistance between wires 4 and 5. Resistance should be 2k to 4k Ohms. <li data-bbox="732 982 1089 1241">4. Inspect X192 wiring and terminals for damage. Inspect connector X170 for damage. Check resistance of wires OR, WH/BK, and WH/RD between X192 pins 11, 12, and 13 and X170 pins 12, 13, and 14 (WP 0048 00-21). <li data-bbox="732 1255 1089 1413">5. Inspect ECU (792) pins 31, 94, and 140 for connection or damage. Check continuity of wires A17012, A17013, and A17011B (WP 0048 00-21). 	<p data-bbox="1105 401 1458 464">Replace sensor if damaged (WP 0104 00).</p> <p data-bbox="1105 478 1458 604">If signal 2 is around ± 70 and does not change, this indicates a break in the circuit or in the wheel sensor. Continue with step 3.</p> <p data-bbox="1105 651 1458 808">If resistance is not as specified, replace left-rear wheel sensor (WP 0104 00). Reconnect wheel sensor wires 4, 5, and YE/GN after checking.</p> <ol style="list-style-type: none"> <li data-bbox="1105 982 1458 1108">a. If continuity is not found at any one wire, notify Sustainment Maintenance to replace X170 to X192 harness. <li data-bbox="1105 1115 1458 1178">b. Repair or replace damaged connectors (WP 0113 00). <li data-bbox="1105 1255 1458 1318">a. Replace damaged ECU (792) terminal board (WP 0080 00). <li data-bbox="1105 1325 1458 1409">b. Repair or replace damaged wires or connectors (WP 0113 00). <li data-bbox="1105 1415 1458 1478">c. Replace left-rear wheel sensor (WP 0104 00).

Table 8. Error Code 308 - Left-Front Wheel Sensor Circuit Failure Troubleshooting Procedures.


MALFUNCTION	TEST OR INSPECTION	CORRECTIVE ACTION
<p data-bbox="159 401 719 457">Error Code 308 - Left-Front Wheel Sensor Circuit Failure.</p> 	<ol style="list-style-type: none"> <li data-bbox="732 401 1088 457">1. Check left-front wheel sensor and wire for damage. <li data-bbox="732 478 1088 632">2. Check signal. Enter DIAG STEERING 11(16) in the diagnostic menu. Observe if signal 2 changes when steering in both directions. <li data-bbox="732 653 1088 995">3. Check resistance. Remove the engine cover to access X167. Disconnect wires 4, 5, and YE/GN from pins 11, 12, and 13 (WP 0048 00-20). Check resistance between wires 4 and YE/GN. Resistance should be around 2k Ohms. Check resistance between wires 4 and 5. Resistance should be 2k to 4k Ohms. <li data-bbox="732 1016 1088 1268">4. Inspect X167 wiring and terminals for damage. Inspect connector X171 for damage. Check resistance of wires OR, WH/BK and WH/RD between X167 pins 11, 12, and 13 and X171 pins 12, 13, and 14 (WP 0048 00-20). <li data-bbox="732 1289 1088 1442">5. Inspect ECU (792) pins 30, 95, and 141 for connection or damage. Check continuity of wires A17112, A17113, and A17111B (WP 0048 00-20). 	<p data-bbox="1104 401 1458 457">Replace sensor if damaged (WP 0104 00).</p> <p data-bbox="1104 478 1458 600">If signal 2 is around ± 70 and does not change, this indicates a break in the circuit or in the wheel sensor. Continue with step 3.</p> <p data-bbox="1104 653 1458 806">If resistance is not as specified, replace left-front wheel sensor (WP 0104 00). Reconnect wheel sensor wires 4, 5, and YE/GN after checking.</p> <ol style="list-style-type: none"> <li data-bbox="1104 1016 1458 1138">a. If continuity is not found at any one wire, notify Sustainment Maintenance to replace X171 to X167 harness. <li data-bbox="1104 1138 1458 1205">b. Repair or replace damaged connectors (WP 0113 00). <li data-bbox="1104 1289 1458 1356">a. Replace damaged ECU (792) terminal board (WP 0080 00). <li data-bbox="1104 1356 1458 1442">b. Repair or replace damaged wires or connectors (WP 0113 00). <li data-bbox="1104 1442 1458 1509">c. Replace left-front wheel sensor (WP 0104 00).

Table 9. Error Code 309 - Right-Front Wheel Sensor Circuit Failure Troubleshooting Procedures.


MALFUNCTION	TEST OR INSPECTION	CORRECTIVE ACTION
<p data-bbox="159 373 717 430">Error Code 309 - Right-Front Wheel Sensor Circuit Failure.</p> 	<p data-bbox="1047 373 1144 405" style="text-align: center;">NOTE</p> <p data-bbox="779 420 1412 483">Error codes 301 and 305 may be activated with error code 309.</p> <ol style="list-style-type: none"> <li data-bbox="730 598 1088 661">1. Check right-front wheel sensor and wire for damage. <li data-bbox="730 682 1088 829">2. Check signal. Enter DIAG STEERING 8(16) in the diagnostic menu. Observe if signals 1 and 2 change when steering in both directions. <li data-bbox="730 850 1088 1197">3. Check resistance. Remove the engine cover to access X167. Disconnect wires 1, 2, and 3 from pins 1, 2, and 3 (WP 0048 00-20). Check resistance between wires 1 and 3. Resistance should be around 2k Ohms. Check resistance between wires 1 and 2. Resistance should be 2k to 4k Ohms. <li data-bbox="730 1218 1088 1533">4. Check resistance. Disconnect wires 4, 5, and YE/GN from X167 pins 4, 5, and 6 (WP 0048 00-20). Check resistance between wires 4 and YE/GN. Resistance should be around 2k Ohms. Check resistance between wires 4 and 5. Resistance should be 2k to 4k Ohms. <li data-bbox="730 1554 1088 1774">5. Inspect X167 wiring and terminals for damage. Inspect connector X171 for damage. Check resistance of wires GY, BK, and RD between X167 pins 1, 2, and 3 and X171 pins 1, 2, and 3 (WP 0048 00-20). 	<p data-bbox="1104 598 1453 661">Replace sensor if damaged (WP 0104 00).</p> <p data-bbox="1104 682 1453 829">If signals 1 and 2 are around ± 70 and do not change, this indicates a break in the circuit or in the wheel sensor. Continue with step 3.</p> <p data-bbox="1104 850 1453 1008">If resistance is not as specified, replace right-front wheel sensor (WP 0104 00). Reconnect wheel sensor wires 1, 2, and 3 after checking.</p> <p data-bbox="1104 1218 1453 1375">If resistance is not as specified, replace right-front wheel sensor (WP 0104 00). Reconnect wheel sensor wires 4, 5, and YE/GN after checking.</p> <ol style="list-style-type: none"> <li data-bbox="1104 1554 1453 1669">a. If continuity is not found at any one wire, notify Sustainment Maintenance to replace X171 to X167 harness. <li data-bbox="1104 1680 1453 1743">b. Repair or replace damaged connectors (WP 0113 00).

Table 9. Error Code 309 - Right-Front Wheel Sensor Circuit Failure Troubleshooting Procedures - Continued.

MALFUNCTION	TEST OR INSPECTION	CORRECTIVE ACTION
Error Code 309 - Right-Front Wheel Sensor Circuit Failure - Continued.	6. Check resistance of wires BU, YE, and GN between X167 pins 4, 5, and 6 and X171 pins 4, 5, and 6 (WP 0048 00-20). 7. Inspect ECU (792) pins 37, 86, and 90 for connection or damage. Check continuity of wires A1711, A1712, and A1713 (WP 0048 00-20). 8. Inspect ECU (792) pins 33, 91, and 138 for connection or damage. Check continuity of wires A1714, A1715, and A1716 (WP 0048 00-20).	a. If continuity is not found at any one wire, notify Sustainment Maintenance to replace X171 to X167 harness. b. Repair or replace damaged connectors (WP 0113 00). a. Replace damaged ECU (792) terminal board (WP 0080 00). b. Repair or replace damaged wires or connectors (WP 0113 00). a. Replace damaged ECU (792) terminal board (WP 0080 00). b. Repair or replace damaged wires or connectors (WP 0113 00). c. Replace right-front wheel sensor (WP 0104 00).

Table 10. Error Code 310 - Right-Rear Wheel Sensor Circuit Failure Troubleshooting Procedures.



MALFUNCTION	TEST OR INSPECTION	CORRECTIVE ACTION
Error Code 310 - Right-Rear Wheel Sensor Circuit Failure. 	<p style="text-align: center;">NOTE</p> <p>Error codes 302 and 306 may be activated with error code 310.</p> 1. Check right-rear wheel sensor and wire for damage. 2. Check signal. Enter DIAG STEERING 9(16) in the diagnostic menu. Observe if signals 1 and 2 change when steering in both directions.	Replace sensor if damaged (WP 0104 00). If signals 1 and 2 are around ± 70 and does not change, this indicates a break in the circuit or in the wheel sensor. Continue with step 3.

Table 10. Error Code 310 - Right-Rear Wheel Sensor Circuit Failure Troubleshooting Procedures - Continued.

MALFUNCTION	TEST OR INSPECTION	CORRECTIVE ACTION
<p>Error Code 310 - Right-Rear Wheel Sensor Circuit Failure - Continued.</p>	<p>3. Disconnect wires 1, 2, and 3 from X192 pins 1, 2, and 3 (WP 0048 00-21). Check resistance between wires 1 and 3. Resistance should be around 2k Ohms. Check resistance between wires 1 and 2. Resistance should be 2k to 4k Ohms.</p> <p>4. Disconnect wires 4, 5, and YE/GN from X192 pins 4, 5, and 6 (WP 0048 00-21). Check resistance between wires 4 and YE/GN. Resistance should be around 2k Ohms. Check resistance between wires 4 and 5. Resistance should be 2k to 4k Ohms.</p> <p>5. Inspect X192 wiring and terminals for damage. Inspect connector X170 for damage. Check resistance of wires GY, BK, and RD between X192 pins 1, 2, and 3 and X170 pins 1, 2, and 3 (WP 0048 00-21).</p> <p>6. Check resistance of wires BU, YE, and GN between X192 pins 4, 5, and 6 X170 pins 4, 5, and 6 (WP 0048 00-21).</p> <p>7. Inspect ECU (792) pins 36, 87, and, 92 for connection or damage. Check continuity of wires A1701, A1702, and A1703 (WP 0048 00-21).</p> <p>8. Inspect ECU (792) pins 32, 93, and 139 for connection or damage. Check continuity of wires A1704, A1705, and A1706 (WP 0048 00-21).</p>	<p>If resistance is not as specified, replace right-rear wheel sensor (WP 0104 00). Reconnect wheel sensor wires 1, 2, and 3 after checking.</p> <p>If resistance is not as specified, replace right-rear wheel sensor (WP 0104 00). Reconnect wheel sensor wires 4, 5, and YE/GN after checking.</p> <p>a. If continuity is not found at any one wire, notify Sustainment Maintenance to replace X170 to X192 harness. b. Repair or replace damaged connectors (WP 0113 00).</p> <p>a. If continuity is not found at any one wire, notify Sustainment Maintenance to replace X170 to X192 harness. b. Repair or replace damaged connectors (WP 0113 00).</p> <p>a. Replace damaged ECU (792) terminal board (WP 0080 00). b. Repair or replace damaged wires or connectors (WP 0113 00).</p> <p>a. Replace damaged ECU (792) terminal board (WP 0080 00). b. Repair or replace damaged wires or connectors (WP 0113 00). c. Replace right-rear wheel sensor (WP 0104 00).</p>

Table 11. Error Code 311 - Left-Rear Wheel Sensor Circuit Failure Troubleshooting Procedures.

MALFUNCTION	TEST or INSPECTION	CORRECTIVE ACTION
<p data-bbox="159 401 717 457">Error Code 311 - Left-Rear Wheel Sensor Circuit Failure.</p> 	<p data-bbox="1047 401 1144 432" style="text-align: center;">NOTE</p> <p data-bbox="781 449 1414 506">Error codes 303 and 307 may be activated with error code 311.</p> <ol style="list-style-type: none"> <li data-bbox="735 653 1089 709">1. Check left-rear wheel sensor and wire for damage. <li data-bbox="735 732 1089 888">2. Check signal. Enter DIAG STEERING 10(16) in the diagnostic menu. Observe if signals 1 and 2 change when steering in both directions. <li data-bbox="735 911 1089 1188">3. Disconnect wires 1, 2, and 3 from X192 pins 8, 9, and 10 (WP 0048 00-21). Check resistance between wires 1 and 3. Resistance should be around 2k Ohms. Check resistance between wires 1 and 2. Resistance should be 2k to 4k Ohms. <li data-bbox="735 1211 1089 1488">4. Disconnect wires 4, 5, and YE/GN from X192 pins 11, 12, and 13 (WP 0048 00-21). Check resistance between wires 4 and YE/GN. Resistance should be around 2k Ohms. Check resistance between wires 4 and 5. Resistance should be 2k to 4k Ohms. <li data-bbox="735 1512 1089 1730">5. Inspect X192 wiring and terminals for damage. Inspect connector X170 for damage. Check resistance of wires BN, WH, and VT between X192 pins 8, 9, and 10 and X170 pins 9, 10, and 11 (WP 0048 00-21). 	<p data-bbox="1105 653 1458 709">Replace sensor if damaged (WP 0104 00).</p> <p data-bbox="1105 732 1458 888">If signals 1 and 2 are around ± 70 and do not change, this indicates a break in the circuit or in the wheel sensor. Continue with step 3.</p> <p data-bbox="1105 911 1458 1066">If resistance is not as specified, replace left-rear wheel sensor (WP 0104 00). Reconnect wheel sensor wires 1, 2, and 3 after checking.</p> <p data-bbox="1105 1211 1458 1367">If resistance is not as specified, replace left-rear wheel sensor (WP 0104 00). Reconnect wheel sensor wires 4, 5, and YE/GN after checking.</p> <ol style="list-style-type: none"> <li data-bbox="1105 1512 1458 1633">a. If continuity is not found at any one wire, notify Sustainment Maintenance to replace X170 to X192 harness. <li data-bbox="1105 1640 1458 1696">b. Repair or replace damaged connectors (WP 0113 00).

STEERING SENSOR TROUBLESHOOTING - CONTINUED

0035 00

Table 11. Error Code 311 - Left-Rear Wheel Sensor Circuit Failure Troubleshooting Procedures - Continued.

MALFUNCTION	TEST or INSPECTION	CORRECTIVE ACTION
Error Code 311 - Left-Rear Wheel Sensor Circuit Failure - Continued.	<p>6. Check resistance of wires OR, WH/BK, and WH/RD between X192 pins 11, 12, 13, and X170 pins 12, 13, and 14 (WP 0048 00-21).</p> <p>7. Inspect ECU (792) pins 35, 88, and 94 for connection or damage. Check continuity of wires A1709, A17010, A17011B, and A17011A (WP 0048 00-21).</p> <p>8. Inspect ECU (792) pins 31, 94, and 140 for connection or damage. Check continuity of wires A17012, A17013, and A17011B (WP 0048 00-21).</p>	<p>a. If continuity is not found at any one wire, notify Sustainment Maintenance to replace X170 to X192 harness.</p> <p>b. Repair or replace damaged connectors (WP 0113 00).</p> <p>a. Replace damaged ECU (792) terminal board (WP 0080 00).</p> <p>b. Repair or replace damaged wires or connectors (WP 0113 00).</p> <p>a. Replace damaged ECU (792) terminal board (WP 0080 00).</p> <p>b. Repair or replace damaged wires or connectors (WP 0113 00).</p> <p>c. Replace left-rear wheel sensor (WP 0104 00).</p>

Table 12. Error Code 312 - Left-Front Wheel Sensor Circuit Failure Troubleshooting Procedures.


MALFUNCTION	TEST OR INSPECTION	CORRECTIVE ACTION
Error Code 312 - Left-Front Wheel Sensor Circuit Failure. 	<p style="text-align: center;">NOTE</p> <p>Error codes 304 and 308 may be activated with error code 312.</p> <p>1. Check left-front wheel sensor and wire for damage.</p> <p>2. Check signal. Enter DIAG STEERING 11(16) in the diagnostic menu. Observe if signals 1 and 2 change when steering in both directions.</p>	<p>Replace sensor if damaged (WP 0104 00).</p> <p>If signals 1 and 2 are around ± 70 and do not change, this indicates a break in the circuit or in the wheel sensor. Continue with step 3.</p>

Table 12. Error Code 312 - Left-Front Wheel Sensor Circuit Failure Troubleshooting Procedures - Continued.

MALFUNCTION	TEST OR INSPECTION	CORRECTIVE ACTION
<p>Error Code 312 - Left-Front Wheel Sensor Circuit Failure - Continued.</p>	<p>3. Remove the engine cover to access X167. Disconnect wires 1, 2, and 3 from pins 8, 9, and 10 (WP 0048 00-20). Check resistance between wires 1 and 3. Resistance should be around 2k Ohms. Check resistance between wires 1 and 2. Resistance should be 2k to 4k Ohms.</p> <p>4. Disconnect wires 4, 5, and YE/GN from X167 pins 11, 12, and 13 (WP 0048 00-20). Check resistance between wires 4 and YE/GN. Resistance should be around 2k Ohms. Check resistance between wires 4 and 5. Resistance should be 2k to 4k Ohms.</p> <p>5. Inspect X167 wiring and terminals for damage. Inspect connector X171 for damage. Check resistance of wires BN, WH, and VT between X167 pins 8, 9, and 10 and X171 pins 9, 10, and 11 (WP 0048 00-20).</p> <p>6. Check resistance of wires OR, WH/BK, and WH/RD between X167 pins 11, 12, and 13, and X171 pins 12, 13, and 14 (WP 0048 00-20).</p> <p>7. Inspect ECU (792) pins 34, 89, and 95 for connection or damage. Check continuity or wires A1719, A17110, A17111A, and A17111B (WP 0048 00-20).</p>	<p>If resistance is not as specified, replace left-front wheel sensor (WP 0104 00). Reconnect wheel sensor wires 1, 2, and 3 after checking.</p> <p>If resistance is not as specified, replace left-front wheel sensor (WP 0104 00). Reconnect wheel sensor wires 4, 5, and YE/GN after checking.</p> <p>a. If continuity is not found at any one wire, notify Sustainment Maintenance to replace X171 to X167 harness. b. Repair or replace damaged connectors (WP 0113 00).</p> <p>a. If continuity is not found at any one wire, notify Sustainment Maintenance to replace X171 to X167 harness. b. Repair or replace damaged connectors (WP 0113 00).</p> <p>a. Replace damaged ECU (792) terminal board (WP 0080 00). b. Repair or replace damaged wires or connectors (WP 0113 00).</p>

STEERING SENSOR TROUBLESHOOTING - CONTINUED

0035 00

Table 12. Error Code 312 - Left-Front Wheel Sensor Circuit Failure Troubleshooting Procedures - Continued.

MALFUNCTION	TEST OR INSPECTION	CORRECTIVE ACTION
Error Code 312 - Left-Front Wheel Sensor Circuit Failure - Continued.	8. Inspect ECU (792) pins 30, 95, and 141 for connection or damage. Check continuity or wires A17112, A17113, and A17111B (WP 0048 00-20).	a. Replace damaged ECU (792) terminal board (WP 0080 00). b. Repair or replace damaged wires or connectors (WP 0113 00). c. Replace left-front wheel sensor (WP 0104 00).

Table 13. Error Code 313 - Right-Front Wheel Sensor Circuit Failure Troubleshooting Procedures.


MALFUNCTION	TEST OR INSPECTION	CORRECTIVE ACTION
Error Code 313 - Right-Front Wheel Sensor Circuit Failure. 		NOTE Error codes 301 or 305 may be activated with error code 313. Perform troubleshooting procedure for error code 309.

Table 14. Error Code 314 - Right-Rear Wheel Sensor Circuit Failure Troubleshooting Procedures.


MALFUNCTION	TEST OR INSPECTION	CORRECTIVE ACTION
Error Code 314 - Right-Rear Wheel Sensor Circuit Failure. 		NOTE Error codes 302 or 306 may be activated with error code 314. Perform troubleshooting procedure for error code 310.

Table 15. Error Code 315 - Left-Rear Wheel Sensor Circuit Failure Troubleshooting Procedures.


MALFUNCTION	TEST OR INSPECTION	CORRECTIVE ACTION
Error Code 315 - Left-Rear Wheel Sensor Circuit Failure. 		NOTE Error codes 303 or 307 may be activated with error code 315. Perform troubleshooting procedure for error code 311.

Table 16. Error Code 316 - Left-Front Wheel Sensor Circuit Failure Troubleshooting Procedures.


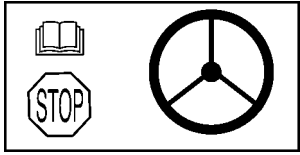
MALFUNCTION	TEST OR INSPECTION	CORRECTIVE ACTION
<p>Error Code 316 - Left-Front Wheel Sensor Circuit Failure.</p> 		<p style="text-align: center;">NOTE</p> <p>Error codes 304 or 308 may be activated with error code 316.</p> <p>Perform troubleshooting procedure for error code 312.</p>

Table 17. Error Code 339 - Grounding of Steering Wheel Sensor is Interrupted (USMC Only) Troubleshooting Procedures.

MALFUNCTION	TEST OR INSPECTION	CORRECTIVE ACTION
<p>Error Code 339 - Grounding of Steering Wheel Sensor is Interrupted (USMC Only).</p> 	<p>Perform troubleshooting procedure for error code 341 (WP 0033 00).</p>	

END OF WORK PACKAGE

HYDRAULIC SERVO SYSTEM ELECTRONIC CONTROL UNIT (ECU) (790) TROUBLESHOOTING 0036 00

THIS WORK PACKAGE COVERS

Error Code 125 - Memory Failure

Error Code 142 - Internal Communication Failure

Error Code 141 - Internal Communication Failure

INITIAL SETUP

References

TM 10-3930-675-10

Current Supply (A34738.0200) (WP 0048 00-31)

ECS Electrical Servo (A34648.0200) (WP 0048 00-5)

NOTE

- Refer to WP 0004 00 for additional troubleshooting guidance, information, and illustrations that locate critical components.
- Refer also to illustration at end of work package for component location.

Table 1. Error Code 125 - Memory Failure Troubleshooting Procedures.

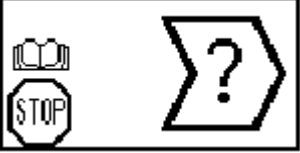

MALFUNCTION	TEST OR INSPECTION	CORRECTIVE ACTION
<p>Error Code 125 - Memory Failure.</p> 	<p>Place ignition switch in OFF position for 30 seconds and then back in ON position.</p>	<p>Replace ECU (790) if error code is still present (WP 0080 00).</p>

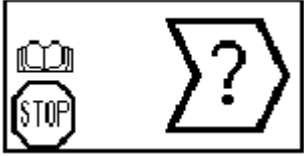
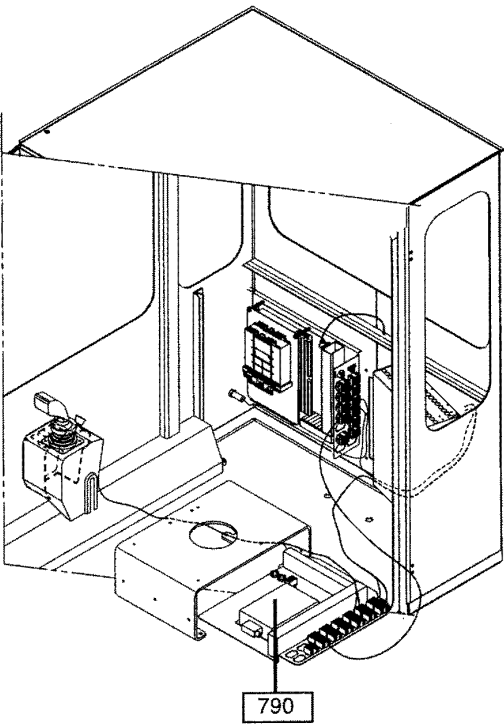
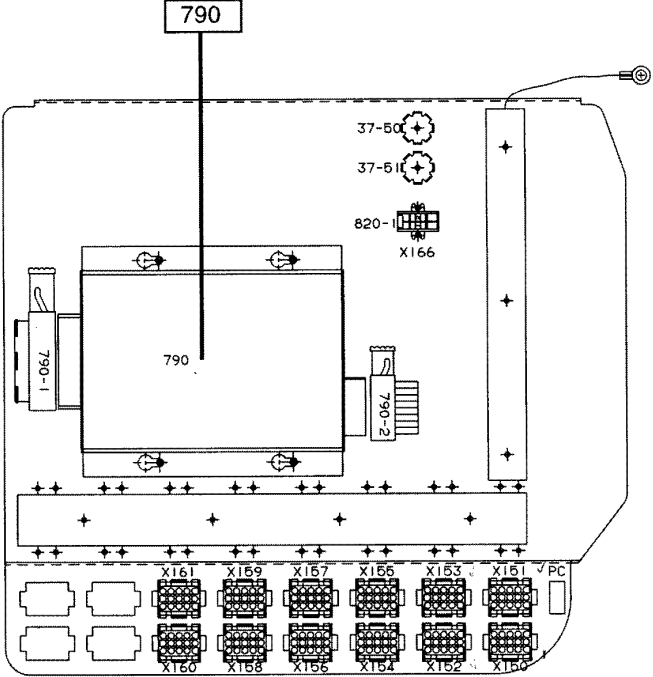
Table 2. Error Code 141 - Internal Communication Failure Troubleshooting Procedures.

MALFUNCTION	TEST OR INSPECTION	CORRECTIVE ACTION
<p>Error Code 141 - Internal Communication Failure.</p> 	<p>Place ignition switch in OFF position for 30 seconds and then back in ON position.</p>	<p>Replace ECU (790) if error code is still present (WP 0080 00).</p>

HYDRAULIC SERVO SYSTEM ELECTRONIC CONTROL UNIT (ECU) (790)
TROUBLESHOOTING - CONTINUED

0036 00

Table 3. Error Code 142 - Internal Communication Failure Troubleshooting Procedures.

MALFUNCTION	TEST OR INSPECTION	CORRECTIVE ACTION
<p data-bbox="147 443 724 506">Error Code 142 - Internal Communication Failure.</p>  	<p data-bbox="724 443 1096 541">Place ignition switch in OFF position for 30 seconds and then back in ON position.</p>	<p data-bbox="1096 443 1471 506">Replace ECU (790) if error code is still present (WP 0080 00).</p>  <p data-bbox="1370 1465 1442 1486">350-1034</p>

END OF WORK PACKAGE

AUXILIARY PUMP TROUBLESHOOTING

0037 00

THIS WORK PACKAGE COVERS

Error Code 169 - Tophandler Emergency Function Supply Valve, Open or Short Circuit Failure

Error Code 417 - Auxiliary Pump Switch, Circuit Input Error

Error Code 411 - Auxiliary Pump Control, Short Circuit Failure

INITIAL SETUP

References

TM 10-3930-675-10

Current Supply (A34738.0200) (WP 0048 00-31)

References - Continued

ECS Electrical Servo (A34648.0200) (WP 0048 00-5)

Auxiliary Pump (A34746.0200) (WP 0048 00-47)

NOTE

- Refer to WP 0004 00 for additional troubleshooting guidance, information, and illustrations that locate critical components.
- Refer also to illustration at end of work package for component location.

Table 1. Error Code 169 - Tophandler Emergency Function Supply Valve, Open or Short Circuit Failure Troubleshooting Procedures.

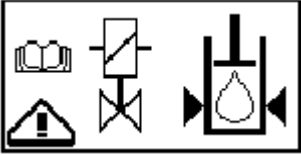
MALFUNCTION	TEST OR INSPECTION	CORRECTIVE ACTION
<p>Error Code 169 - Tophandler Emergency Function Supply Valve, Open or Short Circuit Failure.</p>  <div style="border: 1px solid black; padding: 5px; width: fit-content;"> <pre> DIAG SERVO 12(13) VALVES OUTPUT/INPUT ATTACH 0.00V 0mA PUMP OFF 0.00V 0mA </pre> </div>	<ol style="list-style-type: none"> Place ignition switch to ON but don't start engine. Access the diagnostic menu "SERVO" 12(13). Turn on auxiliary Pump and operate one of the tophandler functions. Check voltage at X158 between pin 11 and pin 12 with the ignition and the auxiliary pump on (WP 0048 00-8). Should have (21 to 24V) while operating one of the tophandler functions. 	<p>The ATTACH "OUTPUT" value should have voltage (24V) and the "INPUT" value (mA) should rise while operating a tophandler function.</p> <ol style="list-style-type: none"> If voltage (21 to 24V) found continuously, disconnect X158 and check the resistance on the loose part of X158 between pin 11 and pin 12. Resistance should be 40 to 43 Ohms. Check resistance to ground at either pin.

Table 1. Error Code 169 - Tophandler Emergency Function Supply Valve, Open or Short Circuit Failure Troubleshooting Procedures - Continued.

MALFUNCTION	TEST OR INSPECTION	CORRECTIVE ACTION
<p>Error Code 169 - Tophandler Emergency Function Supply Valve, Open or Short Circuit Failure - Continued.</p>	<p>3. Remove the engine hood (TM 10-3930-675-10). Locate the tophandler supply valve solenoid 6041, located on frame rail above engine starter. Check resistance of 6041 solenoid. Should be 40 to 43 Ohms. Check resistance of each pin to ground.</p>	<p>b. If no voltage (21 to 24V) is found, disconnect ECU (790) connector 2 and check pin 14 for damage and check continuity of wire A15812 (WP 0048 00-8).</p> <p>c. Repair or replace damaged wires or connectors (WP 0113 00).</p> <p>d. Replace damaged ECU (790) (WP 0080 00).</p> <p>a. If resistance (40 to 43 Ohms) is not as specified or solenoid is shorted to ground, replace tophandler supply valve (6041) (WP 0263 00).</p> <p>b. If specified resistance is found, check continuity of wires 15811 and 15812 (WP 0048 00-8).</p> <p>c. Notify Sustainment Maintenance to replace damaged or open harness.</p> <p>d. Replace ECU (790) (WP 0080 00).</p>

Table 2. Error Code 411 - Auxiliary Pump Control, Short Circuit Failure Troubleshooting Procedures.

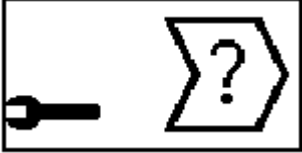
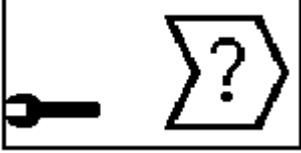
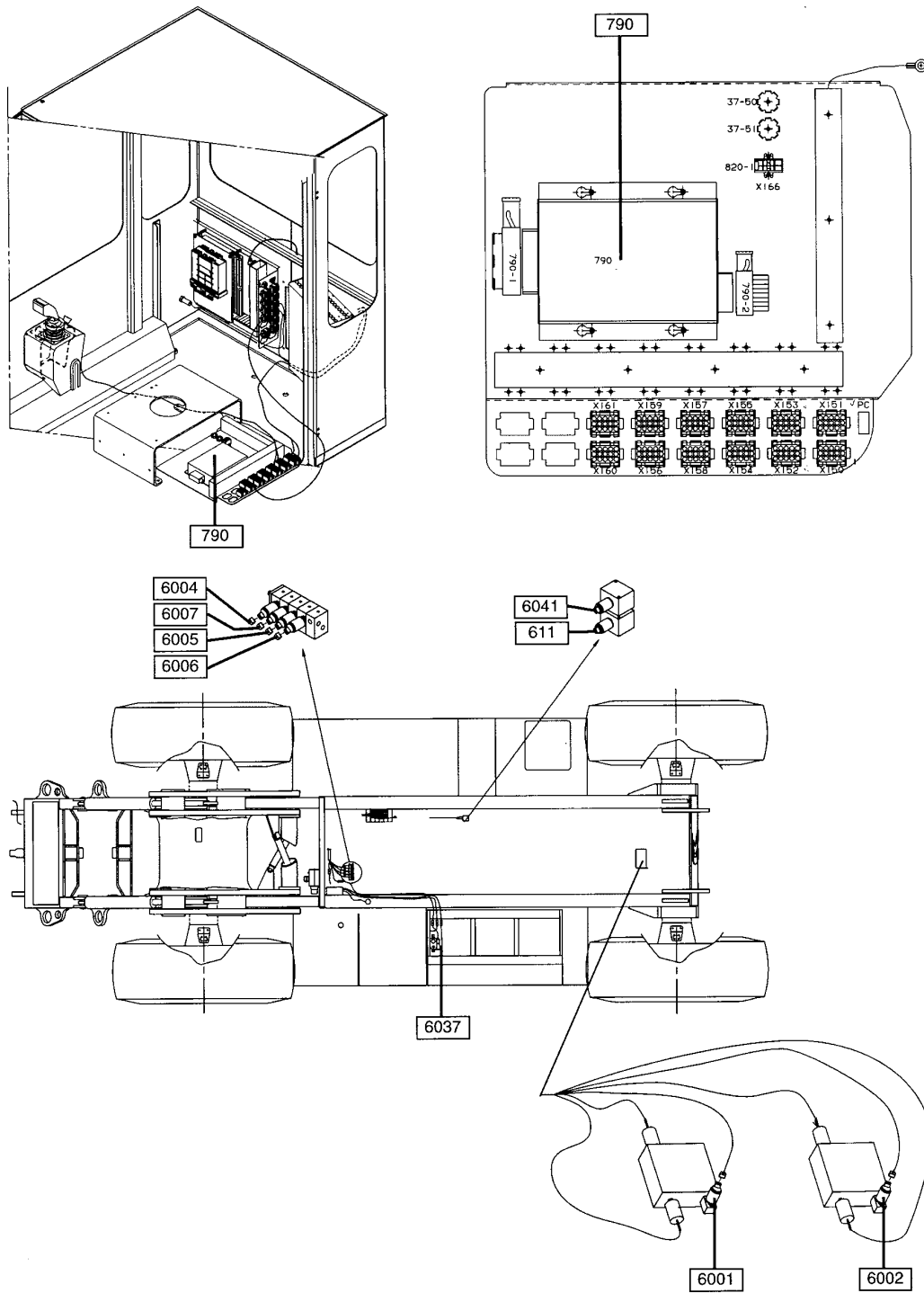
MALFUNCTION	TEST OR INSPECTION	CORRECTIVE ACTION
<p data-bbox="159 407 717 468">Error Code 411 - Auxiliary Pump Control, Short Circuit Failure.</p> 	<p data-bbox="1047 407 1144 441" style="text-align: center;">NOTE</p> <p data-bbox="781 457 1414 642">Error code 411 is an information type error code. It may not activate for the operator. The operator may report the auxiliary pump is not working. Enter DIAG STEERING 2(16) in the Diagnostic menu to verify the code or enable the information type codes in the Initialization menu.</p> <ol style="list-style-type: none"> <li data-bbox="735 663 1089 911">1. Test relay. Remove the plastic cover from the right rear of the cab to access the cab distribution box (WP 0074 00). Open the cab distribution box to access the relay boards. Remove relay 350 and test (WP 0113 00). <li data-bbox="735 932 1089 1180">2. Check for continuity. Disconnect connector X174 located in the middle panel. Check for continuity to ground on the loose part of X174 at pin 5 (WP 0048 00-19). There should not be continuity to ground. <li data-bbox="735 1234 1089 1482">3. Check for continuity. Disconnect connector X46 and connector XK3 located on one of the relay boards. Check for continuity to ground on the loose part of XK3 at pin 8 (WP 0048 00-47). There should not be continuity to ground. <li data-bbox="735 1503 1089 1596">4. Check ECU (792) pin 61 for connection or damage (WP 0048 00-16). 	<p data-bbox="1105 663 1450 785">Replace relay if resistance between terminals 85 and 86 is not 290 to 350 Ohms (WP 0074 00).</p> <ol style="list-style-type: none"> <li data-bbox="1105 932 1463 1024">a. If continuity to ground is found, disconnect X46 and recheck. <li data-bbox="1105 1031 1463 1152">b. If continuity to ground is still found, check wire 469 for continuity to ground (WP 0048 00-16). <li data-bbox="1105 1159 1463 1213">c. Replace grounded X174 to X46 cable (WP 0113 00). <li data-bbox="1105 1234 1463 1289">a. If continuity to ground is found, replace wire A469. <li data-bbox="1105 1295 1463 1417">b. If continuity to ground is not found, check wire A1745 for continuity to ground (WP 0048 00-16). <li data-bbox="1105 1423 1463 1478">c. Replace grounded wire A1745. <li data-bbox="1105 1503 1463 1558">a. Replace damaged ECU (792) terminal board (WP 0080 00). <li data-bbox="1105 1564 1463 1619">b. Replace ECU (792) (WP 0080 00).

Table 3. Error Code 417 - Auxiliary Pump Switch, Circuit Input Error Troubleshooting Procedures.

MALFUNCTION	TEST OR INSPECTION	CORRECTIVE ACTION
<p>Error Code 417 - Auxiliary Pump Switch, Circuit Input Error.</p> 	<p style="text-align: center;">NOTE</p> <p>Error code 417 is an information type error code. It may not activate for the operator. Enter DIAG STEERING 2(16) in the Diagnostic menu to verify the code or enable the information type codes in the Initialization menu. Input error type codes can be activated if the voltage input is not stable due to a bad connection.</p> <ol style="list-style-type: none"> 1. Inspect the auxiliary pump switch for damage and connection. 2. Inspect connectors X67, X47, and X174 for connection or damage. 3. Check ECU (792) pin 48 for connection or damage (WP 0048 00-18). 4. Check wire connection. Disconnect wire A1744 from ECU (792) and recheck for active 417 error code. 	<p>Replace damaged auxiliary pump switch (WP 0073 00).</p> <ol style="list-style-type: none"> a. Repair or replace damaged connector (WP 0113 00). b. If connectors are found to be in good condition, check wires A678 (WP 0048 00-32), A671 (WP 0048 00-46), 671 and 672 (WP 0048 00-47), and A474 and 474 (WP 0048 00-18) for continuity. c. Replace or repair open or damaged wire. a. Check wire A1744 for continuity (WP 0048 00-18). b. Replace damaged ECU (792) terminal board (WP 0113 00). <p>Replace ECU (792) (WP 0113 00) if error code 417 is still active.</p>



350-1035

END OF WORK PACKAGE

THIS WORK PACKAGE COVERS

Error Code 172 - Hydraulic Piston Pump Cut-Off, Open or Short Circuit Failure

INITIAL SETUP

References

- TM 10-3930-675-10
- Current Supply (A34738.0200) (WP 0048 00-31)
- ECS Electrical Servo (A34648.0200) (WP 0048 00-5)

NOTE

- Refer to WP 0004 00 for additional troubleshooting guidance, information, and illustrations that locate critical components.
- Refer also to illustration at end of work package for component location.

Table 1. Error Code 172 - Hydraulic Piston Pump Cut-Off, Open or Short Circuit Failure Troubleshooting Procedures.

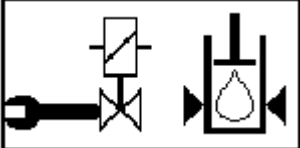
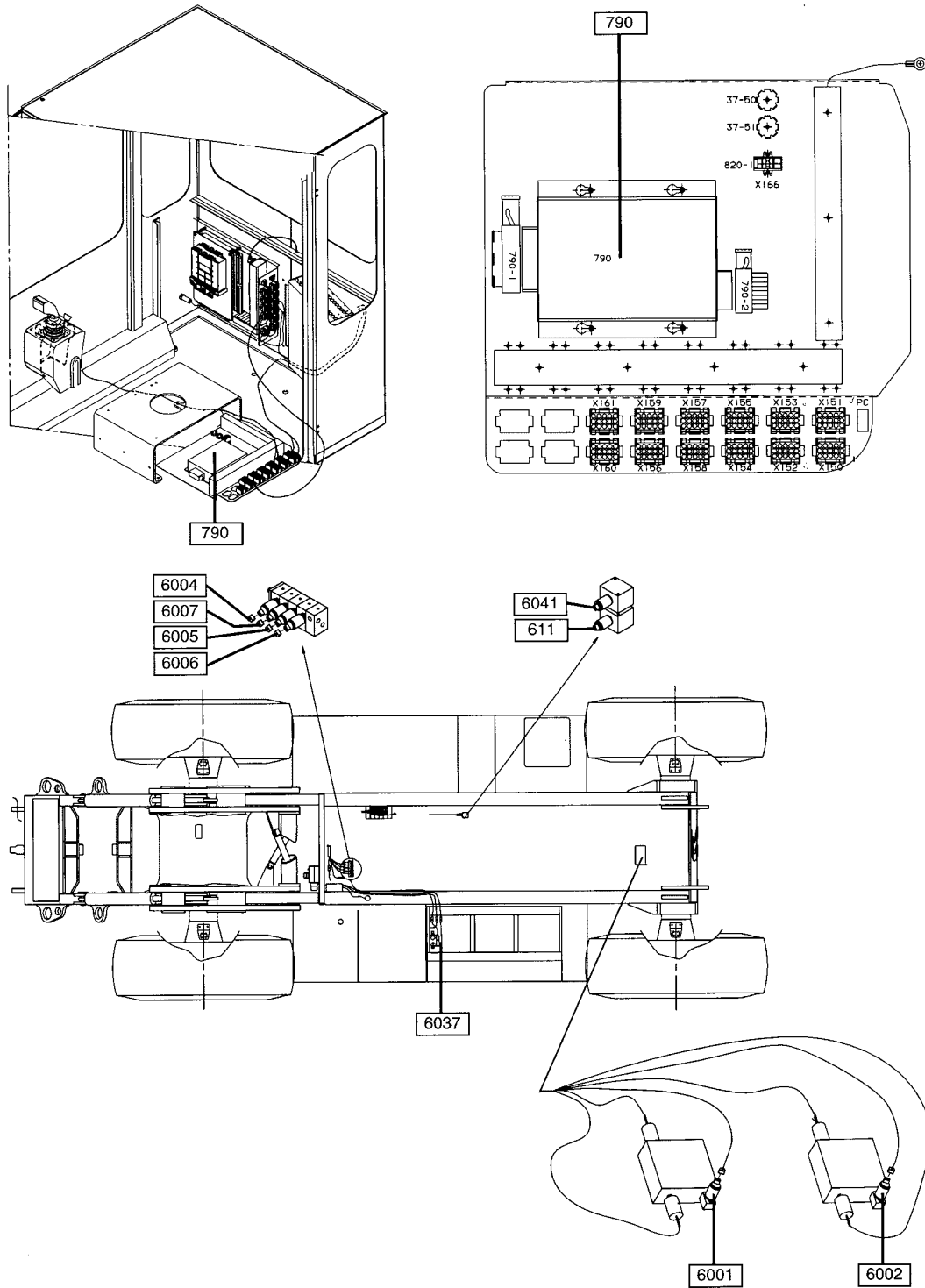
MALFUNCTION	TEST OR INSPECTION	CORRECTIVE ACTION
<p>Error Code 172 - Hydraulic Piston Pump Cut-Off, Open or Short Circuit Failure.</p>  <div style="border: 1px solid black; padding: 5px; width: fit-content;"> <p>TEST OR INSPECTION- EXTRA FUNCT. 2(13)</p> <p>CUT-OFF THE 0 HYDRAULIC PUMP</p> </div>	<p>1. Place ignition switch to ON but don't start engine. Access the diagnostic menu "SERVO" 12(13). The PUMP OFF "OUTPUT" value should have voltage (24V) and the "INPUT" value should have (mA). (Slow cranking of the engine is a sign the pumps are engaged during engine start).</p>	<p>a. Start engine. The voltage (24V) and (mA) values should go away when the pumps engage.</p> <p>b. If values do not go away, ensure the engine cold start function is not activated (TM 10-3930-675-10).</p> <p>c. If values still do not go away, Replace ECU (790) (WP 0080 00).</p>

Table 1. Error Code 172 - Hydraulic Piston Pump Cut-Off, Open or Short Circuit Failure Troubleshooting Procedures - Continued.

MALFUNCTION	TEST OR INSPECTION	CORRECTIVE ACTION
<p>Error Code 172 - Hydraulic Piston Pump Cut-Off, Open or Short Circuit Failure - Continued.</p>	<p>2. Check voltage at X158 between pin 13 and pin 14 with the ignition ON (WP 0048 00-8). Should have voltage (21 to 24V).</p> <p>3. Remove the engine hood (TM 10-3930-675-10). Locate the hydraulic pump cut-off valve solenoid 611, located on frame rail above engine starter. Check resistances of 611 solenoid. Should be 40 to 43 Ohms. Check resistance of each pin to ground.</p>	<p>a. If voltage (21 to 24V) is found continuously, disconnect X158 and check the resistance on the loose part of X158 between pin 13 and pin 14. Resistance should be 40 to 43 Ohms. Check resistance to ground at either pin.</p> <p>b. If no voltage (21 to 24V) is found, disconnect ECU (790) connector 2 and check pin 6 for damage and check continuity of wire A15814 (WP 0048 00-8).</p> <p>c. Repair or replace damaged wires or connectors (WP 0113 00).</p> <p>d. Replace damaged ECU (790) (WP 0080 00).</p> <p>a. If resistance (40 to 43 Ohms) is not as specified or solenoid is shorted to ground, replace hydraulic pump cut-off valve (611) (WP 0263 00).</p> <p>b. If specified resistance is found, check continuity of wires 15813 and 15814 (WP 0048 00-8).</p> <p>c. Notify Sustainment Maintenance to replace damaged or open harness.</p> <p>d. Replace ECU (790) (WP 0080 00).</p>



350-1035

END OF WORK PACKAGE

HYDRAULIC FILTER INDICATORS TROUBLESHOOTING

0039 00

THIS WORK PACKAGE COVERS

- Error Code 1 - Boom Hydraulic System Sensor Indicating Clogged Filter
- Error Code 2 - Steering Hydraulic System Sensor Indicating Clogged Filter
- Error Code 3 - Tophandler Hydraulic System Sensor Indicating Clogged Filter
- Error Code 4 - Hydraulic Reservoir Return Sensor Indicating Clogged Filter
- Error Code 432 - Boom Hydraulic Filter Sensor, Circuit Input Error

- Error Code 433 - Steering Hydraulic Filter Sensor, Circuit Input Error
- Error Code 434 - Tophandler Hydraulic Filter Sensor, Circuit Input Error
- Error Code 435 - Hydraulic Reservoir Return System Filter Sensor, Circuit Input Error
- Error Code 786 - Transmission Hydraulic System Filter Sensor Indicating Clogged Filter

INITIAL SETUP

References

- TM 10-3930-675-10
- ECS Hydraulics (A34654.0200) (WP 0048 00-29)


Equipment Condition

- Cab moved to transport position (TM 10-3930-675-10)

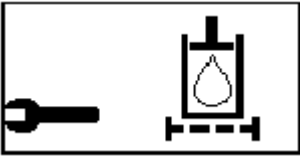
NOTE

- Refer to WP 0004 00 for additional troubleshooting guidance, information, and illustrations that locate critical components.
- Refer also to illustrations at end of work package for component location.

Table 1. Error Code 1 - Boom Hydraulic System Sensor Indicating Clogged Filter Troubleshooting Procedures.

MALFUNCTION	TEST OR INSPECTION	CORRECTIVE ACTION										
<p>Error Code 1 - Boom Hydraulic System Sensor Indicating Clogged Filter.</p> <div style="text-align: center;">  </div> <table border="1" style="width: 100%; border-collapse: collapse;"> <tr> <td>EXTRA FUNCT.</td> <td style="text-align: right;">6(13)</td> </tr> <tr> <td>HYD.FILTER BOOM</td> <td style="text-align: right;">0</td> </tr> <tr> <td>HYD.FILTER STEERING</td> <td style="text-align: right;">0</td> </tr> <tr> <td>HYD.FILTER ATTACH</td> <td style="text-align: right;">0</td> </tr> <tr> <td>HYD.FILTER RET.OIL</td> <td style="text-align: right;">0</td> </tr> </table>	EXTRA FUNCT.	6(13)	HYD.FILTER BOOM	0	HYD.FILTER STEERING	0	HYD.FILTER ATTACH	0	HYD.FILTER RET.OIL	0		<p>Replace filters (WP 0185 00).</p>
EXTRA FUNCT.	6(13)											
HYD.FILTER BOOM	0											
HYD.FILTER STEERING	0											
HYD.FILTER ATTACH	0											
HYD.FILTER RET.OIL	0											

**Table 2. Error Code 2 - Steering Hydraulic System
Sensor Indicating Clogged Filter Troubleshooting Procedures.**

MALFUNCTION	TEST OR INSPECTION	CORRECTIVE ACTION										
<p>Error Code 2 - Steering Hydraulic System Sensor Indicating Clogged Filter.</p>  <table border="1" data-bbox="289 688 586 825"> <tr> <td>EXTRA FUNCT.</td> <td>6(13)</td> </tr> <tr> <td>HYD.FILTER BOOM</td> <td>0</td> </tr> <tr> <td>HYD.FILTER STEERING</td> <td>0</td> </tr> <tr> <td>HYD.FILTER ATTACH</td> <td>0</td> </tr> <tr> <td>HYD.FILTER RET.OIL</td> <td>0</td> </tr> </table>	EXTRA FUNCT.	6(13)	HYD.FILTER BOOM	0	HYD.FILTER STEERING	0	HYD.FILTER ATTACH	0	HYD.FILTER RET.OIL	0		<p>Replace filters (WP 0185 00).</p>
EXTRA FUNCT.	6(13)											
HYD.FILTER BOOM	0											
HYD.FILTER STEERING	0											
HYD.FILTER ATTACH	0											
HYD.FILTER RET.OIL	0											

**Table 3. Error Code 3 - Tophandler Hydraulic System
Sensor Indicating Clogged Filter Troubleshooting Procedures.**

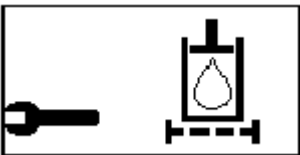
MALFUNCTION	TEST OR INSPECTION	CORRECTIVE ACTION										
<p>Error Code 3 - Tophandler Hydraulic System Sensor Indicating Clogged Filter.</p>  <table border="1" data-bbox="289 1289 586 1425"> <tr> <td>EXTRA FUNCT.</td> <td>6(13)</td> </tr> <tr> <td>HYD.FILTER BOOM</td> <td>0</td> </tr> <tr> <td>HYD.FILTER STEERING</td> <td>0</td> </tr> <tr> <td>HYD.FILTER ATTACH</td> <td>0</td> </tr> <tr> <td>HYD.FILTER RET.OIL</td> <td>0</td> </tr> </table>	EXTRA FUNCT.	6(13)	HYD.FILTER BOOM	0	HYD.FILTER STEERING	0	HYD.FILTER ATTACH	0	HYD.FILTER RET.OIL	0		<p>Replace filters (WP 0185 00).</p>
EXTRA FUNCT.	6(13)											
HYD.FILTER BOOM	0											
HYD.FILTER STEERING	0											
HYD.FILTER ATTACH	0											
HYD.FILTER RET.OIL	0											

Table 4. Error Code 4 - Hydraulic Reservoir Return Sensor Indicating Clogged Filter Troubleshooting Procedures.

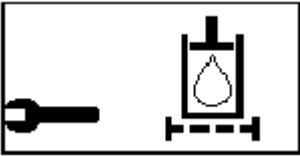
MALFUNCTION	TEST OR INSPECTION	CORRECTIVE ACTION										
<p>Error Code 4 - Hydraulic Reservoir Return Sensor Indicating Clogged Filter.</p>  <table border="1" data-bbox="289 688 586 825"> <tr> <td>EXTRA FUNCT.</td> <td>6(13)</td> </tr> <tr> <td>HYD.FILTER BOOM</td> <td>0</td> </tr> <tr> <td>HYD.FILTER STEERING</td> <td>0</td> </tr> <tr> <td>HYD.FILTER ATTACH</td> <td>0</td> </tr> <tr> <td>HYD.FILTER RET.OIL</td> <td>0</td> </tr> </table>	EXTRA FUNCT.	6(13)	HYD.FILTER BOOM	0	HYD.FILTER STEERING	0	HYD.FILTER ATTACH	0	HYD.FILTER RET.OIL	0		<p>Replace filters (WP 0185 00).</p>
EXTRA FUNCT.	6(13)											
HYD.FILTER BOOM	0											
HYD.FILTER STEERING	0											
HYD.FILTER ATTACH	0											
HYD.FILTER RET.OIL	0											

Table 5. Error Code 432 - Boom Hydraulic Filter Sensor, Circuit Error Input Troubleshooting Procedures.

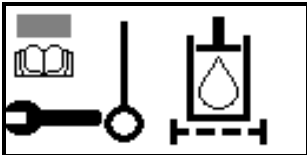
MALFUNCTION	TEST OR INSPECTION	CORRECTIVE ACTION
<p>Error Code 432 - Boom Hydraulic Filter Sensor, Circuit Error Input.</p> 	<p style="text-align: center;">NOTE</p> <p>Error code 432 is an information type error code. It may not activate for the operator. Enter DIAG STEERING 2(16) in the Diagnostic menu to verify the code or enable the information type codes in the Initialization menu. Input error type codes can be activated if the voltage input is not stable due to a bad connection.</p> <ol style="list-style-type: none"> 1. Inspect the boom hydraulic filter sensor (755-1) for damage and connection. 2. Inspect connectors X198 (located under the cab and rear cover plate), X195, X197, X174 (X174B RESET only), and X47 for connection or damage. 	<p>Replace damaged boom hydraulic sensor (755-1) (WP 0103 00).</p> <ol style="list-style-type: none"> a. Repair or replace damaged connector (WP 0113 00). b. If connectors are found to be in good condition, check wires BK, BU, GY, A1743C (WP 0048 00-29), A1743B, 473 (WP 0048 00-16), A473 (WP 0048 00-38), A174B1B, A174B1A, 475, and A475 RESET only (WP 0048 00-18) for continuity. c. Replace or repair open or damaged wire.

Table 5. Error Code 432 - Boom Hydraulic Filter Sensor, Circuit Error Input Troubleshooting Procedures - Continued.

MALFUNCTION	TEST OR INSPECTION	CORRECTIVE ACTION
Error Code 432 - Boom Hydraulic Filter Sensor, Circuit Error Input - Continued.	3. Check ECU (792) pin 154 for connection or damage (WP 0048 00-29). 4. Check for wire connection. Disconnect wire A1951 from ECU (792) and recheck for active 432 error code.	a. Check wire A1951 for continuity (WP 0048 00-29). b. Replace damaged ECU (792) terminal board (WP 0080 00). Replace ECU (792) (WP 0080 00) if error code 432 is still active.

Table 6. Error Code 433 - Steering Hydraulic Filter Sensor, Circuit Input Error Troubleshooting Procedures.

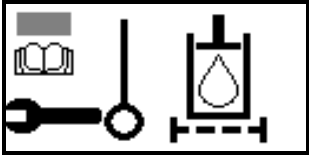
MALFUNCTION	TEST OR INSPECTION	CORRECTIVE ACTION
Error Code 433 - Steering Hydraulic Filter Sensor, Circuit Input Error. 	<p style="text-align: center;">NOTE</p> <p>Error code 433 is an information type error code. It may not activate for the operator. Enter DIAG STEERING 2(16) in the Diagnostic menu to verify the code or enable the information type codes in the Initialization menu. Input error type codes can be activated if the voltage input is not stable due to a bad connection.</p>	<p style="text-align: center;">NOTE</p>
	1. Inspect the steering hydraulic filter sensor (755-2) for damage and connection. 2. Inspect connectors X198 (located under the cab and rear cover plate), X195, X197, X174 (X174B RESET only), and X47 for connection or damage. 3. Check ECU (792) pin 153 for connection or damage (WP 0048 00-29). 4. Check for wire connection. Disconnect wire A1952 from ECU (792) and recheck for active 433 error code.	Replace damaged steering hydraulic sensor (755-2) (WP 0103 00). a. Repair or replace damaged connector (WP 0113 00). b. If connectors are found to be in good condition, check wires BK, YE, GY, A1743C (WP 0048 00-29), A1743B, 473 (WP 0048 00-16), A473 (WP 0048 00-38), A174B1B, A174B1A, 475, and A475 RESET only (WP 0048 00-18) for continuity. c. Check wire A1952 for continuity (WP 0048 00-29). a. Check wire A1952 for continuity (WP 0048 00-29). b. Replace damaged ECU (792) terminal board (WP 0080 00). Replace ECU (792) (WP 0080 00) if error code 433 is still active.

Table 7. Error Code 434 - Tophandler Hydraulic Filter Sensor, Circuit Input Error Troubleshooting Procedures.

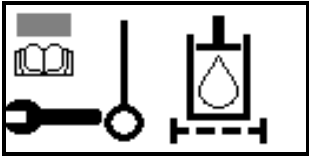
MALFUNCTION	TEST OR INSPECTION	CORRECTIVE ACTION
<p data-bbox="159 441 722 504">Error Code 434 - Tophandler Hydraulic Filter Sensor, Circuit Input Error.</p> 	<p data-bbox="1047 441 1144 472" style="text-align: center;">NOTE</p> <p data-bbox="779 489 1412 678">Error code 434 is an information type error code. It may not activate for the operator. Enter DIAG STEERING 2(16) in the Diagnostic menu to verify the code or enable the information type codes in the Initialization menu. Input error type codes can be activated if the voltage input is not stable due to a bad connection.</p> <ol style="list-style-type: none"> <li data-bbox="735 720 1089 810">1. Inspect the tophandler hydraulic filter sensor (755-3) for damage and connection. <li data-bbox="735 831 1089 1020">2. Inspect connectors X198 (located under the cab and rear cover plate), X195, X197, X174 (X174B RESET only), and X47 for connection or damage. <li data-bbox="735 1266 1089 1356">3. Check ECU (792) pin 152 for connection or damage (WP 0048 00-29). <li data-bbox="735 1409 1089 1535">4. Check for wire connection. Disconnect wire A1953 from ECU (792) and recheck for active 434 error code. 	<p data-bbox="1105 720 1425 810">Replace damaged tophandler hydraulic sensor (755-3) (WP 0103 00).</p> <ol style="list-style-type: none"> <li data-bbox="1105 831 1458 888">a. Repair or replace damaged connector (WP 0113 00). <li data-bbox="1105 894 1458 1178">b. If connectors are found to be in good condition, check wires BK, GN, GY, A1743C (WP 0048 00-29), A1743B, 473 (WP 0048 00-16), A473 (WP 0048 00-38), A174B1B, A174B1A, 475, and A475 RESET only (WP 0048 00-18) for continuity. <li data-bbox="1105 1188 1409 1245">c. Replace or repair open or damaged wire. <ol style="list-style-type: none"> <li data-bbox="1105 1266 1458 1323">a. Check wire A1953 for continuity (WP 0048 00-29). <li data-bbox="1105 1329 1458 1386">b. Replace damaged ECU (792) terminal board (WP 0080 00). <p data-bbox="1105 1409 1458 1472">Replace ECU (792) (WP 0080 00) if error code 434 is still active.</p>

Table 8. Error Code 435 - Hydraulic Reservoir Return System Filter Sensor, Circuit Input Error Troubleshooting Procedures.



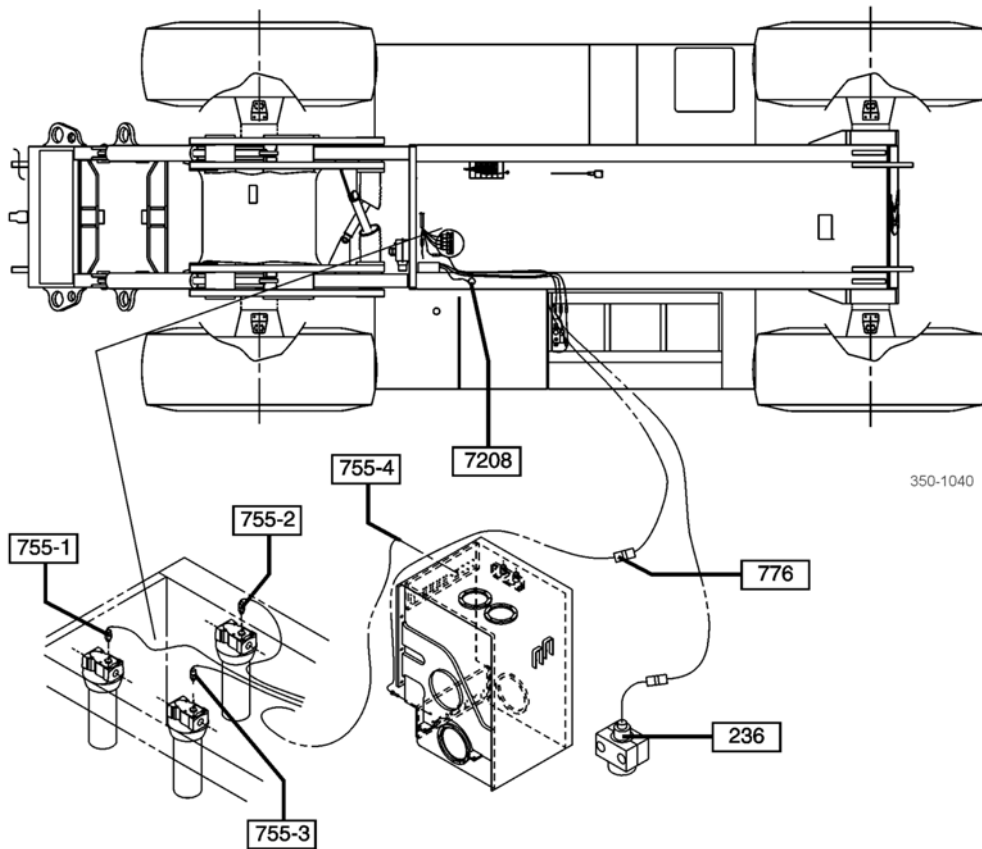
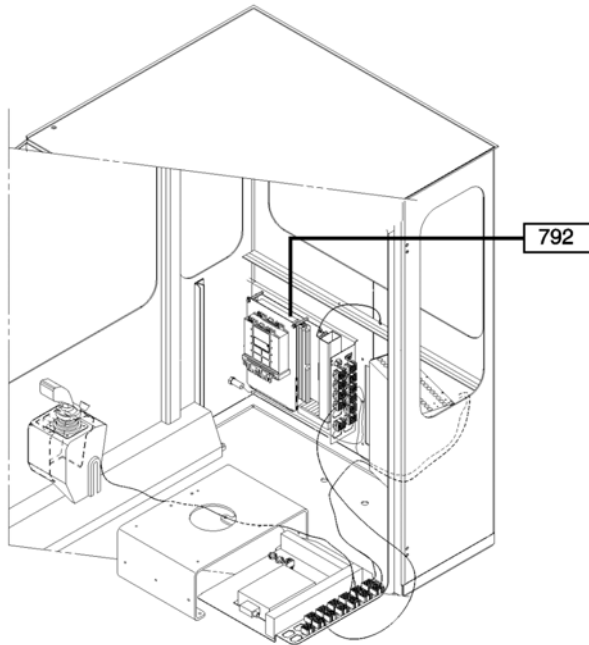
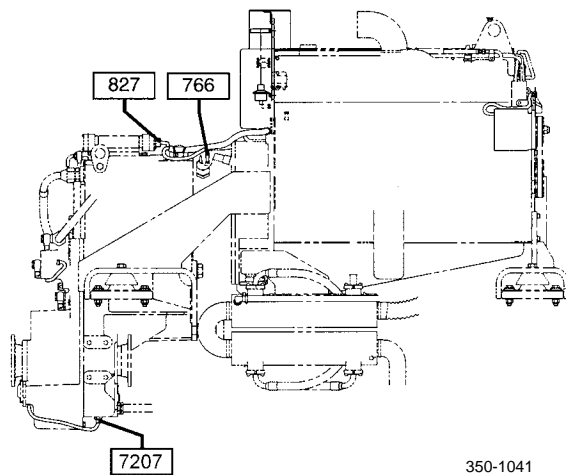
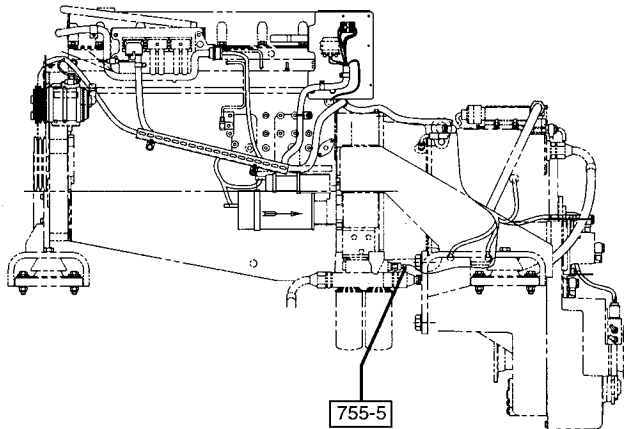
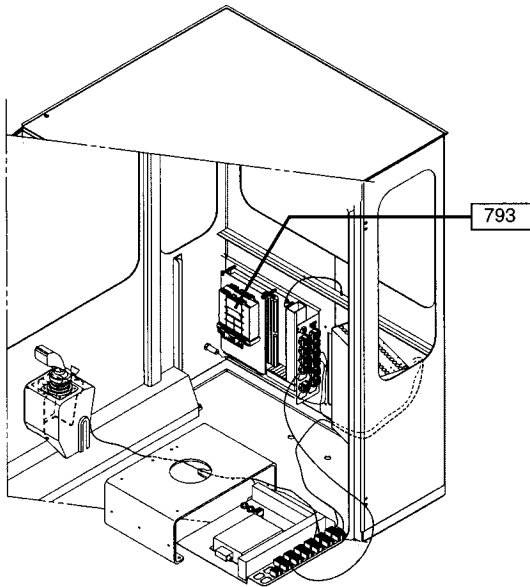
MALFUNCTION	TEST OR INSPECTION	CORRECTIVE ACTION
<p data-bbox="147 432 724 499">Error Code 435 - Hydraulic Reservoir Return System Filter Sensor, Circuit Input Error.</p> 	<p data-bbox="1045 432 1146 468" style="text-align: center;">NOTE</p> <p data-bbox="781 485 1414 674">Error code 435 is an information type error code. It may not activate for the operator. Enter DIAG STEERING 2(16) in the Diagnostic menu to verify the code or enable the information type codes in the Initialization menu. Input error type codes can be activated if the voltage input is not stable due to a bad connection.</p> <ol style="list-style-type: none"> <li data-bbox="735 726 1089 821">1. Inspect the return hydraulic filter sensor (755-4) for damage and connection. <li data-bbox="735 842 1089 1024">2. Inspect connectors X198 (located under the cab and rear cover plate), X195, X197, X174 (X174B RESET only), and X47 for connection or damage. <li data-bbox="735 1276 1089 1371">3. Check ECU (792) pin 151 for connection or damage (WP 0048 00-29). <li data-bbox="735 1423 1089 1539">4. Check for wire connection. Disconnect wire A1954 from ECU (792) and recheck for active 435 error code. 	<p data-bbox="1096 726 1425 821">Replace damaged return hydraulic sensor (755-4) (WP 0103 00).</p> <ol style="list-style-type: none"> <li data-bbox="1096 842 1463 898">a. Repair or replace damaged connector (WP 0113 00). <li data-bbox="1096 905 1463 1188">b. If connectors are found to be in good condition; check wires BK, BN, GY, A1743C (WP 0048 00-29), A1743B, 473 (WP 0048 00-16), A473 (WP 0048 00-38), A174B1B, A174B1A, 475, and A475 RESET only (WP 0048 00-18) for continuity. <li data-bbox="1096 1199 1414 1255">c. Replace or repair open or damaged wire. <li data-bbox="1096 1276 1463 1333">a. Check wire A1954 for continuity (WP 0048 00-29). <li data-bbox="1096 1339 1463 1396">b. Replace damaged ECU (792) terminal board (WP 0080 00). <p data-bbox="1096 1423 1463 1480">Replace ECU (792) (WP 0080 00) if error code 435 is still active.</p>

Table 9. Error Code 786 - Transmission Hydraulic System
Sensor Indicating Clogged Filter Troubleshooting Procedures.

MALFUNCTION	TEST OR INSPECTION	CORRECTIVE ACTION
<p data-bbox="159 443 719 506">Error Code 786 - Transmission Hydraulic System Sensor Indicating Clogged Filter.</p> 		<p data-bbox="1105 443 1422 474">Replace filters (WP 0117 00).</p>



350-1040



350-1041

END OF WORK PACKAGE

BOOM LIFTING/LOWERING TROUBLESHOOTING

0040 00

THIS WORK PACKAGE COVERS

Error Code 126 - Joystick-to-ECU (790) Failure

Error Code 130 - Overload Protection System Failure

Error Code 151 - Lift Cylinder Locking Valve, Wiring Circuit Failure

Error Code 152 - Lift Cylinder Locking Valve, Component Failure

Error Code 154 - Lift Cylinder Boom Up Valve, Wiring Circuit Failure

Error Code 155 - Lift Cylinder Boom Up Valve, Component Failure

Error Code 157 - Lift Cylinder Boom Down Valve, Wiring Circuit Failure

Error Code 158 - Lift Cylinder Boom Down Valve, Component Failure

INITIAL SETUP

References

TM 10-3930-675-10

Current Supply (A34738.0200) (WP 0048 00-31)

ECS Electrical Servo (A34648.0200) (WP 0048 00-5)

NOTE

- Refer to WP 0004 00 for additional troubleshooting guidance, information, and illustrations that locate critical components.
- Refer also to illustrations at end of work package for component location.

Table 1. Error Code 126 - Joystick-to-ECU (790) Failure Troubleshooting Procedures.

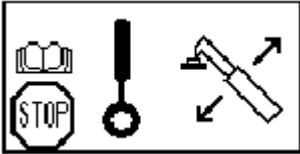
MALFUNCTION	TEST OR INSPECTION	CORRECTIVE ACTION						
<p>Error Code 126 - Joystick-to-ECU (790) Failure.</p>  <table border="1" data-bbox="300 1759 597 1885"> <tr> <td>DIAG SERVO</td> <td>5 (13)</td> </tr> <tr> <td>LIFT/LOWER</td> <td>5.00V</td> </tr> <tr> <td>BOOM IN/OUT</td> <td>5.00V</td> </tr> </table>	DIAG SERVO	5 (13)	LIFT/LOWER	5.00V	BOOM IN/OUT	5.00V	<p>1. Enter diagnostic menu “DIAG SERVO” 5(13) and check LIFT/LOWER voltage. Voltage should be around 5V with no movement of the joystick.</p>	<p>a. Operate the joystick lift and lower function slowly. Should have 1 to 9V over the full range of function. If the voltage suddenly goes out of range, replace joystick (WP 0082 00).</p> <p>b. If no voltage (5V) is found, continue with step 2.</p>
DIAG SERVO	5 (13)							
LIFT/LOWER	5.00V							
BOOM IN/OUT	5.00V							

Table 1. Error Code 126 - Joystick-to-ECU (790) Failure Troubleshooting Procedures - Continued.

MALFUNCTION	TEST OR INSPECTION	CORRECTIVE ACTION
<p>Error Code 126 - Joystick-to-ECU (790) Failure - Continued.</p>	<p>2. Inspect ECU (790) connector</p> <p>1. Check connector, harness and ECU (790) for damage. Check ECU tray ground wires</p> <p>3. Check voltage (10V) at X155 between pins 12 and 13 with the ignition ON (WP 0048 00-6).</p> <p>4. Check voltage (10V) at X155 between pins 1 and 13 with the ignition ON (WP 0048 00-6). Should be around 5V.</p>	<p>a. Repair or replace damaged wires or connectors (WP 0113 00).</p> <p>b. Replace damaged ECU (790) (WP 0080 00).</p> <p>a. If no voltage (10V) is found, check continuity of wires A15514A, A15514B, and A15513A (WP 0048 00-6).</p> <p>b. Repair or replace damaged wires or connectors (WP 0113 00).</p> <p>a. If no voltage (5V) is found, check continuity of wires 15512, 1551, A1551, and 15513 (WP 0048 00-6).</p> <p>b. Replace damaged or open joystick harness (WP 0083 00).</p> <p>c. Replace joystick (WP 0082 00).</p>

Table 2. Error Code 130 - Overload Protection System Failure Troubleshooting Procedures.


MALFUNCTION	TEST OR INSPECTION	CORRECTIVE ACTION
<p>Error Code 130 - Overload Protection System Failure.</p> 	<p>Overload protection system failure occurs due to an earlier failure (error codes 131 to 136) on any component related to the overload protection system. Hydraulic speeds are limited and the error code will flash on the display every 5 seconds.</p>	<p>Perform troubleshooting procedures for the original error code (error codes 131 to 136).</p>

Table 3. Error Code 151 - Lift Cylinder Locking Valve, Wiring Circuit Failure Troubleshooting Procedures.

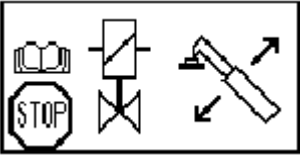
MALFUNCTION	TEST OR INSPECTION	CORRECTIVE ACTION												
<p>Error Code 151 - Lift Cylinder Locking Valve, Wiring Circuit Failure.</p>  <table border="1" data-bbox="297 684 599 821"> <tr> <td>DIAG SERVO</td> <td>11(13)</td> <td></td> </tr> <tr> <td></td> <td>OUTPUT/INPUT</td> <td></td> </tr> <tr> <td>FAN</td> <td>0mA</td> <td>0mA</td> </tr> <tr> <td>BL. VALVE</td> <td>0.00V</td> <td>0mA</td> </tr> </table>	DIAG SERVO	11(13)			OUTPUT/INPUT		FAN	0mA	0mA	BL. VALVE	0.00V	0mA	<ol style="list-style-type: none"> 1. Enter "DIAG SERVO" 11(13) in the diagnostic menu. Should have 24V when activating boom lowering function. 2. Disconnect the connectors from 6001 and 6002 from the lift cylinder locking valves. Check voltage between the two pins of each connector with the ignition ON. Should have voltage 24V during the lowering function. 3. Check voltage 24V at X159 pin 2 with the ignition ON. Should have 24V (WP 0048 00-8). 4. Remove the engine cover to access X167 and check voltage (24V) at X167 pin 14 and 15 with the ignition ON (WP 0048 00-8). 	<p>Inspect locking valve solenoids for damage and proper connector.</p> <ol style="list-style-type: none"> a. If no voltage (24V) is found, check continuity of locking valve harness. b. If voltage (24V) is found, check resistance of locking valve solenoids (6001 and 6002). The resistance should be 18 to 20 Ohms. c. Replace damaged or open locking valve harness. d. Replace locking valve (WP 0252 00). <ol style="list-style-type: none"> a. If no voltage (24V) is found, disconnect ECU (790) connector 2 and check pin 3 for damage and check continuity of wire A1592 (WP 0048 00-8). b. Repair or replace damaged wires or connectors (WP 0113 00). c. Replace damaged ECU (790) (WP 0080 00). <ol style="list-style-type: none"> a. If no voltage (24V) at X167 pin 15, check continuity of wires GY and BK going to X159 (WP 0048 00-8). b. If no voltage (24V) is found at X167 pin 14, check locking valves (6001 and 6002) soleniod harness for damage and continuity (WP 0048 00-8). c. Replace damaged or open locking valve harness. d. Notify Sustainment Maintenance to replace damaged or open X159 to X167 harness.
DIAG SERVO	11(13)													
	OUTPUT/INPUT													
FAN	0mA	0mA												
BL. VALVE	0.00V	0mA												

Table 4. Error Code 152 - Lift Cylinder Locking Valve, Component Failure Troubleshooting Procedures.

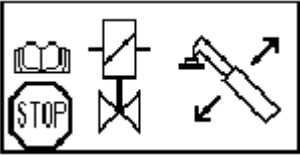
MALFUNCTION	TEST OR INSPECTION	CORRECTIVE ACTION												
<p>Error Code 152 - Lift Cylinder Locking Valve, Component Failure.</p>  <table border="1" data-bbox="305 682 602 814"> <tr> <td>DIAG SERVO</td> <td>11(13)</td> <td></td> </tr> <tr> <td></td> <td>OUTPUT/INPUT</td> <td></td> </tr> <tr> <td>FAN</td> <td>0mA</td> <td>0mA</td> </tr> <tr> <td>BL. VALVE</td> <td>0.00V</td> <td>0mA</td> </tr> </table>	DIAG SERVO	11(13)			OUTPUT/INPUT		FAN	0mA	0mA	BL. VALVE	0.00V	0mA	<ol style="list-style-type: none"> 1. Enter "DIAG SERVO" 11(13) in the diagnostic menu. Should have 24V when activating boom lowering function. 2. Disconnect the connectors from 6001 and 6002 from the lift cylinder locking valves. Check voltage between the two pins of each connector with the ignition ON. Should have voltage 24V during the lowering function. 3. Check voltage 24V at X159 pin 2 with the ignition ON. Should have 24V (WP 0048 00-8). 4. Remove the engine cover to access X167 and check voltage 24V at X167 pin 14 and 15 with the ignition ON (WP 0048 00-8). 	<p>Inspect locking valve solenoids for damage and proper connection.</p> <ol style="list-style-type: none"> a. If no voltage (24V) is found, check continuity of locking valve harness. b. If voltage (24V) is found, check resistance of locking valve solenoids (6001 and 6002). The resistance should be 18 to 20 Ohms. c. Replace damaged or shorted locking valve harness. d. Replace locking valve (WP 0252 00). <ol style="list-style-type: none"> a. If voltage (24V) is found, disconnect ECU (790) connector 2 and check pin 3 for damage and check wire A1592 for continuity to ground (WP 0048 00-8). b. Repair or replace damaged wires or connectors (WP 0113 00). c. Replace damaged ECU (790) (WP 0080 00). <ol style="list-style-type: none"> a. If no voltage (24V) is found at X167 pin 15, check wires GY and BK going to X159 for continuity to ground (WP 0048 00-8). b. If no voltage (24V) is found at X167 pin 14, check locking valves (6001 and 6002) solenoid harnesses for damage and continuity to ground (WP 0048 00-8). c. Replace damaged or shorted locking valve harness. d. Replace damaged or open X159 to X167 harness (WP 0113 00).
DIAG SERVO	11(13)													
	OUTPUT/INPUT													
FAN	0mA	0mA												
BL. VALVE	0.00V	0mA												

Table 5. Error Code 154 - Lift Cylinder Boom Up Valve, Wiring Circuit Failure Troubleshooting Procedures.

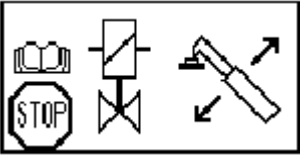
MALFUNCTION	TEST OR INSPECTION	CORRECTIVE ACTION												
<p>Error Code 154 - Lift Cylinder Boom Up Valve, Wiring Circuit Failure.</p>  <table border="1" data-bbox="297 653 599 785"> <tr> <td>DIAG SERVO</td> <td colspan="2">9 (13)</td> </tr> <tr> <td></td> <td colspan="2">OUTPUT / INPUT</td> </tr> <tr> <td>LIFT</td> <td>0mA</td> <td>0mA</td> </tr> <tr> <td>LOWER</td> <td>0mA</td> <td>0mA</td> </tr> </table>	DIAG SERVO	9 (13)			OUTPUT / INPUT		LIFT	0mA	0mA	LOWER	0mA	0mA	<ol style="list-style-type: none"> 1. Enter "DIAG SERVO" 9(13) in the diagnostic menu and activate the boom lifting function. LIFT "OUTPUT" and "INPUT" should have mA values during lifting function. 2. Check voltage at X158 between pin 1 and pin 2 with the ignition "on" (WP 0048 00-8). Should be 0V with the joystick in the neutral position and 6 to 16V during the lifting function. 3. Move the cab to the transport position (TM 10-39306-675-10). Remove the thin cover plate just in front of the cab hose tray to gain access to the servo solenoids. Check resistance of 6005 solenoid. Should be 23 to 25 Ohms. 	<ol style="list-style-type: none"> a. If no "OUTPUT" mA values display, perform troubleshooting steps for ERROR CODE 126. b. If no "INPUT" mA values display, continue with step 2. a. If voltage (16 to 24V) is found, disconnect X158 and check the resistance on the loose part of X158 between pin 1 and pin 2. Resistance should be 23 to 25 Ohms. b. If no voltage (6-16V) is found, disconnect ECU (790) connector 2 and check pin 11 for damage and check continuity of wire A1582 (WP 0048 00-8). c. Repair or replace damaged wires or connectors (WP 0113 00). d. Replace damaged ECU (790) (WP 0080 00). a. If resistance (23 to 25 Ohms) is not as specified, replace servo control valve (WP 0250 00). b. If specified resistance is found, check continuity of wires 1581 and 1582 (WP 0048 00-8). c. Notify Sustainment Maintenance to replace damaged or open harness. d. Replace ECU (790) (WP 0080 00).
DIAG SERVO	9 (13)													
	OUTPUT / INPUT													
LIFT	0mA	0mA												
LOWER	0mA	0mA												

Table 6. Error Code 155 - Lift Cylinder Boom Up Valve, Component Failure Troubleshooting Procedures.

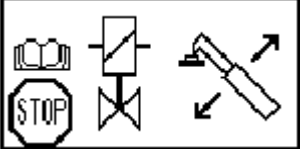
MALFUNCTION	TEST OR INSPECTION	CORRECTIVE ACTION												
<p>Error Code 155 - Lift Cylinder Boom Up Valve, Component Failure.</p>  <table border="1" data-bbox="300 682 605 814"> <tr> <td>DIAG SERVO</td> <td>9 (13)</td> <td></td> </tr> <tr> <td></td> <td>OUTPUT / INPUT</td> <td></td> </tr> <tr> <td>LIFT</td> <td>0mA</td> <td>0mA</td> </tr> <tr> <td>LOWER</td> <td>0mA</td> <td>0mA</td> </tr> </table>	DIAG SERVO	9 (13)			OUTPUT / INPUT		LIFT	0mA	0mA	LOWER	0mA	0mA	<ol style="list-style-type: none"> 1. Enter "DIAG SERVO" 9(13) in the diagnostic menu and activate the boom lifting function. LIFT "OUTPUT" and "INPUT" should have mA values during lifting function. 2. Check voltage at X158 between pin 1 and pin 2 with the ignition ON (WP 0048 00-8). Should be 0V with the joystick in the neutral position and 6 to 16V during the lifting function. 3. Move the cab to the transport position (TM 10-39306-675-10). Remove the thin cover plate just in front of the cab hose tray to gain access to the servo solenoids. Check resistance of 6005 solenoid. Should be 23 to 25 Ohms. Check solenoid for short to ground. 	<ol style="list-style-type: none"> a. If no "OUTPUT" mA values display, perform troubleshooting steps for ERROR CODE 126. b. If no "INPUT" mA values display, continue with step 2. <p style="text-align: center;">CAUTION</p> <p style="text-align: center;">Uncontrolled function may occur with this error code.</p> <ol style="list-style-type: none"> a. If voltage (16 to 24V) is found, disconnect X158 and check the resistance on the loose part of X158 between pin 1 and pin 2. Resistance should be 23 to 25 Ohms. Check continuity of each pin to ground. b. If no voltage (6 to 16V) is found, disconnect ECU (790) connector 2 and check pin 11 for damage and check continuity of wire A1582 and continuity of wire to ground (WP 0048 00-8). c. Repair or replace damaged shorted wires or connectors (WP 0113 00). d. Replace damaged ECU (790) (WP 0080 00). <ol style="list-style-type: none"> a. If resistance (23 to 25 Ohms) is not as specified or shorted to ground, replace servo control valve (WP 0250 00). b. If specified resistance is found, check continuity of wires 1581 and 1582 and check continuity of each wire to ground (WP 0048 00-8). c. Notify Sustainment Maintenance to replace damaged or open harness. d. Replace ECU (790) (WP 0080 00).
DIAG SERVO	9 (13)													
	OUTPUT / INPUT													
LIFT	0mA	0mA												
LOWER	0mA	0mA												

Table 7. Error Code 157 - Lift Cylinder Boom Down Valve, Wiring Circuit Failure Troubleshooting Procedures.

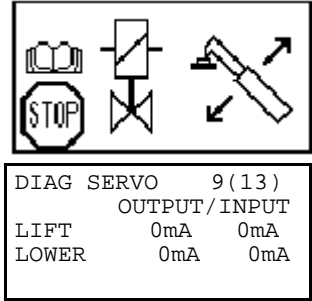
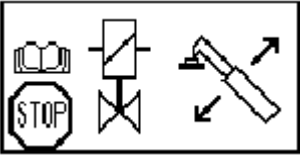
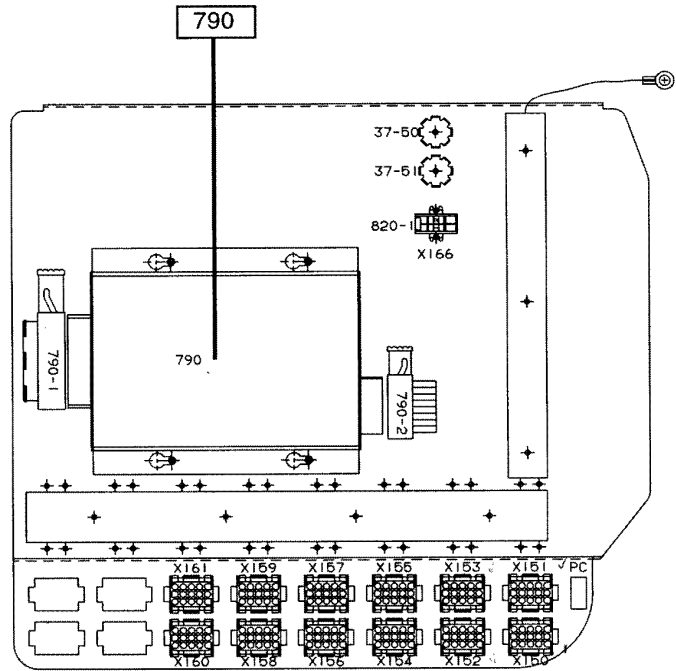
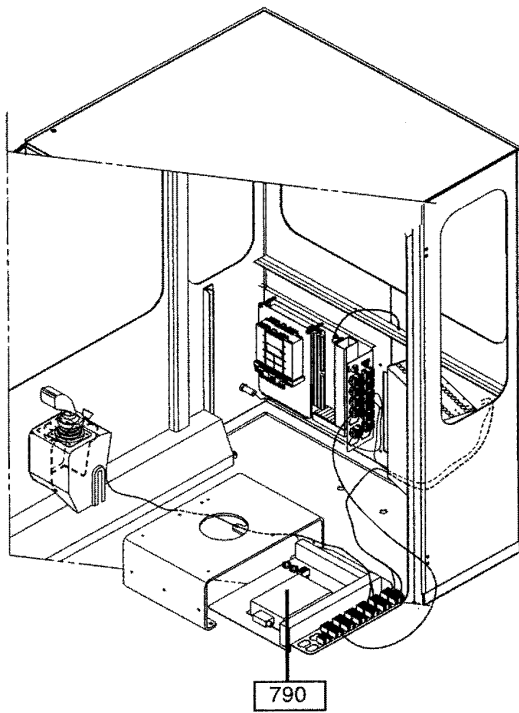
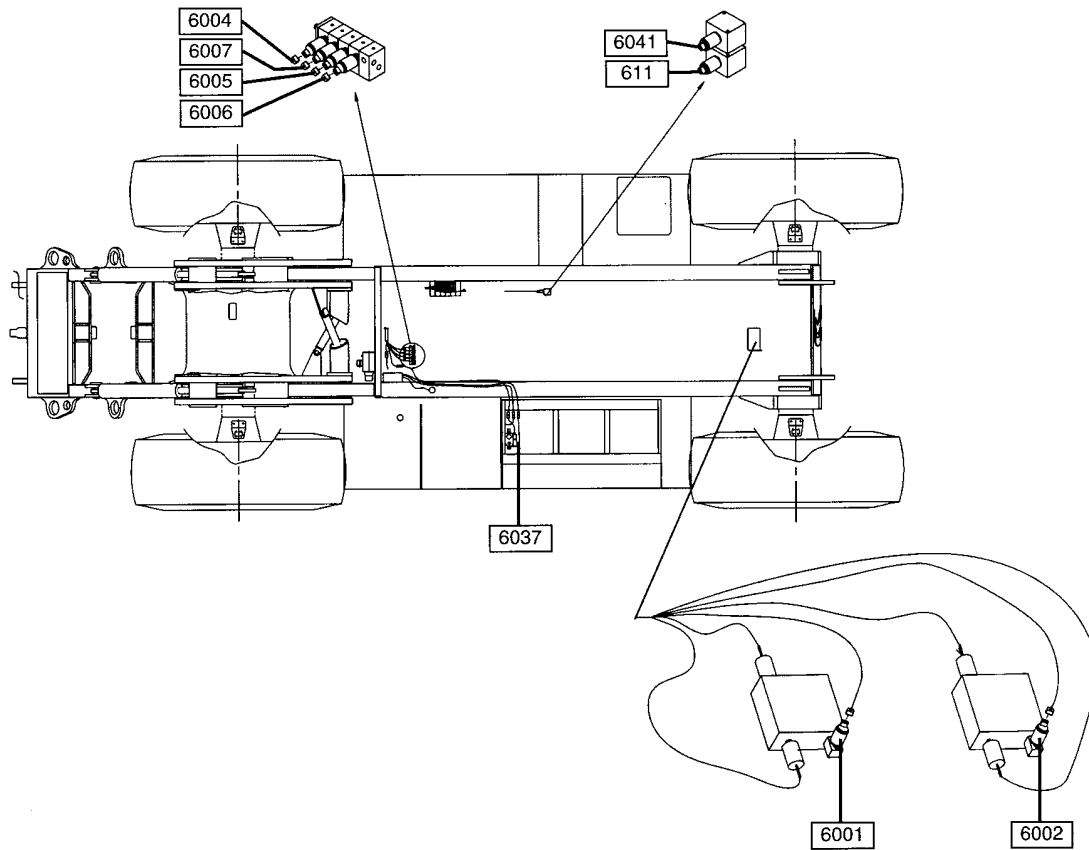
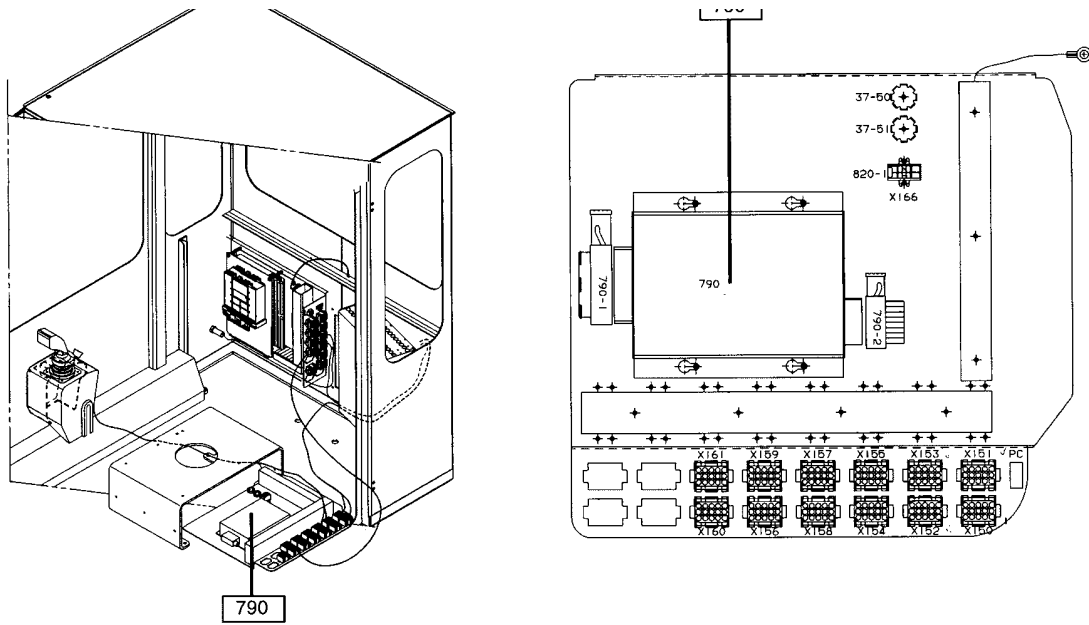
MALFUNCTION	TEST OR INSPECTION	CORRECTIVE ACTION												
<p>Error Code 157 - Lift Cylinder Boom Down Valve, Wiring Circuit Failure.</p>  <table border="1" data-bbox="293 716 602 850"> <tr> <td>DIAG SERVO</td> <td colspan="2">9 (13)</td> </tr> <tr> <td></td> <td colspan="2">OUTPUT/INPUT</td> </tr> <tr> <td>LIFT</td> <td>0mA</td> <td>0mA</td> </tr> <tr> <td>LOWER</td> <td>0mA</td> <td>0mA</td> </tr> </table>	DIAG SERVO	9 (13)			OUTPUT/INPUT		LIFT	0mA	0mA	LOWER	0mA	0mA	<ol style="list-style-type: none"> 1. Enter "DIAG SERVO" 9(13) in the diagnostic menu and activate the boom lifting function. LIFT "OUTPUT" and "INPUT" should have mA values during lifting function. 2. Check voltage at X158 between pin 3 and pin 4 with the ignition ON (WP 0048 00-8). Should be 0V with the joystick in the neutral position and 6 to 16V during the lowering function. 3. Move the cab to the transport position (TM 10-39306-675-10). Remove the thin cover plate just in front of the cab hose tray to gain access to the servo solenoids. Check resistance of 6004 solenoid. Should be 23 to 25 Ohms. 	<ol style="list-style-type: none"> a. If no "OUTPUT" mA values display, perform troubleshooting steps for ERROR CODE 126. b. If no "INPUT" mA values display, continue with step 2. a. If voltage (16 to 24V) is found, disconnect X158 and check the resistance on the loose part of X158 between pin 3 and pin 4. Resistance should be 23 to 25 Ohms. b. If no voltage (6 to 16V) is found, disconnect ECU (790) connector 2 and check pin 4 for damage and check continuity of wire A1584 (WP 0048 00-8). c. Repair or replace damaged wires or connectors (WP 0113 00). d. Replace damaged ECU (790) (WP 0080 00). a. If resistance (23 to 25 Ohms) is not as specified, replace servo control valve (WP 0250 00). b. If specified resistance is found, check continuity of wires 1583 and 1584 (WP 0048 00-8). c. Notify Sustainment Maintenance to replace damaged or open harness. d. Replace ECU (790) (WP 0080 00).
DIAG SERVO	9 (13)													
	OUTPUT/INPUT													
LIFT	0mA	0mA												
LOWER	0mA	0mA												

Table 8. Error Code 158 - Lift Cylinder Boom Down Valve, Component Failure Troubleshooting Procedures.

MALFUNCTION	TEST OR INSPECTION	CORRECTIVE ACTION												
<p>Error Code 158 - Lift Cylinder Boom Down Valve, Component Failure.</p>  <table border="1" data-bbox="297 684 602 821"> <tr> <td>DIAG SERVO</td> <td colspan="2">9 (13)</td> </tr> <tr> <td></td> <td colspan="2">OUTPUT / INPUT</td> </tr> <tr> <td>LIFT</td> <td>0mA</td> <td>0mA</td> </tr> <tr> <td>LOWER</td> <td>0mA</td> <td>0mA</td> </tr> </table>	DIAG SERVO	9 (13)			OUTPUT / INPUT		LIFT	0mA	0mA	LOWER	0mA	0mA	<ol style="list-style-type: none"> 1. Enter "DIAG SERVO" 9(13) in the diagnostic menu and activate the boom lifting function. LIFT "OUTPUT" and "INPUT" should have mA values during lifting function. 2. Check voltage at X158 between pin 3 and pin 4 with the ignition ON (WP 0048 00-8). Should be 0V with the joystick in the neutral position and 6 to 16V during the lowering function. 3. Move the cab to the transport position (TM 10-3930-675-10). Remove the thin cover plate just in front of the cab hose tray to gain access to the servo solenoids. Check resistance of 6004 solenoid. Should be 23 to 25 Ohms. Check solenoid for short to ground. 	<ol style="list-style-type: none"> a. If no "OUTPUT" mA values display, perform troubleshooting steps for ERROR CODE 126. b. If no "INPUT" mA values display, continue with step 2. <p style="text-align: center;">CAUTION</p> <p style="text-align: center;">Uncontrolled function may occur with this error code.</p> <ol style="list-style-type: none"> a. If voltage (16 to 24V) is found, disconnect X158 and check the resistance on the loose part of X158 between pin 3 and pin 4. Resistance should be 23 to 25 Ohms. Check continuity of each pin to ground. b. If no voltage (6 to 16V) is found, disconnect ECU (790) connector 2 and check continuity of wire A1584 and continuity of wire to ground (WP 0048 00-8). c. Repair or replace damaged shorted wires or connectors (WP 0113 00). d. Replace damaged ECU (790) (WP 0080 00). a. If resistance (23 to 25 Ohms) is not as specified or shorted to ground, replace servo control valve (WP 0250 00). b. If specified resistance is found, check continuity of wires 1583 and 1584 and check continuity of each wire to ground (WP 0048 00-8). c. Notify Sustainment Maintenance to replace damaged or open harness. d. Replace ECU (790) (WP 0080 00).
DIAG SERVO	9 (13)													
	OUTPUT / INPUT													
LIFT	0mA	0mA												
LOWER	0mA	0mA												



350-1034



350-1035

END OF WORK PACKAGE

BOOM IN/OUT TROUBLESHOOTING

0041 00

THIS WORK PACKAGE COVERS

Error Code 127 - Joystick-to-ECU (790) Failure
 Error Code 130 - Overload Protection System Failure
 Error Code 160 - Extension Cylinder Boom IN Control, Wiring Circuit Failure

Error Code 161 - Extension Cylinder Boom IN Control, Component Failure
 Error Code 163 - Extension Cylinder Boom OUT Control Valve, Wiring Circuit Failure
 Error Code 164 - Extension Cylinder Boom OUT Control Valve, Component Failure

INITIAL SETUP

References

- TM 10-3930-675-10
- Current Supply (A34738.0200) (WP 0048 00-31)
- ECS Electrical Servo (A34648.0200) (WP 0048 00-5)

NOTE

- Refer to WP 0004 00 for additional troubleshooting guidance, information, and illustrations that locate critical components.
- Refer also to illustrations at end of work package for component location.

Table 1. Error Code 127 - Joystick-to-ECU (790) Failure Troubleshooting Procedures.

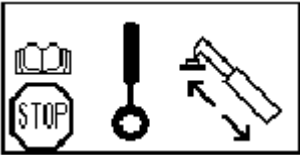
MALFUNCTION	TEST OR INSPECTION	CORRECTIVE ACTION				
<p>Error Code 127 - Joystick-to-ECU (790) Failure.</p>  <table border="1" data-bbox="282 1514 586 1640"> <tr> <td>DIAG SERVO</td> <td>5 (13)</td> </tr> <tr> <td>LIFT/LOWER BOOM IN/OUT</td> <td>5.00V</td> </tr> </table>	DIAG SERVO	5 (13)	LIFT/LOWER BOOM IN/OUT	5.00V	<ol style="list-style-type: none"> 1. Enter diagnostic menu “DIAG SERVO 5(13)” and check IN/OUT voltage. Voltage should be around 5V with no movement of the joystick. 2. Inspect ECU (790) connector <ol style="list-style-type: none"> 1. Check connector, harness and ECU (790) for damage. Check ECU tray ground wires. 	<ol style="list-style-type: none"> a. Operate the joystick extend and retract function slowly. Should have 1 to 9V over the full range of function. If the voltage suddenly goes out of range, replace joystick (WP 0082 00). b. If no voltage (5V) is found, continue with step 2. a. Repair or replace damaged wires or connectors (WP 0113 00). b. Replace damaged ECU (790) (WP 0080 00).
DIAG SERVO	5 (13)					
LIFT/LOWER BOOM IN/OUT	5.00V					

Table 1. Error Code 127 - Joystick-to-ECU (790) Failure Troubleshooting Procedures - Continued.

MALFUNCTION	TEST OR INSPECTION	CORRECTIVE ACTION
<p>Error Code 127 - Joystick-to-ECU (790) Failure - Continued.</p>	<p>3. Check voltage (10V) at X155 between pins 12 and 13 with the ignition ON (WP 0048 00-6).</p> <p>4. Check voltage (10V) at X155 between pins 2 and pin 13 with ignition ON (WP 0048 00-6). Should be around 5V.</p>	<p>a. If no voltage (10V) is found, check continuity of wires A15514A, A15514B, and A15513A (WP 0048 00-6).</p> <p>b. Repair or replace damaged wires or connectors (WP 0113 00).</p> <p>a. If no voltage (5V) is found, check continuity of wires 15512, 1552, A1552, and 15513 (WP 0048 00-6).</p> <p>b. Replace damaged or open joystick harness (WP 0083 00).</p> <p>c. Replace joystick (WP 0082 00).</p>

Table 2. Error Code 130 - Overload Protection System Failure Troubleshooting Procedures.


MALFUNCTION	TEST OR INSPECTION	CORRECTIVE ACTION
<p>Error Code 130 - Overload Protection System Failure.</p> 	<p>Overload protection system failure occurs due to an earlier failure (error codes 131 to 136) on any component related to the overload protection system. Hydraulic speeds are limited and the error code will flash on the display every 5 seconds.</p>	<p>Perform troubleshooting procedures for the original error code (error codes 131 to 136).</p>

Table 3. Error Code 160 - Extension Cylinder Boom IN Control, Wiring Circuit Failure Troubleshooting Procedures.

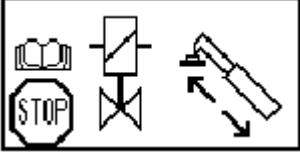
MALFUNCTION	TEST OR INSPECTION	CORRECTIVE ACTION												
<p>Error Code 160 - Extension Cylinder Boom IN Control, Wiring Circuit Failure.</p>  <table border="1" data-bbox="284 709 586 846"> <tr> <td>DIAG SERVO</td> <td>10(13)</td> <td></td> </tr> <tr> <td></td> <td>OUTPUT/INPUT</td> <td></td> </tr> <tr> <td>BOOM IN</td> <td>0mA</td> <td>0mA</td> </tr> <tr> <td>BOOM OUT</td> <td>0mA</td> <td>0mA</td> </tr> </table>	DIAG SERVO	10(13)			OUTPUT/INPUT		BOOM IN	0mA	0mA	BOOM OUT	0mA	0mA	<ol style="list-style-type: none"> 1. Enter "DIAG SERVO" 10(13) in the diagnostic menu and activate the boom in function. BOOM IN "OUTPUT" and "INPUT" should have mA values during boom in function. 2. Check voltage at X158 between pin 5 and pin 6 with the ignition ON (WP 0048 00-8). Should be 0V with the joystick in the neutral position and 6-16V during the boom IN function. 3. Move the cab to the transport position (TM 10-39306-675-10). Remove the thin cover plate just in front of the cab hose tray to gain access to the servo solenoids. Check resistance of 6007 solenoid. Should be 23 to 25 Ohms. Check solenoid for short to ground. 	<ol style="list-style-type: none"> a. If no "OUTPUT" mA values display, perform troubleshooting steps for ERROR CODE 127. b. If no "INPUT" mA values display, continue with step 2. <ol style="list-style-type: none"> a. If voltage (16 to 24V) is found, disconnect X158 and check the resistance on the loose part of X158 between pin 5 and pin 6. Resistance should be 23 to 25 Ohms. b. If no voltage (6 to 16V) is found, disconnect ECU (790) connector 2 and check pin 12 for damage and check continuity of wire A1586 (WP 0048 00-8). c. Repair or replace damaged wires or connectors (WP 0113 00). d. Replace damaged ECU (790) (WP 0080 00). <ol style="list-style-type: none"> a. If resistance (23 to 25 Ohms) is not as specified, replace servo control valve (WP 0250 00). b. If specified resistance is found, check continuity of wires 1585 and 1586 (WP 0048 00-8). c. Notify Sustainment Maintenance to replace damaged open or shorted harness. d. Replace ECU (790) (WP 0080 00).
DIAG SERVO	10(13)													
	OUTPUT/INPUT													
BOOM IN	0mA	0mA												
BOOM OUT	0mA	0mA												

Table 4. Error Code 161 - Extension Cylinder Boom IN Control, Component Failure Troubleshooting Procedures.

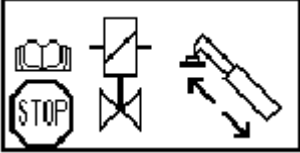
MALFUNCTION	TEST OR INSPECTION	CORRECTIVE ACTION																
<p>Error Code 161 - Extension Cylinder Boom IN Control, Component Failure.</p>  <table border="1" data-bbox="284 680 586 814"> <tr> <td>DIAG SERVO</td> <td>10(13)</td> <td></td> <td></td> </tr> <tr> <td></td> <td>OUTPUT/INPUT</td> <td></td> <td></td> </tr> <tr> <td>BOOM IN</td> <td>0mA</td> <td>0mA</td> <td></td> </tr> <tr> <td>BOOM OUT</td> <td>0mA</td> <td>0mA</td> <td></td> </tr> </table>	DIAG SERVO	10(13)				OUTPUT/INPUT			BOOM IN	0mA	0mA		BOOM OUT	0mA	0mA		<ol style="list-style-type: none"> 1. Enter "DIAG SERVO" 10(13) in the diagnostic menu and activate the boom in function. BOOM IN "OUTPUT" and "INPUT" should have mA values during boom in function. 2. Check voltage at X158 between pin 5 and pin 6 with the ignition ON (WP 0048 00-8). Should be 0V with the joystick in the neutral position and 6 to 16V during the boom IN function. 3. Move the cab to the transport position (TM 10-39306-675-10). Remove the thin cover plate just in front of the cab hose tray to gain access to the servo solenoids. Check resistance of 6007 solenoid. Should be 23 to 25 Ohms. Check solenoid for short to ground. 	<ol style="list-style-type: none"> a. If no "OUTPUT" mA values display, perform troubleshooting steps for ERROR CODE 127. b. If no "INPUT" mA values display, continue with step 2. <p style="text-align: center;">CAUTION</p> <p style="text-align: center;">Uncontrolled function may occur with this error code.</p> <ol style="list-style-type: none"> a. If voltage (16 to 24V) is found, disconnect X158 and check the resistance on the loose part of X158 between pin 5 and pin 6. Resistance should be 23 to 25 Ohms. Check continuity of each pin to ground. b. If no voltage (6 to 16V) is found, disconnect ECU (790) connector 2 and check continuity of wire A1586 and continuity of wire to ground (WP 0048 00-8). c. Repair or replace damaged, shorted wires or connectors (WP 0113 00). d. Replace damaged ECU (790) (WP 0080 00). <ol style="list-style-type: none"> a. If resistance (23 to 25 Ohms) is not as specified or shorted to ground, replace servo control valve (WP 0250 00). b. If specified resistance is found, check continuity of wires 1585 and 1586 and check continuity of each wire to ground (WP 0048 00-8). c. Notify Sustainment Maintenance to replace damaged open or shorted harness. d. Replace ECU (790) (WP 0080 00).
DIAG SERVO	10(13)																	
	OUTPUT/INPUT																	
BOOM IN	0mA	0mA																
BOOM OUT	0mA	0mA																

Table 5. Error Code 163 - Extension Cylinder Boom OUT Control Valve, Wiring Circuit Failure Troubleshooting Procedures.

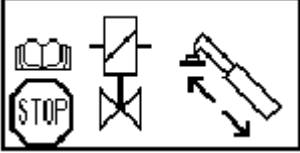
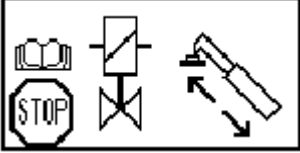
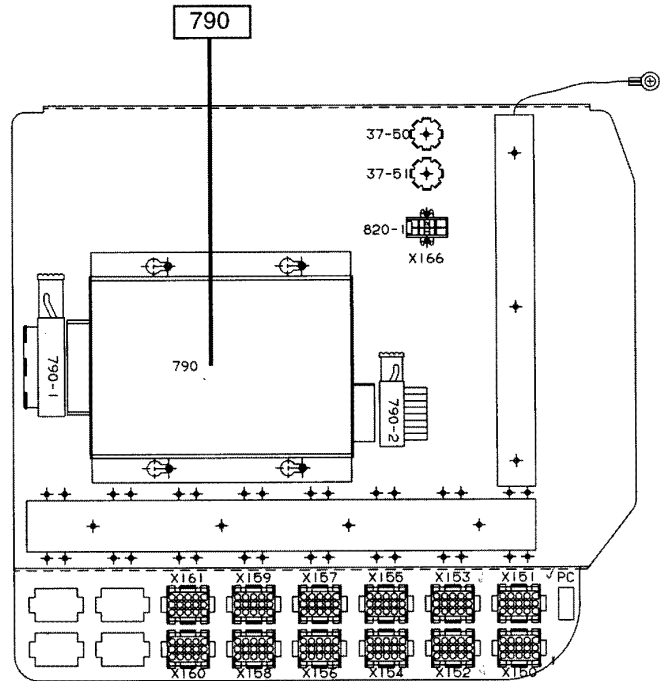
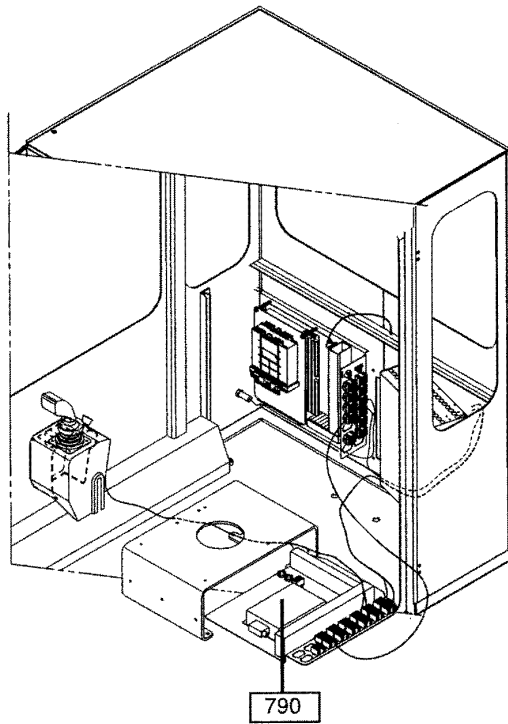
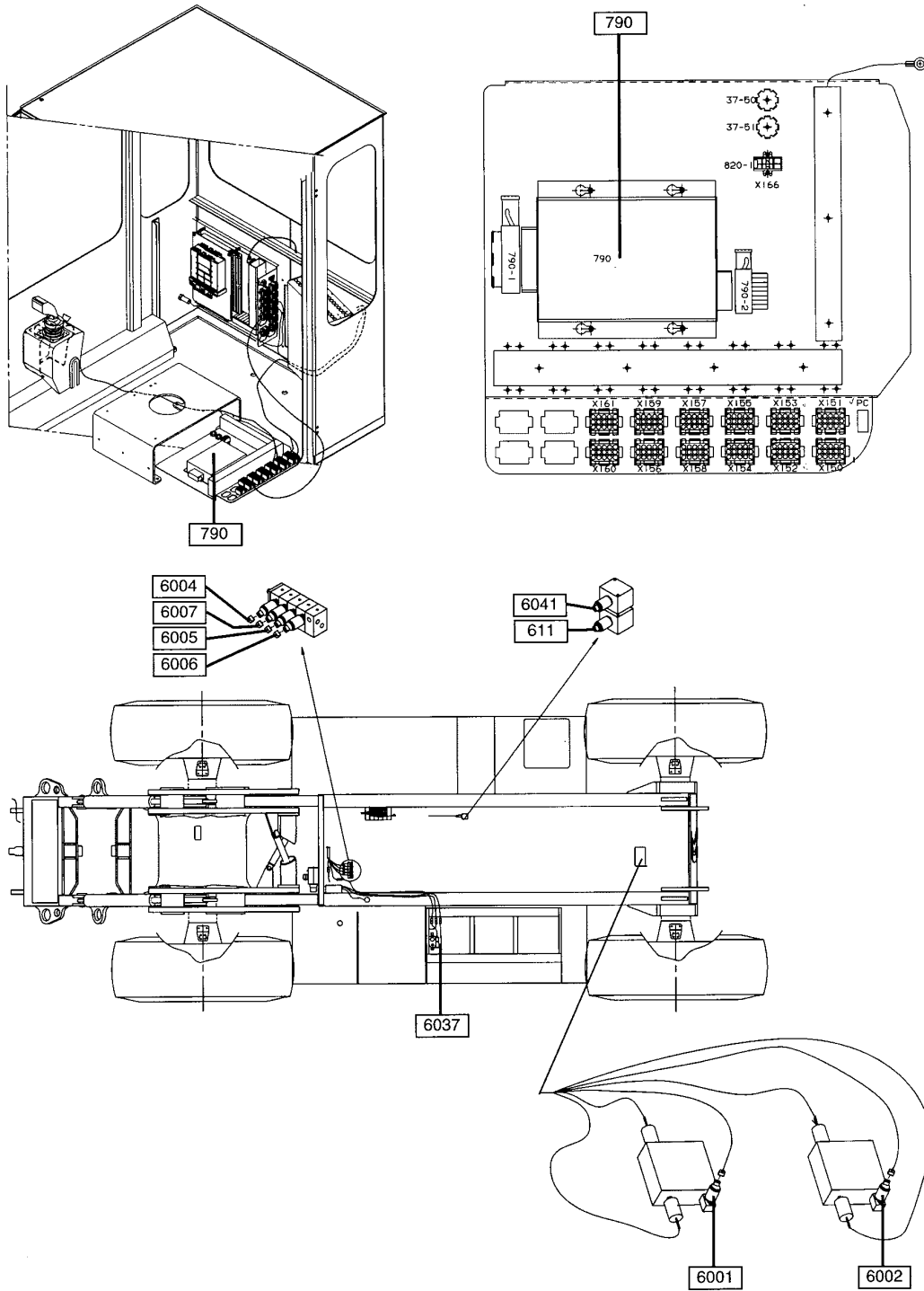
MALFUNCTION	TEST OR INSPECTION	CORRECTIVE ACTION												
<p>Error Code 163 - Extension Cylinder Boom OUT Control Valve, Wiring Circuit Failure.</p>  <table border="1" data-bbox="284 709 586 846"> <tr> <td>DIAG SERVO</td> <td>10 (13)</td> <td></td> </tr> <tr> <td>OUTPUT</td> <td></td> <td>INPUT</td> </tr> <tr> <td>BOOM IN</td> <td>0mA</td> <td>0mA</td> </tr> <tr> <td>BOOM OUT</td> <td>0mA</td> <td>0mA</td> </tr> </table>	DIAG SERVO	10 (13)		OUTPUT		INPUT	BOOM IN	0mA	0mA	BOOM OUT	0mA	0mA	<ol style="list-style-type: none"> 1. Enter "DIAG SERVO" 10(13) in the diagnostic menu and activate the boom in function. BOOM IN "OUTPUT" and "INPUT" should have mA values during boom in function. 2. Check voltage at X158 between pin 7 and pin 8 with the ignition ON (WP 0048 00-8). Should be 0V with the joystick in the neutral position and 6 to 16V during the boom OUT function. 3. Move the cab to the transport position (TM 10-39306-675-10). Remove the thin cover plate just in front of the cab hose tray to gain access to the servo solenoids. Check resistance of 6006 solenoid. Should be 23 to 25 Ohms. Check solenoid for short to ground. 	<ol style="list-style-type: none"> a. If no "OUTPUT" mA values display, perform troubleshooting steps for ERROR CODE 127. b. If no "INPUT" mA values display, continue with step 2. a. If voltage (16 to 24V) is found, disconnect X158 and check the resistance on the loose part of X158 between pin 7 and pin 8. Resistance should be 23 to 25 Ohms. b. If no voltage (6 to 16V) is found, disconnect ECU (790) connector 2 and check pin 5 for damage and check continuity of wire A1588 (WP 0048 00-8). c. Repair or replace damaged wires or connectors (WP 0113 00). d. Replace damaged ECU (790) (WP 0080 00). a. If resistance (23 to 25 Ohms) is not as specified, replace servo control valve (WP 0250 00). b. If specified resistance is found, check continuity of wires 1587 and 1588 (WP 0048 00-8). c. Notify Sustainment Maintenance to replace damaged open or shorted harness. d. Replace ECU (790) (WP 0080 00).
DIAG SERVO	10 (13)													
OUTPUT		INPUT												
BOOM IN	0mA	0mA												
BOOM OUT	0mA	0mA												

Table 6. Error Code 164 - Extension Cylinder Boom OUT Control Valve, Component Failure Troubleshooting Procedures.

MALFUNCTION	TEST OR INSPECTION	CORRECTIVE ACTION																
<p>Error Code 164 - Extension Cylinder Boom OUT Control Valve, Component Failure.</p>  <table border="1" data-bbox="284 709 586 846"> <tr> <td>DIAG SERVO</td> <td>10(13)</td> <td></td> <td></td> </tr> <tr> <td></td> <td>OUTPUT/INPUT</td> <td></td> <td></td> </tr> <tr> <td>BOOM IN</td> <td>0mA</td> <td>0mA</td> <td></td> </tr> <tr> <td>BOOM OUT</td> <td>0mA</td> <td>0mA</td> <td></td> </tr> </table>	DIAG SERVO	10(13)				OUTPUT/INPUT			BOOM IN	0mA	0mA		BOOM OUT	0mA	0mA		<ol style="list-style-type: none"> 1. Enter "DIAG SERVO" 10(13) in the diagnostic menu and activate the boom in function. BOOM IN "OUTPUT" and "INPUT" should have mA values during boom in function. 2. Check voltage at X158 between pin 7 and pin 8 with the ignition ON (WP 0048 00-8). Should be 0V with the joystick in the neutral position and 6 to 16V during the boom OUT function. 3. Move the cab to the transport position (TM 10-39306-675-10). Remove the thin cover plate just in front of the cab hose tray to gain access to the servo solenoids. Check resistance of 6006 solenoid. Should be 23 to 25 Ohms. Check Solenoid for short to ground. 	<ol style="list-style-type: none"> a. If no "OUTPUT" mA values display, perform troubleshooting steps for ERROR CODE 127. b. If no "INPUT" mA values display, continue with step 2. <p style="text-align: center;">CAUTION</p> <p style="text-align: center;">Uncontrolled function may occur with this error code.</p> <ol style="list-style-type: none"> a. If voltage (16 to 24V) is found, disconnect X158 and check the resistance on the loose part of X158 between pin 7 and pin 8. Resistance should be 23 to 25 Ohms. Check continuity of each pin to ground. b. If no voltage (6 to 16V) is found, disconnect ECU (790) connector 2 and check continuity of wire A1588 and continuity of wire to ground (WP 0048 00-8). c. Repair or replace damaged, shorted wires or connectors (WP 0113 00). d. Replace damaged ECU (790) (WP 0080 00). <ol style="list-style-type: none"> a. If resistance (23 to 25 Ohms) is not as specified or shorted to ground, replace the servo control valve (WP 0250 00). b. If specified resistance is found, check continuity of wires 1587 and 1588 and check continuity of each wire to ground (WP 0048 00-8). c. Notify Sustainment Maintenance to replace damaged open or shorted harness. d. Replace ECU (790) (WP 0080 00).
DIAG SERVO	10(13)																	
	OUTPUT/INPUT																	
BOOM IN	0mA	0mA																
BOOM OUT	0mA	0mA																



350-1034



350-1035

END OF WORK PACKAGE

THIS WORK PACKAGE COVERS

Error Code 128 - Joystick-to-ECU (790) Failure
 Error Code 130 - Overload Protection System Failure
 Error Code 255 - Tophandler Clockwise Slewing, Wiring Circuit Failure

Error Code 256 - Tophandler Clockwise Slewing, Component Failure
 Error Code 258 - Tophandler Counterclockwise Slewing, Wiring Circuit Failure
 Error Code 259 - Tophandler Counterclockwise Slewing, Component Failure

INITIAL SETUP

References

- TM 10-3930-675-10
- Current Supply (A34738.0200) (WP 0048 00-31)
- ECS Electrical Servo (A34648.0200) (WP 0048 00-5)
- ECS Attachment (A34652.0200) (WP 0048 00-23)

NOTE

- Refer to WP 0004 00 for additional troubleshooting guidance, information, and illustrations that locate critical components.
- Refer also to illustrations at end of work package for component location.

Table 1. Error Code 128 - Joystick-to-ECU (790) Failure Troubleshooting Procedures.

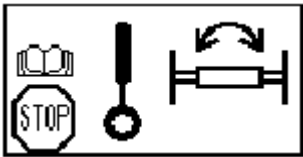
MALFUNCTION	TEST OR INSPECTION	CORRECTIVE ACTION
<p>Error Code 128 - Joystick-to-ECU (790) Failure.</p> 	<ol style="list-style-type: none"> 1. Enter diagnostic menu “DIAG SERVO 6(13)” and check SLEW CW/CCW voltage. Voltage should be around 5V with no joystick activations. 2. Inspect ECU (790) connector <ol style="list-style-type: none"> 1. Check connector, harness and ECU (790) for damage. Check ECU tray ground wires. 	<ol style="list-style-type: none"> a. Operate the joystick slewing CW and CCW function slowly. Should have 1 to 9V over the full range of function. If the voltage suddenly goes out of range, replace joystick (WP 0082 00). b. If no voltage (5V) is found, continue with step 2. a. Repair or replace damaged wires or connectors (WP 0113 00). b. Replace damaged ECU (790) (WP 0080 00).

Table 1. Error Code 128 - Joystick-to-ECU (790) Failure Troubleshooting Procedures - Continued.

MALFUNCTION	TEST OR INSPECTION	CORRECTIVE ACTION
<p>Error Code 128 - Joystick-to-ECU (790) Failure - Continued.</p>	<p>3. Check voltage (10V) at X155 between pins 12 and 13 with the ignition ON (WP 0048 00-6).</p> <p>4. Check voltage at X155 between pins 3 and 13 with the ignition ON (WP 0048 00-6). Should be around 5V.</p>	<p>a. If no voltage (10V) is found, check continuity of wires A15514A, A15514B and A15513A (WP 0048 00-6).</p> <p>b. Repair or replace damaged wires or connectors (WP 0113 00).</p> <p>a. If no voltage (5V) is found, check continuity of wires 15512, 1553, A1553A, and 15513 (WP 0048 00-6).</p> <p>b. Replace damaged or open joystick harness (WP 0083 00).</p> <p>c. Replace joystick (WP 0082 00).</p>

Table 2. Error Code 130 - Overload Protection System Failure Troubleshooting Procedures.


MALFUNCTION	TEST OR INSPECTION	CORRECTIVE ACTION
<p>Error Code 130 - Overload Protection System Failure.</p> 	<p>Overload protection system failure occurs due to an earlier failure (error codes 131 to 136) on any component related to the overload protection system. Hydraulic speeds are limited and the error code will flash on the display every 5 seconds.</p>	<p>Perform troubleshooting procedures for the original error code (error codes 131 to 136).</p>

Table 3. Error Code 255 - Tophandler Clockwise Slewing, Wiring Circuit Failure Troubleshooting Procedures.

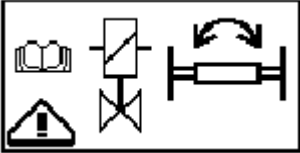
MALFUNCTION	TEST OR INSPECTION	CORRECTIVE ACTION						
<p>Error Code 255 - Tophandler Clockwise Slewing, Wiring Circuit Failure.</p>  <div style="border: 1px solid black; padding: 5px; width: fit-content;"> <p>DIAG TOP LIFT 12(16) OUTPUT/INPUT</p> <table border="0"> <tr> <td>SLEW CW</td> <td>0mA</td> <td>0mA</td> </tr> <tr> <td>SLEW CCW</td> <td>0mA</td> <td>0mA</td> </tr> </table> </div>	SLEW CW	0mA	0mA	SLEW CCW	0mA	0mA	<ol style="list-style-type: none"> 1. Check wires and connectors at tophandler control valve and tophandler junction box for damage. 2. Enter DIAG ATTACHMENT 12(16) in the diagnostic menu. Activate the CW slew function. 3. Disconnect connector 6008 from the tophandler CW slewing solenoid. Turn the ignition ON and check voltage (15 to 18V) between both pins of the connector. 4. Disconnect connector X188 from the tophandler junction box. Turn the ignition ON. Check voltage (15 to 18V) at the mounted part of the connector between pins A and B. 5. Disconnect ECU (791) connector 3. Inspect ECU and connector pins for damage. 	<ol style="list-style-type: none"> a. Repair or replace connectors (WP 0113 00). b. Replace damaged wiring harness (WP 0221 00). <p>If no INPUT mA values display; continue with troubleshooting procedure.</p> <ol style="list-style-type: none"> a. If no voltage (15 to 18V) is found, check continuity of wires 188A and 188B (WP 0048 00-27). b. If voltage (15 to 18V) is found, check resistance of 6008 solenoid. Should be 18 to 26 Ohms. c. Replace open of faulty solenoid (WP 0171 00). d. Replace X188 to solenoids wiring harness (WP 0113 00). <ol style="list-style-type: none"> a. If no voltage (15 to 18V) is found, check continuity of wires A188AA and A188B (WP 0048 00-27). b. Repair or replace damaged wires or connectors (WP 0113 00). <ol style="list-style-type: none"> a. Repair or replace damaged connector (WP 0113 00). b. Replace ECU (791) (WP 0077 00). <p style="text-align: center;">NOTE</p> <p>Multiple error codes associated with a common connector on ECU (791) may be the result of a short to ground in the harness for the common solenoid voltage. (See WP 0005 00 for troubleshooting multiple error codes.)</p>
SLEW CW	0mA	0mA						
SLEW CCW	0mA	0mA						

Table 4. Error Code 256 - Tophandler Clockwise Slewing, Component Failure Troubleshooting Procedures.

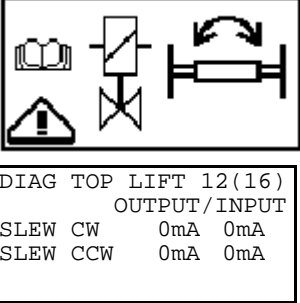
MALFUNCTION	TEST OR INSPECTION	CORRECTIVE ACTION
<p>Error Code 256 - Tophandler Clockwise Slewing, Component Failure.</p>  <p>DIAG TOP LIFT 12(16) OUTPUT/INPUT SLEW CW 0mA 0mA SLEW CCW 0mA 0mA</p>	<ol style="list-style-type: none"> 1. Check wires and connectors at tophandler control valve and tophandler junction box for damage. <p style="text-align: center;">CAUTION</p> <p style="text-align: center;">Uncontrolled function may occur with this error code.</p> <ol style="list-style-type: none"> 2. Disconnect connector 6008 from the tophandler CW slewing solenoid. Check resistance of the solenoid between both pins and between each pin and ground (WP 0048 00-27). Resistance of the solenoid should be 18 to 26 Ohms. 3. Disconnect connector X188 from tophandler junction box and disconnect solenoid 6008. Check for short to ground at loose part of X188 at pin B (wire 188B) (WP 0048 00-27). 4. Disconnect ECU (791) connector 3. Inspect ECU and connector pins for damage. Check wire A188B (pin 3) for short to ground (WP 0048 00-27). <p style="text-align: center;">NOTE</p> <p style="text-align: center;">Multiple error codes associated with a common connector on ECU (791) may be the result of a short to ground in the harness for the common solenoid voltage. (See WP 0005 00 for troubleshooting multiple error codes.)</p>	<ol style="list-style-type: none"> a. Repair or replace connectors (WP 0113 00). b. Replace damaged wiring harness (WP 0221 00). <p>Replace open or shorted solenoid (WP 0171 00).</p> <p>Replace shorted/grounded X188 to solenoid wiring harness (WP 0221 00).</p> <ol style="list-style-type: none"> a. Repair or replace shorted wires or connectors (WP 0113 00). b. Replace ECU (791) (WP 0077 00).

Table 5. Error Code 258 - Tophandler Counterclockwise Slewing, Wiring Circuit Failure Troubleshooting Procedures.

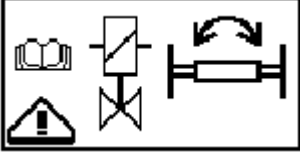
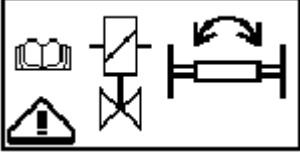
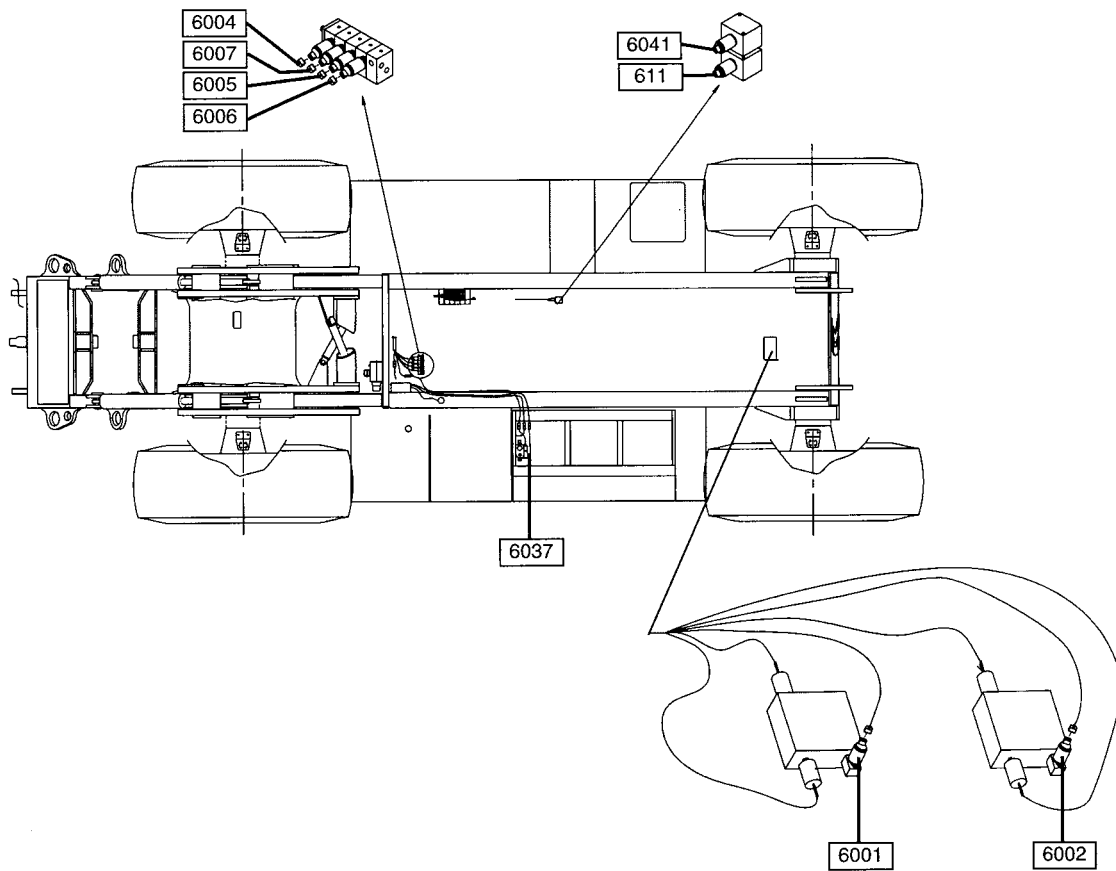
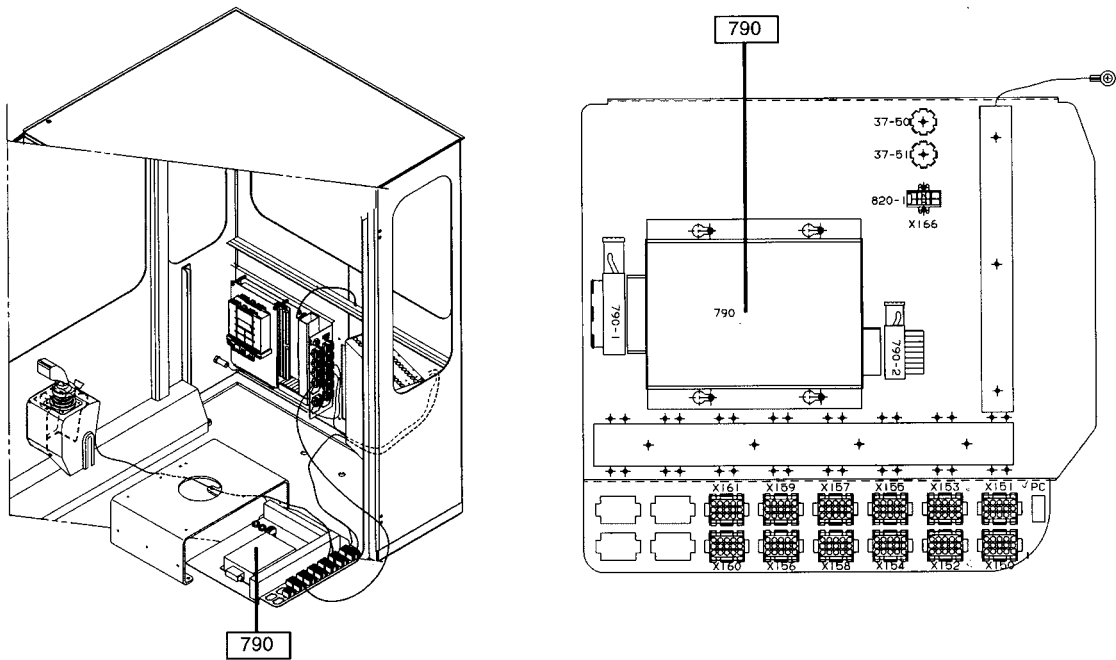
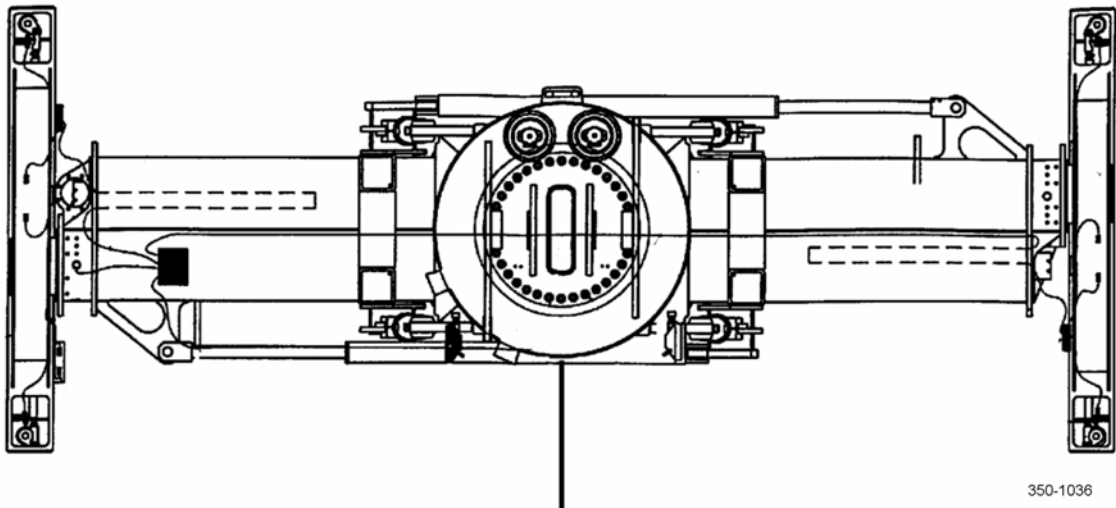
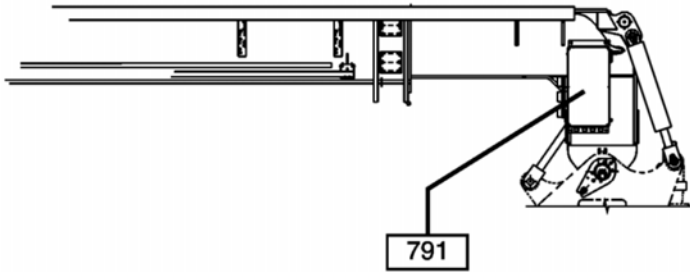
MALFUNCTION	TEST OR INSPECTION	CORRECTIVE ACTION
<p>Error Code 258 - Tophandler Counterclockwise Slewing, Wiring Circuit Failure.</p>  <div data-bbox="280 716 581 848" style="border: 1px solid black; padding: 5px;"> <p>DIAG TOP LIFT 12(16) OUTPUT/INPUT SLEW CW 0mA 0mA SLEW CCW 0mA 0mA</p> </div>	<ol style="list-style-type: none"> 1. Check wires and connectors at tophandler control valve and tophandler junction box for damage. 2. Enter DIAG ATTACHMENT 12(16) in the diagnostic menu. Activate the CCW slew function. 3. Disconnect connector 6009 from the tophandler CCW slewing solenoid. Turn the ignition ON and check voltage (15 to 18V) between both pins of the connector. 4. Disconnect connector X188 from the tophandler junction box. Turn the ignition ON. Check voltage (15 to 18V) at the mounted part of the connector between pins C and D. 5. Disconnect ECU (791) connector 3. Inspect ECU and connector pins for damage. 	<ol style="list-style-type: none"> a. Repair or replace connectors (WP 0113 00). b. Replace damaged wiring harness (WP 0221 00). <p>If no INPUT mA values display; continue with troubleshooting procedure.</p> <ol style="list-style-type: none"> a. If no voltage (15 to 18V) is found, check continuity of wires 188C and 188D (WP 0048 00-27). b. If voltage (15 to 18V) is found, check resistance of 6009 solenoid. Should be 18 to 26 Ohms. c. Replace open or faulty solenoid (WP 0171 00). d. Replace X188 to solenoids wiring harness (WP 0221 00). <ol style="list-style-type: none"> a. If no voltage (15 to 18V) is found, check continuity of wires A188AA, A188AB, and A188D (WP 0048 00-27). b. Repair or replace damaged wires or connectors (WP 0113 00). <ol style="list-style-type: none"> a. Repair or replace damaged connector (WP 0113 00). b. Replace ECU (791) (WP 0077 00). <p style="text-align: center;">NOTE</p> <p>Multiple error codes associated with a common connector on ECU (791) may be the result of a short to ground in the harness for the common solenoid voltage. (See WP 0005 00 for troubleshooting multiple error codes.)</p>

Table 6. Error Code 259 - Tophandler Counterclockwise Slewing, Component Failure Troubleshooting Procedures.

MALFUNCTION	TEST OR INSPECTION	CORRECTIVE ACTION						
<p>Error Code 259 - Tophandler Counterclockwise Slewing, Component Failure.</p>  <div data-bbox="280 716 581 848" style="border: 1px solid black; padding: 5px;"> <p>DIAG TOP LIFT 12(16) OUTPUT/INPUT</p> <table border="0"> <tr> <td>SLEW CW</td> <td>0mA</td> <td>0mA</td> </tr> <tr> <td>SLEW CCW</td> <td>0mA</td> <td>0mA</td> </tr> </table> </div>	SLEW CW	0mA	0mA	SLEW CCW	0mA	0mA	<ol style="list-style-type: none"> 1. Check wires and connectors at tophandler control valve and tophandler junction box for damage. <p style="text-align: center;">CAUTION</p> <p style="text-align: center;">Uncontrolled function may occur with this error code.</p> <ol style="list-style-type: none"> 2. Disconnect connector 6009 from the tophandler CCW slewing solenoid. Check resistance of the solenoid between both pins and between each pin and ground (WP 0048 00-27). Resistance of the solenoid should be 18 to 26 Ohms. 3. Disconnect connector X188 from the tophandler junction box and disconnect solenoid 6009. Check for short to ground at loose part of X188 at pin D (wire 188D) (WP 0048 00-27). 4. Disconnect ECU (791) connector 3. Inspect ECU and connector pins for damage. Check wire A188D (pin 11) for short to ground (WP 0048 00-27). <p style="text-align: center;">NOTE</p> <p style="text-align: center;">Multiple error codes associated with a common connector on ECU (791) may be the result of a short to ground in the harness for the common solenoid voltage. (See WP 0005 00 for troubleshooting multiple error codes.)</p>	<ol style="list-style-type: none"> a. Repair or replace connectors (WP 0113 00). b. Replace damaged wiring harness (WP 0221 00). <p>Replace open or shorted solenoid (WP 0171 00).</p> <p>Replace shorted/grounded X188 to solenoids wiring harness (WP 0221 00).</p> <ol style="list-style-type: none"> a. Repair or replace shorted wires or connectors (WP 0113 00). b. Replace ECU (791) (WP 0077 00).
SLEW CW	0mA	0mA						
SLEW CCW	0mA	0mA						



350-1035



350-1036

6009	6010	6019	6021	6035	6039	6034-1
6008	6011	6018	6020	6036	6040	

THE VALVES OF THE HYDRAULICS

END OF WORK PACKAGE

THIS WORK PACKAGE COVERS

Error Code 129 - Joystick-to-ECU (790) Failure

Error Code 130 - Overload Protection System Failure

Error Code 237 - Tophandler Tilt Locking Control, Wiring Circuit Failure

Error Code 261 - Tophandler Tilt OUT Control, Wiring Circuit Failure

Error Code 262 - Tophandler Tilt OUT Control, Component Failure

Error Code 264 - Tophandler Tilt IN Control, Wiring Circuit Failure

Error Code 265 - Tophandler Tilt IN Control, Component Failure

INITIAL SETUP

References

TM 10-3930-675-10

Current Supply (A34738.0200) (WP 0048 00-31)

ECS Electrical Servo (A34648.0200) (WP 0048 00-5)

ECS Attachment (A34652.0200) (WP 0048 00-23)

NOTE

- Refer to WP 0004 00 for additional troubleshooting guidance, information, and illustrations that locate critical components.
- Refer also to illustrations at end of work package for component location.

Table 1. Error Code 129 - Joystick-to-ECU (790) Failure Troubleshooting Procedures.

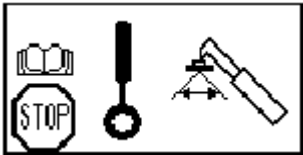
MALFUNCTION	TEST OR INSPECTION	CORRECTIVE ACTION
<p>Error Code 129 - Joystick-to-ECU (790) Failure.</p> 	<ol style="list-style-type: none"> 1. Enter diagnostic menu “DIAG SERVO 6(13)” menu and check TILT IN/OUT voltage. Voltage should be around 5V with no joystick activations. 2. Inspect ECU (790) connector <ol style="list-style-type: none"> 1. Check connector, harness and ECU (790) for damage. Check ECU tray ground wires. 	<ol style="list-style-type: none"> a. Operate the joystick tilt IN and OUT function slowly. Should have 1 to 9V over the full range of function. If the voltage suddenly goes out of range, replace joystick (WP 0082 00). b. If no voltage (5V) is found, continue with step 2. a. Repair or replace damaged wires or connectors (WP 0113 00). b. Replace damaged ECU (790) (WP 0080 00).

Table 1. Error Code 129 - Joystick-to-ECU (790) Failure Troubleshooting Procedures - Continued.

MALFUNCTION	TEST OR INSPECTION	CORRECTIVE ACTION
<p>Error Code 129 - Joystick-to-ECU (790) Failure - Continued.</p>	<p>3. Check voltage (10V) at X155 between pins 12 and 13 with the ignition ON (WP 0048 00-6).</p> <p>4. Check voltage at X155 between pins 3 and 13 with the ignition ON (WP 0048 00-6). Should be around 5V.</p>	<p>a. If no voltage (10V) is found, check continuity of wires A15514A, A15514B, and A15513A (WP 0048 00-6).</p> <p>b. Repair or replace damaged wires or connectors (WP 0113 00).</p> <p>a. If no voltage (5V) is found, check continuity of wires 15512, 1554, A1554, and 15513 (WP 0048 00-6).</p> <p>b. Replace damaged or open joystick harness (WP 0083 00).</p> <p>c. Replace joystick (WP 0082 00).</p>

Table 2. Error Code 130 - Overload Protection System Failure Troubleshooting Procedures.


MALFUNCTION	TEST OR INSPECTION	CORRECTIVE ACTION
<p>Error Code 130 - Overload Protection System Failure.</p> 	<p>Overload protection system failure occurs due to an earlier failure (error codes 131 to 136) on any component related to the overload protection system. Hydraulic speeds are limited and the error code will flash on the display every 5 seconds.</p>	<p>Perform troubleshooting procedures for the original error code (error codes 131 to 136).</p>

Table 3. Error Code 237 - Tophandler Tilt Locking Control, Wiring Circuit Failure Troubleshooting Procedures.

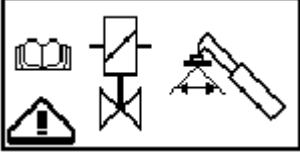
MALFUNCTION	TEST OR INSPECTION	CORRECTIVE ACTION
<p>Error Code 237 - Tophandler Tilt Locking Control, Wiring Circuit Failure.</p>  <div data-bbox="272 705 602 842" style="border: 1px solid black; padding: 5px;"> <p>DIAG ATTACHMENT 15(16) ACTIVE OUTPUT/INPUT OSC. 24.00V 900mA TILT 24.00V 900mA</p> </div>	<ol style="list-style-type: none"> 1. Check wires and connectors at moderation and tilt control valve mounted on the nose of the boom and tophandler junction box for damage. 2. Enter DIAG ATTACHMENT 15(16) in the diagnostic menu. Activate the tilt floatlock function. 3. Disconnect connector 6012-1 and 6012-2 from the tophandler tilt floatlock solenoids. Turn the ignition ON and check voltage (20 to 24V) between both pins of the connector. Check both connectors. 4. Remove the cover from the tophandler junction box. Turn the ignition ON. Check voltage (20 to 24V) at X180 between pins 14 and 15. 5. Disconnect ECU (791) connector 2. Inspect ECU and connector pins for damage. 	<ol style="list-style-type: none"> a. Repair or replace connectors (WP 0113 00). b. Replace damaged wiring harness (WP 0222 00). <p>If no INPUT mA values display or values less than 600 mA, continue with troubleshooting procedure.</p> <ol style="list-style-type: none"> a. If no voltage (20 to 24V) is found, check continuity of wires BK and GY of the solenoid harnesses (WP 0048 00-26). b. If voltage (20 to 24V) is found, check resistance of 6012-1 and 6012-2 solenoids. The top mounted solenoid should be 25 to 35 Ohms and the front mounted solenoid should be 35 to 45 Ohms. c. If solenoid is open or shorted, replace moderation and tilt control valve (WP 0263 00). d. Replace solenoid wiring harness (WP 0222 00). <ol style="list-style-type: none"> a. If no voltage (20 to 24V) is found, check continuity of wires A3018A through A3018J and A18014 (WP 0048 00-26). b. Repair or replace damaged wires or connectors (WP 0113 00). <ol style="list-style-type: none"> a. Repair or replace damaged wires or connectors (WP 0113 00). b. Replace ECU (791) (WP 0077 00). <p style="text-align: center;">NOTE</p> <p>Multiple error codes associated with a common connector on ECU (791) may be the result of a short to ground in the harness for the common solenoid voltage. (See WP 0005 00 for troubleshooting multiple error codes.)</p>

Table 4. Error Code 261 - Tophandler Tilt OUT Control, Wiring Circuit Failure Troubleshooting Procedures.

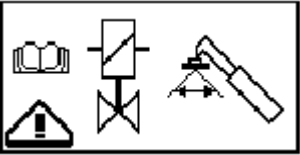
MALFUNCTION	TEST OR INSPECTION	CORRECTIVE ACTION
<p>Error Code 261 - Tophandler Tilt OUT Control, Wiring Circuit Failure.</p>  <div data-bbox="272 684 591 825" style="border: 1px solid black; padding: 5px;"> <p>DIAG ATTACHMENT 13(16) OUTPUT/INPUT TILT IN 0mA 0mA TILT OUT 0mA 0mA</p> </div>	<ol style="list-style-type: none"> 1. Check wires and connectors at tophandler control valve and tophandler junction box for damage. 2. Enter DIAG ATTACHMENT 13(16) in the diagnostic menu. Activate the tilt OUT function. 3. Disconnect connector 6010 from the tophandler tilt OUT solenoid. Turn the ignition ON and check voltage (15 to 18V) between both pins of the connector. 4. Disconnect connector X188 from the tophandler junction box. Turn the ignition ON. Check voltage (15 to 18V) at the mounted part of the connector between pins E and F. 5. Disconnect ECU (791) connector 3. Inspect ECU and connector pins for damage. 	<ol style="list-style-type: none"> a. Repair or replace connectors (WP 0113 00). b. Replace damaged wiring harness (WP 0221 00). <p>If no INPUT mA values display, continue with troubleshooting procedure.</p> <ol style="list-style-type: none"> a. If no voltage (15 to 18V) is found, check continuity of wires 188E and 188F (WP 0048 00-27). b. If voltage (15 to 18V) is found, check resistance of 6010 solenoid. Should be 18 to 26 Ohms. c. Replace open of faulty solenoid (WP 0171 00). d. Replace X188 to solenoids wiring harness (WP 0221 00). <ol style="list-style-type: none"> a. If no voltage (15 to 18V) is found, check continuity of wires A188AA, A188AB, A188AC, and A188F (WP 0048 00-27). b. Repair or replace damaged wires or connectors (WP 0113 00). <ol style="list-style-type: none"> a. Repair or replace damaged connector (WP 0113 00). b. Replace ECU (791) (WP 0077 00). <p style="text-align: center;">NOTE</p> <p>Multiple error codes associated with a common connector on ECU (791) may be the result of a short to ground in the harness for the common solenoid voltage. (See WP 0005 00 for troubleshooting multiple error codes.)</p>

Table 5. Error Code 262 - Tophandler Tilt OUT Control, Component Failure Troubleshooting Procedures.

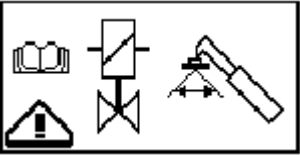
MALFUNCTION	TEST OR INSPECTION	CORRECTIVE ACTION												
<p>Error Code 262 - Tophandler Tilt OUT Control, Component Failure.</p>  <table border="1" data-bbox="269 688 597 825"> <tr> <td colspan="3">DIAG ATTACHMENT 13 (16)</td> </tr> <tr> <td></td> <td colspan="2">OUTPUT/INPUT</td> </tr> <tr> <td>TILT IN</td> <td>0mA</td> <td>0mA</td> </tr> <tr> <td>TILT OUT</td> <td>0mA</td> <td>0mA</td> </tr> </table>	DIAG ATTACHMENT 13 (16)				OUTPUT/INPUT		TILT IN	0mA	0mA	TILT OUT	0mA	0mA	<ol style="list-style-type: none"> 1. Check wires and connectors at tophandler control valve and tophandler junction box for damage. 2. Disconnect connector 6010 from the tophandler tilt OUT solenoid. Check resistance of the solenoid between both pins and between each pin and ground (WP 0048 00-27). Resistance of the solenoid should be 18 to 26 Ohms. 3. Disconnect connector X188 from tophandler junction box and disconnect solenoid 6010. Check for short to ground at loose part of X188 at pin F (wire 188F) (WP 0048 00-27). 4. Disconnect ECU (791) connector 3. Inspect ECU and connector pins for damage. Check wire A188F (pin 4) for short to ground (WP 0048 00-27). 	<ol style="list-style-type: none"> a. Repair or replace connectors (WP 0113 00). b. Replace damaged wiring harness (WP 0221 00). <p style="text-align: center;">CAUTION</p> <p style="text-align: center;">Uncontrolled function may occur with this error code.</p> <ol style="list-style-type: none"> Replace open or shorted solenoid (WP 0171 00). Replace open or shorted/grounded X188 to solenoids wiring harness (WP 0221 00). a. Repair or replace shorted wires or connectors (WP 0113 00). b. Replace ECU (791) (WP 0077 00). <p style="text-align: center;">NOTE</p> <p style="text-align: center;">Multiple error codes associated with a common connector on ECU (791) may be the result of a short to ground in the harness for the common solenoid voltage. (See WP 0005 00 for troubleshooting multiple error codes.)</p>
DIAG ATTACHMENT 13 (16)														
	OUTPUT/INPUT													
TILT IN	0mA	0mA												
TILT OUT	0mA	0mA												

Table 6. Error Code 264 - Tophandler Tilt IN Control, Wiring Circuit Failure Troubleshooting Procedures.

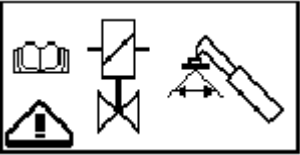
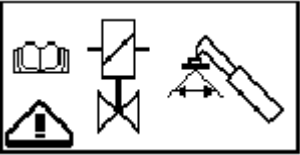
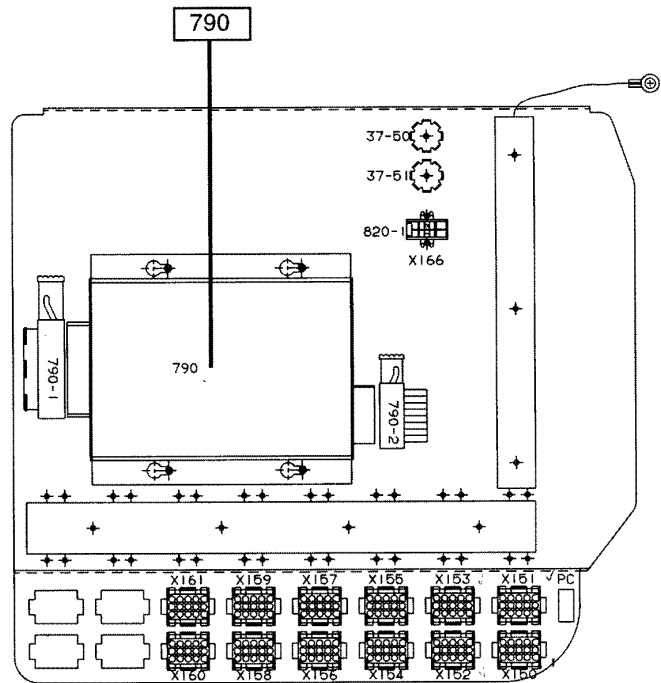
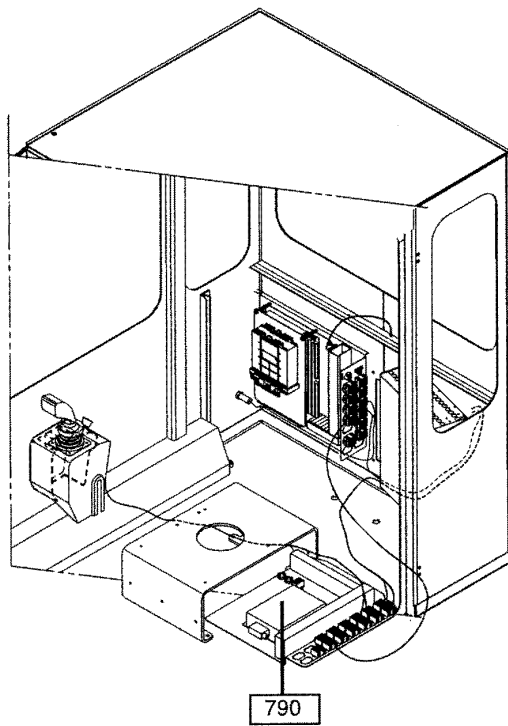
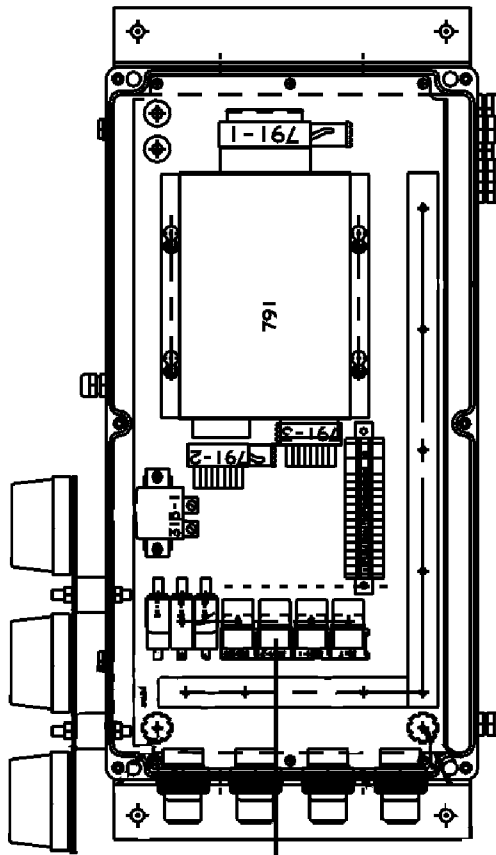
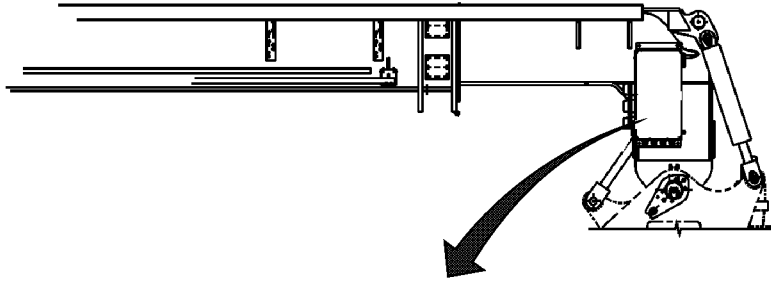
MALFUNCTION	TEST OR INSPECTION	CORRECTIVE ACTION
<p>Error Code 264 - Tophandler Tilt IN Control, Wiring Circuit Failure.</p>  <div data-bbox="276 688 594 825" style="border: 1px solid black; padding: 5px;"> <p>DIAG ATTACHMENT 13(16) OUTPUT/INPUT TILT IN 0mA 0mA TILT OUT 0mA 0mA</p> </div>	<ol style="list-style-type: none"> 1. Check wires and connectors at tophandler control valve and tophandler junction box for damage. 2. Enter DIAG ATTACHMENT 13(16) in the diagnostic menu. Activate the tilt IN function. 3. Disconnect connector 6011 from the tophandler tilt IN solenoid. Turn the ignition ON and check voltage (15 to 18V) between both pins of the connector. 4. Disconnect connector X188 from the tophandler junction box. Turn the ignition ON. Check voltage (15 to 18V) at the mounted part of the connector between pins G and H. 5. Disconnect ECU (791) connector 3. Inspect ECU and connector pins for damage. <p style="text-align: center;">NOTE</p> <p>Multiple error codes associated with a common connector on ECU (791) may be the result of a short to ground in the harness for the common solenoid voltage. (See WP 0005 00 for troubleshooting multiple error codes.)</p>	<ol style="list-style-type: none"> a. Repair or replace connectors (WP 0113 00). b. Replace damaged wiring harness (WP 0221 00). <p>If no INPUT mA values display, continue with troubleshooting procedure.</p> <ol style="list-style-type: none"> a. If no voltage (15 to 18V) is found, check continuity of wires 188G and 188H (WP 0048 00-27). b. If voltage (15 to 18V) is found, check resistance of 6011 solenoid. Should be 18 to 26 Ohms. c. Replace open or faulty solenoid (WP 0171 00). d. Replace X188 to solenoids wiring harness (WP 0221 00). <ol style="list-style-type: none"> a. If no voltage (15 to 18V) is found, check continuity of wires A188AA, A188AB, A188AC, A188AD, and A188H (WP 0048 00-27). b. Repair or replace damaged wires or connectors (WP 0113 00). <ol style="list-style-type: none"> a. Repair or replace damaged connector (WP 0113 00). b. Replace ECU (791) (WP 0077 00).

Table 7. Error Code 265 - Tophandler Tilt IN Control, Component Failure Troubleshooting Procedures.

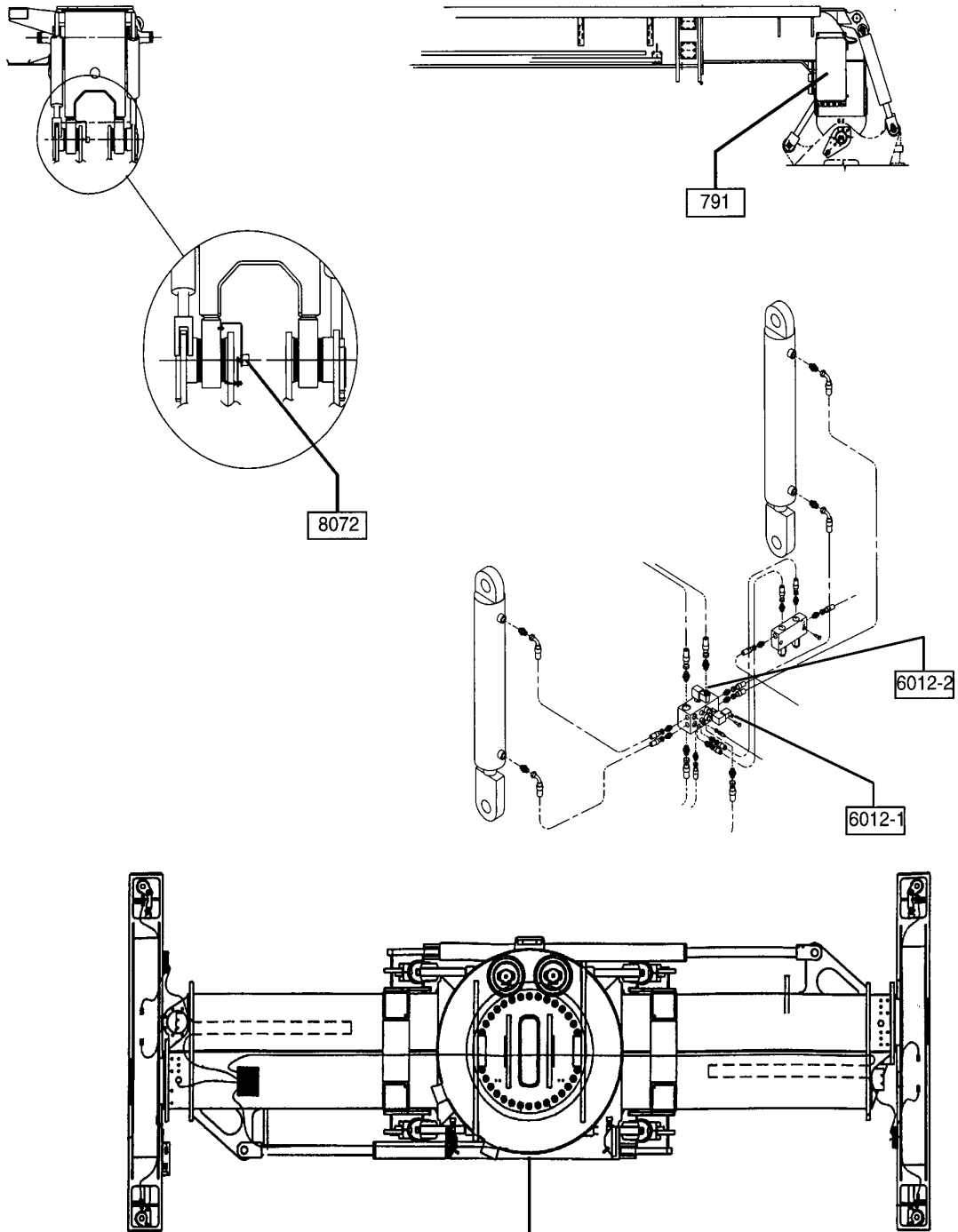
MALFUNCTION	TEST OR INSPECTION	CORRECTIVE ACTION
<p>Error Code 265 - Tophandler Tilt IN Control, Component Failure.</p>  <div style="border: 1px solid black; padding: 5px; margin-top: 10px;"> <p>DIAG ATTACHMENT 13(16) OUTPUT/INPUT TILT IN 0mA 0mA TILT OUT 0mA 0mA</p> </div>	<ol style="list-style-type: none"> 1. Check wires and connectors at tophandler control valve and tophandler junction box for damage. <p style="text-align: center;">CAUTION</p> <p style="text-align: center;">Uncontrolled function may occur with this error code.</p> <ol style="list-style-type: none"> 2. Disconnect connector 6011 from the tophandler tilt IN solenoid. Check resistance of the solenoid between both pins and between each pin and ground (WP 0048 00-27). Resistance of the solenoid should be 18 to 26 Ohms 3. Disconnect connector X188 from tophandler junction box and disconnect solenoid 6011. Check for short to ground at loose part of X188 at pin H (wire 188H) (WP 0048 00-27). 4. Disconnect ECU (791) connector 3. Inspect ECU and connector pins for damage. Check wire A188H (pin 12) for short to ground (WP 0048 00-27). <p style="text-align: center;">NOTE</p> <p style="text-align: center;">Multiple error codes associated with a common connector on ECU (791) may be the result of a short to ground in the harness for the common solenoid voltage. (See WP 0005 00 for troubleshooting multiple error codes.)</p>	<ol style="list-style-type: none"> a. Repair or replace connectors (WP 0113 00). b. Replace damaged wiring harness (WP 0221 00). <p>Replace open or shorted solenoid (WP 0171 00).</p> <p>Replace shorted/grounded X188 to solenoids wiring harness (WP 0221 00).</p> <ol style="list-style-type: none"> a. Repair or replace shorted wires or connectors (WP 0113 00). b. Replace ECU (791) (WP 0077 00).



350-1034



350-1342



6009	6010	6019	6021	6035	6039	6034-1
6008	6011	6018	6020	6036	6040	6034-2

THE VALVES OF THE HYDRAULICS

END OF WORK PACKAGE

THIS WORK PACKAGE COVERS

Error Code 128 - Joystick-to-ECU (790) Failure

Error Code 130 - Overload Protection System Failure

Error Code 240 - Tophandler Leveling Locking Control, Wiring Circuit Failure

Error Code 267 - Tophandler Leveling Right, Open Circuit Failure

Error Code 268 - Tophandler Leveling Right, Short Circuit Failure

Error Code 270 - Tophandler Leveling Left, Open Circuit Failure

Error Code 271 - Tophandler Leveling Left, Short Circuit Failure

INITIAL SETUP

References

TM 10-3930-675-10

Current Supply (A34738.0200) (WP 0048 00-31)

References - Continued

ECS Electrical Servo (A34648.0200) (WP 0048 00-5)

ECS Attachment (A34652.0200) (WP 0048 00-23)

NOTE

- Refer to WP 0004 00 for additional troubleshooting guidance, information, and illustrations that locate critical components.
- Refer also to illustrations at end of work package for component location.

Table 1. Error Code 128 - Joystick-to-ECU (790) Failure Troubleshooting Procedures.

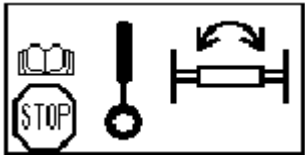
MALFUNCTION	TEST OR INSPECTION	CORRECTIVE ACTION
<p>Error Code 128 - Joystick-to-ECU (790) Failure.</p> 	<ol style="list-style-type: none"> 1. Enter diagnostic menu “DIAG SERVO 6(13)” and check SLEW CW/CCW voltage. Voltage should be around 5V with no joystick activations. 2. Inspect ECU (790) connector <ol style="list-style-type: none"> 1. Check connector, harness, and ECU (790) for damage. Check ECU tray ground wires. 	<ol style="list-style-type: none"> a. Operate the joystick slewing CW and CCW function slowly. Should have 1 to 9V over the full range of function. If the voltage suddenly goes out of range, replace joystick (WP 0082 00). b. If no voltage (5V) is found, continue with step 2. <ol style="list-style-type: none"> a. Repair or replace damaged wires or connectors (WP 0113 00). b. Replace damaged ECU (790) (WP 0080 00).

Table 1. Error Code 128 - Joystick-to-ECU (790) Failure Troubleshooting Procedures - Continued.

MALFUNCTION	TEST OR INSPECTION	CORRECTIVE ACTION
<p>Error Code 128 - Joystick-to-ECU (790) Failure - Continued.</p>	<p>3. Check voltage (10V) at X155 between pins 12 and 13 with the ignition ON (WP 0048 00-6).</p> <p>4. Check voltage at X155 between pins 3 and 13 with the ignition ON (WP 0048 00-6). Should be around 5V.</p>	<p>a. If no voltage (10V) is found, check continuity of wires A15514A, A15514B, and A15513A (WP 0048 00-6).</p> <p>b. Repair or replace damaged wires or connectors (WP 0113 00).</p> <p>a. If no voltage (5V) is found, check continuity of wires 15512, 1553, A1553A, and 15513 (WP 0048 00-6).</p> <p>b. Replace damaged or open joystick harness (WP 0083 00).</p> <p>5. Replace joystick (WP 0082 00).</p>

Table 2. Error Code 130 - Overload Protection System Failure Troubleshooting Procedures.


MALFUNCTION	TEST OR INSPECTION	CORRECTIVE ACTION
<p>Error Code 130 - Overload Protection System Failure.</p> 	<p>Overload protection system failure occurs due to an earlier failure (error codes 131 to 136) on any component related to the overload protection system. Hydraulic speeds are limited and the error code will flash on the display every 5 seconds.</p>	<p>Perform troubleshooting procedures for the original error code (error codes 131 to 136).</p>

Table 3. Error Code 240 - Tophandler Leveling Locking Control, Wiring Circuit Failure Troubleshooting Procedures.

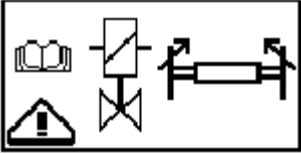
MALFUNCTION	TEST OR INSPECTION	CORRECTIVE ACTION
<p>Error Code 240 - Tophandler Leveling Locking Control, Wiring Circuit Failure.</p>  <div data-bbox="284 703 609 840" style="border: 1px solid black; padding: 5px;"> <p>DIAG ATTACHMENT 15(16) ACTIVE OUTPUT/INPUT OSC. 24.00V 900mA TILT 24.00V 900mA</p> </div>	<ol style="list-style-type: none"> 1. Check wires and connectors at leveling floatlock control valve mounted at the right of the tophandler control valve and tophandler junction box for damage. 2. Enter DIAG ATTACHMENT 15(16) in the diagnostic menu. Activate the leveling floatlock function. 3. Disconnect connector 6034-1 and 6034-2 from the tophandler leveling floatlock solenoids. Turn the ignition ON and check voltage (20 to 24V) between both pins of the connector. Check both connectors. 4. Disconnect connector X188 and X189 from the tophandler junction box. Turn the ignition ON. Check voltage (20 to 24V) at the mounted part of the connector between pins N and P. Check both connectors. 5. Disconnect ECU (791) connector 2. Inspect ECU and connector pins for damage. <p style="text-align: center;">NOTE</p> <p>Multiple error codes associated with a common connector on ECU (791) may be the result of a short to ground in the harness for the common solenoid voltage. (See WP 0005 00 for troubleshooting multiple error codes.)</p>	<ol style="list-style-type: none"> a. Repair or replace connectors (WP 0113 00). b. Replace damaged wiring harnesses to solenoids wiring harness (WP 0221 00). <p>If no INPUT mA values display, continue with troubleshooting procedure.</p> <ol style="list-style-type: none"> a. If no voltage (20 to 24V) is found, check continuity of wires 188N and 188P, 189N, and 189P (WP 0048 00-26). b. If voltage (20 to 24V) found, check resistance of 6034-1 and 6034-2 solenoids. The solenoids should be 40 to 50 Ohms. c. If solenoid is open or shorted, replace leveling floatlock control valve (WP 0263 00). d. Replace X188 or X189 wiring harness to solenoids wiring harness (WP 0221 00). <ol style="list-style-type: none"> a. If no voltage (20 to 24V) is found, check continuity of wires A3018A through A3018I, A189P, and A188P (0048 00-26). b. Repair or replace damaged wires or connectors (WP 0113 00). <ol style="list-style-type: none"> a. Repair or replace damaged connector (WP 0113 00). b. Replace ECU (791) (WP 0077 00).

Table 4. Error Code 267 - Tophandler Leveling Right, Open Circuit Failure Troubleshooting Procedures.

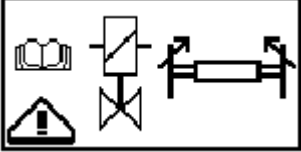
MALFUNCTION	TEST OR INSPECTION	CORRECTIVE ACTION
<p>Error Code 267 - Tophandler Leveling Right, Open Circuit Failure.</p>  <p>DIAG ATTACHMENT 14(16) OSC, RI OSC, LE</p>	<ol style="list-style-type: none"> 1. Check wires and connectors at tophandler control valve and tophandler junction box for damage. 2. Enter DIAG ATTACHMENT 14(16) in the diagnostic menu. Activate the leveling right function. 3. Disconnect connector 6035 from the tophandler tophandler leveling right solenoid. Turn the ignition ON and check voltage (15 to 18V) between both pins of the connector. 4. Disconnect connector X189 from the tophandler junction box. Turn the ignition ON. Check voltage (15 to 18V) at the mounted part of the connector between pins E and F. 5. Disconnect ECU (791) connector 3. Inspect ECU and connector pins for damage. 	<ol style="list-style-type: none"> a. Repair or replace connectors (WP 0113 00). b. Replace damaged wiring harness (WP 0221 00). <p>If no INPUT mA values display, continue with troubleshooting procedure.</p> <ol style="list-style-type: none"> a. If no voltage (15-18V) is found, check continuity of wires 189E and 189F (WP 0048 00-27). b. If voltage (15-18V) is found, check resistance of 6035 solenoid. Should be 18 to 26 Ohms. c. Replace open or faulty solenoid (WP 0171 00). d. Replace X189 to solenoids wiring harness (WP 0221 00). <ol style="list-style-type: none"> a. If no voltage (15 to 18V) is found, check continuity of wires A188AA through A188AE, and A189F (WP 0048 00-27). b. Repair or replace damaged wires or connectors (WP 0221 00). <ol style="list-style-type: none"> a. Repair or replace damaged connector (WP 0113 00). b. Replace ECU (791) (WP 0077 00). <p style="text-align: center;">NOTE</p> <p>Multiple error codes associated with a common connector on ECU (791) may be the result of a short to ground in the harness for the common solenoid voltage. (See WP 0005 00 for troubleshooting multiple error codes.)</p>

Table 5. Error Code 268 - Tophandler Leveling Right, Short Circuit Failure Troubleshooting Procedures.

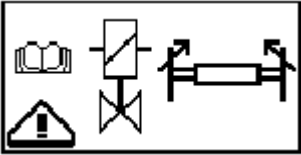
MALFUNCTION	TEST OR INSPECTION	CORRECTIVE ACTION
<p>Error Code 268 - Tophandler Leveling Right, Short Circuit Failure.</p>  <p>DIAG ATTACHMENT 14 (16) OSC, RI OSC, LE</p>	<ol style="list-style-type: none"> 1. Check wires and cables from tophandler junction box for damage. 2. Disconnect connector 6035 from the tophandler leveling right solenoid. Check resistance of the solenoid between both pins and between each pin and ground (WP 0048 00-27). Resistance of the solenoid should be 18 to 26 Ohms. 3. Disconnect connector X189 from the tophandler junction box and disconnect solenoid 6035. Check for short to ground at loose part of X189 at pin F (wire 189F) (WP 0048 00-27). 4. Disconnect ECU (791) connector 3. Inspect ECU and connector pins for damage. Check wire A189F (pin 5) for short to ground (WP 0048 00-27). 	<ol style="list-style-type: none"> a. Repair or replace connectors (WP 0113 00). b. Replace damaged wiring harness (WP 0221 00). <p style="text-align: center;">CAUTION</p> <p style="text-align: center;">Uncontrolled function may occur with this error code.</p> <ol style="list-style-type: none"> Replace open or shorted solenoid (WP 0171 00). c. Replace shorted/grounded X189 to solenoids wiring harness (WP 0221 00). a. Repair or replace shorted wires or connectors (WP 0113 00). b. Replace ECU (791) (WP 0077 00). <p style="text-align: center;">NOTE</p> <p style="text-align: center;">Multiple error codes associated with a common connector on ECU (791) may be the result of a short to ground in the harness for the common solenoid voltage. (See WP 0005 00 for troubleshooting multiple error codes.)</p>

Table 6. Error Code 270 - Tophandler Leveling Left, Open Circuit Failure Troubleshooting Procedures.

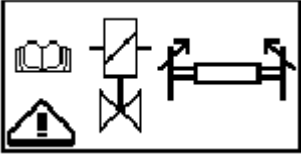
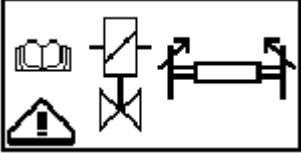
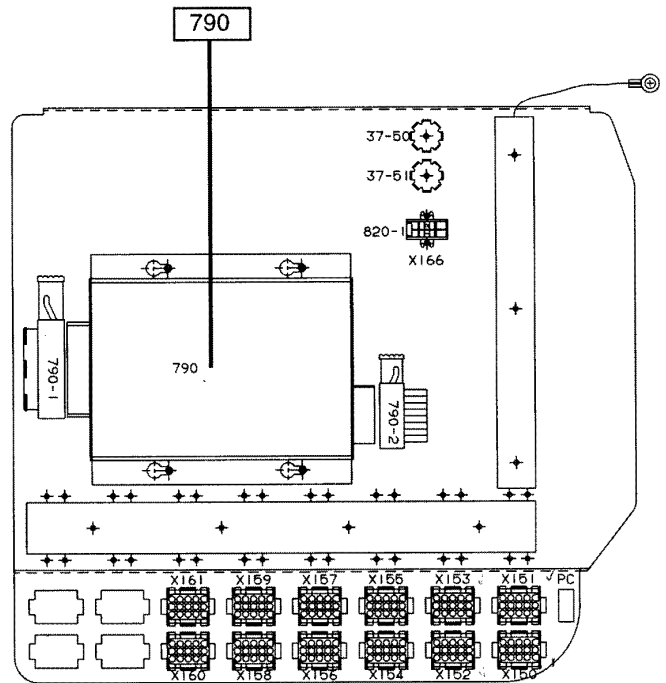
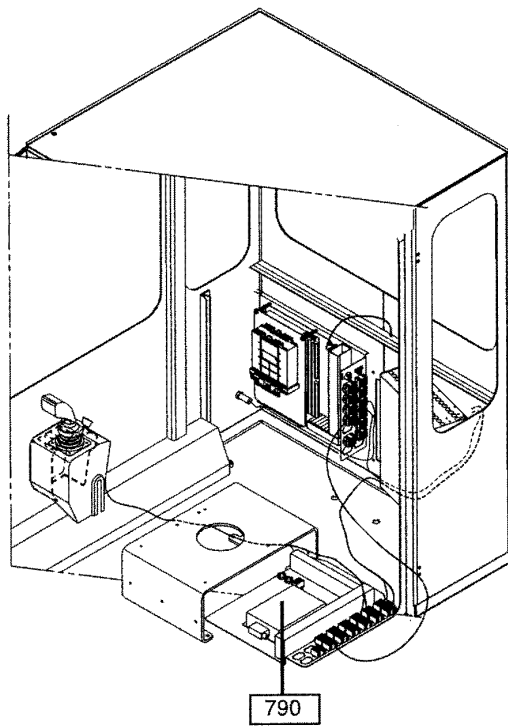
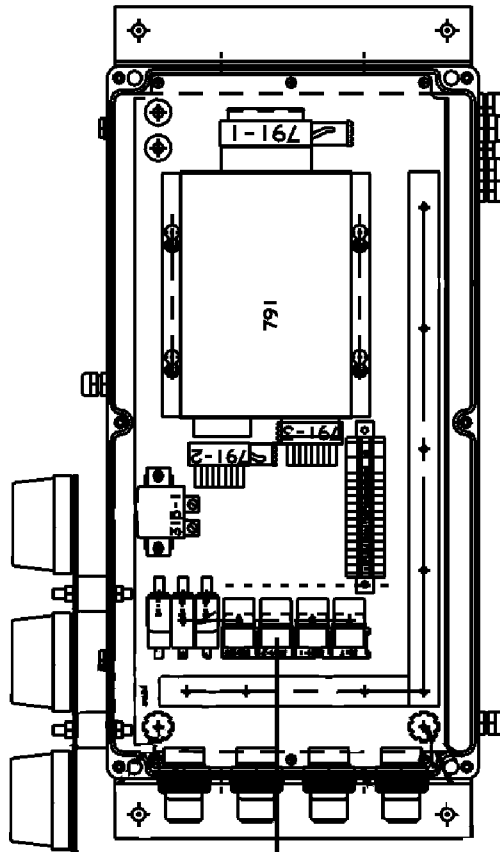
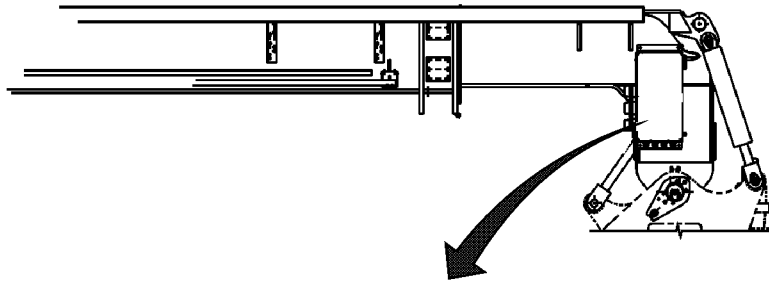
MALFUNCTION	TEST OR INSPECTION	CORRECTIVE ACTION
<p>Error Code 270 - Tophandler Leveling Left, Open Circuit Failure.</p>  <p>DIAG ATTACHMENT 14(16) OSC, RI OSC, LE</p>	<ol style="list-style-type: none"> 1. Check wires and connectors at tophandler control valve and tophandler junction box for damage. 2. Enter DIAG ATTACHMENT 14(16) in the diagnostic menu. Activate the leveling left function. 3. Disconnect connector 6036 from the tophandler leveling left solenoid. Turn the ignition ON and check voltage (15 to 18V) between both pins of the connector. 4. Disconnect connector X189 from the tophandler junction box. Turn the ignition ON. Check voltage (15 to 18V) at the mounted part of the connector between pins G and H. 5. Disconnect ECU (791) connector 3. Inspect ECU and connector pins for damage. 	<ol style="list-style-type: none"> a. Repair or replace connectors (WP 0113 00). b. Replace damaged wiring harness (WP 0221 00). <p>If no INPUT mA values display, continue with troubleshooting procedure.</p> <ol style="list-style-type: none"> a. If no voltage (15 to 18V) is found, check continuity of wires 189G and 189H (WP 0048 00-27). b. If voltage (15 to 18V) is found, check resistance of 6036 solenoid. Resistance should be 18 to 26 Ohms. c. Replace open or faulty solenoid (WP 0171 00). d. Replace X189 to solenoids wiring harness (WP 0221 00). <ol style="list-style-type: none"> a. If no voltage (15 to 18V) is found, check continuity of wires A188AA through A188AF and A189H (WP 0048 00-27). b. Repair or replace damaged wires or connectors (WP 0113 00). <ol style="list-style-type: none"> a. Repair or replace damaged connector (WP 0113 00). b. Replace ECU (791) (WP 0077 00). <p style="text-align: center;">NOTE</p> <p>Multiple error codes associated with a common connector on ECU (791) may be the result of a short to ground in the harness for the common solenoid voltage. (See WP 0005 00 for troubleshooting multiple error codes.)</p>

Table 7. Error Code 271 - Tophandler Leveling Left, Short Circuit Failure Troubleshooting Procedures.

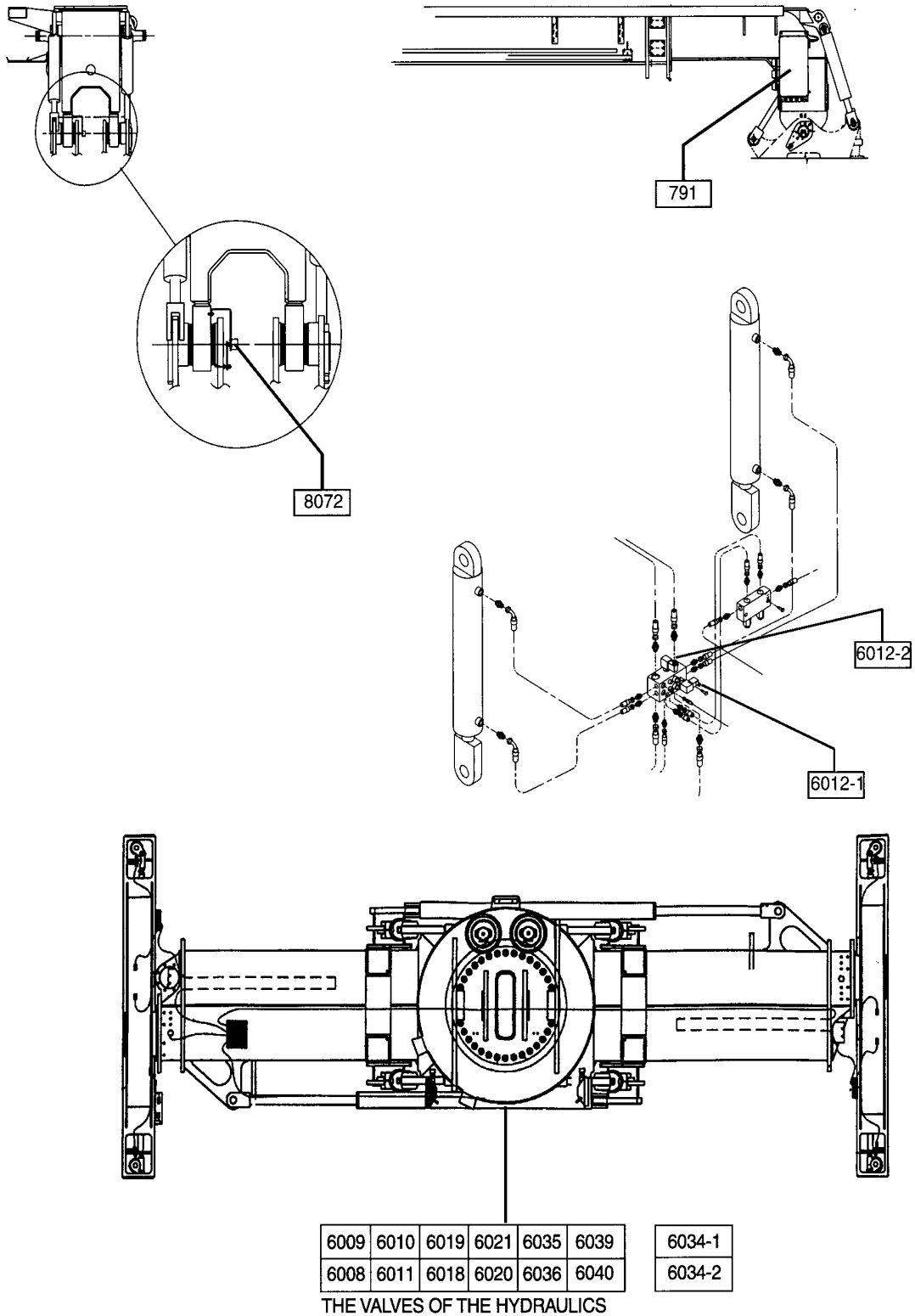
MALFUNCTION	TEST OR INSPECTION	CORRECTIVE ACTION
<p>Error Code 271 - Tophandler Leveling Left, Short Circuit Failure.</p>  <p>DIAG ATTACHMENT 14 (16) OSC, RI OSC, LE</p>	<ol style="list-style-type: none"> 1. Check wires and connectors at tophandler control valve and tophandler junction box for damage. 2. Disconnect connector 6036 from the tophandler leveling left solenoid. Check resistance of the solenoid between both pins and between each pin and ground (WP 0048 00-27). Resistance of the solenoid should be 18 to 26 Ohms. 3. Disconnect connector X189 from tophandler junction box and disconnect solenoid 6036. Check for short to ground at loose part of X189 at pin H (wire 189H) (WP 0048 00-27). 4. Disconnect ECU (791) connector 3. Inspect ECU and connector pins for damage. Check wire A189H (pin 13) for short to ground (WP 0048 00-27). 	<ol style="list-style-type: none"> a. Repair or replace connectors (WP 0113 00). b. Replace damaged wiring harness (WP 0221 00). <p style="text-align: center;">CAUTION</p> <p style="text-align: center;">Uncontrolled function may occur with this error code.</p> <ol style="list-style-type: none"> Replace open or shorted solenoid (WP 0171 00). Replace shorted/grounded X189 to solenoids wiring harness (WP 0221 00). a. Repair or replace shorted wires or connectors (WP 0113 00). b. Replace ECU (791) (WP 0077 00). <p style="text-align: center;">NOTE</p> <p style="text-align: center;">Multiple error codes associated with a common connector on ECU (791) may be the result of a short to ground in the harness for the common solenoid voltage. (See WP 0005 00 for troubleshooting multiple error codes.)</p>



350-1034



350-1342



END OF WORK PACKAGE

THIS WORK PACKAGE COVERS

Error Code 225 - Tophandler Sideshift Left, Open Circuit Failure

Error Code 228 - Tophandler Sideshift Right, Open Circuit Failure

Error Code 226 - Tophandler Sideshift Left, Short Circuit Failure

Error Code 229 - Tophandler Sideshift Right, Short Circuit Failure

INITIAL SETUP

References

TM 10-3930-675-10

ECS Attachment (A34652.0200) (WP 0048 00-23)

NOTE

- Refer to WP 0004 00 for additional troubleshooting guidance, information, and illustrations that locate critical components.
- Refer also to illustration at end of work package for component location.

Table 1. Error Code 225 - Tophandler Sideshift Left, Open Circuit Failure Troubleshooting Procedures.

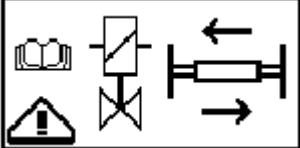
MALFUNCTION	TEST OR INSPECTION	CORRECTIVE ACTION												
<p>Error Code 225 - Tophandler Sideshift Left, Open Circuit Failure.</p>  <table border="1" data-bbox="272 1402 597 1539"> <tr> <td colspan="3">DIAG ATTACHMENT 7(16)</td> </tr> <tr> <td colspan="3">SIDE SH. OUTPUT/INPUT</td> </tr> <tr> <td>LEFT</td> <td>0.00mV</td> <td>0mA</td> </tr> <tr> <td>RIGHT</td> <td>0.00mV</td> <td>0mA</td> </tr> </table>	DIAG ATTACHMENT 7(16)			SIDE SH. OUTPUT/INPUT			LEFT	0.00mV	0mA	RIGHT	0.00mV	0mA	<ol style="list-style-type: none"> 1. Check wires and connectors at tophandler control valve and tophandler junction box for damage. 2. Enter DIAG ATTACHMENT 7(16) in the diagnostic menu. Activate the left sideshift function. 3. Disconnect connector 6020 from the tophandler left sideshift solenoid. Turn the ignition ON and check voltage (15 to 18V) between both pins of the connector. 	<ol style="list-style-type: none"> a. Repair or replace connectors (WP 0113 00). b. Replace damaged wiring harness (WP 0221 00). <p>If no INPUT mA values display, continue with troubleshooting procedure.</p> <ol style="list-style-type: none"> a. If no voltage (15 to 18V) is found, check continuity of wires 189A and 189B (WP 0048 00-27). b. If voltage (15 to 18V) is found, check resistance of 6020 solenoid. Resistance should be 18 to 26 Ohms. c. Replace open or faulty solenoid (WP 0170 00). d. Replace X189 to solenoids wiring harness (WP 0221 00).
DIAG ATTACHMENT 7(16)														
SIDE SH. OUTPUT/INPUT														
LEFT	0.00mV	0mA												
RIGHT	0.00mV	0mA												

Table 1. Error Code 225 - Tophandler Sideshift Left, Open Circuit Failure Troubleshooting Procedures - Continued.

MALFUNCTION	TEST OR INSPECTION	CORRECTIVE ACTION
<p>Error Code 225 - Tophandler Sideshift Left, Open Circuit Failure - Continued.</p>	<p>4. Disconnect connector X189 from the tophandler junction box. Turn the ignition ON. Check voltage (15 to 18V) at the mounted part of the connector between pins A and B.</p> <p>5. Disconnect ECU (791) connector 2. Inspect ECU and connector pins for damage.</p>	<p>a. If no voltage (15-18V) is found, check continuity of wires A3018A, A3018B, and A189B (WP 0048 00-26 and WP 0048 00-28).</p> <p>b. Repair or replace damaged wires or connectors (WP 0113 00).</p> <p>a. Repair or replace damaged connector (WP 0113 00).</p> <p>b. Replace ECU (791) (WP 0077 00).</p> <p style="text-align: center;">NOTE</p> <p>Multiple error codes associated with a common connector on ECU (791) may be the result of a short to ground in the harness for the common solenoid voltage. (See WP 0005 00 for troubleshooting multiple error codes.)</p>

Table 2. Error Code 226 - Tophandler Sideshift Left, Short Circuit Failure Troubleshooting Procedures.

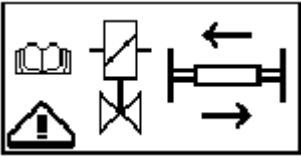
MALFUNCTION	TEST OR INSPECTION	CORRECTIVE ACTION												
<p>Error Code 226 - Tophandler Sideshift Left, Short Circuit Failure.</p>  <table border="1" data-bbox="272 709 602 846"> <tr> <td colspan="3">DIAG ATTACHMENT 7(16)</td> </tr> <tr> <td colspan="3">SIDE SH. OUTPUT/INPUT</td> </tr> <tr> <td>LEFT</td> <td>0.00mV</td> <td>0mA</td> </tr> <tr> <td>RIGHT</td> <td>0.00mV</td> <td>0mA</td> </tr> </table>	DIAG ATTACHMENT 7(16)			SIDE SH. OUTPUT/INPUT			LEFT	0.00mV	0mA	RIGHT	0.00mV	0mA	<ol style="list-style-type: none"> 1. Check wires and connectors at tophandler control valve and tophandler junction box for damage. <p style="text-align: center;">CAUTION</p> <p style="text-align: center;">Uncontrolled function may occur with this error code.</p> <ol style="list-style-type: none"> 2. Disconnect connector 6020 from the tophandler left sideshift solenoid. Check resistance of the solenoid between both pins and between each pin and ground (WP 0048 00-27). Resistance of the solenoid should be 18 to 26 Ohms. 3. Disconnect connector X189 from tophandler junction box and disconnect solenoid 6020. Check for short to ground at loose part of X189 at pin B (wire 189B) (WP 0048 00-26). 4. Disconnect ECU (791) connector 2. Inspect ECU and connector pins for damage. Check wire A189B (pin 3) for short to ground (WP 0048 00-27). <p style="text-align: center;">NOTE</p> <p style="text-align: center;">Multiple error codes associated with a common connector on ECU (791) may be the result of a short to ground in the harness for the common solenoid voltage. (See WP 0005 00 for troubleshooting multiple error codes.)</p>	<ol style="list-style-type: none"> a. Repair or replace connectors (WP 0113 00). b. Replace damaged wiring harness (WP 0221 00). <p>Replace open or shorted solenoid (WP 0171 00).</p> <p>Replace shorted/grounded X189 to solenoids wiring harness (WP 0221 00).</p> <ol style="list-style-type: none"> a. Repair or replace shorted wires or connectors (WP 0113 00). b. Replace ECU (791) (WP 0077 00).
DIAG ATTACHMENT 7(16)														
SIDE SH. OUTPUT/INPUT														
LEFT	0.00mV	0mA												
RIGHT	0.00mV	0mA												

Table 3. Error Code 228 - Tophandler Sideshift Right, Open Circuit Failure Troubleshooting Procedures.

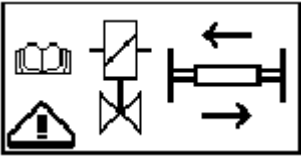
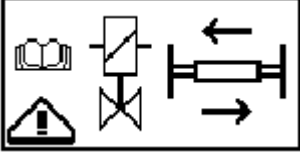
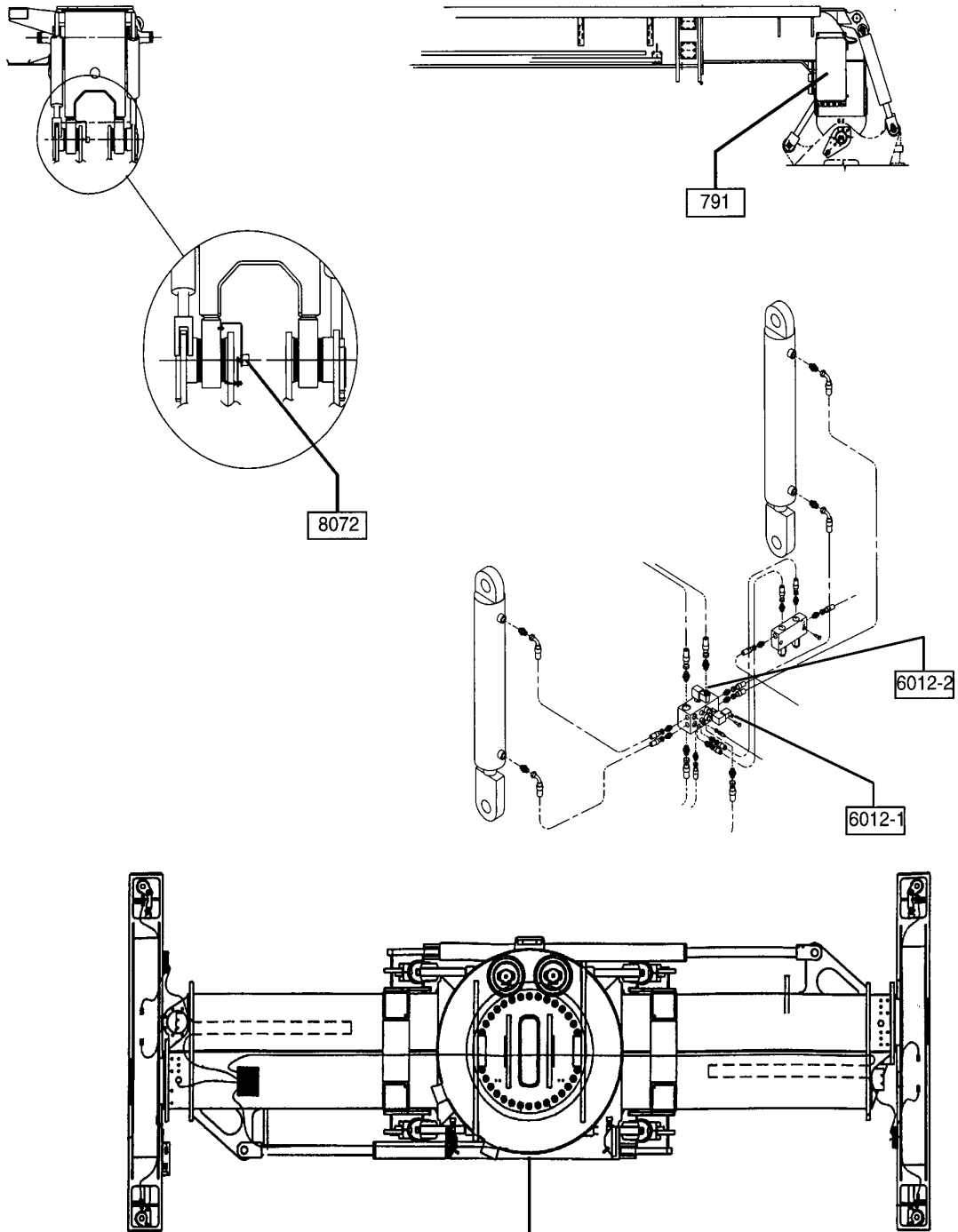
MALFUNCTION	TEST OR INSPECTION	CORRECTIVE ACTION												
<p>Error Code 228 - Tophandler Sideshift Right, Open Circuit Failure.</p>  <table border="1" data-bbox="276 646 609 783"> <tr> <td colspan="3">DIAG ATTACHMENT 7(16)</td> </tr> <tr> <td>SIDE</td> <td>SH. OUTPUT/INPUT</td> <td></td> </tr> <tr> <td>LEFT</td> <td>0.00mV</td> <td>0mA</td> </tr> <tr> <td>RIGHT</td> <td>0.00mV</td> <td>0mA</td> </tr> </table>	DIAG ATTACHMENT 7(16)			SIDE	SH. OUTPUT/INPUT		LEFT	0.00mV	0mA	RIGHT	0.00mV	0mA	<ol style="list-style-type: none"> 1. Check wires and connectors at tophandler control valve and tophandler junction box for damage. 2. Enter DIAG ATTACHMENT 7(16) in the diagnostic menu. Activate the right sideshift function. 3. Disconnect connector 6021 from the tophandler right sideshift solenoid. Turn the ignition ON and check voltage (15 to 18V) between both pins of the connector. 4. Disconnect connector X189 from the tophandler junction box. Turn the ignition ON. Check voltage (15 to 18V) at the mounted part of the connector between pins C and D. 5. Disconnect ECU (791) connector 2. Inspect ECU and connector pins for damage. <p style="text-align: center;">NOTE</p> <p>Multiple error codes associated with a common connector on ECU (791) may be the result of a short to ground in the harness for the common solenoid voltage. (See WP 0005 00 for troubleshooting multiple error codes.)</p>	<ol style="list-style-type: none"> a. Repair or replace connectors (WP 0113 00). b. Replace damaged wiring harness (WP 0221 00). <p>If no INPUT mA values display; continue with troubleshooting procedure.</p> <ol style="list-style-type: none"> a. If no voltage (15 to 18V) is found, check continuity of wires 189C and 189D (WP 0048 00-26). b. If voltage (15 to 18V) is found, check resistance of 6021 solenoid. Resistance should be 18 to 26 Ohms. c. Replace open or faulty solenoid (WP 0171 00). d. Replace X189 to solenoids wiring harness (WP 0221 00). <ol style="list-style-type: none"> a. If no voltage (15 to 18V) is found, check continuity of wires A3018A, A3018B, A3018C and A189D (WP 0048 00-26 and WP 0048 00-28). b. Repair or replace damaged wires or connectors (WP 0113 00). <ol style="list-style-type: none"> a. Repair or replace damaged connector (WP 0113 00). b. Replace ECU (791) (WP 0080 00).
DIAG ATTACHMENT 7(16)														
SIDE	SH. OUTPUT/INPUT													
LEFT	0.00mV	0mA												
RIGHT	0.00mV	0mA												

Table 4. Error Code 229 - Tophandler Sideshift Right, Short Circuit Failure Troubleshooting Procedures.

MALFUNCTION	TEST OR INSPECTION	CORRECTIVE ACTION
<p>Error Code 229 - Tophandler Sideshift Right, Short Circuit Failure.</p>  <div data-bbox="269 646 599 783" style="border: 1px solid black; padding: 5px;"> <p>DIAG ATTACHMENT 7(16) SIDE SH. OUTPUT/INPUT LEFT 0.00mV 0mA RIGHT 0.00mV 0mA</p> </div>	<ol style="list-style-type: none"> 1. Check wires and connectors at tophandler control valve and tophandler junction box for damage. <p style="text-align: center;">CAUTION</p> <p style="text-align: center;">Uncontrolled function may occur with this error code.</p> <ol style="list-style-type: none"> 2. Disconnect connector 6021 from the tophandler right sideshift solenoid. Check resistance of the solenoid between both pins and between each pin and ground (WP 0048 00-26). Resistance of the solenoid should be 18 to 26 Ohms. 3. Disconnect connector X189 from tophandler junction box and disconnect solenoid 6021. Check for short to ground at loose part of X189 at pin D (wire 189D) (WP 0048 00-26). 4. Disconnect ECU (791) connector 2. Inspect ECU and connector pins for damage. Check wire A189D (pin 11) for short to ground (WP 0048 00-26). <p style="text-align: center;">NOTE</p> <p style="text-align: center;">Multiple error codes associated with a common connector on ECU (791) may be the result of a short to ground in the harness for the common solenoid voltage. (See WP 0005 00 for troubleshooting multiple error codes.)</p>	<ol style="list-style-type: none"> a. Repair or replace connectors (WP 0113 00). b. Replace damaged wiring harness (WP 0221 00). <p>Replace open or shorted solenoid (WP 0171 00).</p> <p>Replace shorted/grounded X189 to solenoids wiring harness (WP 0221 00).</p> <ol style="list-style-type: none"> a. Repair or replace shorted wires or connectors (WP 0113 00). b. Replace ECU (791) (WP 0077 00).



6009	6010	6019	6021	6035	6039	6034-1
6008	6011	6018	6020	6036	6040	6034-2

THE VALVES OF THE HYDRAULICS

END OF WORK PACKAGE

THIS WORK PACKAGE COVERS

Error Code 231 - Tophandler Spreader Opening, Open Circuit Failure

Error Code 234 - Tophandler Spreader Closing, Open Circuit Failure

Error Code 232 - Tophandler Spreader Opening, Short Circuit Failure

Error Code 235 - Tophandler Spreader Closing, Short Circuit Failure

INITIAL SETUP

References

TM 10-3930-675-10

ECS Attachment (A34652.0200) (WP 0048 00-23)

NOTE

- Refer to WP 0004 00 for additional troubleshooting guidance, information, and illustrations that locate critical components.
- Refer also to illustration at end of work package for component location.

Table 1. Error Code 231 - Tophandler Spreader Opening, Open Circuit Failure Troubleshooting Procedures.

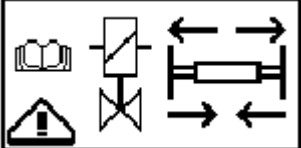
MALFUNCTION	TEST OR INSPECTION	CORRECTIVE ACTION																
<p>Error Code 231 - Tophandler Spreader Opening, Open Circuit Failure.</p>  <table border="1" data-bbox="289 1423 587 1558"> <tr> <td colspan="4">DIAG ATTACHMENT 8 (16)</td> </tr> <tr> <td>OUTPUT</td> <td>INPUT</td> <td></td> <td></td> </tr> <tr> <td>20' -> 40'</td> <td>0mA</td> <td>0mA</td> <td></td> </tr> <tr> <td>40' -> 20'</td> <td>0mA</td> <td>0mA</td> <td></td> </tr> </table>	DIAG ATTACHMENT 8 (16)				OUTPUT	INPUT			20' -> 40'	0mA	0mA		40' -> 20'	0mA	0mA		<ol style="list-style-type: none"> 1. Check wires and connectors at tophandler control valve and tophandler junction box for damage. 2. Enter DIAG ATTACHMENT 8(16) in the diagnostic menu. Activate the spreader opening function. 3. Disconnect connector 6018 from the tophandler spreading out solenoid. Turn the ignition ON and check voltage (15 to 18V) between both pins of the connector. 	<ol style="list-style-type: none"> a. Repair or replace connectors (WP 0113 00). b. Replace damaged wiring harness (WP 0221 00). <p>If no INPUT mA values display, continue with troubleshooting procedure.</p> <ol style="list-style-type: none"> a. If no voltage (15 to 18V) is found, check continuity of wires 188J and 188K (WP 0048 00-26). b. If voltage (15 to 18V) is found, check resistance of 6018 solenoid. Resistance should be 18 to 26 Ohms. c. Replace open of faulty solenoid (WP 0171 00). d. Replace X188 to solenoids wiring harness to solenoids wiring harness (WP 0221 00).
DIAG ATTACHMENT 8 (16)																		
OUTPUT	INPUT																	
20' -> 40'	0mA	0mA																
40' -> 20'	0mA	0mA																

Table 1. Error Code 231 - Tophandler Spreader Opening, Open Circuit Failure Troubleshooting Procedures - Continued.

MALFUNCTION	TEST OR INSPECTION	CORRECTIVE ACTION
<p>Error Code 231 - Tophandler Spreader Opening, Open Circuit Failure - Continued.</p>	<p>4. Disconnect connector X188 from the tophandler junction box. Turn the ignition ON. Check voltage (15 to 18V) at the mounted part of the connector between pins J and K.</p> <p>5. Disconnect ECU (791) connector 2. Inspect ECU and connector pins for damage.</p>	<p>a. If no voltage (15 to 18V) is found, check continuity of wires A3018A through H, and A188K (WP 0048 00-26 and WP 0048 00-28).</p> <p>b. Repair or replace damaged wires or connectors (WP 0113 00).</p> <p>a. Repair or replace damaged connector (WP 0113 00).</p> <p>b. Replace ECU (791) (WP 0077 00).</p> <p style="text-align: center;">NOTE</p> <p>Multiple error codes associated with a common connector on ECU (791) may be the result of a short to ground in the harness for the common solenoid voltage. (See WP 0005 00 for troubleshooting multiple error codes.)</p>

Table 2. Error Code 232 - Tophandler Spreader Opening, Short Circuit Failure Troubleshooting Procedures.

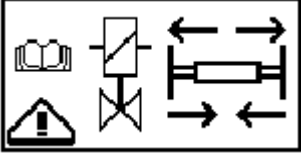
MALFUNCTION	TEST OR INSPECTION	CORRECTIVE ACTION												
<p>Error Code 232 - Tophandler Spreader Opening, Short Circuit Failure.</p>  <table border="1" data-bbox="289 678 602 814"> <tr> <td>DIAG ATTACHMENT</td> <td colspan="2">8 (16)</td> </tr> <tr> <td></td> <td>OUTPUT</td> <td>INPUT</td> </tr> <tr> <td>20' -> 40'</td> <td>0mA</td> <td>0mA</td> </tr> <tr> <td>40' -> 20'</td> <td>0mA</td> <td>0mA</td> </tr> </table>	DIAG ATTACHMENT	8 (16)			OUTPUT	INPUT	20' -> 40'	0mA	0mA	40' -> 20'	0mA	0mA	<ol style="list-style-type: none"> 1. Check wires and connectors at tophandler control valve and tophandler junction box for damage. 2. Disconnect connector 6018 from the tophandler spreading out solenoid. Check resistance of the solenoid between both pins and between each pin and ground (WP 0048 00-26). Resistance of the solenoid should be 18 to 26 Ohms. 3. Disconnect connector X188 from tophandler junction box and disconnect solenoid 6018. Check for short to ground at loose part of X188 at pin K (wire 188K) (WP 0048 00-27). 4. Disconnect ECU (791) connector 2. Inspect ECU and connector pins for damage. Check wire A188K (pin 4) for short to ground (WP 0048 00-26). 	<ol style="list-style-type: none"> a. Repair or replace connectors (WP 0113 00). b. Replace damaged wiring harness (WP 0221 00). <p style="text-align: center;">CAUTION</p> <p style="text-align: center;">Uncontrolled function may occur with this error code.</p> <ol style="list-style-type: none"> Replace open or shorted solenoid (WP 0171 00). Replace shorted/grounded X188 to solenoids wiring harness (WP 0221 00). a. Repair or replace shorted wires or connectors (WP 0113 00). b. Replace ECU (791) (WP 0077 00). <p style="text-align: center;">NOTE</p> <p style="text-align: center;">Multiple error codes associated with a common connector on ECU (791) may be the result of a short to ground in the harness for the common solenoid voltage. (See WP 0005 00 for troubleshooting multiple error codes.)</p>
DIAG ATTACHMENT	8 (16)													
	OUTPUT	INPUT												
20' -> 40'	0mA	0mA												
40' -> 20'	0mA	0mA												

Table 3. Error Code 234 - Tophandler Spreader Closing, Open Circuit Failure Troubleshooting Procedures.

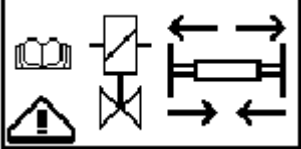
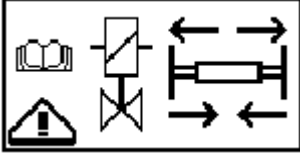
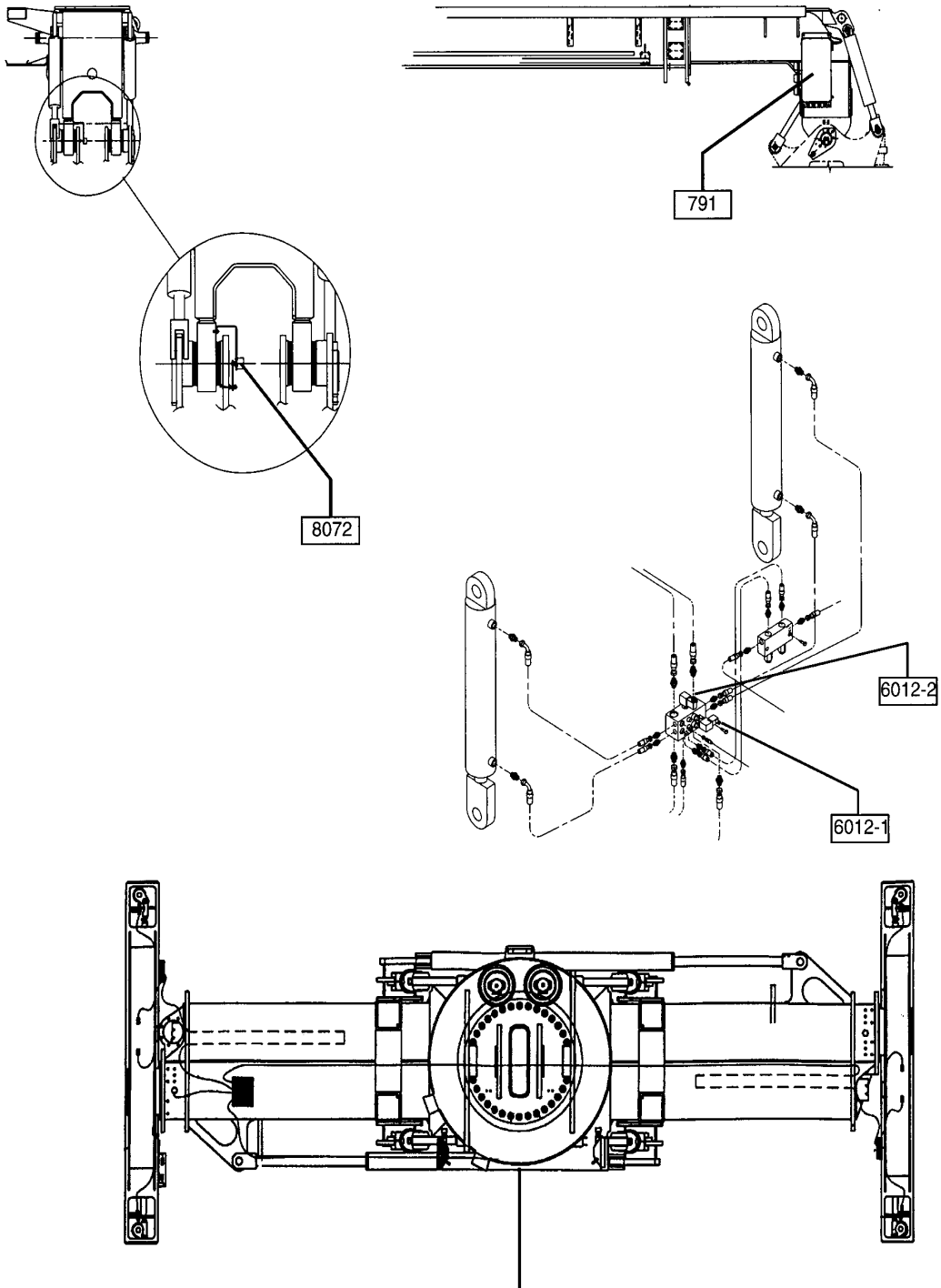
MALFUNCTION	TEST OR INSPECTION	CORRECTIVE ACTION
<p>Error Code 234 - Tophandler Spreader Closing, Open Circuit Failure.</p>  <pre data-bbox="289 705 599 842"> DIAG ATTACHMENT 8(16) OUTPUT INPUT 20' ->40' 0mA 0mA 40' ->20' 0mA 0mA </pre>	<ol style="list-style-type: none"> 1. Check wires and connectors at tophandler control valve and tophandler junction box for damage. 2. Enter DIAG ATTACHMENT 8(16) in the diagnostic menu. Activate the spreader closing function. 3. Disconnect connector 6019 from the tophandler spreading in solenoid. Turn the ignition ON and check voltage (15-18V) between both pins of the connector. 4. Disconnect connector X188 for the tophandler junction box. Turn the ignition ON. Check voltage (15-18V) at the mounted part of the connector between pins L and M. 5. Disconnect ECU (791) connector 2. Inspect ECU and connector pins for damage. <p style="text-align: center;">NOTE</p> <p>Multiple error codes associated with a common connector on ECU (791) may be the result of a short to ground in the harness for the common solenoid voltage. (See WP 0005 00 for troubleshooting multiple error codes.)</p>	<ol style="list-style-type: none"> a. Repair or replace connectors (WP 0113 00). b. Replace damaged wiring harness (WP 0221 00). <p>If no INPUT mA values display, continue with troubleshooting procedure.</p> <ol style="list-style-type: none"> a. If no voltage (15-18V) is found, check continuity of wires 188L and 188M (WP 0048 00-26). b. If voltage (15-18V) is found, check resistance of 6019 solenoid. Resistance should be 18 to 26 Ohms. c. Replace open or faulty solenoid (WP 0169 00). d. Replace X188 to solenoids wiring harness (WP 0221 00). <ol style="list-style-type: none"> a. If no voltage (15-18V) is found, check continuity of wires A3018A through H and A188M (WP 0048 00-26 and WP 0048 00-28). b. Repair or replace damaged wires or connectors (WP 0113 00). <ol style="list-style-type: none"> a. Repair or replace damaged connector (WP 0111 00). b. Replace ECU (791) (WP 0077 00).

Table 4. Error Code 235 - Tophandler Spreader Closing, Short Circuit Failure Troubleshooting Procedures.

MALFUNCTION	TEST OR INSPECTION	CORRECTIVE ACTION																
<p>Error Code 235 - Tophandler Spreader Closing, Short Circuit Failure.</p>  <table border="1" data-bbox="284 667 581 802"> <tr> <td>DIAG</td> <td>TOP</td> <td>LIFT</td> <td>8(16)</td> </tr> <tr> <td></td> <td></td> <td>OUTPUT</td> <td>INPUT</td> </tr> <tr> <td>20'</td> <td>-></td> <td>40'</td> <td>0mA 0mA</td> </tr> <tr> <td>40'</td> <td>-></td> <td>20'</td> <td>0mA 0mA</td> </tr> </table>	DIAG	TOP	LIFT	8(16)			OUTPUT	INPUT	20'	->	40'	0mA 0mA	40'	->	20'	0mA 0mA	<ol style="list-style-type: none"> 1. Check wires and connectors at tophandler control valve and tophandler junction box for damage. 2. Disconnect connector 6019 from the tophandler spreading in solenoid. Check resistance of the solenoid between both pins and between each pin and ground (WP 0048 00-26). Resistance of the solenoid should be 18 to 26 Ohms. 3. Disconnect connector X188 from tophandler junction box and disconnect solenoid 6019. Check for short to ground at loose part of X188 at pin M (wire 188M) (WP 0048 00-26). 4. Disconnect ECU (791) connector 2. Inspect ECU and connector pins for damage. Check wire A188M (pin 12) for short to ground (WP 0048 00-26). 	<ol style="list-style-type: none"> a. Repair or replace connectors (WP 0113 00). b. Replace damaged wiring harness (WP 0221 00). <p style="text-align: center;">CAUTION</p> <p style="text-align: center;">Uncontrolled function may occur with this error code.</p> <ol style="list-style-type: none"> a. Repair or replace shorted wires or connectors (WP 0113 00). b. Replace ECU (791) (WP 0077 00). <p style="text-align: center;">NOTE</p> <p style="text-align: center;">Multiple error codes associated with a common connector on ECU (791) may be the result of a short to ground in the harness for the common solenoid voltage. (See WP 0005 00 for troubleshooting multiple error codes.)</p>
DIAG	TOP	LIFT	8(16)															
		OUTPUT	INPUT															
20'	->	40'	0mA 0mA															
40'	->	20'	0mA 0mA															



6009	6010	6019	6021	6035	6039	6034-1
6008	6011	6018	6020	6036	6040	6034-2

THE VALVES OF THE HYDRAULICS

END OF WORK PACKAGE

THIS WORK PACKAGE COVERS

Error Code 212 - Tophandler Left Twistlocks Indication Failure

Error Code 243 - Tophandler Twistlock Locking Circuit Failure

Error Code 213 - Tophandler Right Twistlocks Indication Failure

Error Code 246 - Tophandler Twistlock Unlocking Circuit Failure

Error Code 214 - Tophandler Forklift Sensor Indication Failure

INITIAL SETUP

References

TM 10-3930-675-10

Current Supply (A34738.0200) (WP 0048 00-31)

ECS Attachment (A34652.0200) (WP 0048 00-23)

NOTE

- Refer to WP 0004 00 for additional troubleshooting guidance, information, and illustrations that locate critical components.
- Refer also to illustrations at end of work package for component location.

Table 1. Error Code 212 - Tophandler Left Twistlocks Indication Failure Troubleshooting Procedures.

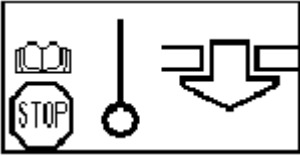
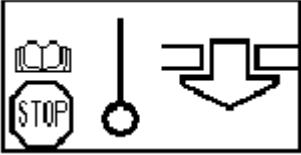
MALFUNCTION	TEST OR INSPECTION	CORRECTIVE ACTION
<p>Error Code 212 - Tophandler Left Twistlocks Indication Failure.</p>  <pre data-bbox="289 1549 586 1682"> DIAG ATTACHMENT 4(16) TWIST LOCK LE UNL. 1 RI UNL. 1 LE LOCK 0 RI LOCK 0 </pre>	<ol style="list-style-type: none"> 1. Enter DIAG ATTACHMENT 4(16) in the diagnostic menu. Check the left twistlocks LOCKED and UNLOCKED status. (Logical Error indicates both twistlock signals are ON at the same time.) 2. Inspect the left twistlock proximity switches for damage, obstructions, and adjustments. 	<ol style="list-style-type: none"> a. Use the override switch to operate the twistlocks (TM 10-3930-675-10). Observe the status indication in the diagnostic menu screen. Observe the changing of the twistlock indicator lights. b. If both LOCKED and UNLOCKED are "1" at the same time, continue with step 2. <ol style="list-style-type: none"> a. Replace damaged proximity switch (WP 0075 00). b. Remove any obstructions and clean proximity switch ends. c. Check and adjust proximity switch gap (5mm) (WP 0075 00).

Table 1. Error Code 212 - Tophandler Left Twistlocks Indication Failure Troubleshooting Procedures - Continued.

MALFUNCTION	TEST OR INSPECTION	CORRECTIVE ACTION
<p>Error Code 212 - Tophandler Left Twistlocks Indication Failure - Continued.</p>	<p>3. Remove cover to X183. Inspect wire connections at pins 5 and 6 (WP 0048 00-24). Compare wire connections with the diagram.</p> <p>4. Make sure the twistlocks are in the UNLOCKED position. Check voltage (24V) between X183 pins 4 and 5 and between 4 and 6 (WP 0048 00-24).</p> <p>5. Make sure the twistlocks are in the LOCKED position. Check voltage (24V) between X183 pins 4 and 5 and between 4 and 6 (WP 0048 00-24).</p> <p>6. Remove the cover to X182. Inspect wire connections (WP 0048 00-24). Compare wire connections with the diagram.</p> <p>7. Check X182 to X181 cable for damage, continuity, or shorts between wires (WP 0113 00).</p> <p>8. Disconnect ECU (791) connector 1. Inspect ECU and connector pins for damage. Check continuity and for shorts between wires of the wiring from connector 1 (WP 0048 00-24 and WP 0048 00-25).</p>	<p>Correct any wiring error or damage (WP 0048 00-24).</p> <p>If voltage (24V) is found between pins 4 and 6, replace left twistlock LOCKED proximity switch (WP 0075 00).</p> <p>If voltage (24V) is found between pins 4 and 5, replace left twistlock "locked" proximity switch (WP 0075 00).</p> <p>a. Correct any wiring error or damage (WP 0048 00-24). b. Check cable X182 to X183 for damage, continuity or shorts between wires (WP 0113 00). c. Replace X182 to X183 cable (WP 0221 00).</p> <p>If X182 and X181 cable is damaged, has no continuity, or is shorted between wires, replace X182 to X181 cable (WP 0221 00).</p> <p>a. Repair or replace damaged wires or connectors (WP 0113 00). b. Replace ECU (791) (WP 0077 00).</p>

Table 2. Error Code 213 - Tophandler Right Twistlocks Indication Failure Troubleshooting Procedures.

MALFUNCTION	TEST OR INSPECTION	CORRECTIVE ACTION
<p>Error Code 213 - Tophandler Right Twistlocks Indication Failure.</p>  <div style="border: 1px solid black; padding: 5px; margin-top: 10px;"> <p>DIAG ATTACHMENT 4(16) TWIST LOCK</p> <p>LE UNL. 1 RI UNL. 1 LE LOCK 0 RI LOCK 0</p> </div>	<ol style="list-style-type: none"> 1. Enter DIAG ATTACHMENT 4(16) in the diagnostic menu. Check the right twistlocks LOCKED and UNLOCKED status. (Logical Error indicates both twistlock signals are “on” at the same time.) 2. Inspect the left twistlock proximity switches for damage, obstructions, and adjustments. 3. Remove cover to X184. Inspect wire connections at pins 5 and 6 (WP 0048 00-24). Compare wire connections with the diagram. 4. Make sure the twistlocks are in the UNLOCKED position. Check voltage (24V) between X184 pins 4 and 5 and between 4 and 6 (WP 0048 00-24). 5. Make sure the twistlocks are in the LOCKED position. Check voltage (24V) between X184 pins 4 and 5 and between 4 and 6 (WP 0048 00-24). 6. Remove the cover to X182. Inspect wire connections (WP 0048 00-24). Compare wire connections with the diagram. 	<ol style="list-style-type: none"> a. Use the override switch to operate the twistlocks (TM 10-3930-675-10). Observe the status indication in the diagnostic menu screen. Observe the changing of the twistlock indicator lights. b. If both LOCKED and UNLOCKED are “1” at the same time, continue with step 2. a. Replace damaged proximity switch (WP 0075 00). b. Remove any obstructions and clean proximity switch ends. c. Check and adjust proximity switch gap (5mm) (WP 0075 00). Correct any wiring error or damage (WP 0048 00-24). If voltage (24V) is found between pins 4 and 6, replace left twistlock LOCKED proximity switch (WP 0075 00). If voltage (24V) is found between pins 4 and 5, replace left twistlock LOCKED proximity switch (WP 0075 00). a. Correct any wiring error or damage (WP 0048 00-24). b. Check cable X182 to X184 for damage, continuity, or shorts between wires (WP 0113 00). c. Replace X182 to X184 cable (WP 0221 00).

**Table 3. Error Code 213 - Tophandler Right Twistlocks
Indication Failure Troubleshooting Procedures - Continued.**

MALFUNCTION	TEST OR INSPECTION	CORRECTIVE ACTION
<p>Error Code 213 - Tophandler Right Twistlocks Indication Failure - Continued.</p>	<p>7. Check X182 to X181 cable for damage, continuity or shorts between wires (WP 0113 00).</p> <p>8. Disconnect ECU (791) connector 1. Inspect ECU and connector pins for damage. Check continuity and for shorts between wires of the wiring from connector X181 to ECU (791) connector 1 (WP 0048 00-24 and WP 0048 00-25).</p>	<p>If X182 and X181 cable is damaged, has no continuity, or is shorted between wires, replace X182 to X181 cable (WP 0221 00).</p> <p>a. Repair or replace damaged wires or connectors (WP 0113 00).</p> <p>b. Replace ECU (791) (WP 0077 00).</p>

Table 4. Error Code 214 - Tophandler Forklift Sensor Indication Failure Troubleshooting Procedures.

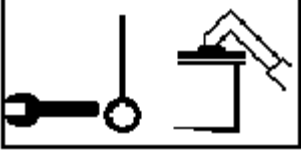
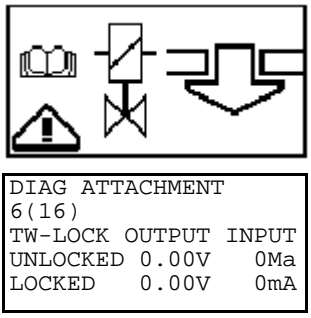
MALFUNCTION	TEST OR INSPECTION	CORRECTIVE ACTION										
<p>Error Code 214 - Tophandler Forklift Sensor Indication Failure.</p>  <table border="1" data-bbox="289 680 599 842"> <tr> <td colspan="2">DIAG ATTACHMENT 5(16)</td> </tr> <tr> <td>Rotation</td> <td>4/-25</td> </tr> <tr> <td>Damping</td> <td>20/40</td> </tr> <tr> <td>Attachment</td> <td>SIG 1</td> </tr> <tr> <td>Attachment</td> <td>SIG 2</td> </tr> </table>	DIAG ATTACHMENT 5(16)		Rotation	4/-25	Damping	20/40	Attachment	SIG 1	Attachment	SIG 2	<ol style="list-style-type: none"> 1. Enter DIAG ATTACHMENT 5(16) in the diagnostic menu. Check the attachment sig. 1 & 2 status. (Logical Error indicates one attachment sig. is not ON when both signals should be ON at the same time.) 2. Inspect the forklift sensor proximity switches for damage, obstructions, and adjustment (WP 0075 00). 3. Remove the cover to X183. Inspect wire connections at pins 3, 4, 7, and 8 (WP 0048 00-25). Compare wire connections with the diagram. 4. Check voltage (24V) between X183 pins 4 and 7 (WP 0048 00-25). 5. Check voltage (24V) between X183 pins 4 and 8 (WP 0048 00-25). 6. Remove the cover to X182. Inspect wire connections (WP 0048 00-24). Compare wire connections with the diagram. 7. Check X182 to X181 cable for damage, continuity, or shorts between wires (WP 0113 00). 	<ol style="list-style-type: none"> a. Check the actuating plunger by pushing up on the bottom of the shaft. b. Clean and lubricate stuck actuating plunger. c. If one attachment sig. is "0", push the actuating plunger several times to observe any indication changes. a. Replace damaged proximity switch (WP 0075 00). b. Remove any obstructions and clean proximity switch ends. c. Check and adjust proximity switch gap (5 mm) (WP 0075 00). Correct any wiring error or damage (WP 0048 00-24). If no voltage (24V) is found between pins 4 and 7, replace proximity switch 7206-1 (WP 0075 00). If no voltage (24V) is found between pins 4 and 8, replace proximity switch 7206-2 (WP 0075 00). a. Correct any wiring error or damage (WP 0048 00-24). b. Check cable X182 to X183 for damage, continuity, or shorts between wires (WP 0113 00). c. Replace X182 to X183 cable (WP 0221 00). If X182 to X181 cable is damaged, has no continuity, or is shorted between wires, replace X182 to X181 cable (WP 0221 00).
DIAG ATTACHMENT 5(16)												
Rotation	4/-25											
Damping	20/40											
Attachment	SIG 1											
Attachment	SIG 2											

Table 5. Error Code 214 - Tophandler Forklift Sensor Indication Failure Troubleshooting Procedures - Continued.

MALFUNCTION	TEST OR INSPECTION	CORRECTIVE ACTION
<p>Error Code 214 - Tophandler Forklift Sensor Indication Failure - Continued.</p>	<p>8. Disconnect ECU (791) connector 1. Inspect ECU and connector pins for damage. Check continuity and for shorts between wiring from connector X181 to ECU (791) connector 1 (WP 0048 00-24 and WP 0048 00-25).</p>	<p>a. Repair or replace damaged wires or connectors (WP 0113 00). b. Replace ECU (791) (WP 0077 00).</p>

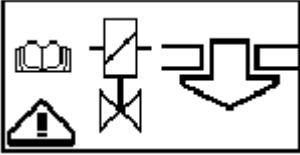
Table 6. Error Code 243 - Tophandler Twistlock Locking Circuit Failure Troubleshooting Procedures.

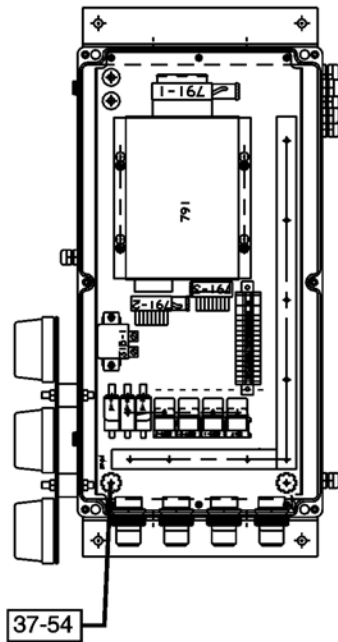
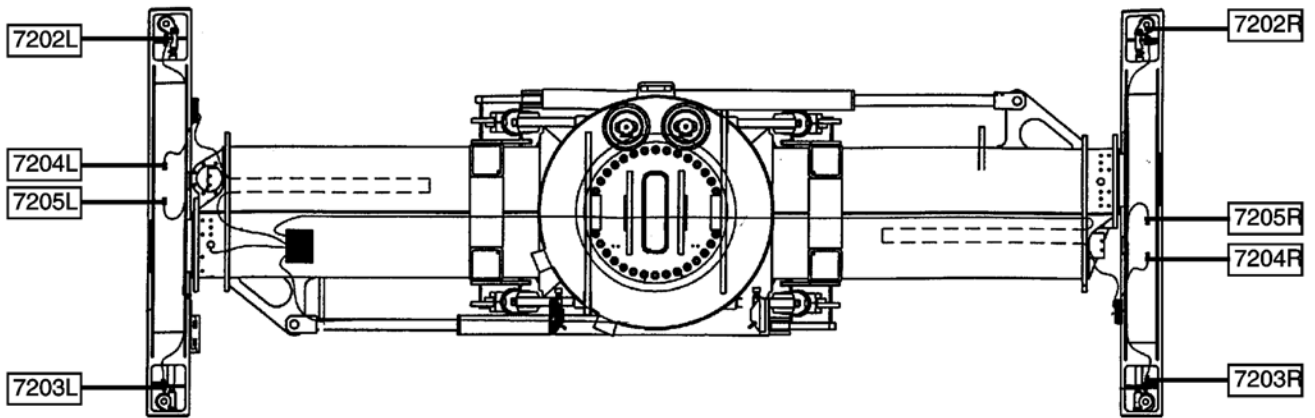
MALFUNCTION	TEST OR INSPECTION	CORRECTIVE ACTION
<p>Error Code 243 - Tophandler Twistlock Locking Circuit Failure.</p>  <p>DIAG ATTACHMENT 6(16) TW-LOCK OUTPUT INPUT UNLOCKED 0.00V 0Ma LOCKED 0.00V 0mA</p>	<p>1. Check wires and connectors at tophandler junction box for damage.</p> <p>2. Enter DIAG ATTACHMENT 6(16) in the diagnostic menu. Activate the twistlock function (override twistlocks.)</p> <p>3. Disconnect connector 6040 from the tophandler twistlock locking solenoid. Turn the ignition ON and check voltage (15 to 18V) between both pins of the connector.</p>	<p>a. Repair or replace connectors (WP 0113 00). b. Replace damaged wiring harness (WP 0221 00).</p> <p>If no INPUT mA values display, continue with troubleshooting procedure.</p> <p>a. If no voltage (15 to 18V) is found, check continuity of wires 189L and 189M (WP 0048 00-26). b. If voltage (15 to 18V) is found, check resistance of 6040 solenoid. Resistance should be 18 to 26 Ohms. c. Replace open or faulty solenoid (WP 0171 00). d. Replace X189 to solenoids wiring harness (WP 0221 00).</p>

**Table 4. Error Code 243 - Tophandler Twistlock Locking
Circuit Failure Troubleshooting Procedures - Continued.**

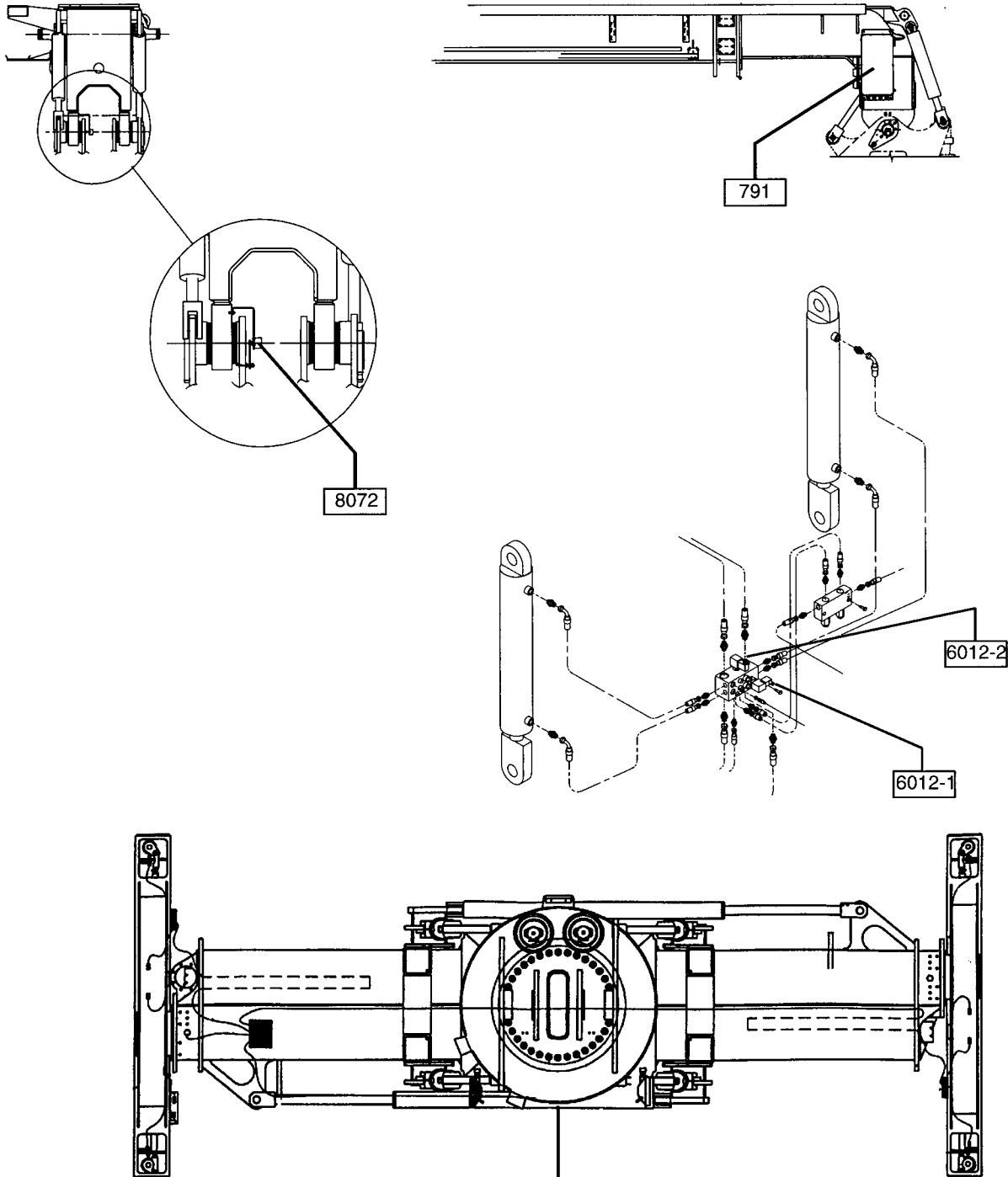
MALFUNCTION	TEST OR INSPECTION	CORRECTIVE ACTION
<p>Error Code 243 - Tophandler Twistlock Locking Circuit Failure - Continued.</p>	<p>4. Disconnect connector X189 from the tophandler junction box. Turn the ignition ON. Check voltage (15 to 18V) at the mounted part of the connector between pins L and M.</p> <p>5. Disconnect ECU (791) connector 2. Inspect ECU and connector pins for damage.</p>	<p>a. If no voltage (15 to 18V) is found, check continuity of wires A3018A through A3018F and A189M (WP 0048 00-26 and WP 0048 00-28).</p> <p>b. Repair or replace damaged wires or connectors (WP 0113 00).</p> <p>a. Repair or replace damaged connector (WP 0113 00).</p> <p>b. Replace ECU (791) (WP 0077 00).</p> <p style="text-align: center;">NOTE</p> <p>Multiple error codes associated with a common connector on ECU (791) may be the result of a short to ground in the harness for the common solenoid voltage. (See WP 0005 00 for troubleshooting multiple error codes.)</p>

Table 7. Error Code 246 - Tophandler Twistlock Unlocking Circuit Failure Troubleshooting Procedures.

MALFUNCTION	TEST OR INSPECTION	CORRECTIVE ACTION								
<p>Error Code 246 - Tophandler Twistlock Unlocking Circuit Failure.</p>  <table border="1" data-bbox="289 684 599 821"> <tr> <td>DIAG ATTACHMENT 6(16)</td> <td></td> </tr> <tr> <td>TW-LOCK OUTPUT</td> <td>INPUT</td> </tr> <tr> <td>UNLOCKED 0.00V</td> <td>0Ma</td> </tr> <tr> <td>LOCKED 0.00V</td> <td>0mA</td> </tr> </table>	DIAG ATTACHMENT 6(16)		TW-LOCK OUTPUT	INPUT	UNLOCKED 0.00V	0Ma	LOCKED 0.00V	0mA	<ol style="list-style-type: none"> 1. Check wires and connectors at tophandler control valve and tophandler junction box for damage. 2. Enter DIAG ATTACHMENT 6(16) in the diagnostic menu. Activate the twistlock function (override twistlocks). 3. Disconnect connector 6039 from the tophandler twistlock unlocking solenoid. Turn the ignition ON and check voltage (15 to 18V) between both pins of the connector. 4. Disconnect connector X189 from the tophandler junction box. Turn the ignition ON. Check voltage (15 to 18V) at the mounted part of the connector between pins J and K. 5. Disconnect ECU (791) connector 2. Inspect ECU and connector pins for damage. 	<ol style="list-style-type: none"> a. Repair or replace connectors (WP 0113 00). b. Replace damaged wiring harness (WP 0221 00). <p>If no INPUT mA values display, continue with troubleshooting procedure.</p> <ol style="list-style-type: none"> a. If no voltage (15 to 18V) is found, check continuity of wires 189J and 189K (WP 0048 00-26). b. If voltage (15 to 18V) is found, check resistance of 6039 solenoid. Resistance should be 18 to 26 Ohms. c. Replace open or faulty solenoid (WP 0171 00). d. Replace X189 to solenoids wiring harness (WP 0221 00). <ol style="list-style-type: none"> a. If no voltage (15 to 18V) is found, check continuity of wires A3018A through A3018E, and A189K (WP 0048 00-26 and WP 0048 00-28). b. Repair or replace damaged wires or connectors (WP 0113 00). <ol style="list-style-type: none"> a. Repair or replace damaged connector (WP 0113 00). b. Replace ECU (791) (WP 0077 00). <p style="text-align: center;">NOTE</p> <p>Multiple error codes associated with a common connector on ECU (791) may be the result of a short to ground in the harness for the common solenoid voltage. (See WP 0005 00 for troubleshooting multiple error codes.)</p>
DIAG ATTACHMENT 6(16)										
TW-LOCK OUTPUT	INPUT									
UNLOCKED 0.00V	0Ma									
LOCKED 0.00V	0mA									



350-1038



6009	6010	6019	6021	6035	6039	6034-1
6008	6011	6018	6020	6036	6040	6034-2

THE VALVES OF THE HYDRAULICS

350-1037

END OF WORK PACKAGE

NOTE

Refer to legends and notes at end of Work Package for an explanation of common electrical and hydraulic symbols.

Electrical Schematics

Figure 1. ECS Display/CAN-BUS (A34647.0200) Page 1 of 3..... 0048 00-2

Figure 2. ECS Electrical Servo (A34648.0200) Page 1 of 5..... 0048 00-5

Figure 3. ECS Engine (A34649.0200) Page 1 of 2..... 0048 00-10

Figure 4. ECS Transmission (A34650.0200) Page 1 of 4..... 0048 00-12

Figure 5. ECS Steering (A34651.0200) Page 1 of 7..... 0048 00-16

Figure 6. ECS Attachment to Tophandler (A34652.0200) Page 1 of 6. 0048 00-23

Figure 7. Hydraulics (A34654.0200) Page 1 of 2..... 0048 00-29

Figure 8. Current Supply (A34738.0200) Page 1 of 4. 0048 00-31

Figure 9. Shifting (A34739.0200) Page 1 of 1..... 0048 00-35

Figure 10. Sender (A34740.0200) Page 1 of 2. 0048 00-36

Figure 11. Wipers (A34741.0200) Page 1 of 1..... 0048 00-38

Figure 12. AC and Fan (A34742.0200) Page 1 of 1..... 0048 00-39

Figure 13. Cab (A34743.0200) Page 1 of 1. 0048 00-40

Figure 14. Lights (A34744.0200) Page 1 of 5. 0048 00-41

Figure 15. Work Lights (A34745.0200) Page 1 of 1. 0048 00-46

Figure 16. Auxiliary Pump (A34746.0200) Page 1 of 1..... 0048 00-47

Figure 17. Auto Lubrication (A48665.0100) Page 1 of 1..... 0048 00-48

Figure 18. Information (A34749.0200) Page 1 of 2..... 0048 00-49

Hydraulic Diagrams, Symbols, and Diagram Notes

Figure 19. Steering System..... 0048 00-51

Figure 20. Brake System..... 0048 00-52

Figure 21. Main System. 0048 00-53

Figure 22. Tophandler System. 0048 00-54

Symbol Legends

Figure 23. Autolube System Tubing Layout..... 0048 00-55

Figure 24. Electrical Symbols..... 0048 00-56

Figure 25. Hydraulic Symbols. 0048 00-57

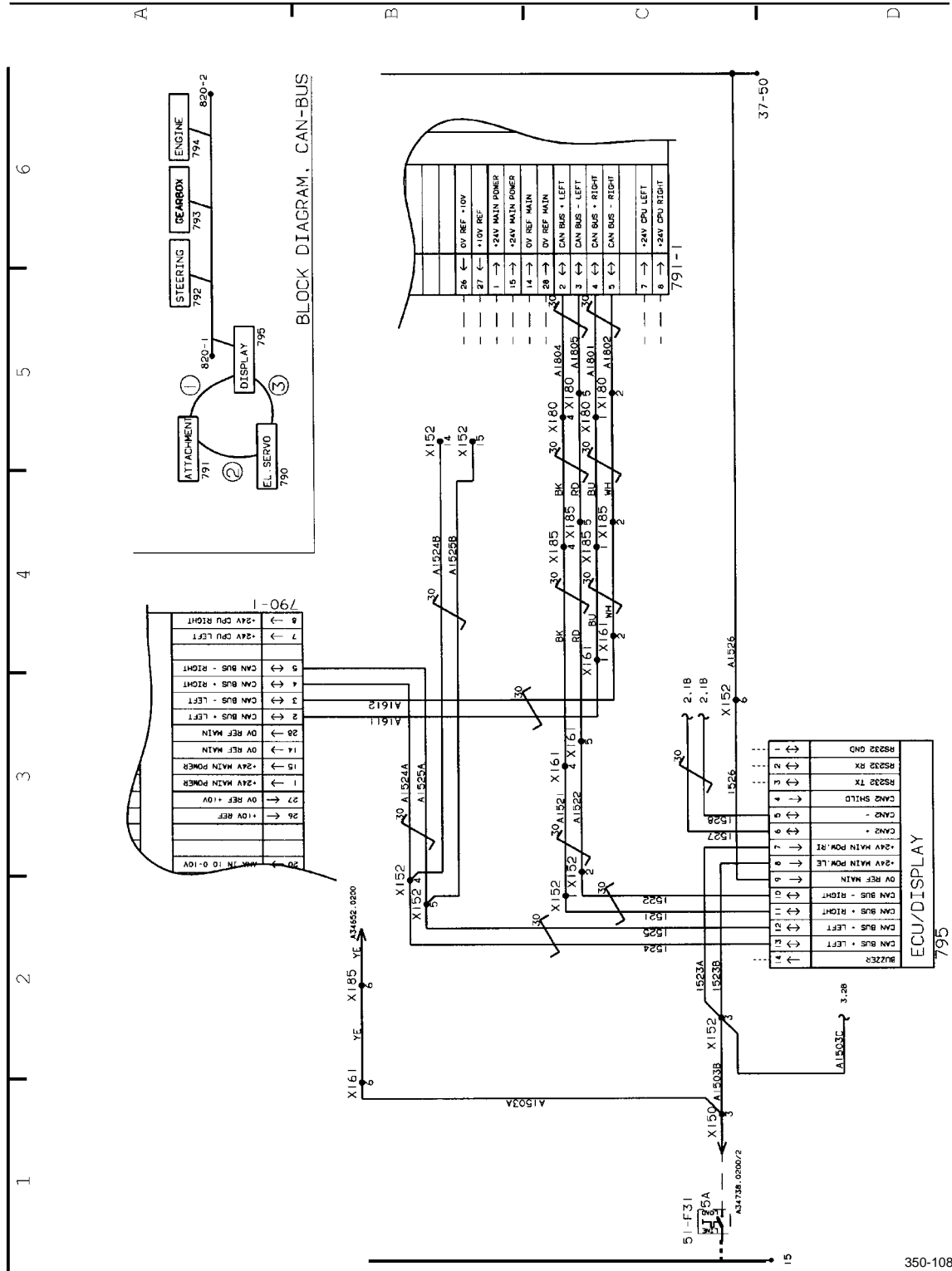


Figure 1. ECS Display/CAN-BUS (A34647.0200) Page 1 of 3.

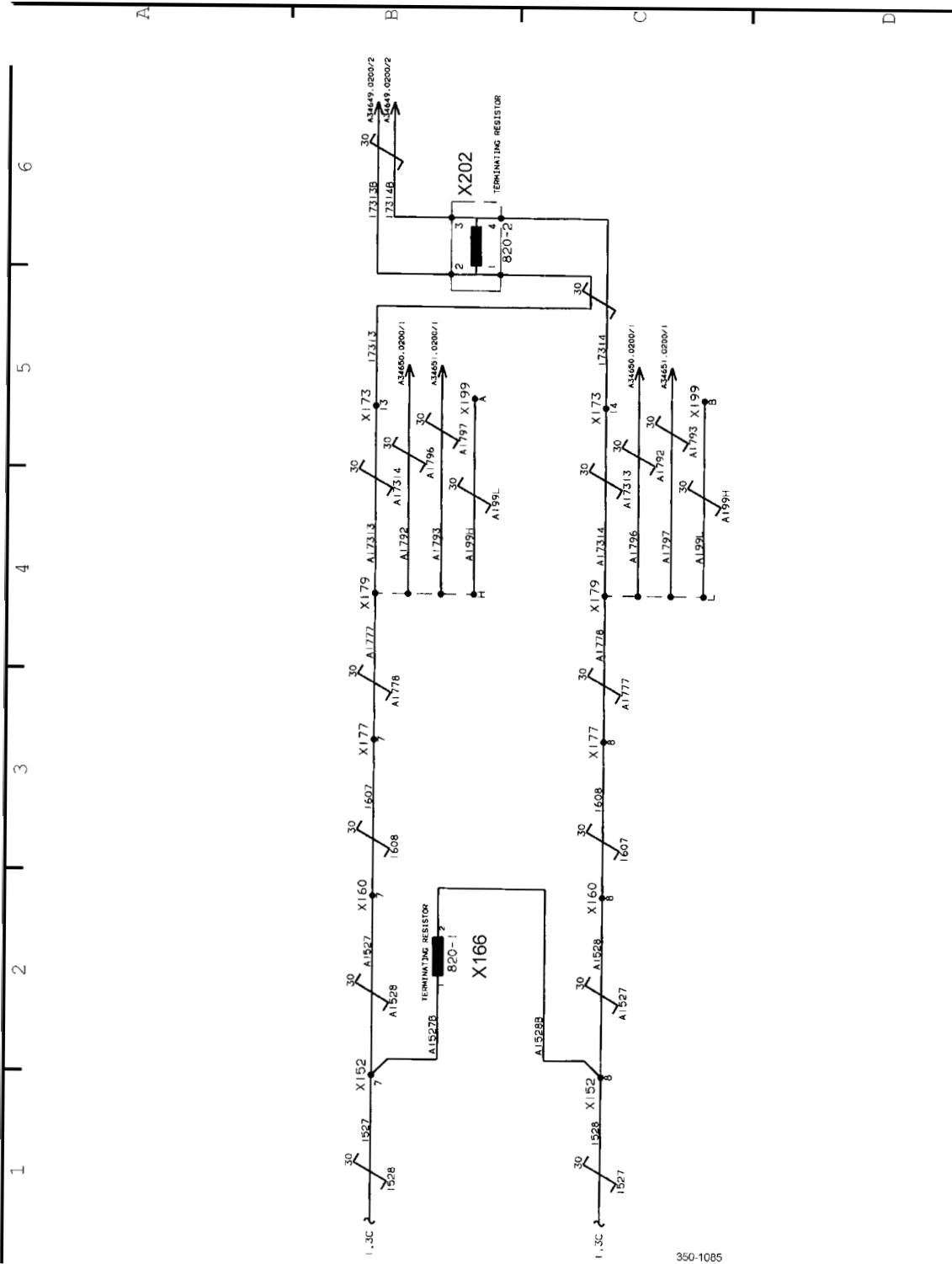


Figure 1. ECS Display/CAN-BUS (A34647.0200) Page 2 of 3.

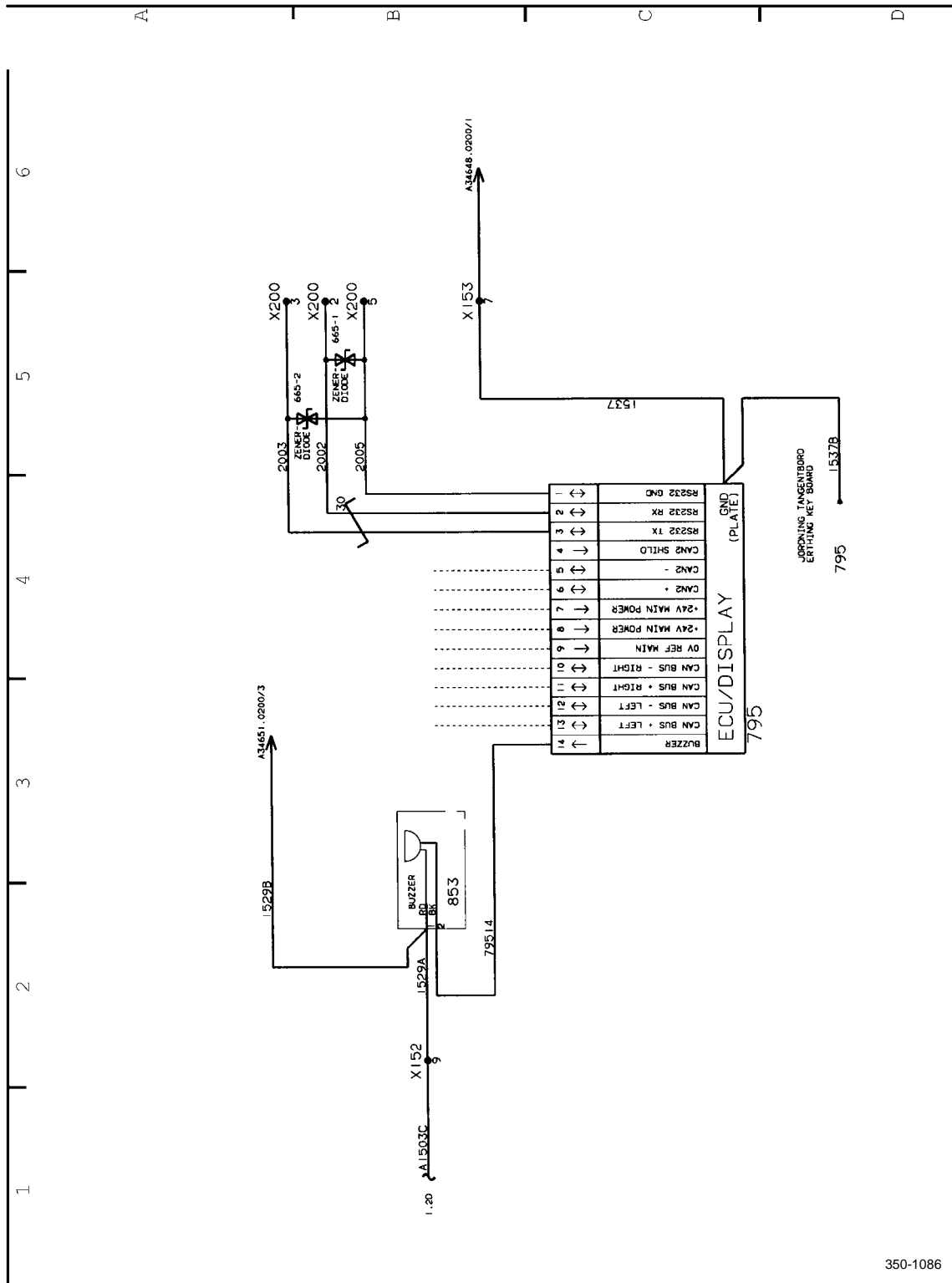


Figure 1. ECS Display/CAN-BUS (A34647.0200) Page 3 of 3.

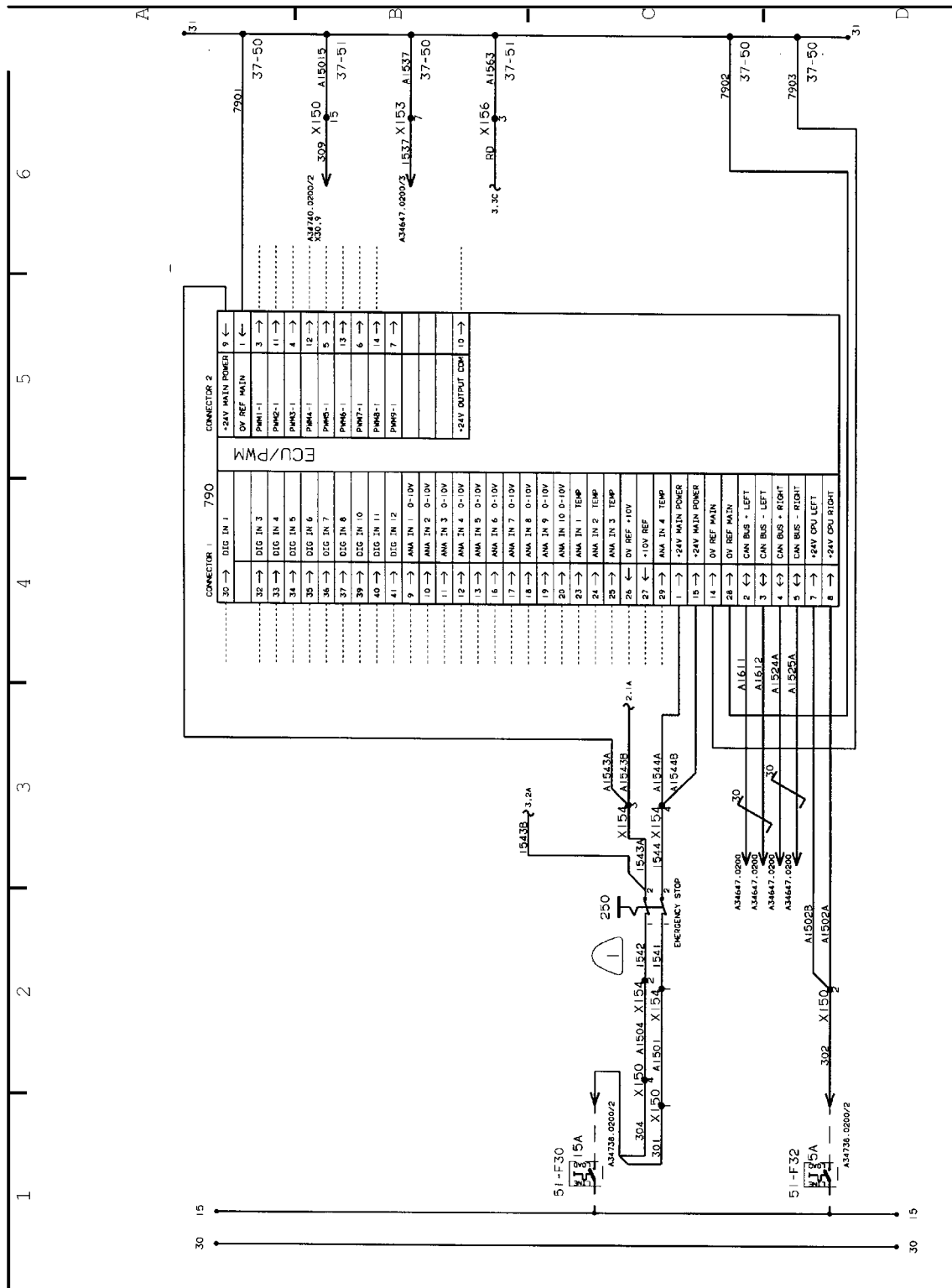


Figure 2. ECS Electrical Servo (A34648.0200) Page 1 of 5.

350-1067

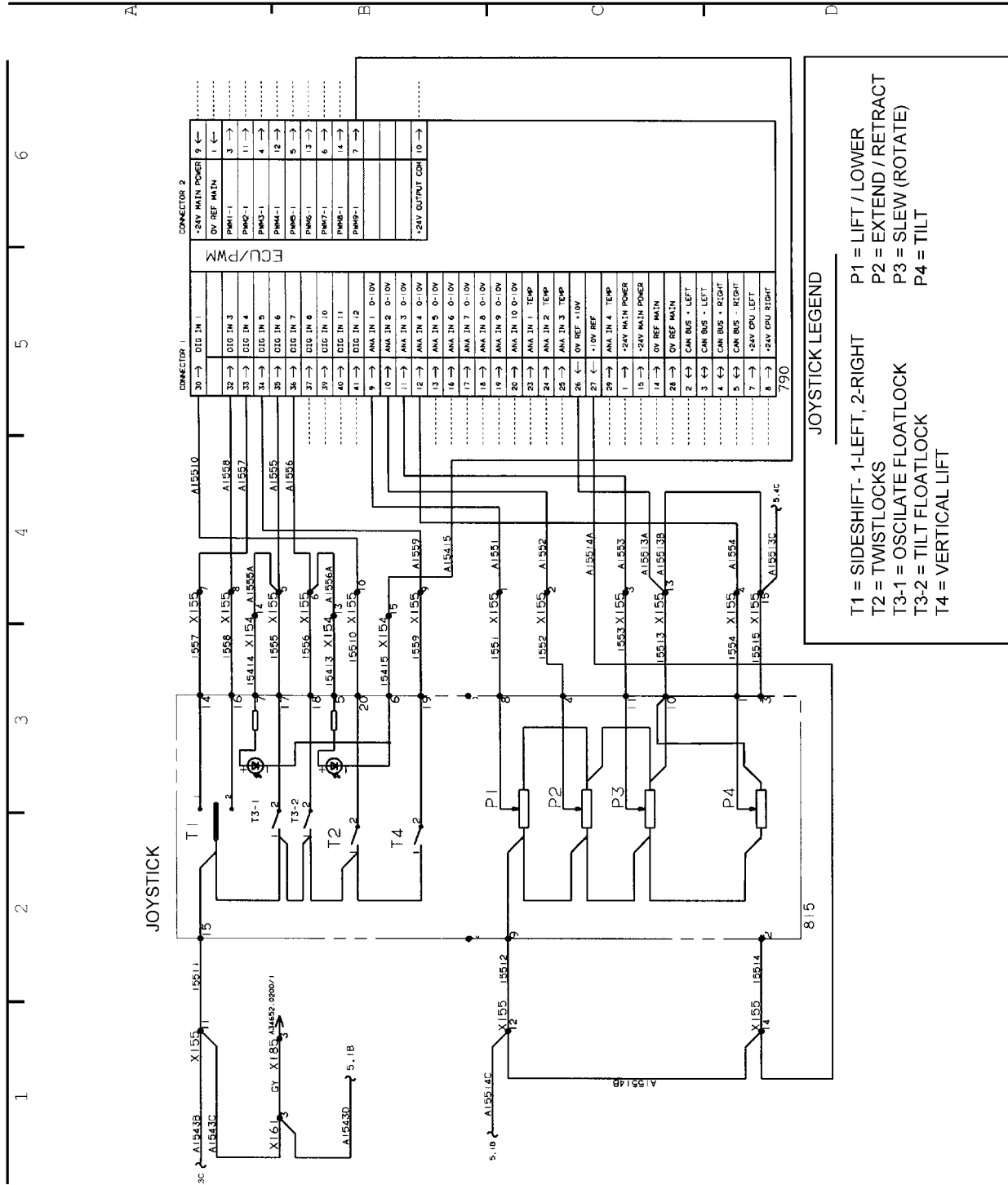


Figure 2. ECS Electrical Servo (A34648.0200) Page 2 of 5.

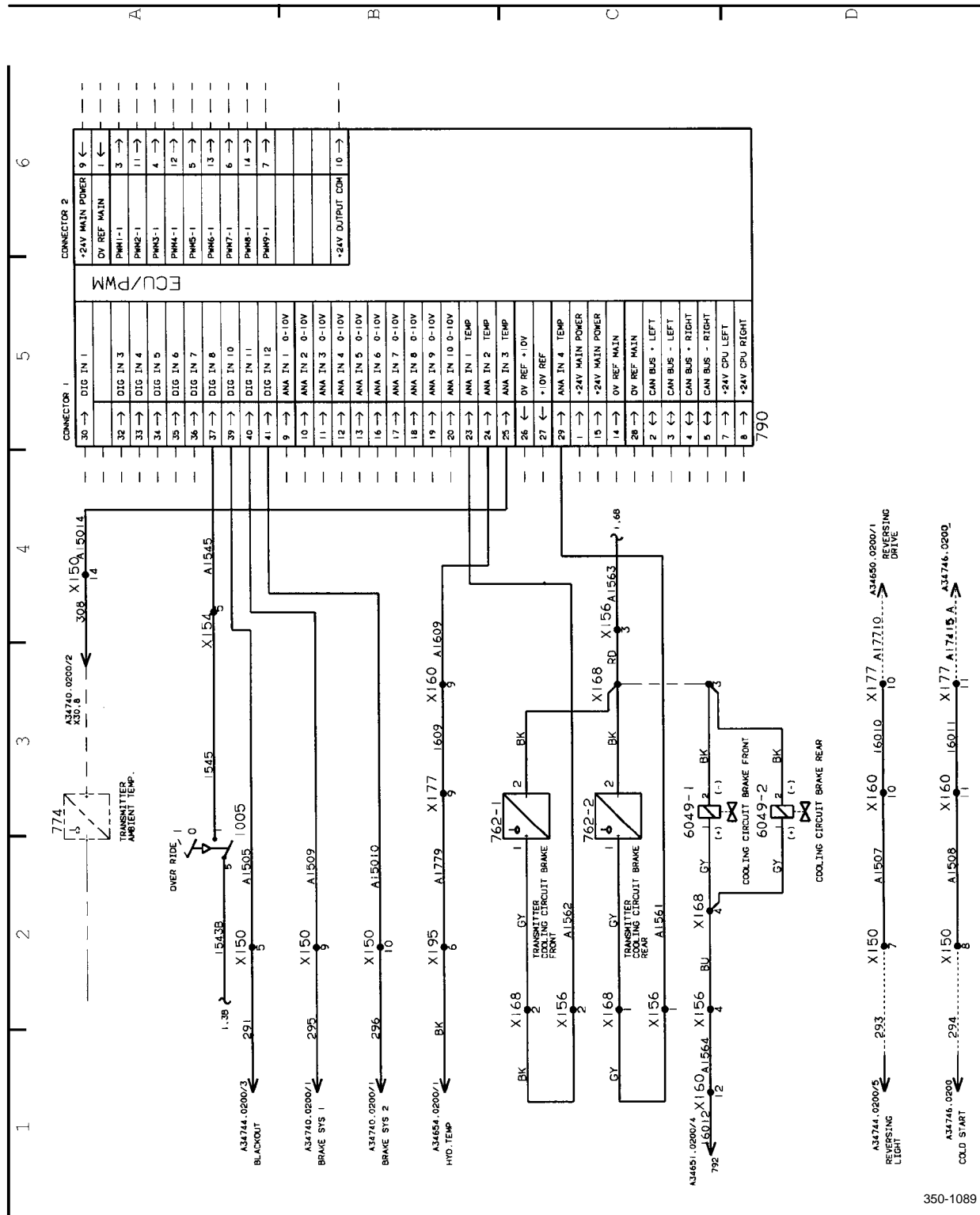
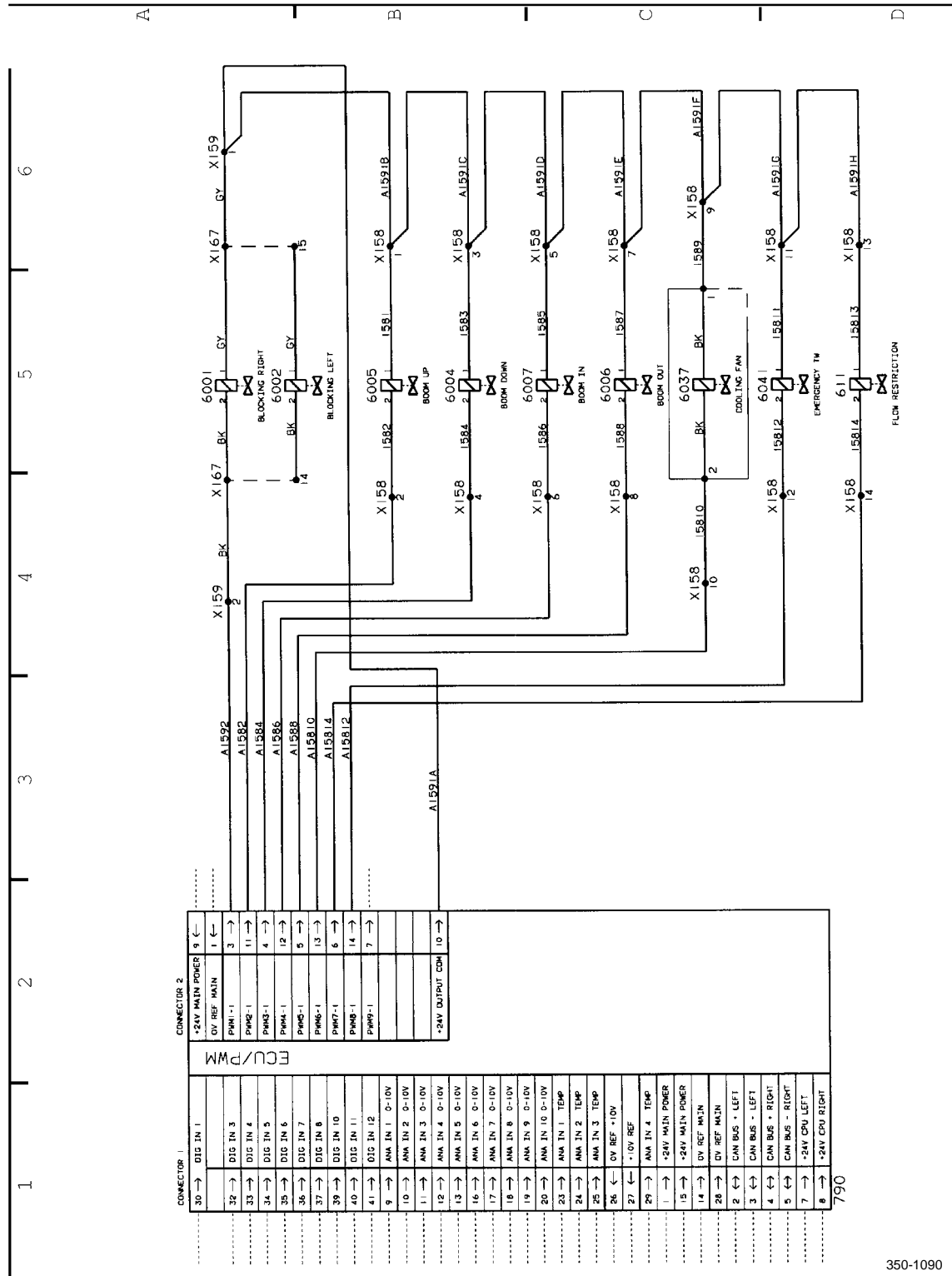


Figure 2. ECS Electrical Servo (A34648.0200) Page 3 of 5.



350-1090

Figure 2. ECS Electrical Servo (A34648.0200) Page 4 of 5.

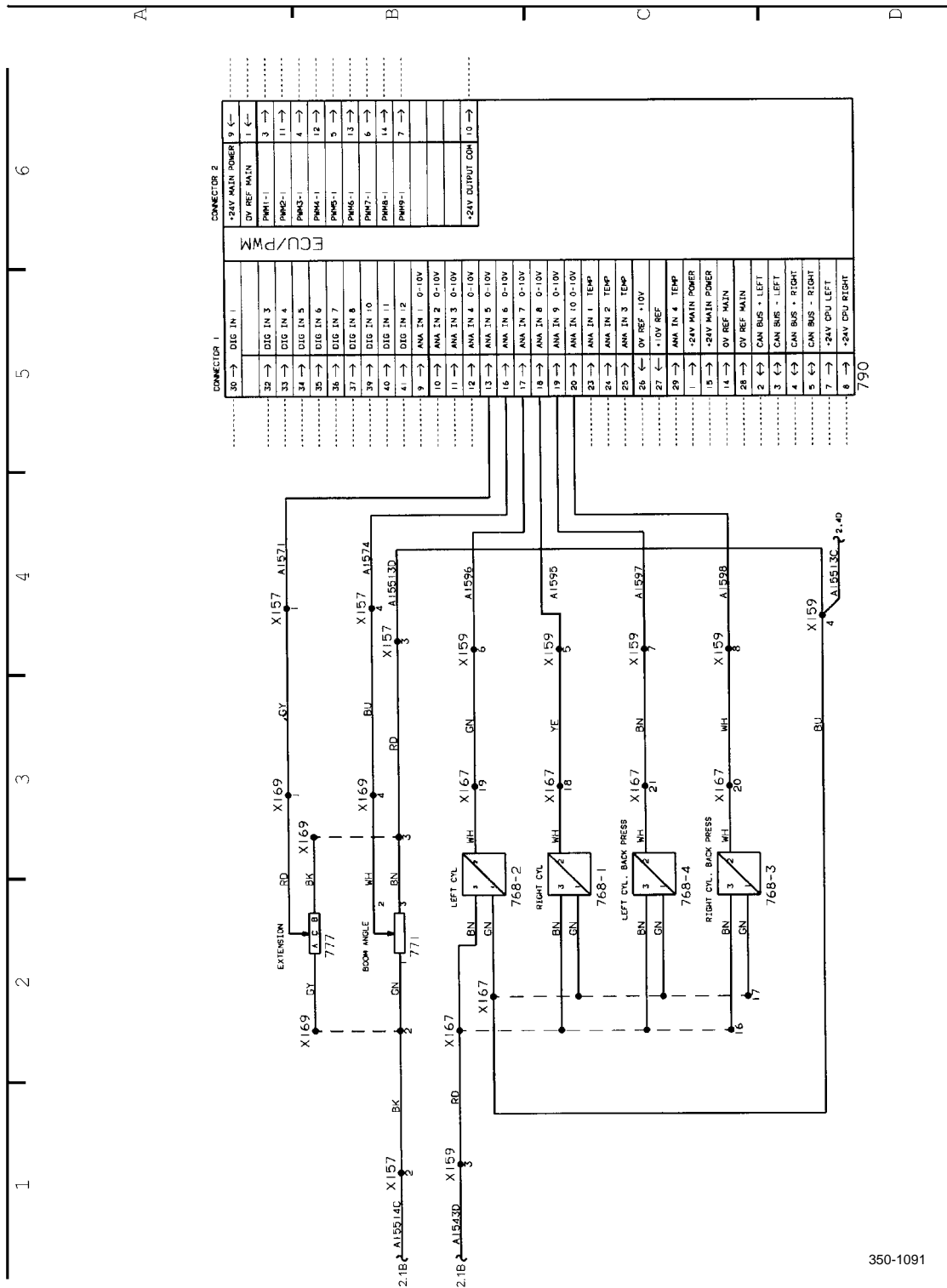


Figure 2. ECS Electrical Servo (A34648.0200) Page 5 of 5.

350-1091

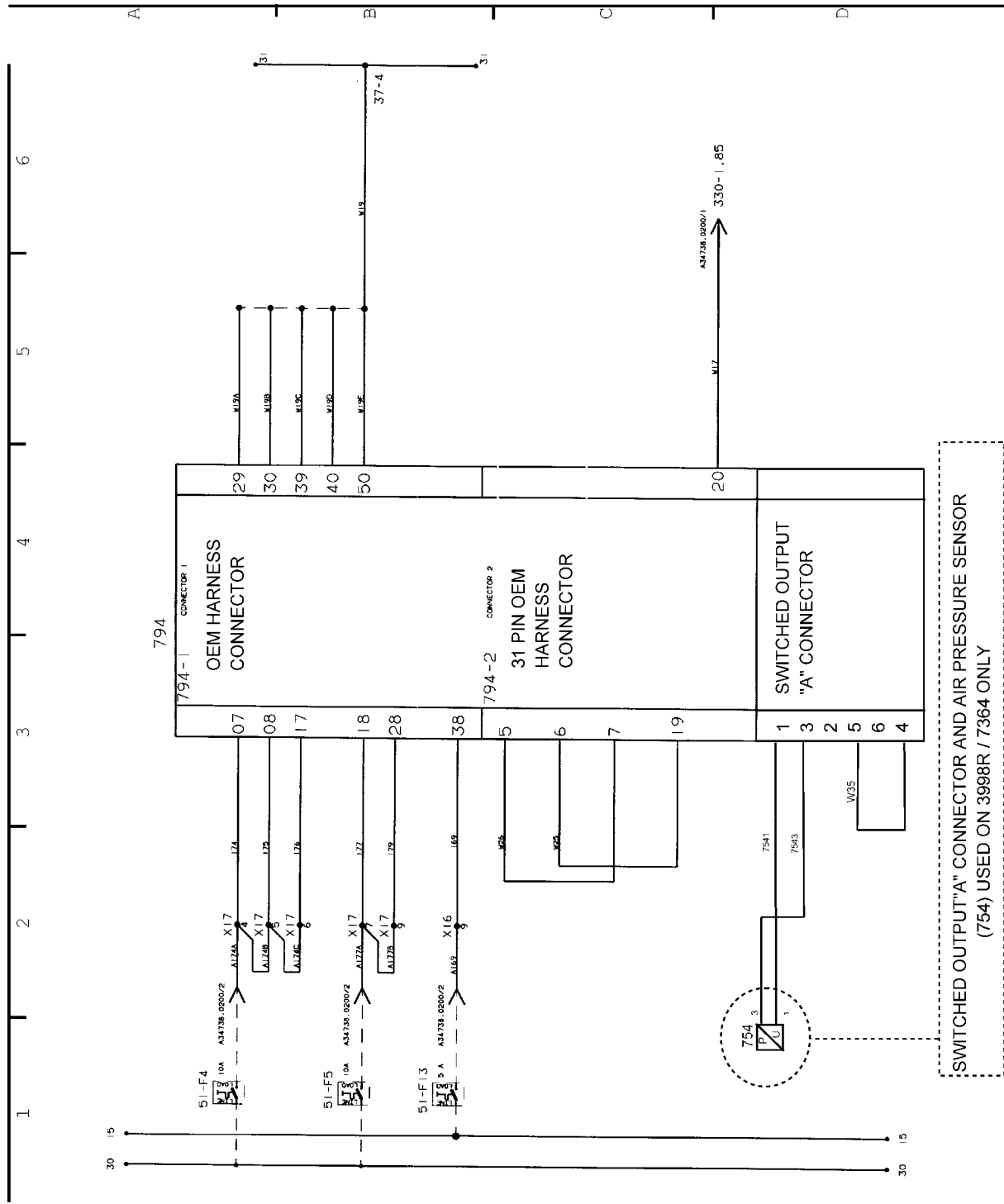


Figure 3. ECS Engine (A34649.0200) Page 1 of 2.

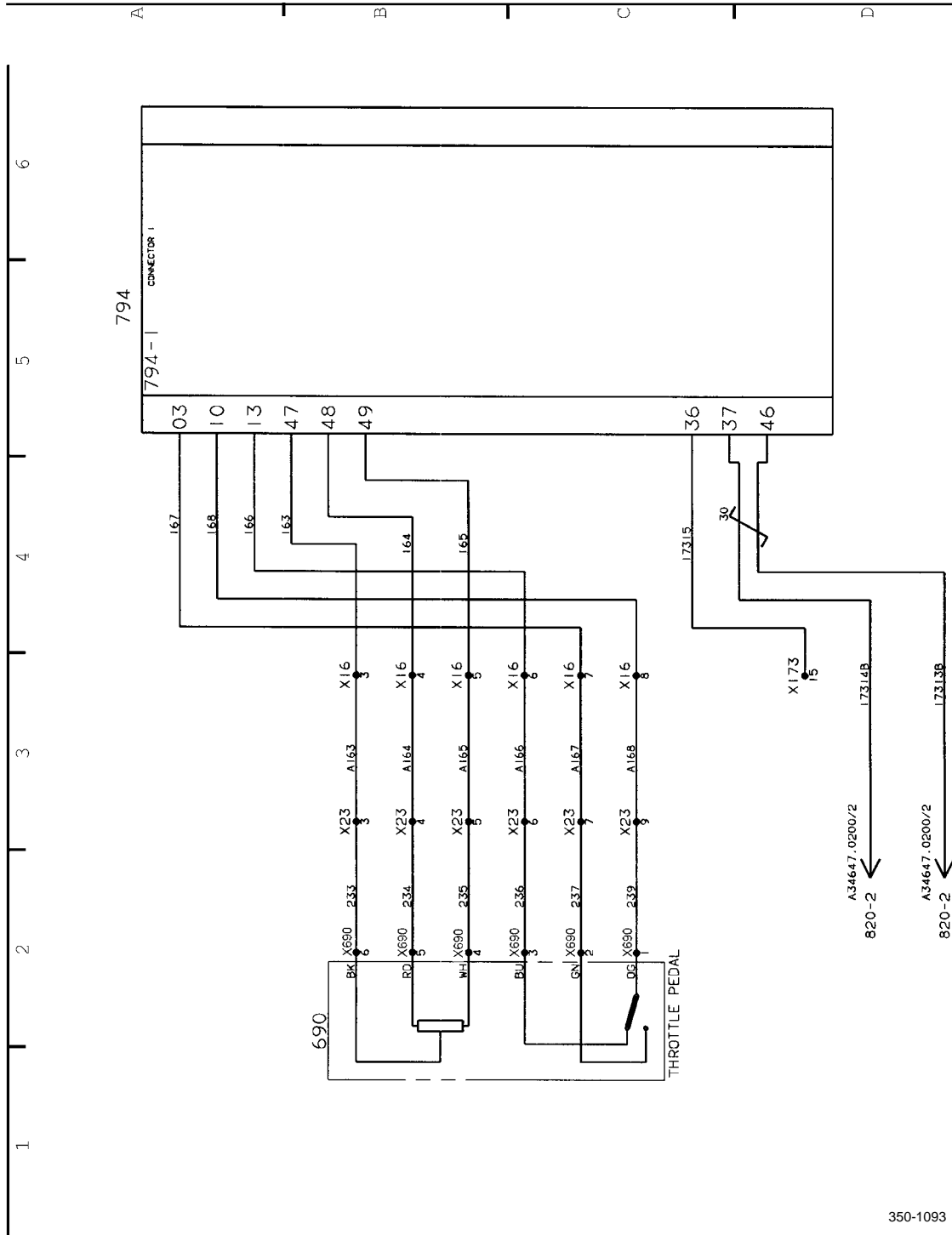


Figure 3. ECS Engine (A34649.0200) Page 2 of 2.

350-1093

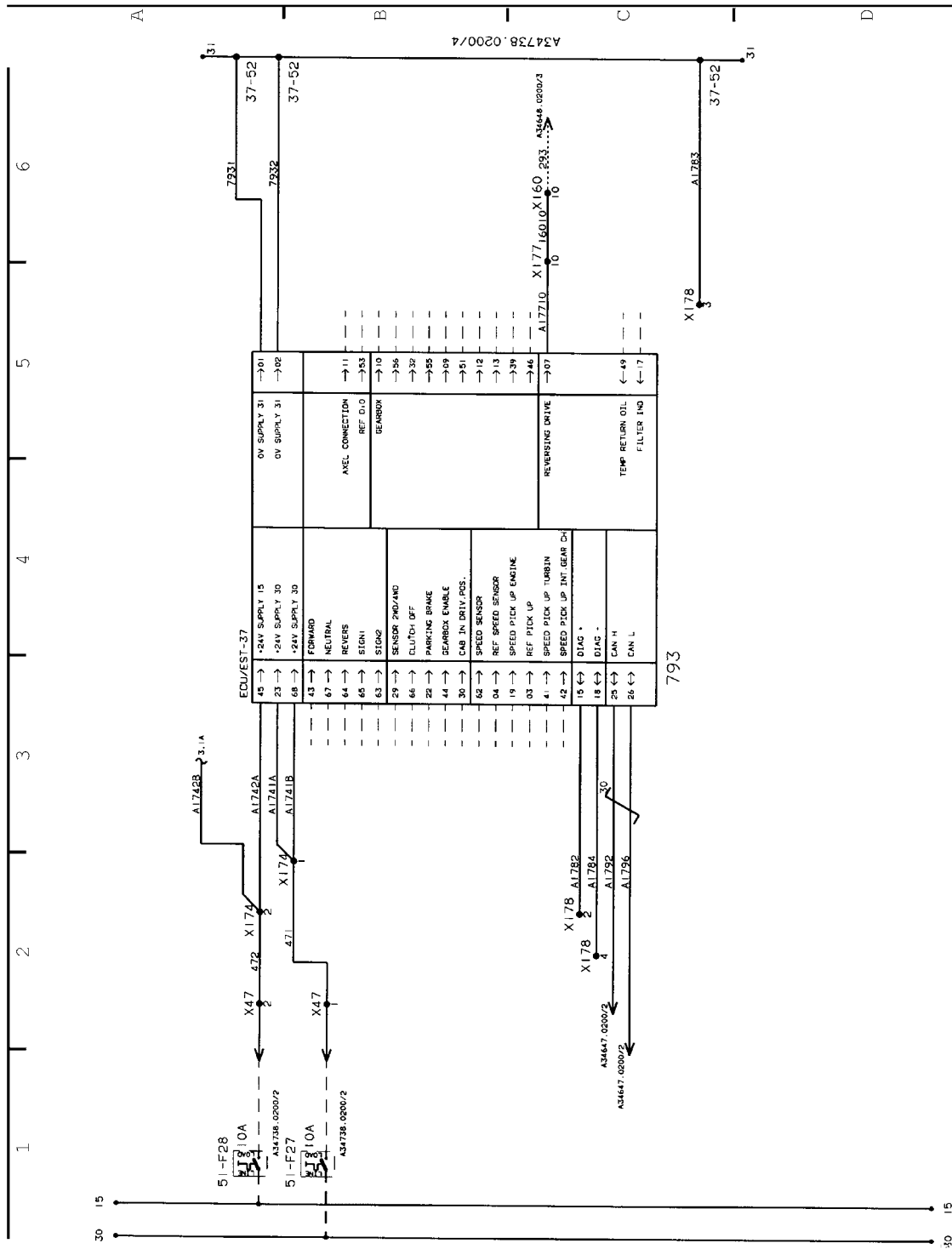


Figure 4. ECS Transmission (A34650.0200) Page 1 of 4.

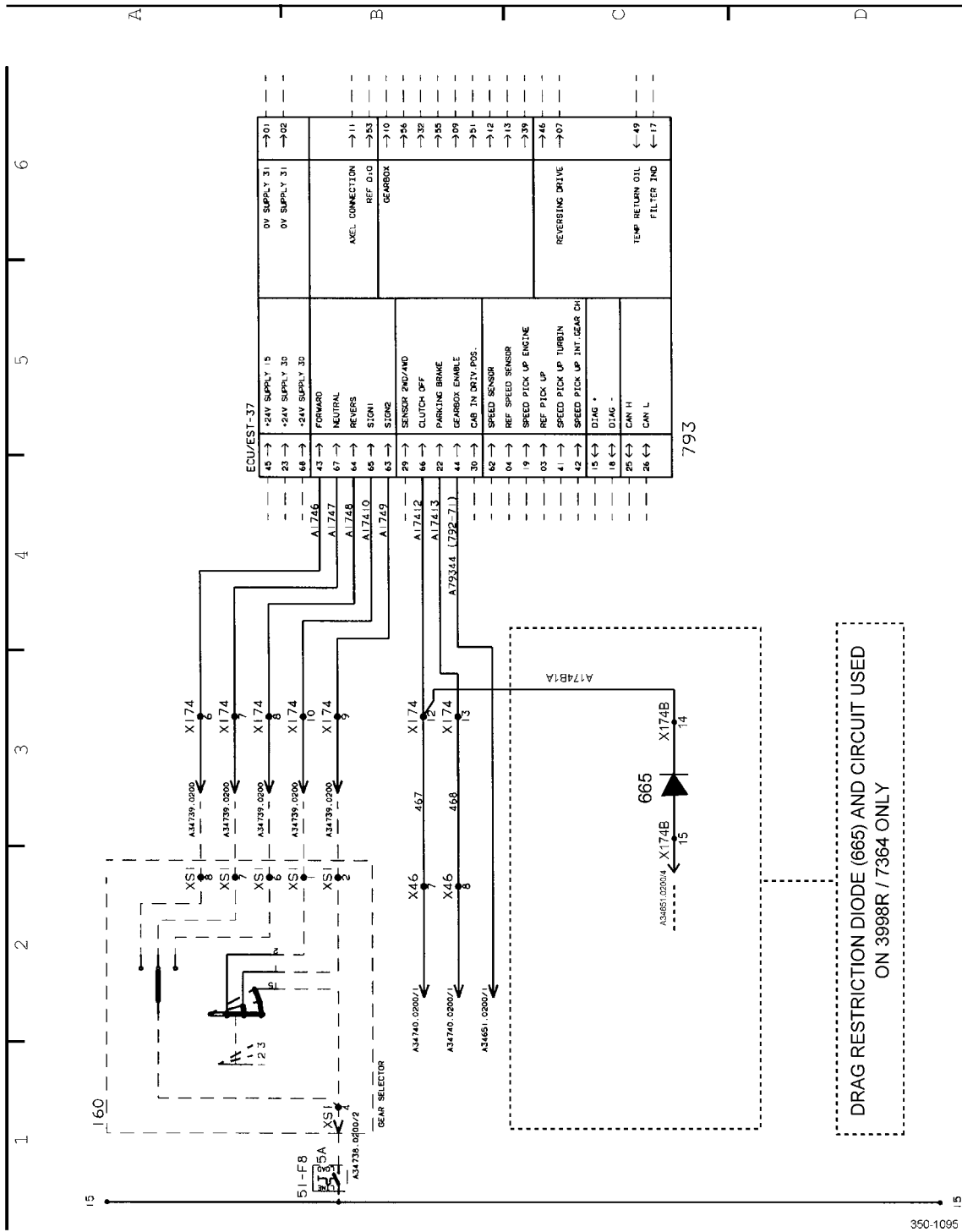
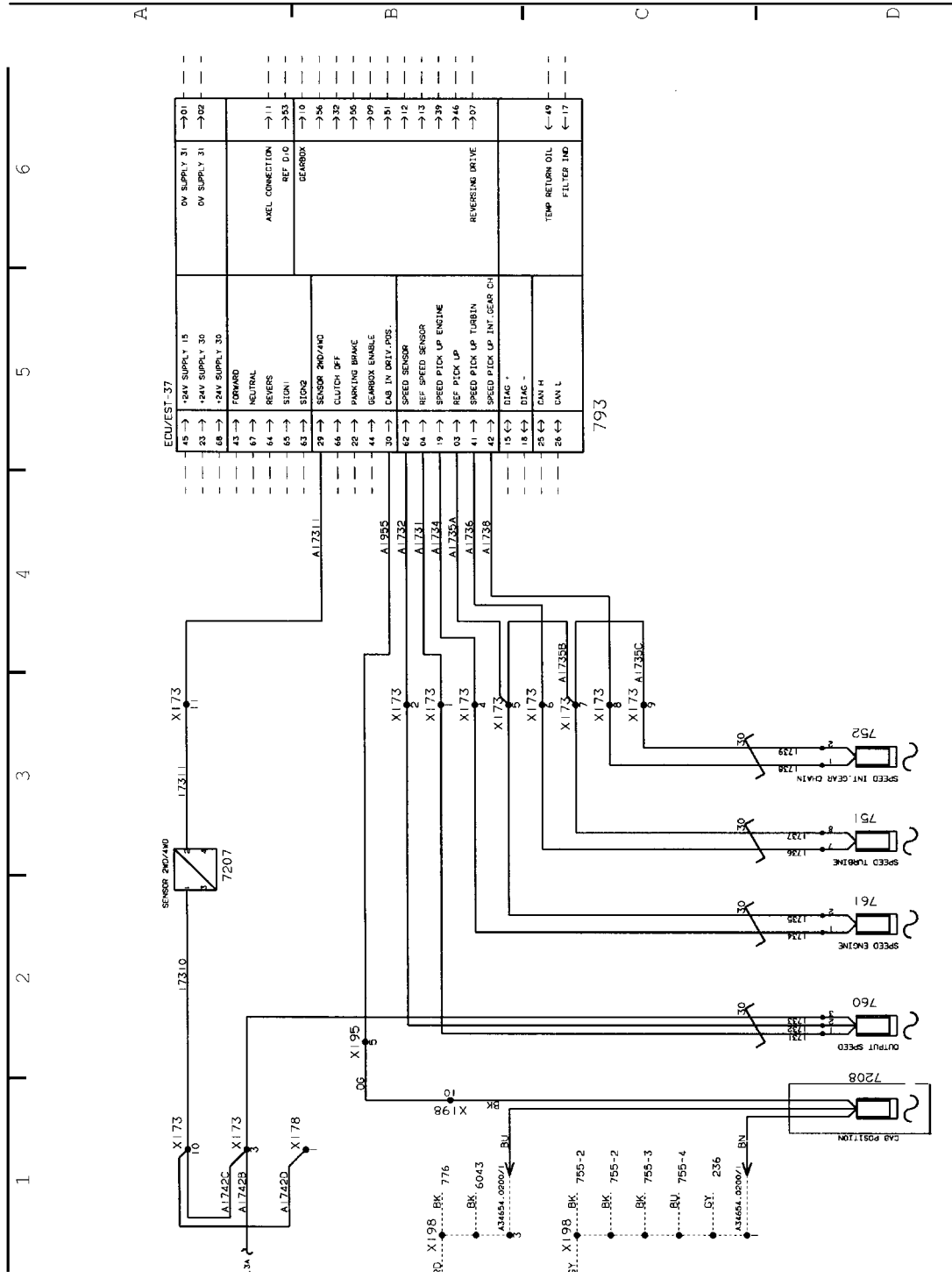


Figure 4. ECS Transmission (A34650.0200) Page 2 of 4.



350-1096

Figure 4. ECS Transmission (A34650.0200) Page 3 of 4.

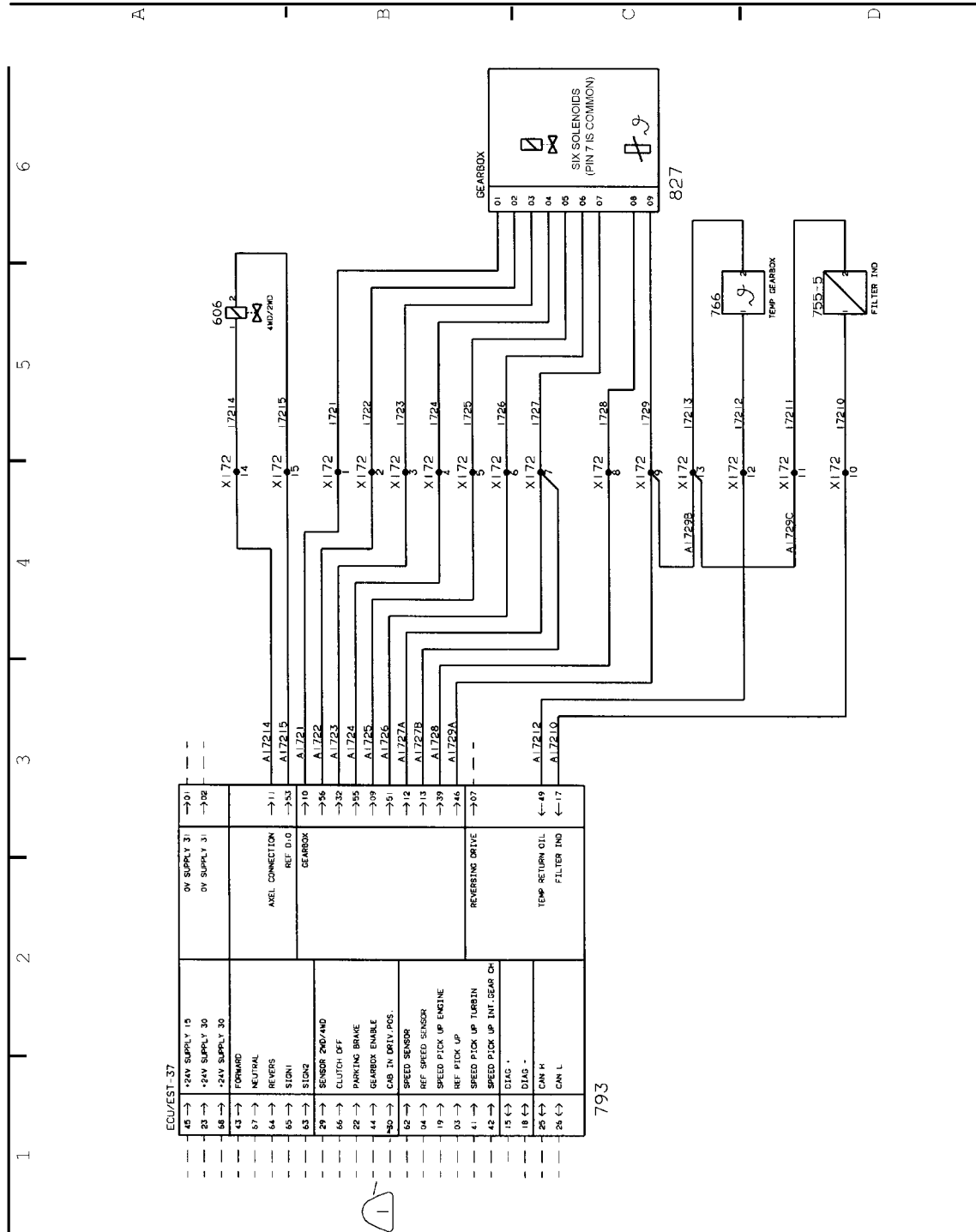


Figure 4. ECS Transmission (A34650.0200) Page 4 of 4.

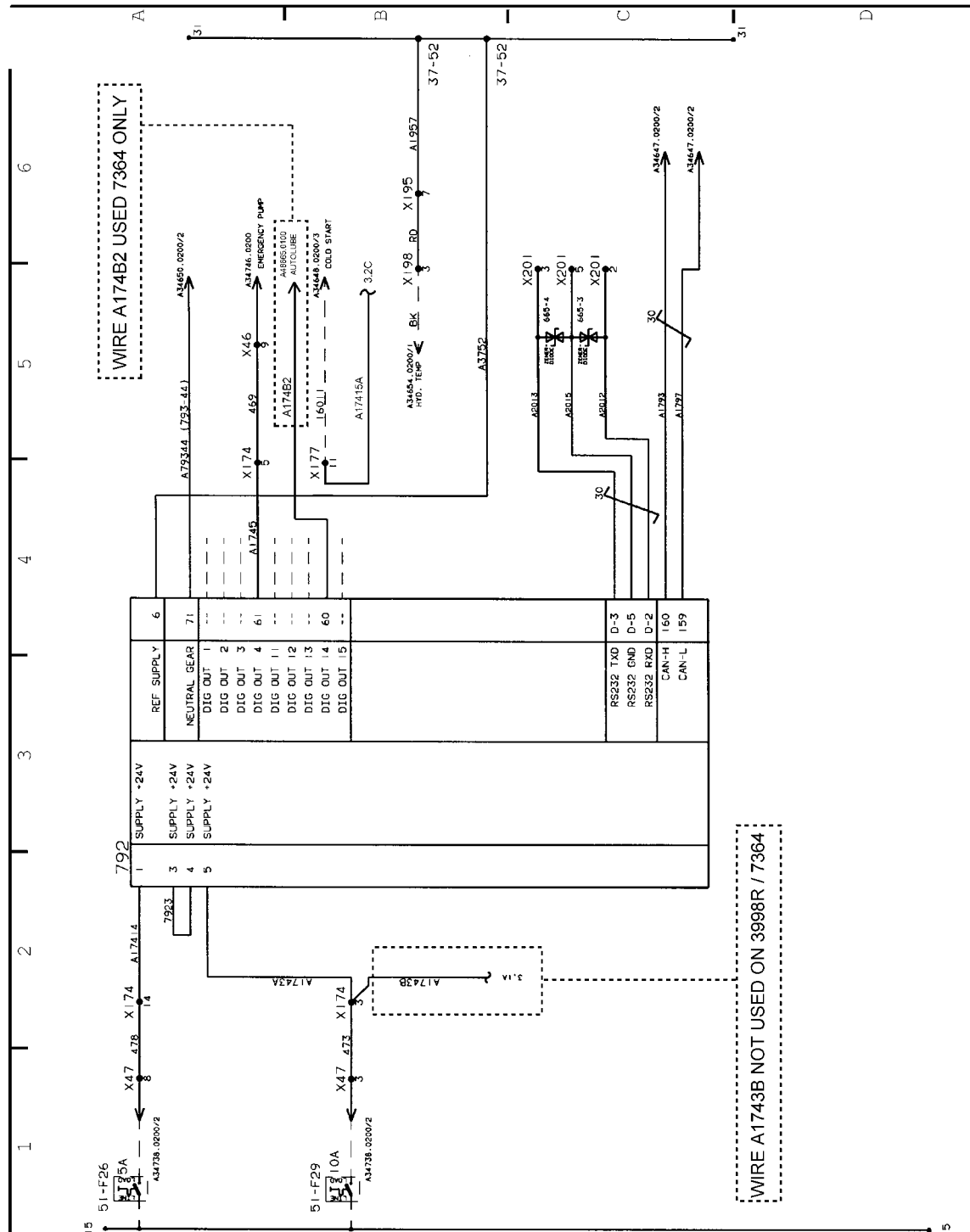


Figure 5. ECS Steering (A34651.0200) Page 1 of 7.

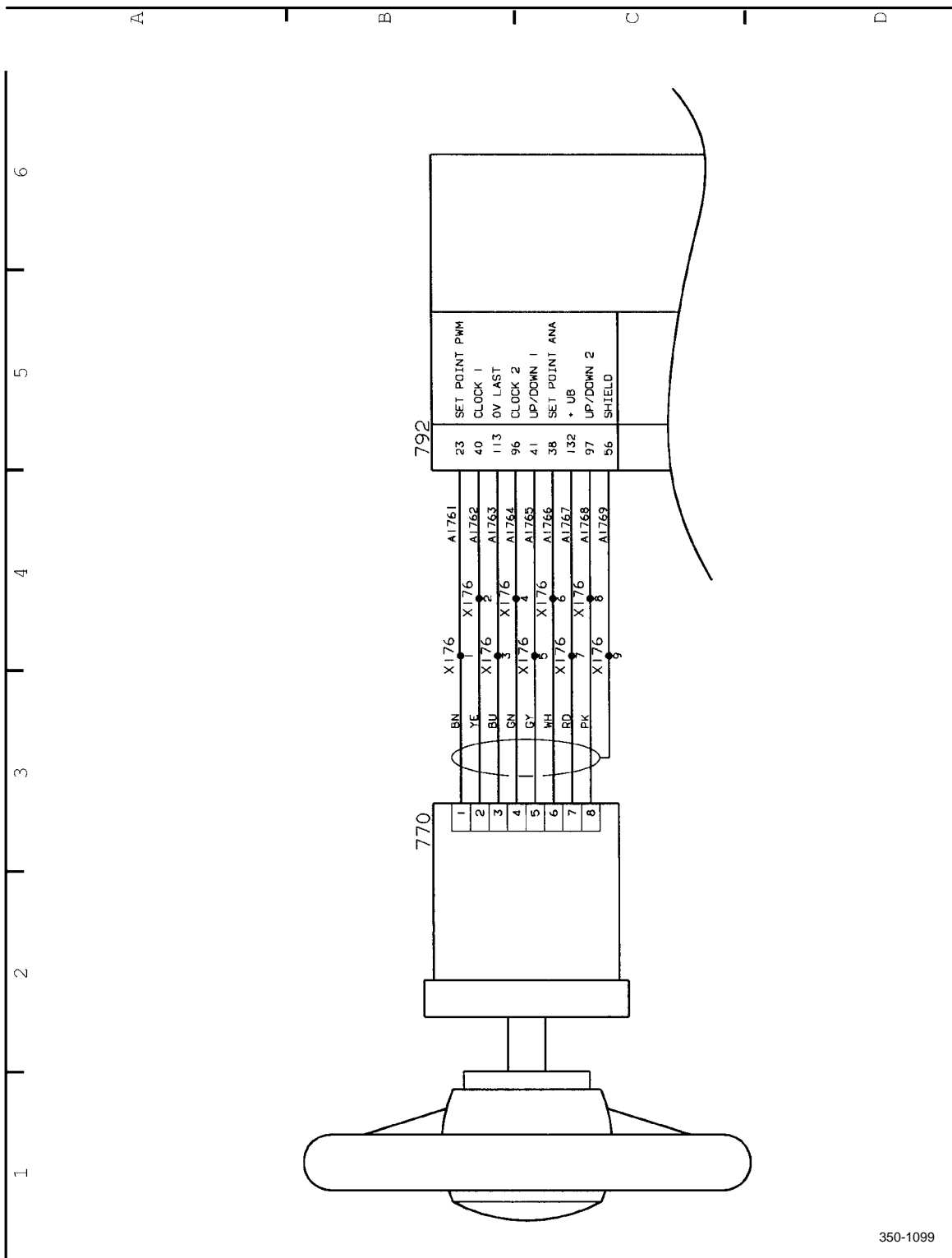


Figure 5. ECS Steering (A34651.0200) Page 2 of 7.

350-1099

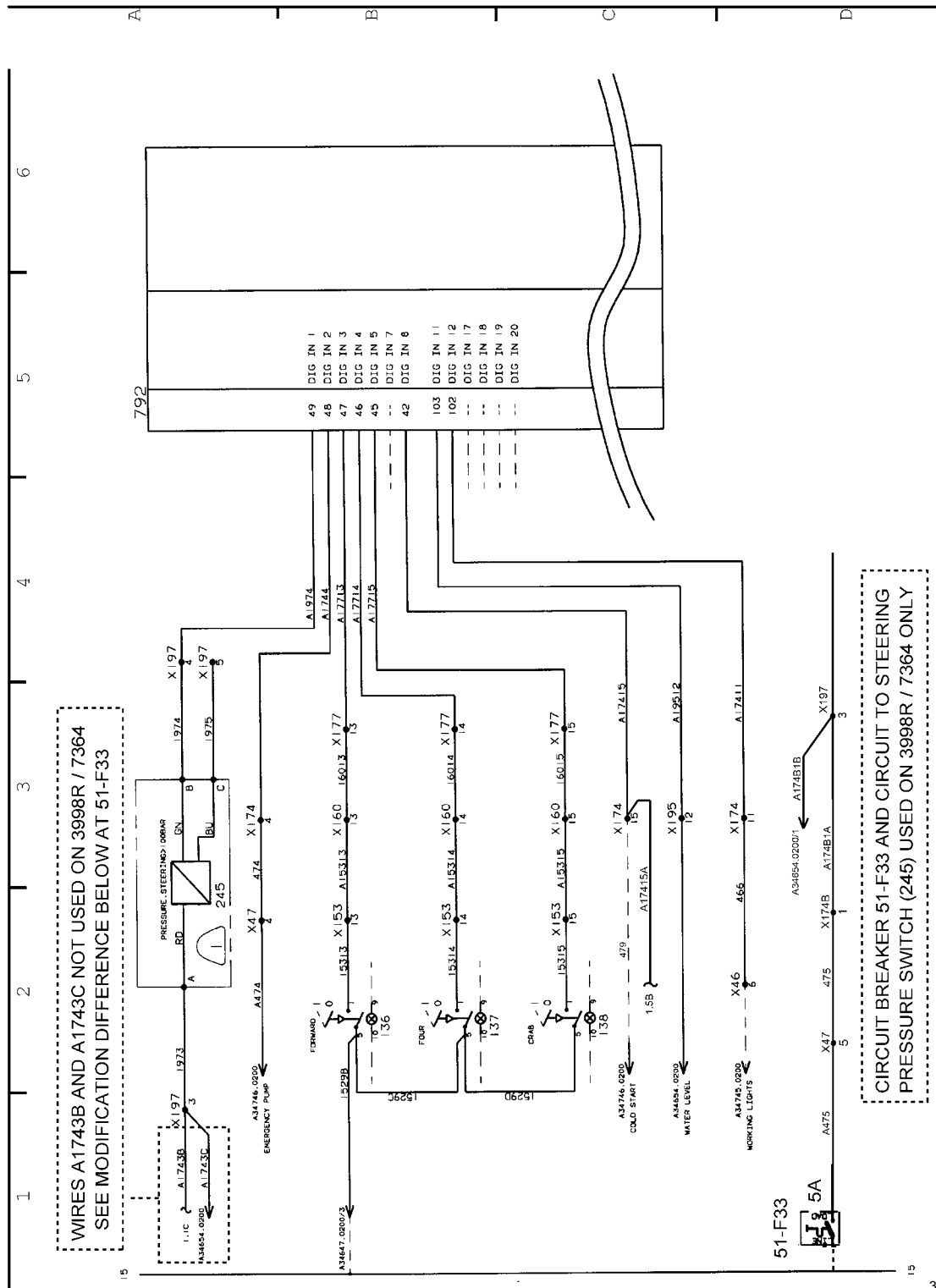


Figure 5. ECS Steering (A34651.0200) Page 3 of 7.

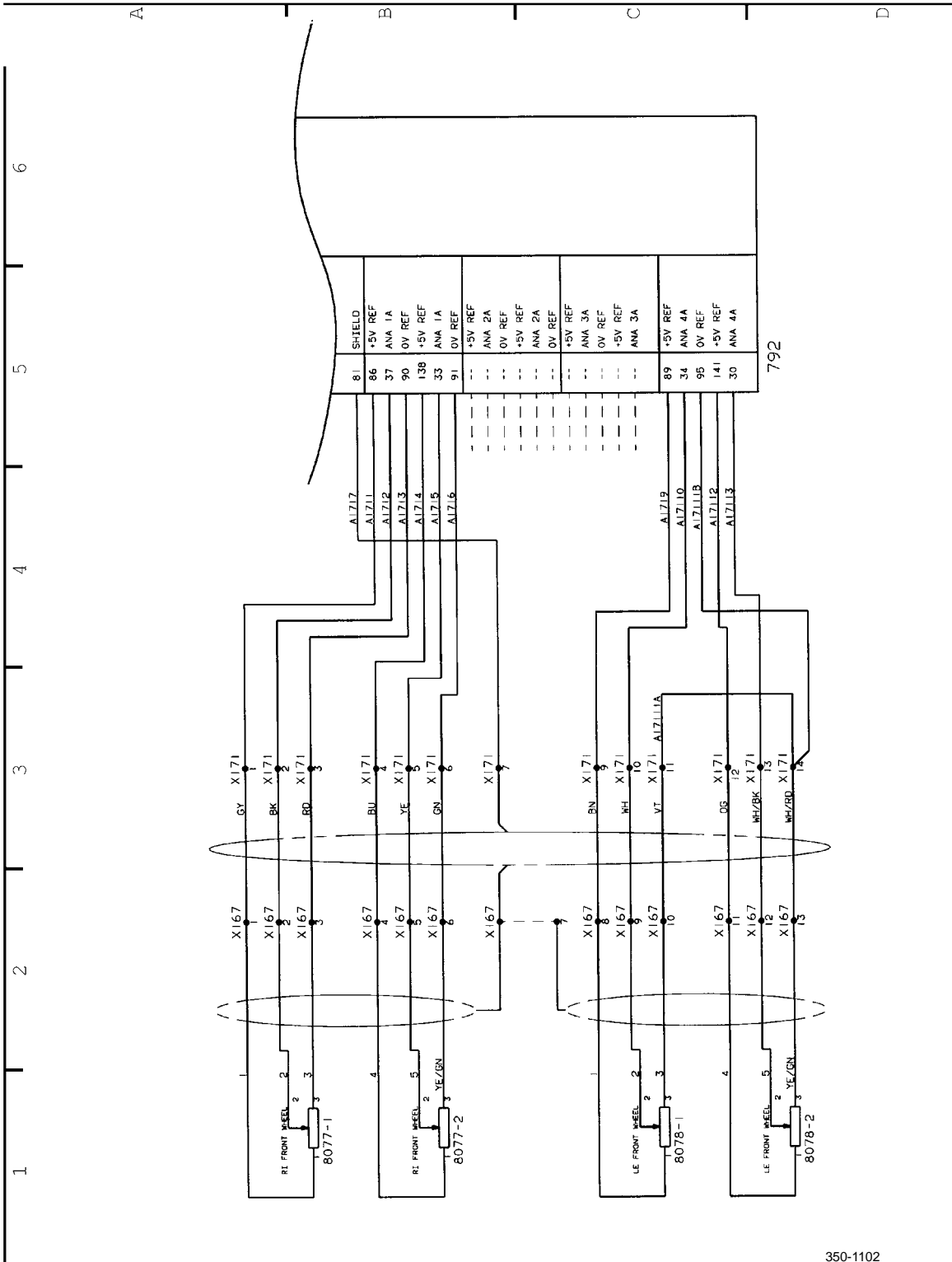
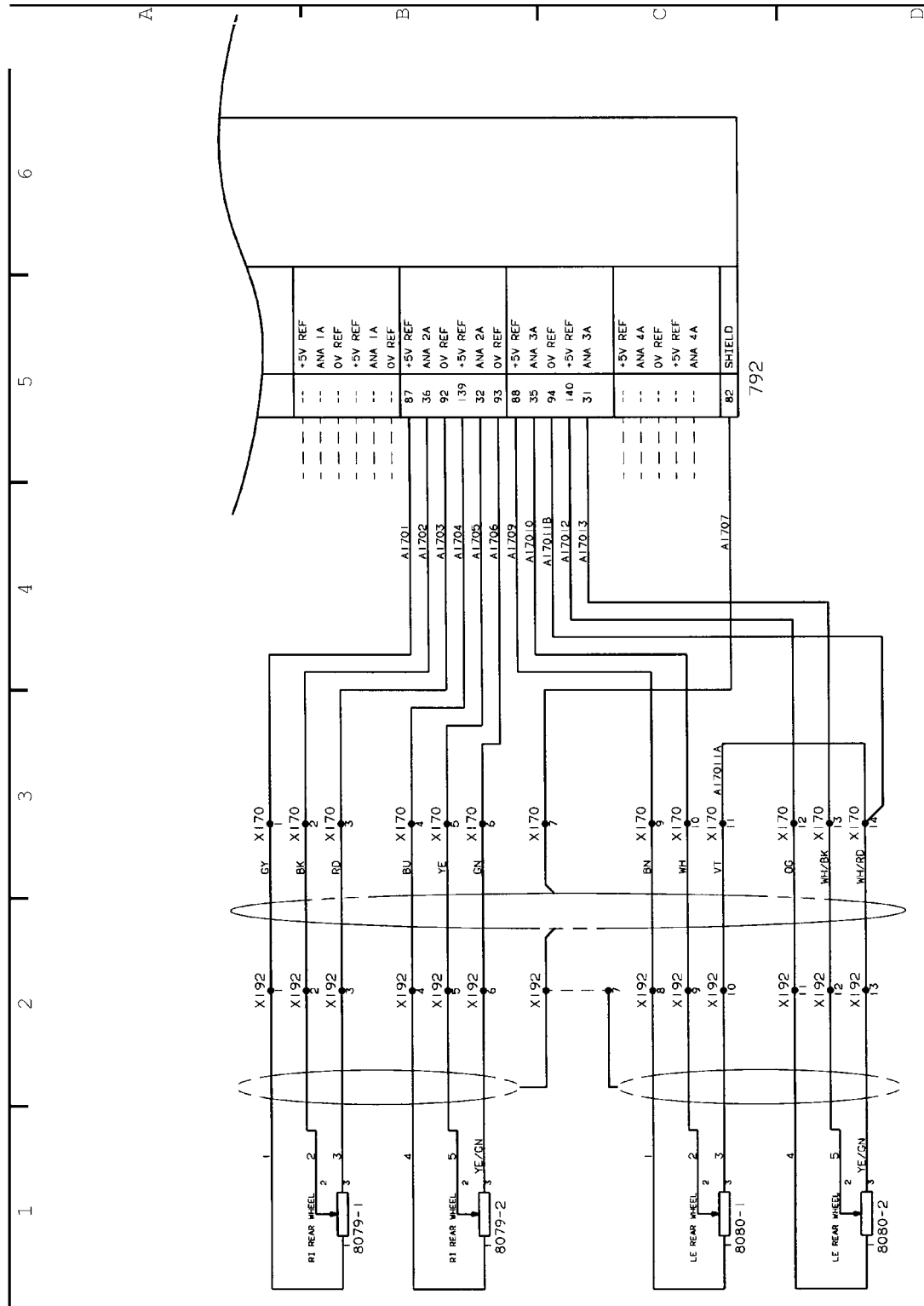


Figure 5. ECS Steering (A34651.0200) Page 5 of 7.

350-1102



350-1103

Figure 5. ECS Steering (A34651.0200) Page 6 of 7.

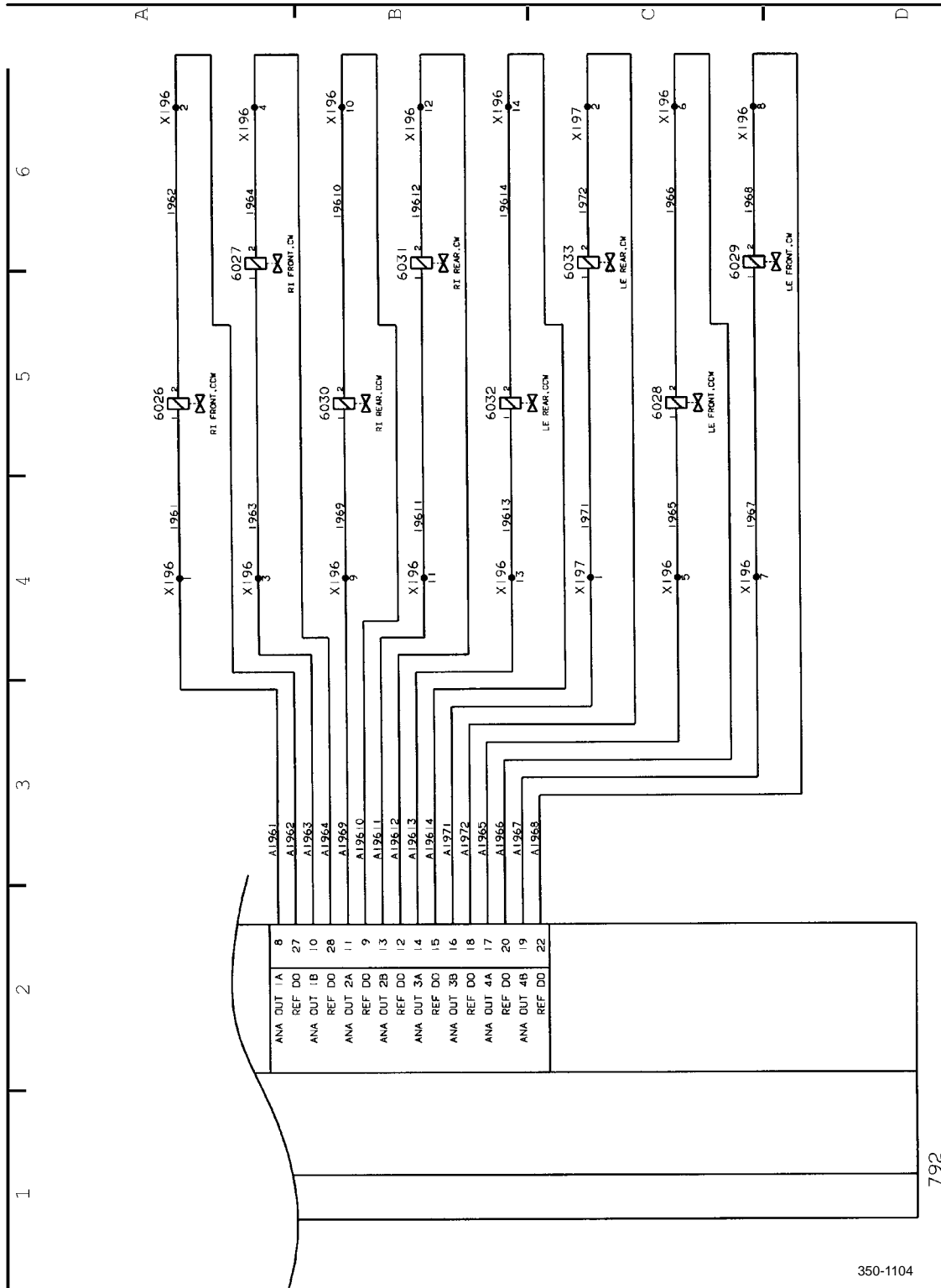
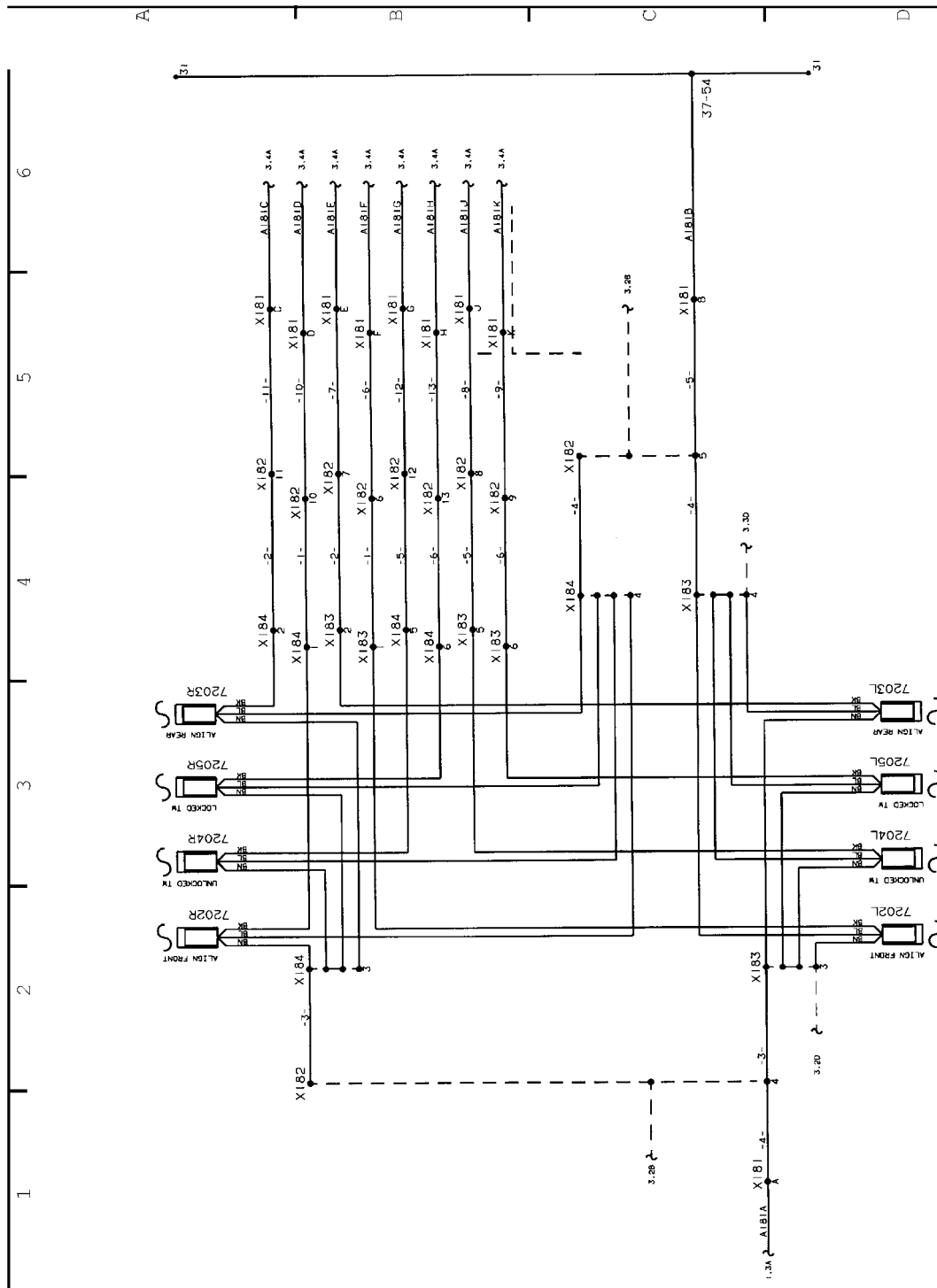


Figure 5. ECS Steering (A34651.0200) Page 7 of 7.



350-1106

Figure 6. ECS Attachment to Tophandler (A34652.0200) Page 2 of 6.

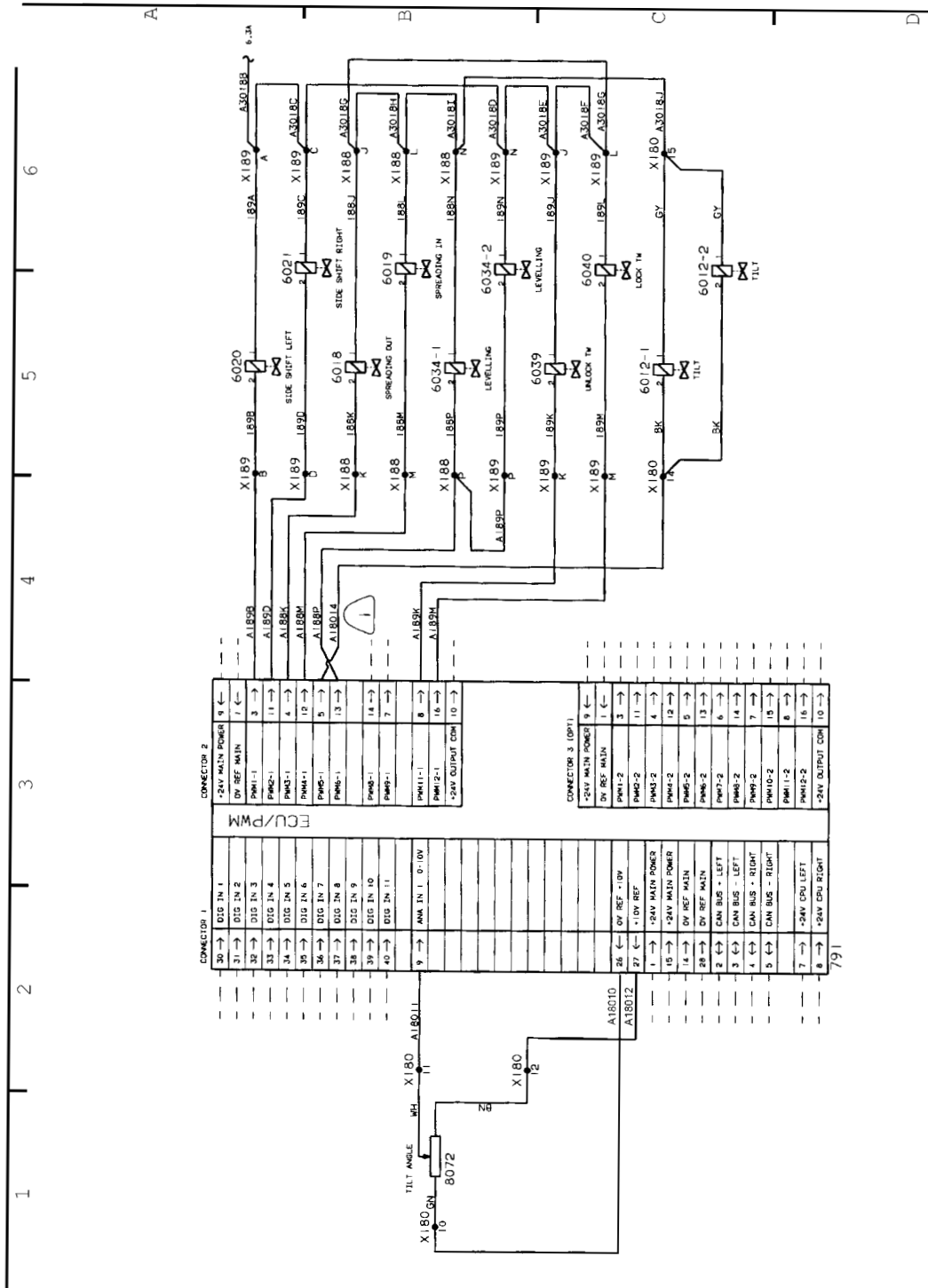


Figure 6. ECS Attachment to Tophandler (A34652.0200) Page 4 of 6.

350-1108

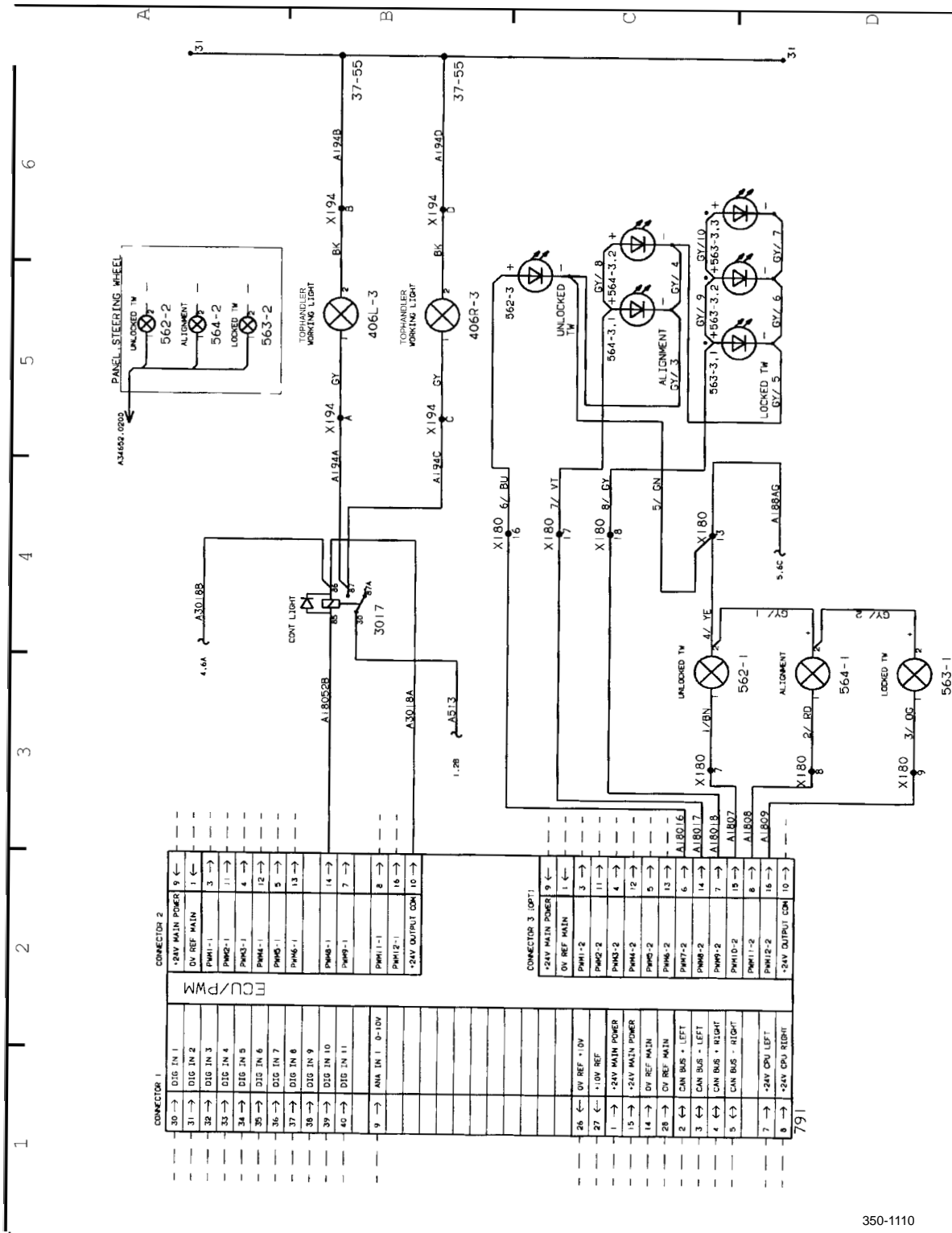


Figure 6. ECS Attachment to Tophandler (A34652.0200) Page 6 of 6.

350-1110

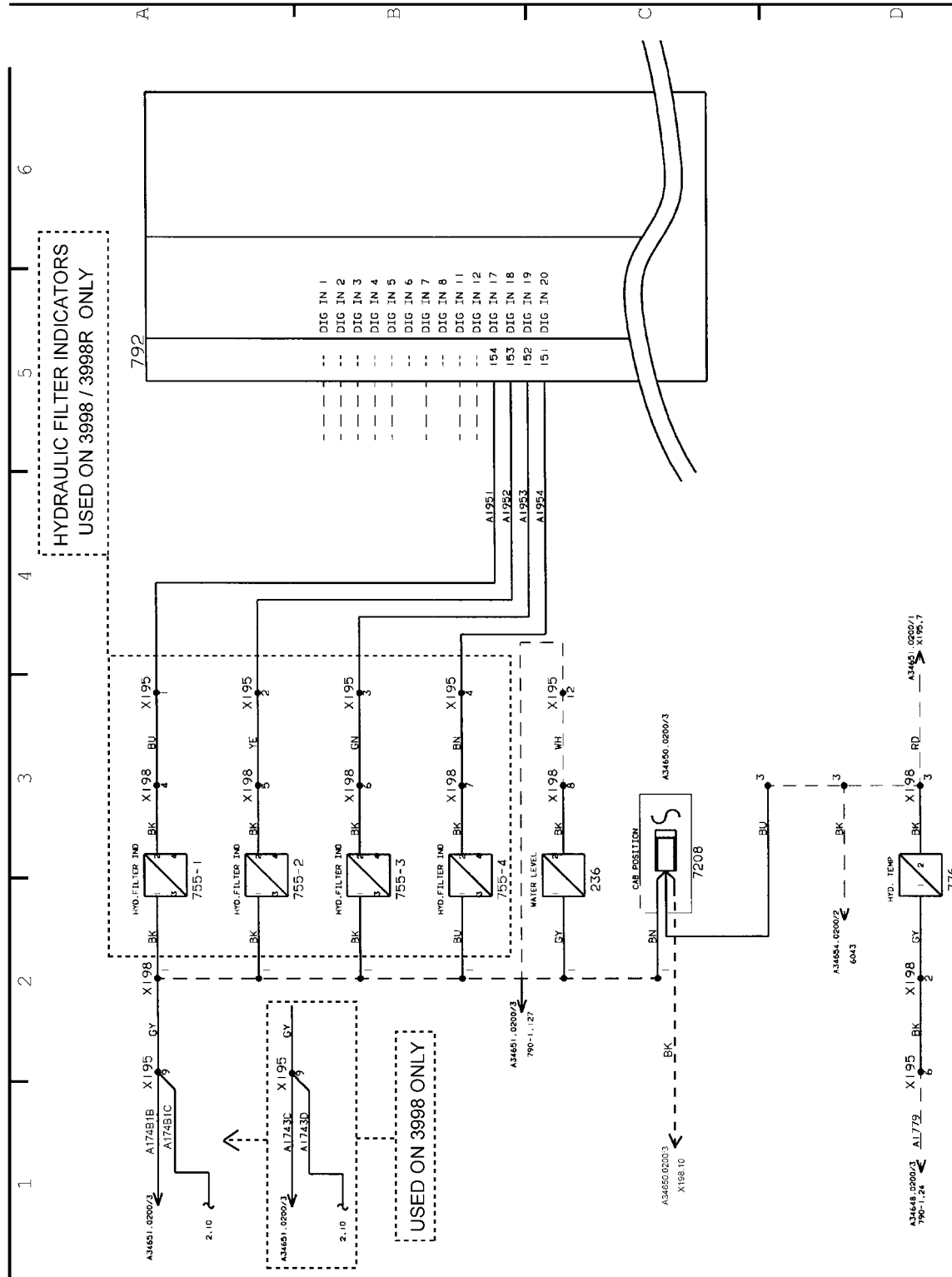


Figure 7. Hydraulics (A34654.0200) Page 1 of 2.

350-1111

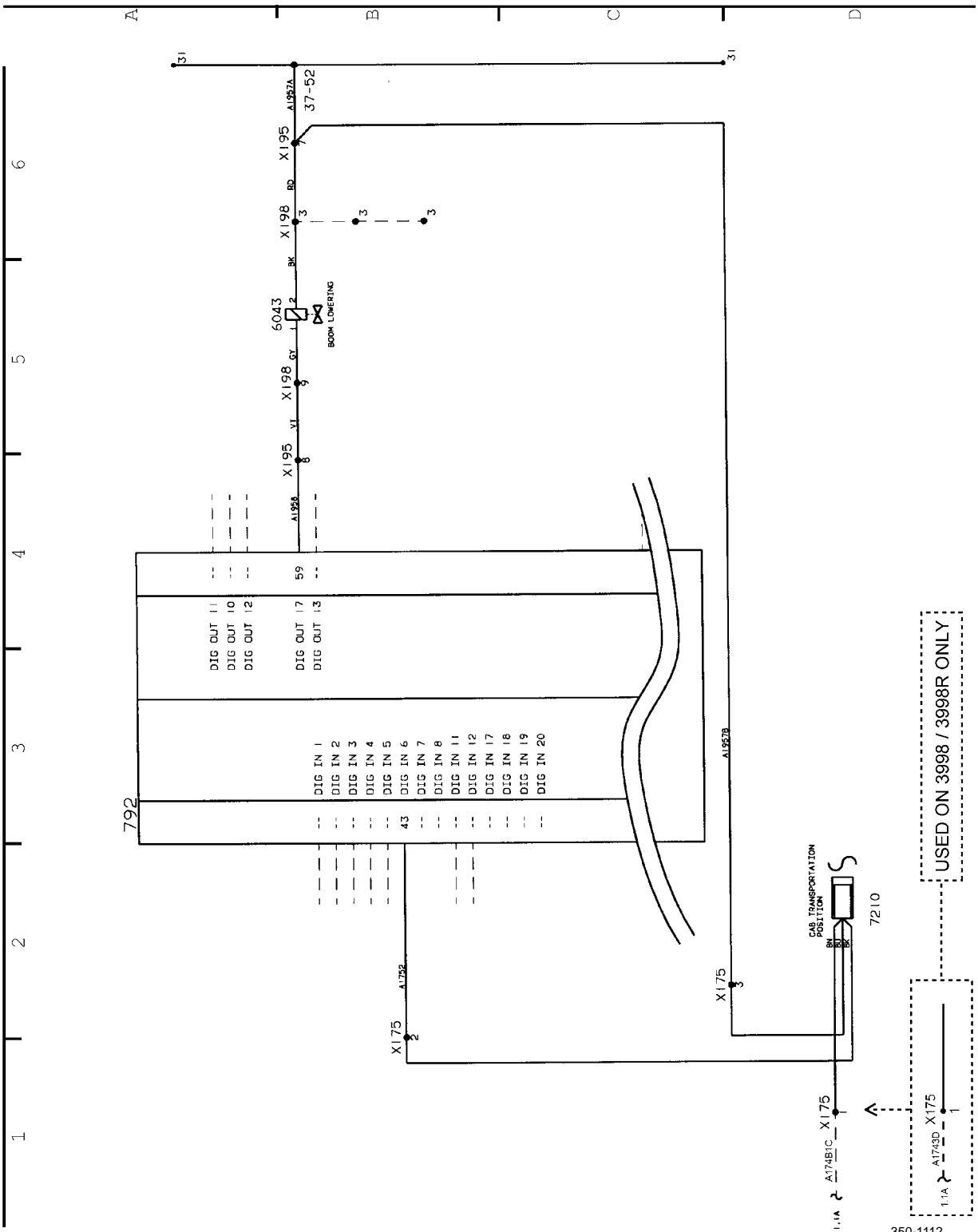


Figure 7. Hydraulics (A34654.0200) Page 2 of 2.

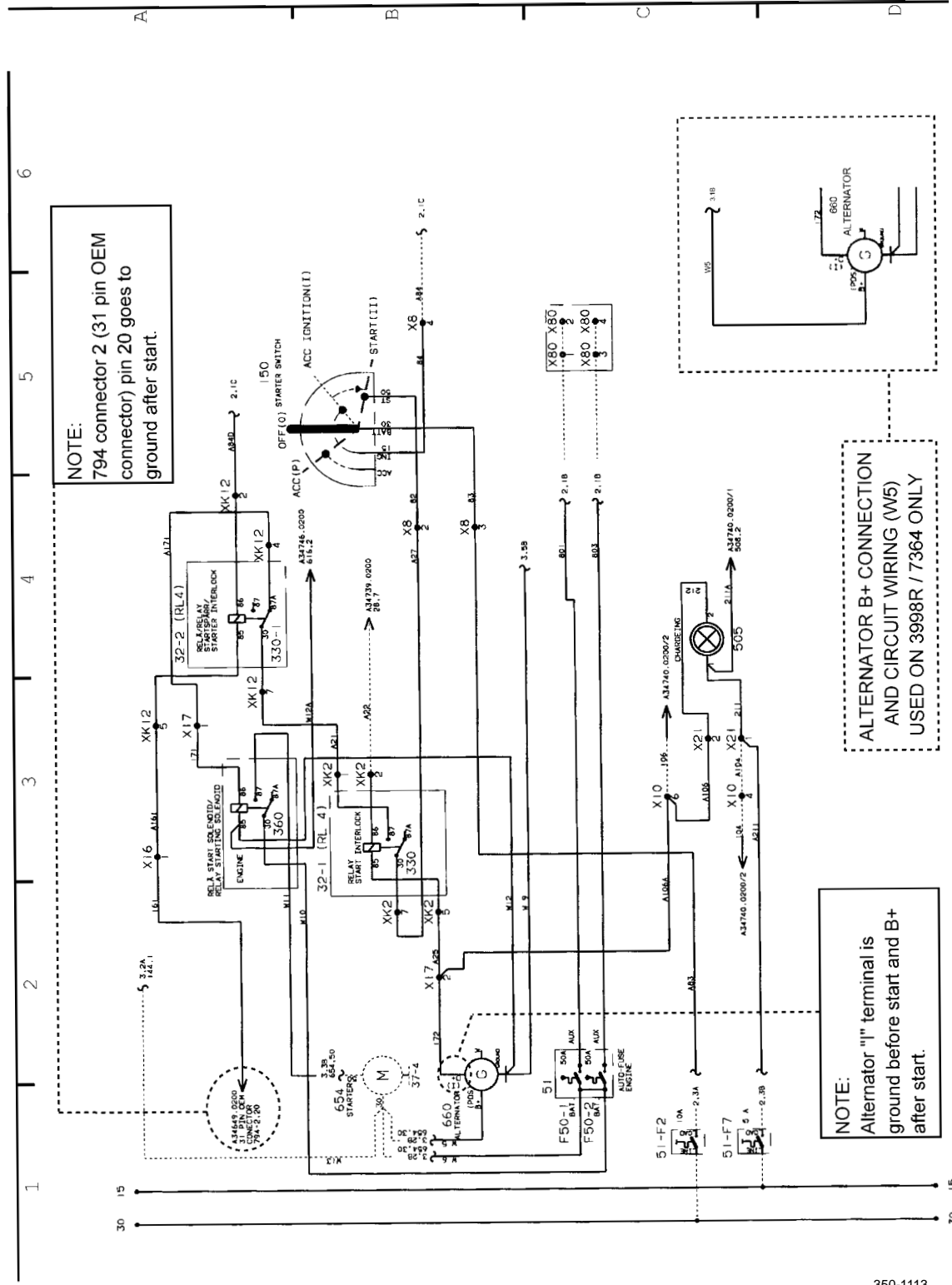
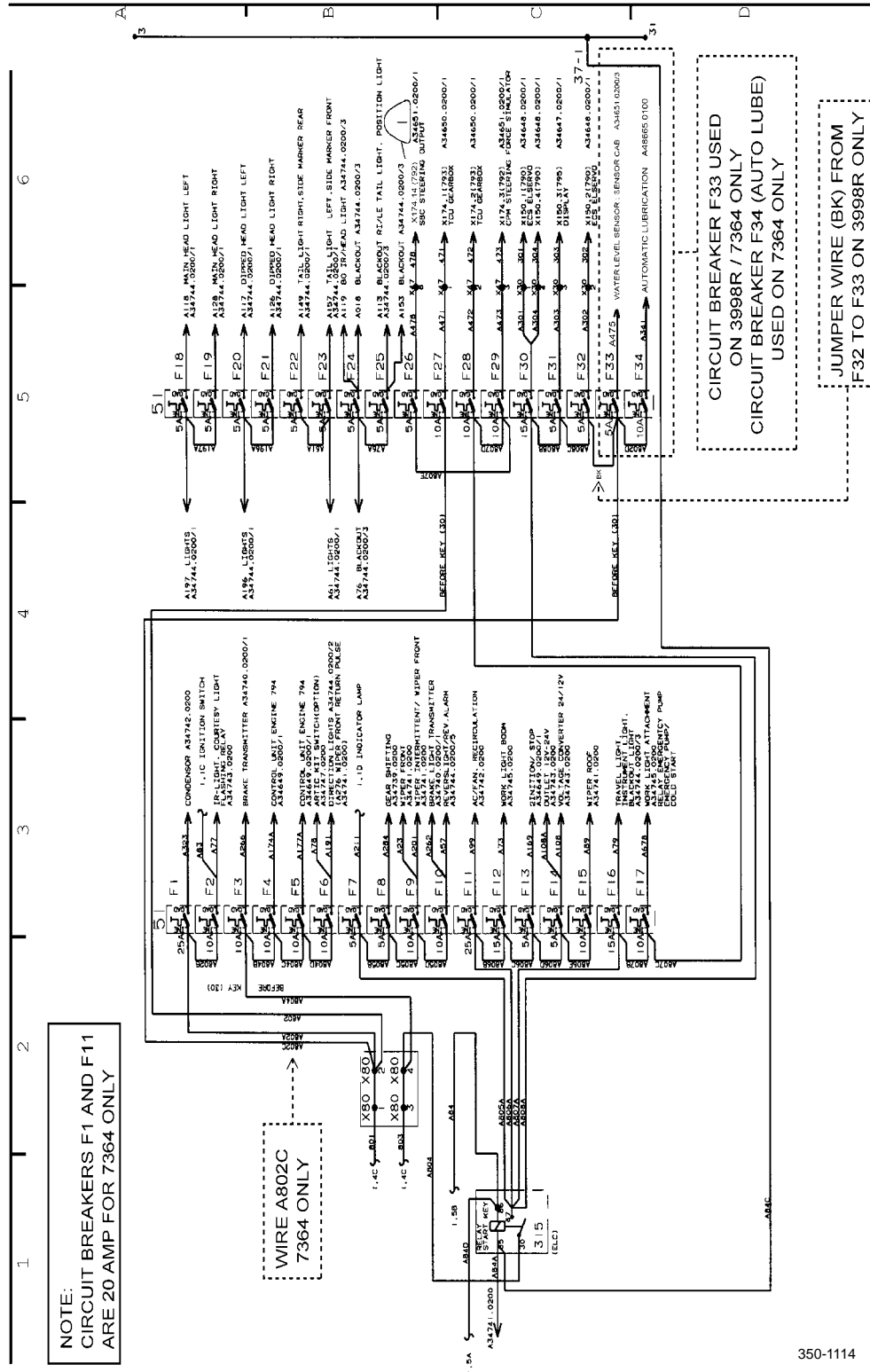


Figure 8. Current Supply (A34738.0200) Page 1 of 4.

350-1113



NOTE:
CIRCUIT BREAKERS F1 AND F11
ARE 20 AMP FOR 7364 ONLY

WIRE A802C
7364 ONLY

CIRCUIT BREAKER F33 USED
ON 3998R / 7364 ONLY

CIRCUIT BREAKER F34 (AUTO LUBE)
USED ON 7364 ONLY

JUMPER WIRE (BK) FROM
F32 TO F33 ON 3998R ONLY

350-1114

Figure 8. Current Supply (A34738.0200) Page 2 of 4.

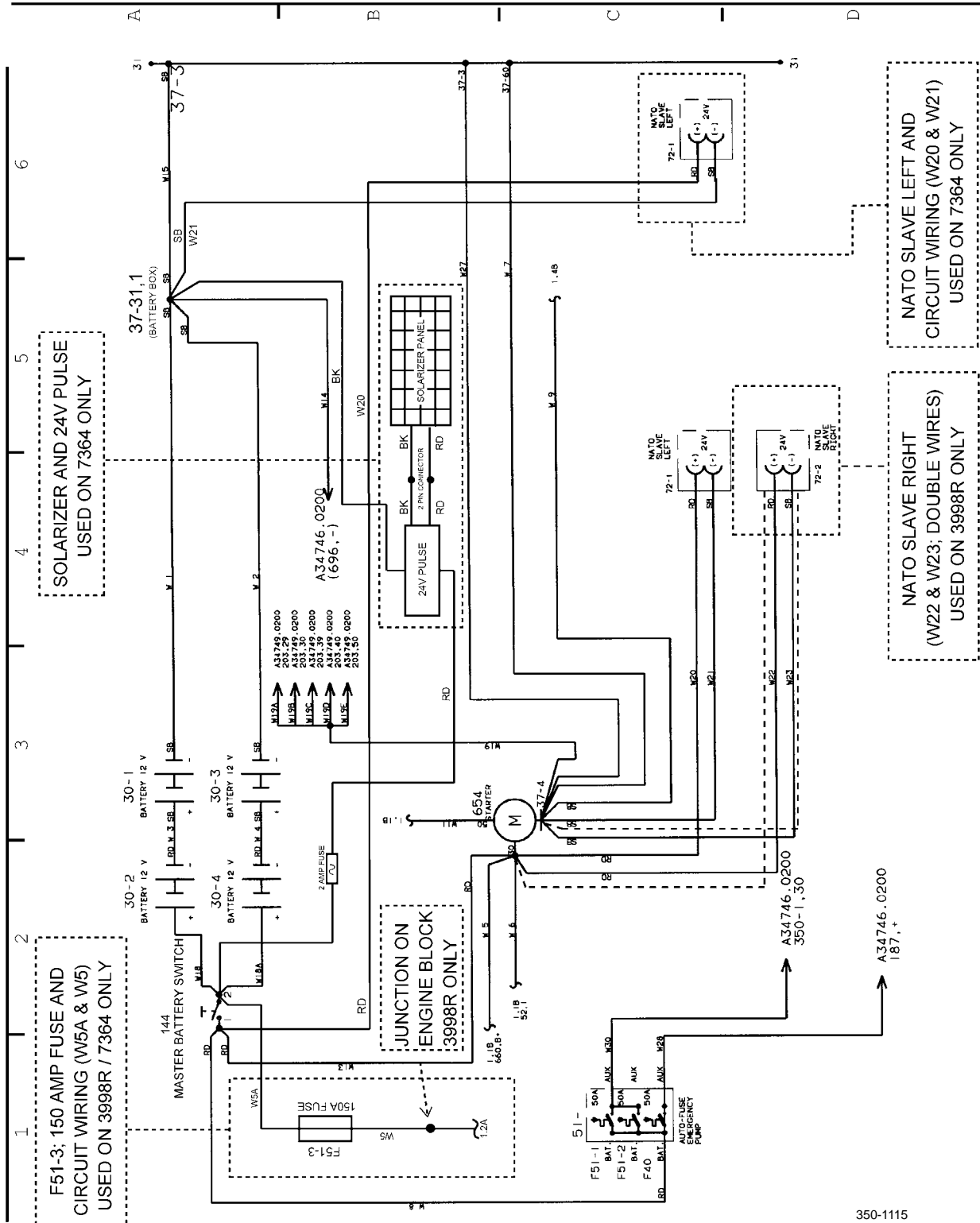


Figure 8. Current Supply (A34738.0200) Page 3 of 4.

350-1115

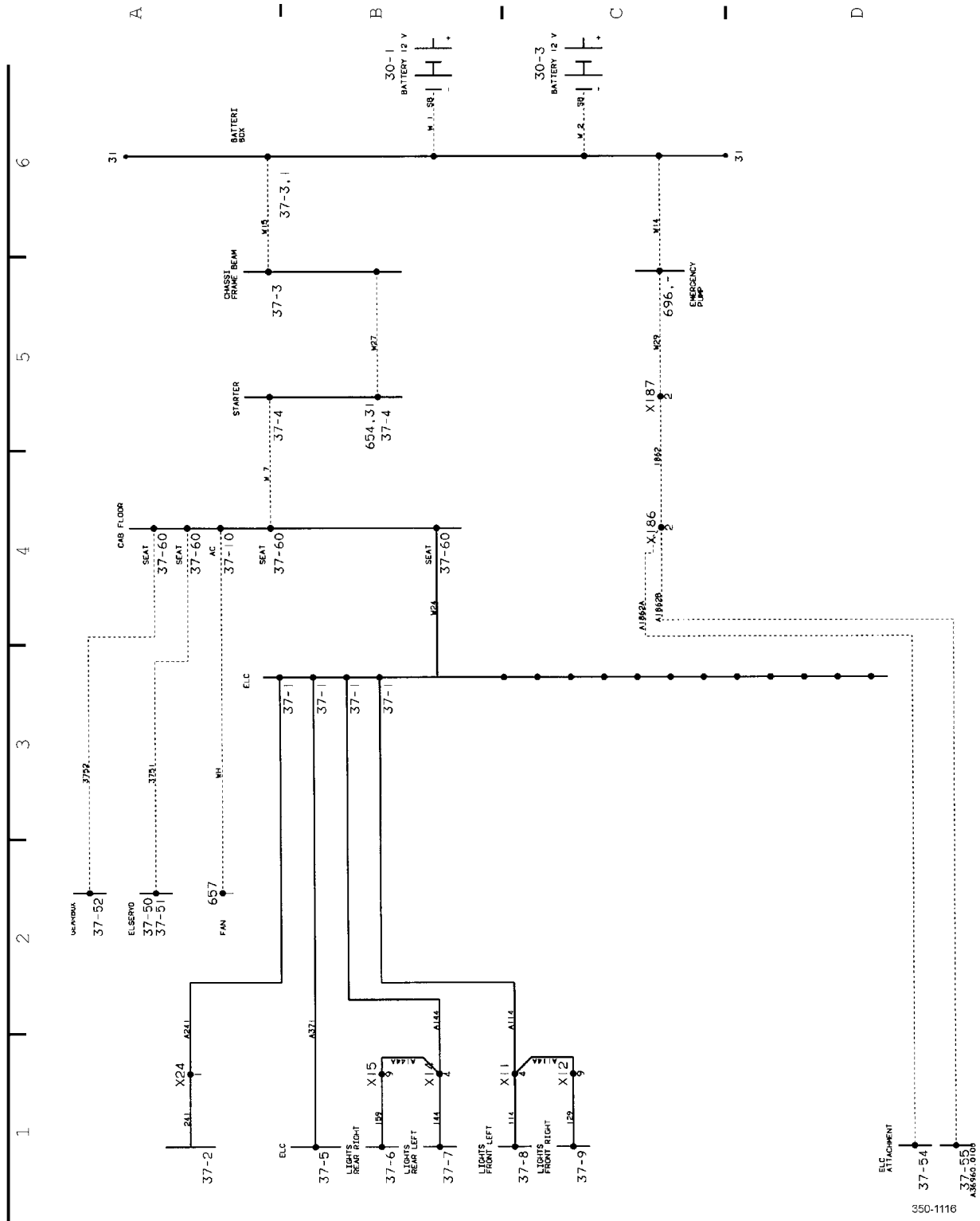


Figure 8. Current Supply (A34738.0200) Page 4 of 4.

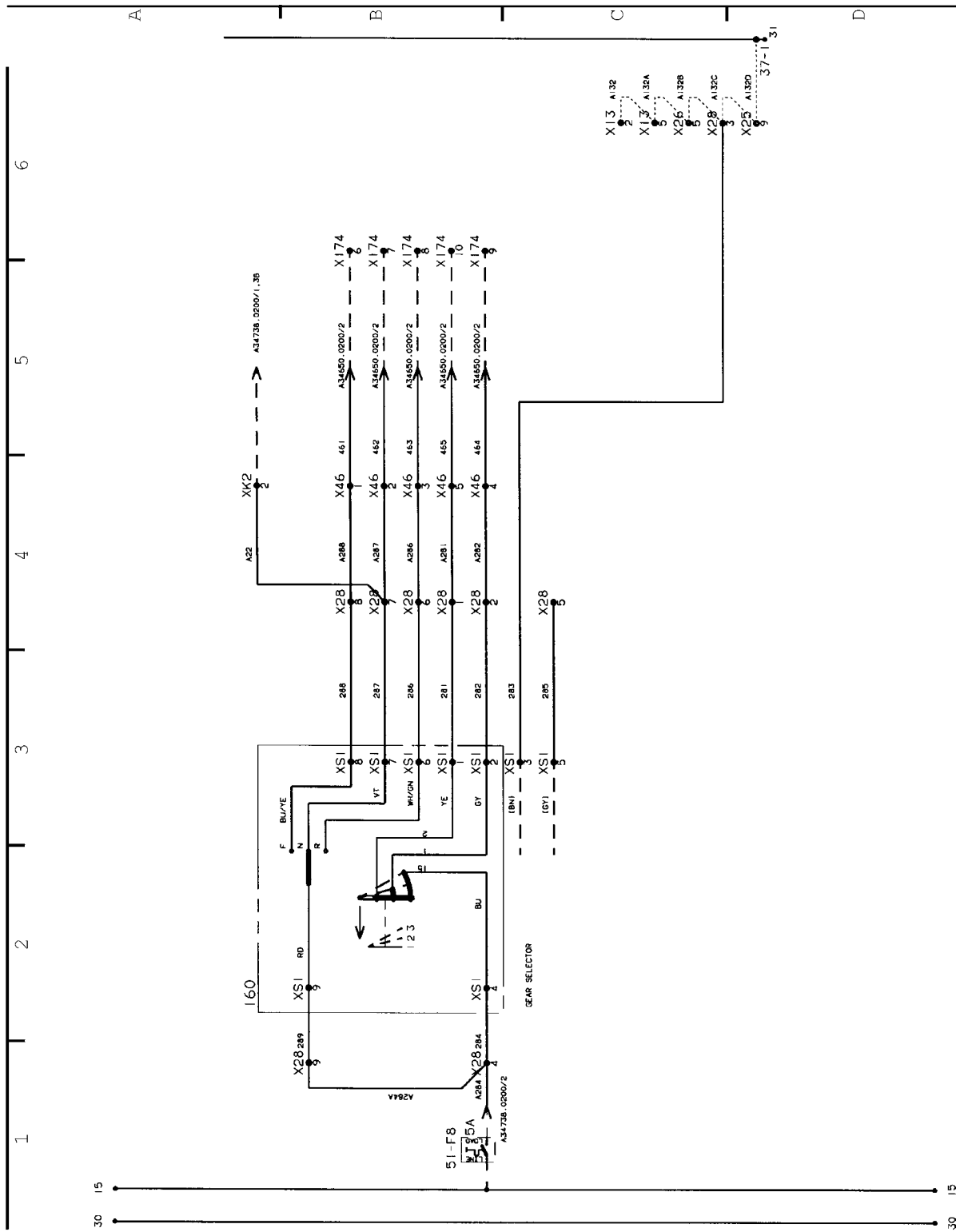


Figure 9. Shifting (A34739.0200) Page 1 of 1.

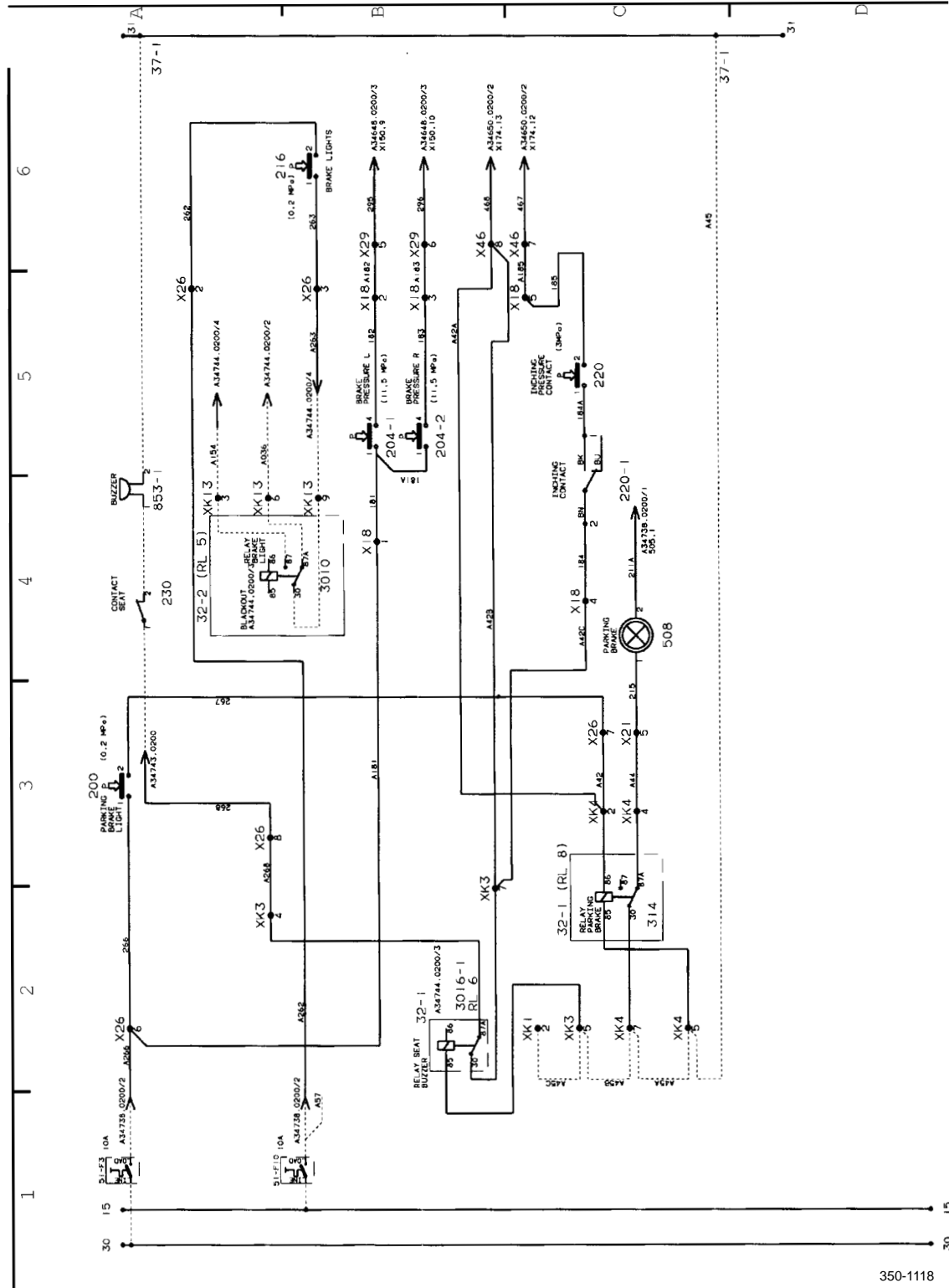


Figure 10. Sender (A34740.0200) Page 1 of 2.

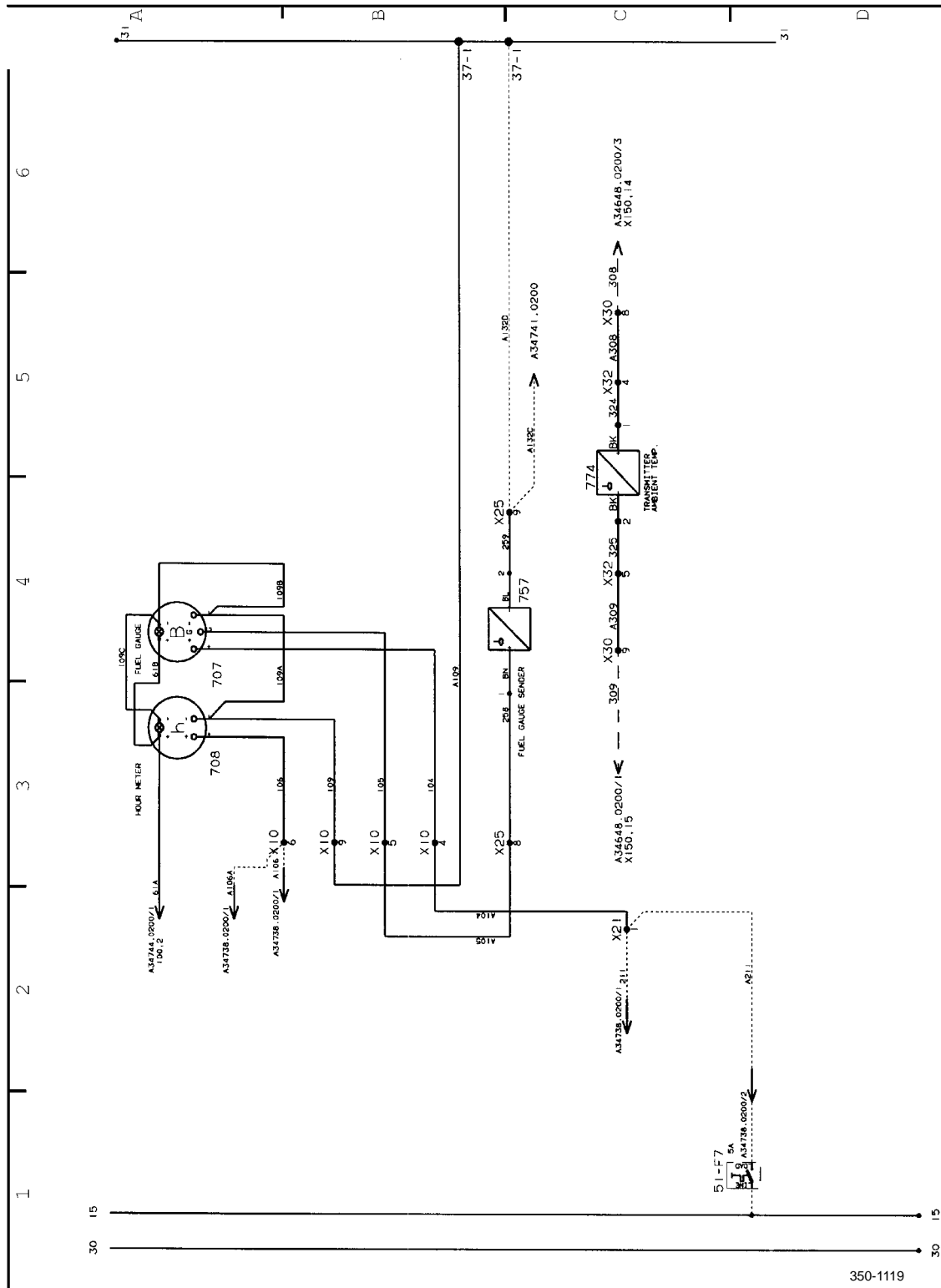


Figure 10. Sender (A34740.0200) Page 2 of 2.

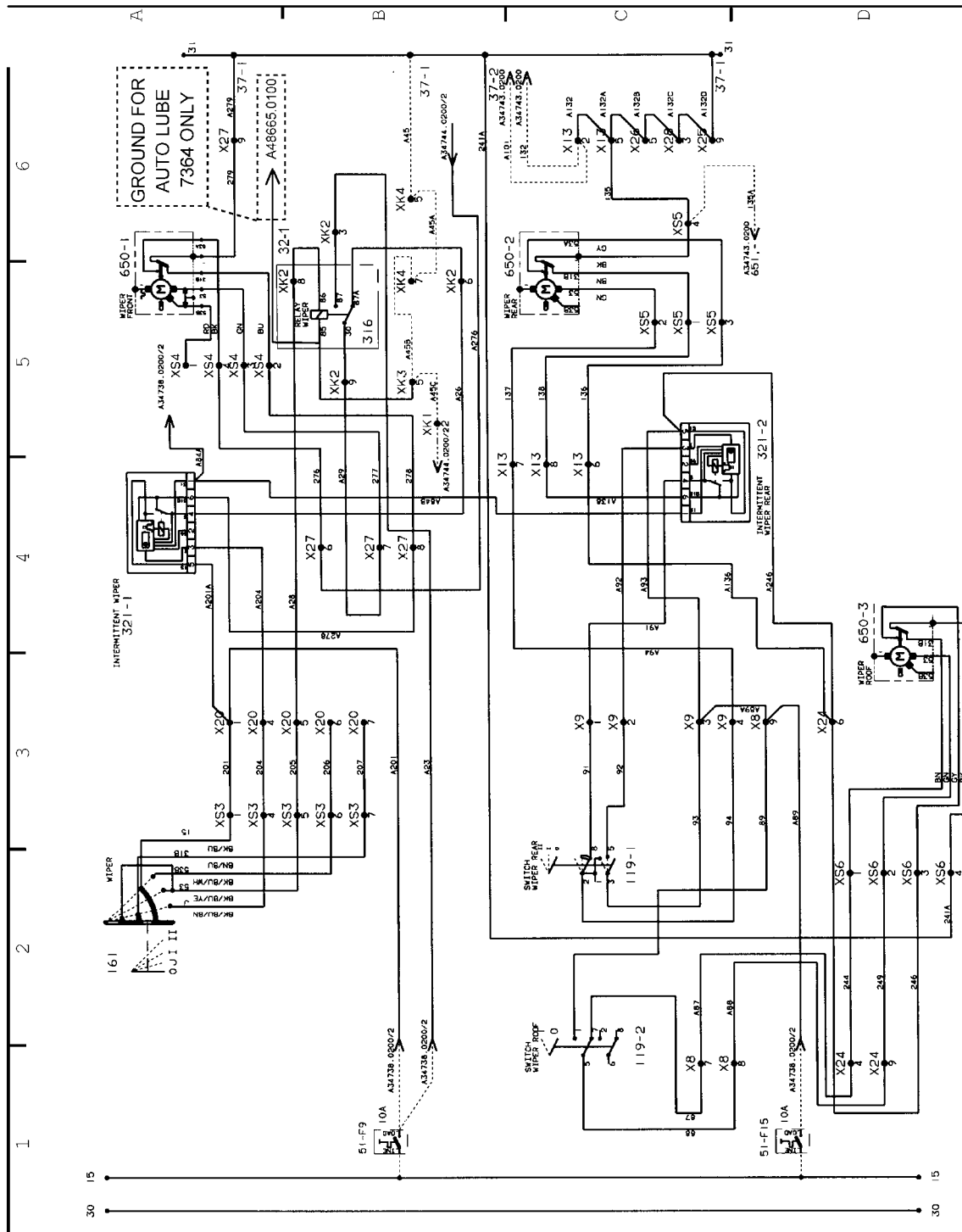


Figure 11. Wipers (A34741.0200) Page 1 of 1.

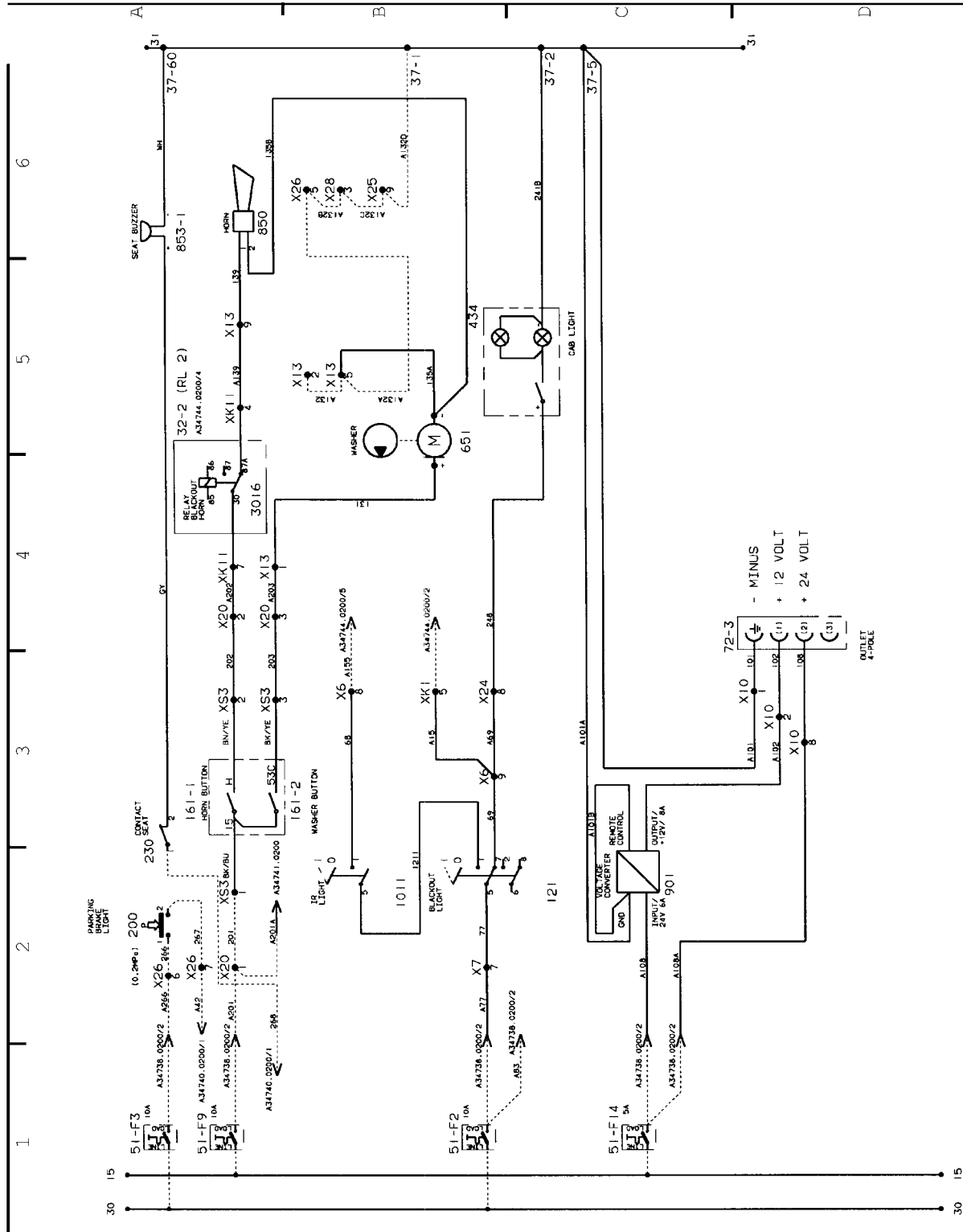
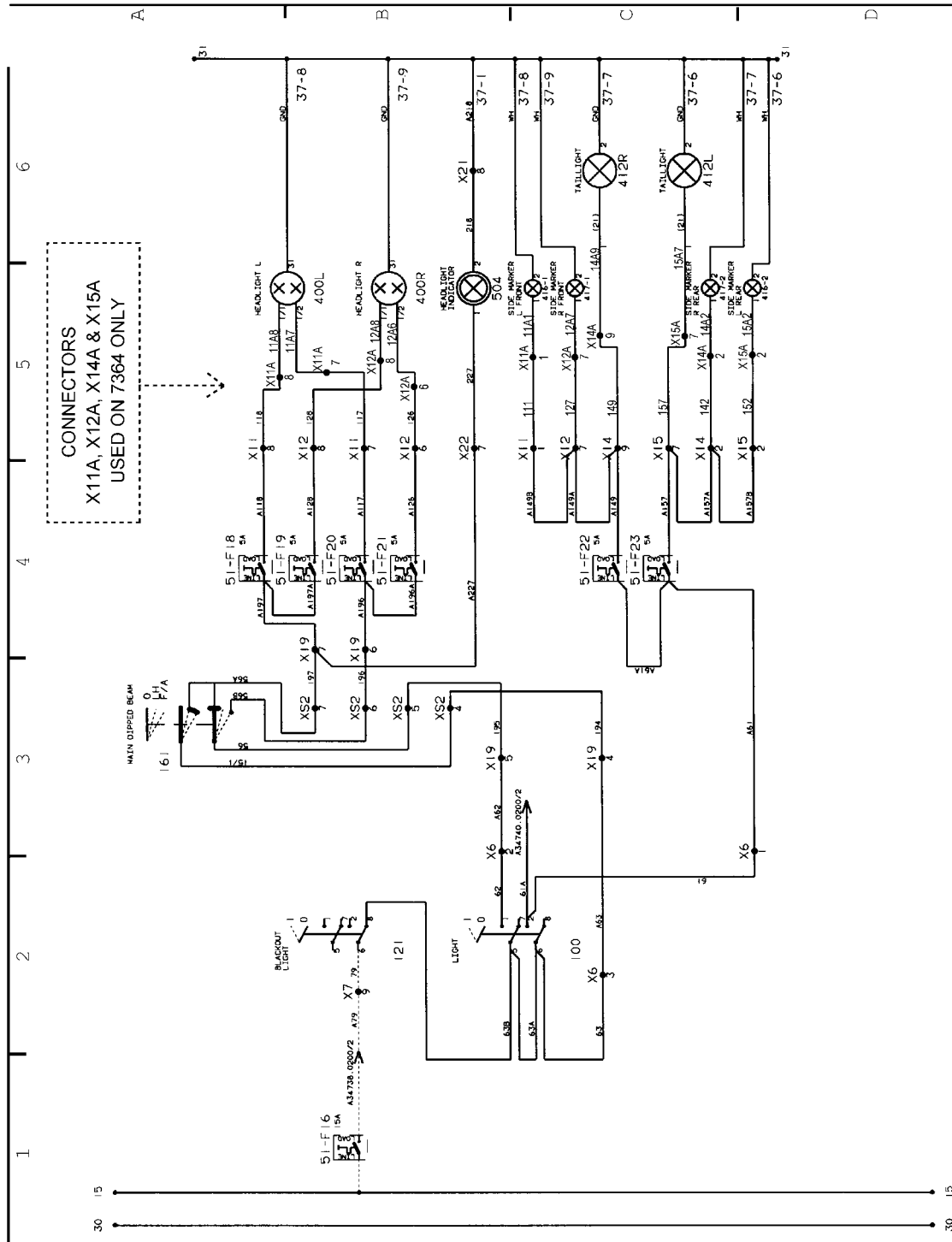


Figure 13. Cab (A34743.0200) Page 1 of 1.



350-1123

Figure 14. Lights (A34744.0200) Page 1 of 5.

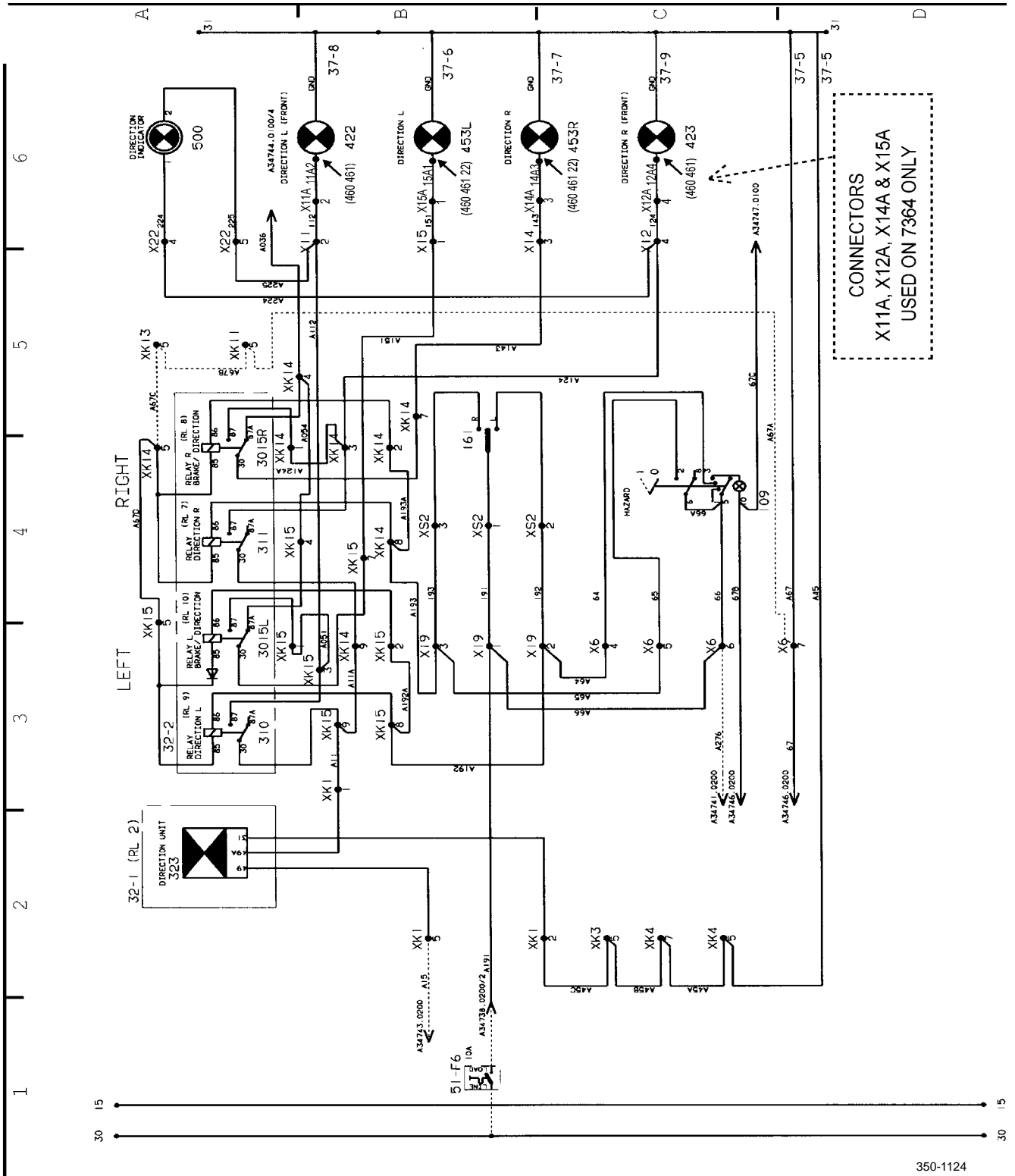


Figure 14. Lights (A34744.0200) Page 2 of 5.

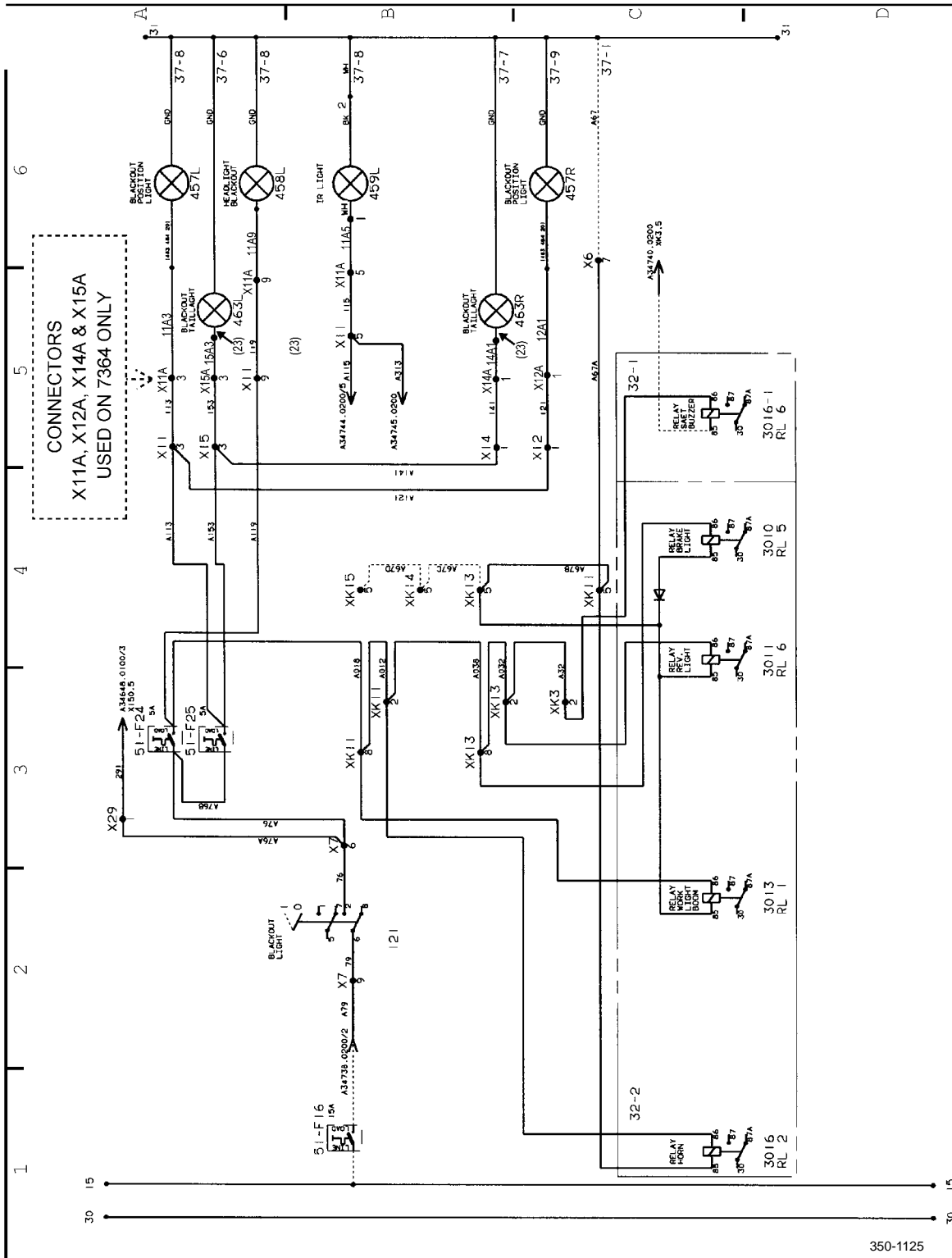


Figure 14. Lights (A3744.0200) Page 3 of 5.

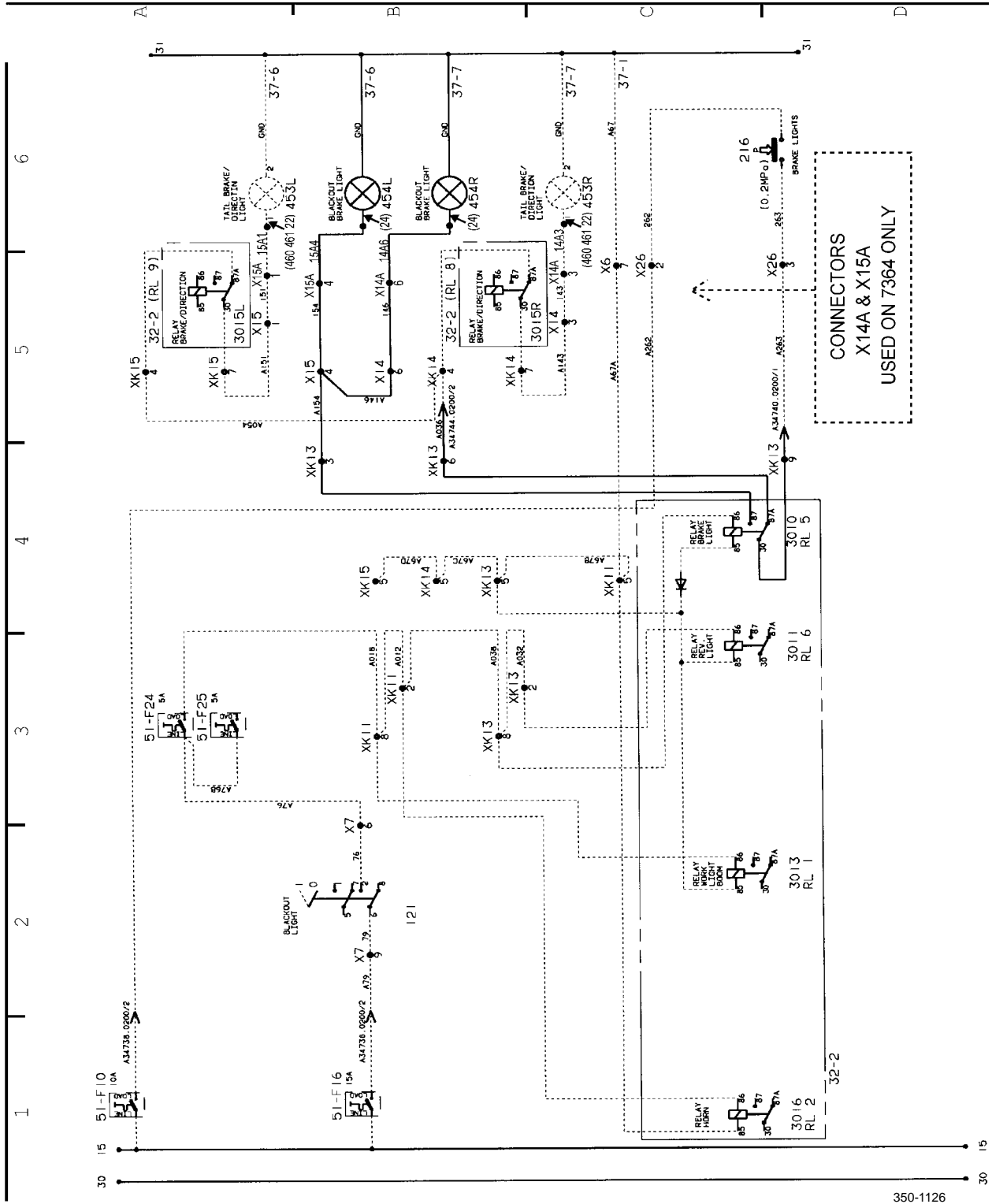
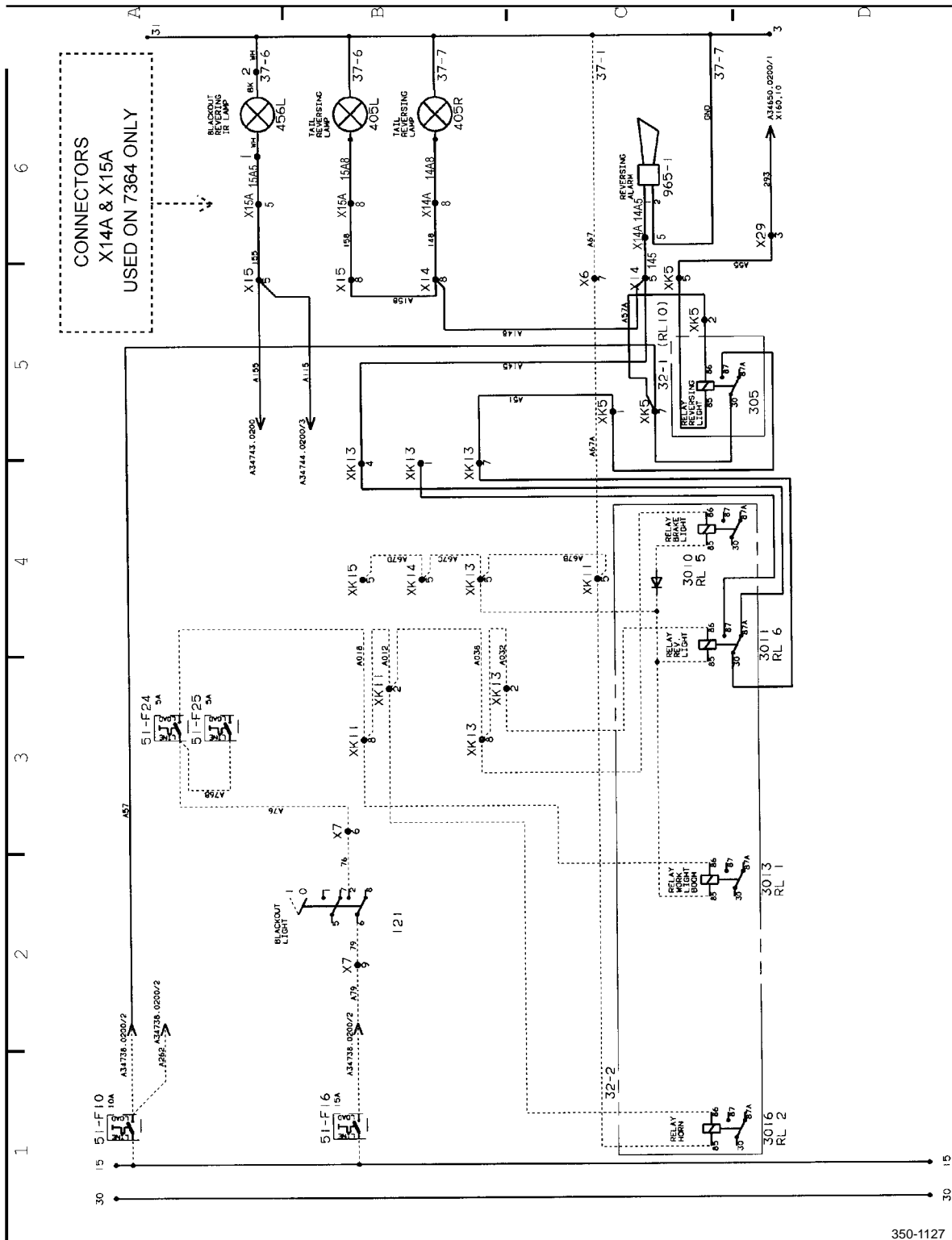


Figure 14. Lights (A34744.0200) Page 4 of 5.



CONNECTORS
X14A & X15A
USED ON 7364 ONLY

Figure 14. Lights (A34744.0200) Page 5 of 5.

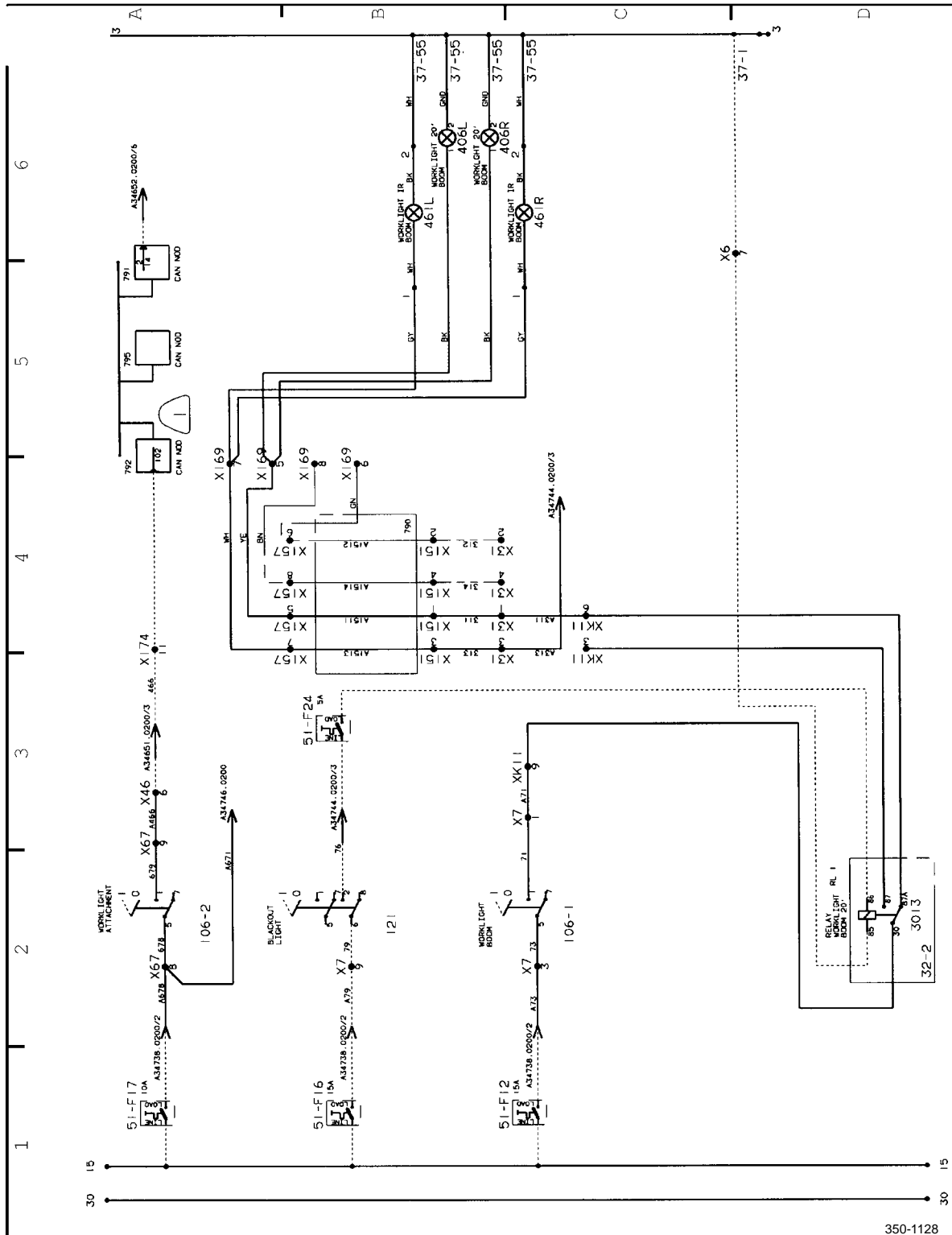


Figure 15. Work Lights (A34745.0200) Page 1 of 1.

350-1128

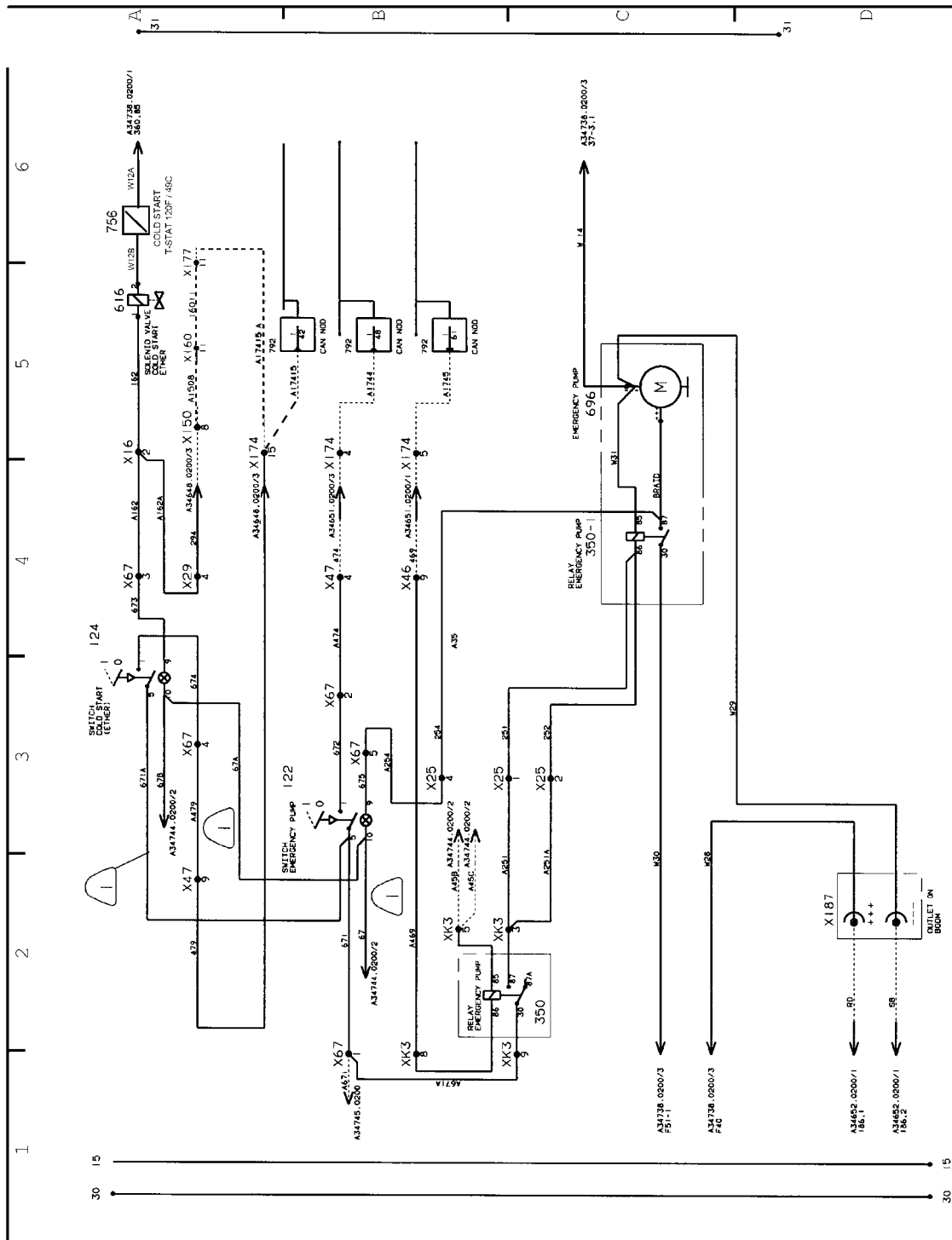
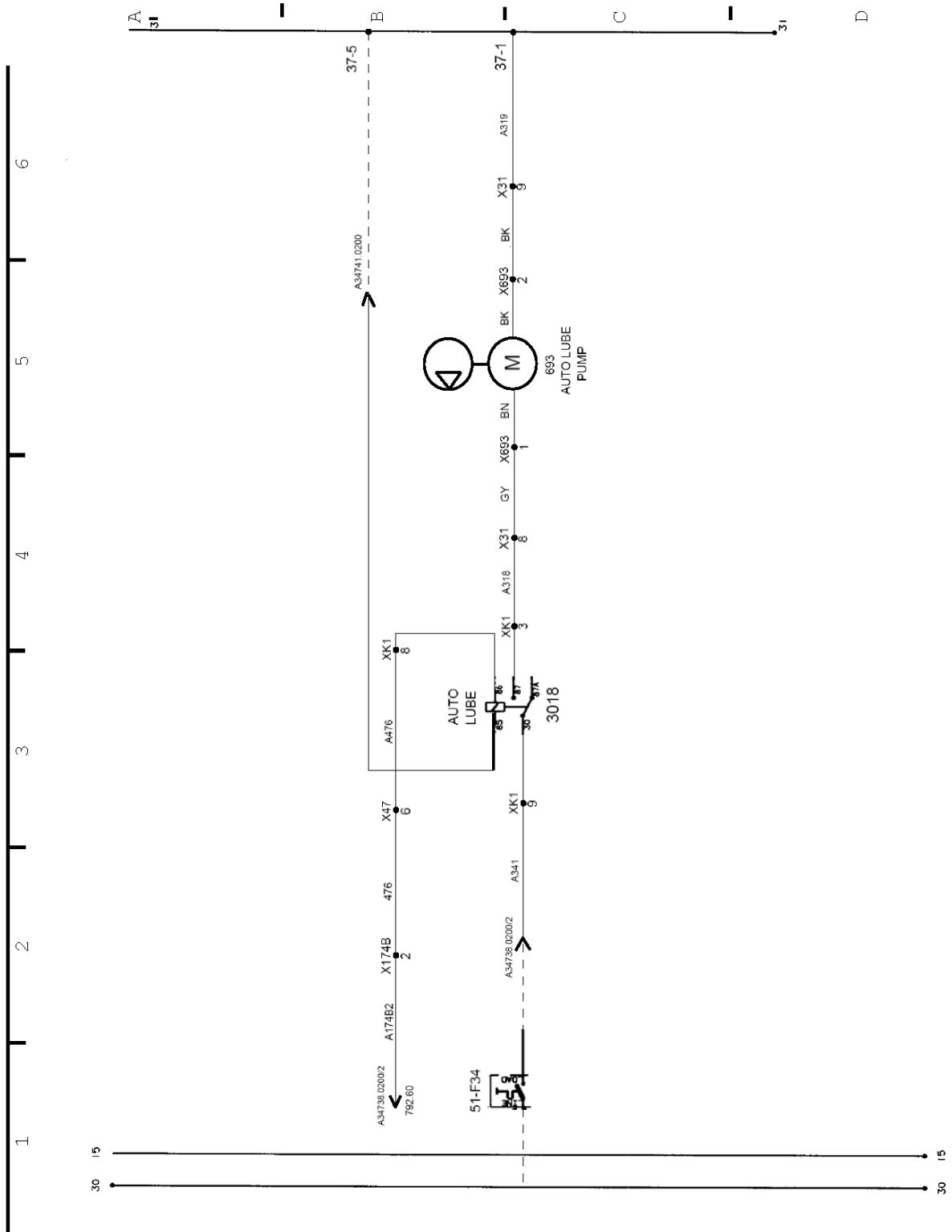


Figure 16. Auxiliary Pump (A3746.0200) Page 1 of 1.



434-40042

Figure 17. Auto Lubrication (A48665.0100) Page 1 of 1.

Fuses		
51-F		
Before Key	F1	25A Condenser 20A - 7364 ONLY
	F2	10A Courtesy Light, Flashing Relay, IR-Light , Ignition Switch
	F3	10A Brake Pressure Sensor, Park-Brake Relay, Seat Buzzer, Inching
	F4	10A Control Unit Engine
	F5	10A Control Unit Engine
	F6	10A Direction Indicator, Wiper Front Return Pulse
After Key	F7	5A Charging Indicator Lamp, Parking Brake Indicator Lamp, Fuel Gage
	F8	5A Gear Shifting
	F9	10A Intermittent Wiper Front, Wiper Front
	F10	10A Brake Light Sensor, Reversing Light, Reversing Alarm
	F11	25A AC Fan, Recirculation 20A - 7364 ONLY
	F12	15A Worklight Boom
	F13	5A Engine , Ignition Switch
	F14	5A Voltage Converter 24V - 12V, Outlet 12V and 24V
	F15	10A Wiper Motor Roof, Wiper Motor Rear, Interval Wiper
	F16	15A Headlights, Blackout Lights, Instrument Lights
	F17	10A Working Lights Attachment, Aux Elec Hydr Pump, Coldstart (Ether)
Before Key	F18	5A Main Headlight Left
	F19	5A Main Headlight Right
	F20	5A Dipped Headlight Left
	F21	5A Dipped Headlight Right
	F22	5A Taillight Right, Side Marker Front
	F23	5A Taillight Left, Side Marker Rear
	F24	5A Blackout Relay, Blackout Left Front
	F25	5A Blackout Right/Left Taillight and Blackout, Position, Light Front
	F26	5A Control Unit Steering Output
	F27	10A Control Unit Gearbox ECU
After Key	F28	10A Control Unit Gearbox ECU
	F29	10A Control Unit Steering SBC, Filter Indication, Water Level, Sensor Cab
	F30	15A Control Unit EI Servo ECS
	F31	5A Display
	F32	5A Control Unit EI Servo ECS
Before Key	F33	5A Water Level , Sensor Cab ; 3998R / 7364
	F34	10A Auto Lubrication ; 7364
F41	10A Control Unit Attachment (Tophandler)	
F42	10A Transmitter	
F43	10A Worklight Attachment (Tophandler)	
F50-1	50A Cab Distribution Box	
F50-2	50A Cab Distribution Box	
F51-1	50A Aux Elec. Hydraulic Pump	
F51-2	50A Aux Elec. Hydraulic Pump	
F40	50A Feeding Attachment (Tophandler)	

Electric Circuit			
Pos	Name	ANT/No	RITN. Number
1	Circuit Current Supply	1-4	A34738.0200
2	Circuit Gear Shifting, Throttle	1	A34739.0200
3	Circuit, Sender Gage	1-2	A34740.0200
4	Wiper	1	A34741.0200
5	Circuit AC & Fan	1	A34742.0200
6	Circuit Cab	1	A34743.0200
7	Circuit, Light, Blackout	1-5	A34744.0200
8	Circuit, Worklight	1	A34745.0200
9	Circuit, Aux Hydr Pump, Coldstart	1	A34746.0200
10	Circuit, ECS Display-CAN-BU	1-3	A34647.0200
11	Circuit, ECS EI Servo	1-5	A34648.0200
12	Circuit ECS Engine	1-2	A34649.0200
13	Circuit, Gearbox	1-4	A34650.0200
14	Circuit, Steering	1-7	A34651.0200
15	Circuit, ECS Attachment	1-6	A34652.0200
16	Circuit, Hydraulic	1-2	A34654.0200
17	Circuit, Autolube	1-1	A48665.0100

	Number	Relay
32-1	3018	Autolube ; 7364
	323	Turn Signal Flasher
	316	Wiper , Front
	330	Starter Interlock
	350	Aux Pump
	3016-1	Seat Buzzer B/O
	RL 7	Reserved
	314	Parking Brake Indicator
	RL 9	Reserved
	305	Reverse Lights / Alarm
32-2	3013	Worklight Boom, STD B/O
	3016	Horn B/O
	RL 3	Reserved
	330-1	Starter Interlock
	3010	Brake Light B/O
	3011	Reversing, B/O
	311	Right Direction
	3015R	Turn Signal - Brake Lgt, Right
	3015L	Turn Signal - Brake Lgt, Left
	310	Left Direction
ELC	321-1	Intermittent Wiper
	321-2	Intermittent Wiper, Rear
	315	Ignition
ENG	360	Starting Solenoid
ELC Attachment	Number	Relay
	3009-1	Emergency Stop
	3009-2	Emergency Stop
	3009-3	Emergency Stop
	3017	Worklight Tophandler
	315-1	Starting Key
350-1	Aux Ele Hydraulic Pump	

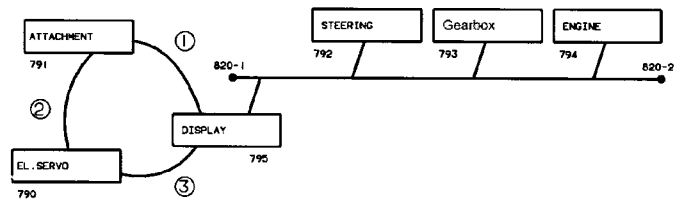
350-1130

Figure 18. Information (A34749.0200) Page 1 of 2.

Number	Socket	No. of Pins
XK1-XK5	Sockets Printed Circuit Board	9
XK11-XK15	Sockets Printed Circuit Board	9
X6	Lamp Switch	9
X7	Lamp Switch	9
X8	Ignition Lock	9
X9	Wiper Switch	9
X10	Gauge, Voltage Converter 21-12V	9
X11	Lights, Left Front	9
X12	Lights, Right Front	9
X13	Horn, Washer, Wiper Rear	9
X14	Lights, Right Rear	9
X15	Lights, Left Front	9
X16	Throttle Pedal	9
X17	Alternator, AC Compressor, Starter	9
X18	Sender, Inching, Brake Pressure R-L	9
X19	Switch, Direction, Main Dipped	9
X20	Switch, Washer, Front Wiper, Horn	9
X21	Indicator Lamp	9
X22	Indicator Lamp	9
X23	Throttle Pedal	9
X24	Wiper, Roof Interior Light	9
X25	Fuel Transmitter, Relay Emergency Pump	9
X26	Seat Buzzer, Transmission, Parking Brake	9
X27	Fan, Wiper Motor, Front	9
X28	Gear Changing	9
X29	EI Servo X150	9
X30	EI Servo X150	9
X31	EI Servo X151	9
X32	Condenser, Temp Out	9
X33	Arctic Kit (Option)	9
X34	Arctic Kit (Option)	9
X46	Control Unit Gearbox X174	9
X47	Control Unit Gearbox X174	9
X67	Emergency Pump, Coldstart, W-Light Boom	9
X69	Rear Fan	9
X150	Distribution Unit	15
X151	Distribution Unit	15
X152	Display	15
X153	Steering Wheel Panel	15
X154	Emergency Stop	15
X155	Joystick Panel	15
X156	Temp Steering/Brake Cooling	15
X157	Boom	15
X158	Valves Boom	15
X159	Transmitter Cylinder	15
X160	Gear Changing	15
X161	CAN-BUS Attachment (Tophandler)	15
X170	Steering Rear Wheel	15
X171	Steering Front Wheel	15
X172	Gearbox	15
X173	Gearbox	15
X174	Distribution Unit	15
X175	Transmitter Cab	15
X176	Steering Force Simulator	15
X177	EI Servo	15
X178	Diagnose ZF	15
X179	CAN-BUS	15
X180	ECU Attachment	15
X181	Transmitter	14
X186-1	Current Supply	1
X186-2	Current Supply	1
X188	Valve Solenoid	14
X189	Valve Solenoid	14
X194	Worklight Attachment (Tophandler)	14
X195	Hydraulic Filter Indication	15
X196	Valve Solenoid Steering	15
X197	Valve Solenoid Steering	15
X198	Filter Indicator, Sensor Cab, Water Level, Temp Hyd, Valve Tilting Tower	15
X199	CAN - J1939	3
X200	Communication PC-ME	9
X201	Communication PC-ME	9

A37314.0200	Install Chassis
A37311.0200	Install Chassis ECS
A37313.0200	Install Cab ECS
A37312.0200	Install Boom ECS
A32685.0400	Install ELC
A36980.0200	Install ELC Attachment
A37401.0200	Install EL Servo
A37727.0200	Install Steering ECS
A38389.0200	Install Engine, TRA

Number	Earth Connections
37-1	Distribution Unit
37-2	Cab Roof
37-3	Frame, Batteries
37-4	Engine
37-5	Computers
37-6	Lights, Left Rear
37-7	Lights, Right Rear
37-8	Lights, Left Rear
37-9	Lights, Right Rear
37-10	Cab Floor AC
37-50-51	Servo
37-52	Steering ECS
37-54-55	Distribution Unit Attachment
37-60	Cab Floor Seat



BLOCK DIAGRAM, CAN-BUS

Figure 18. Information (A34749.0200) Page 2 of 2.

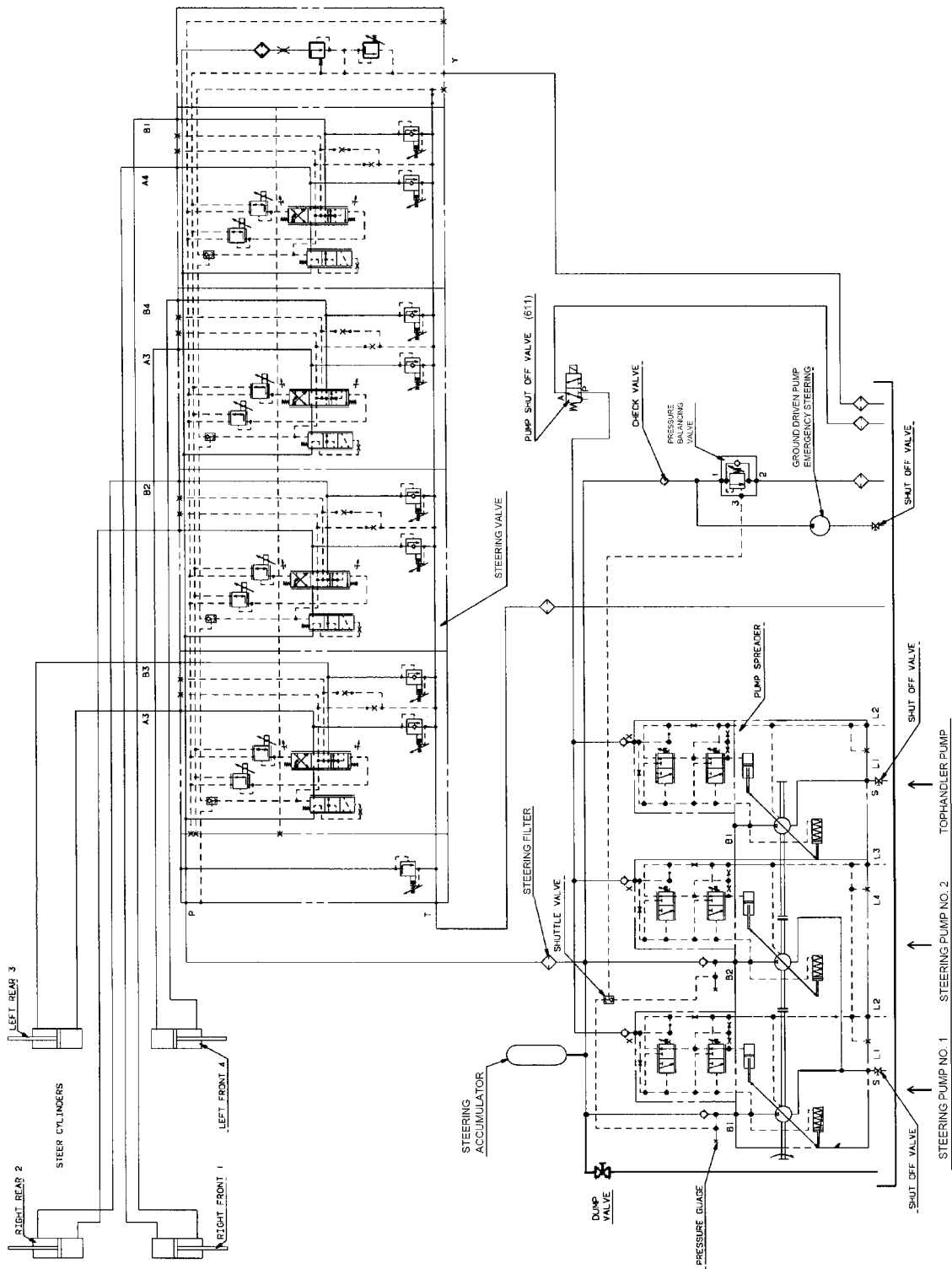


Figure 19. Steering System.

350-1133

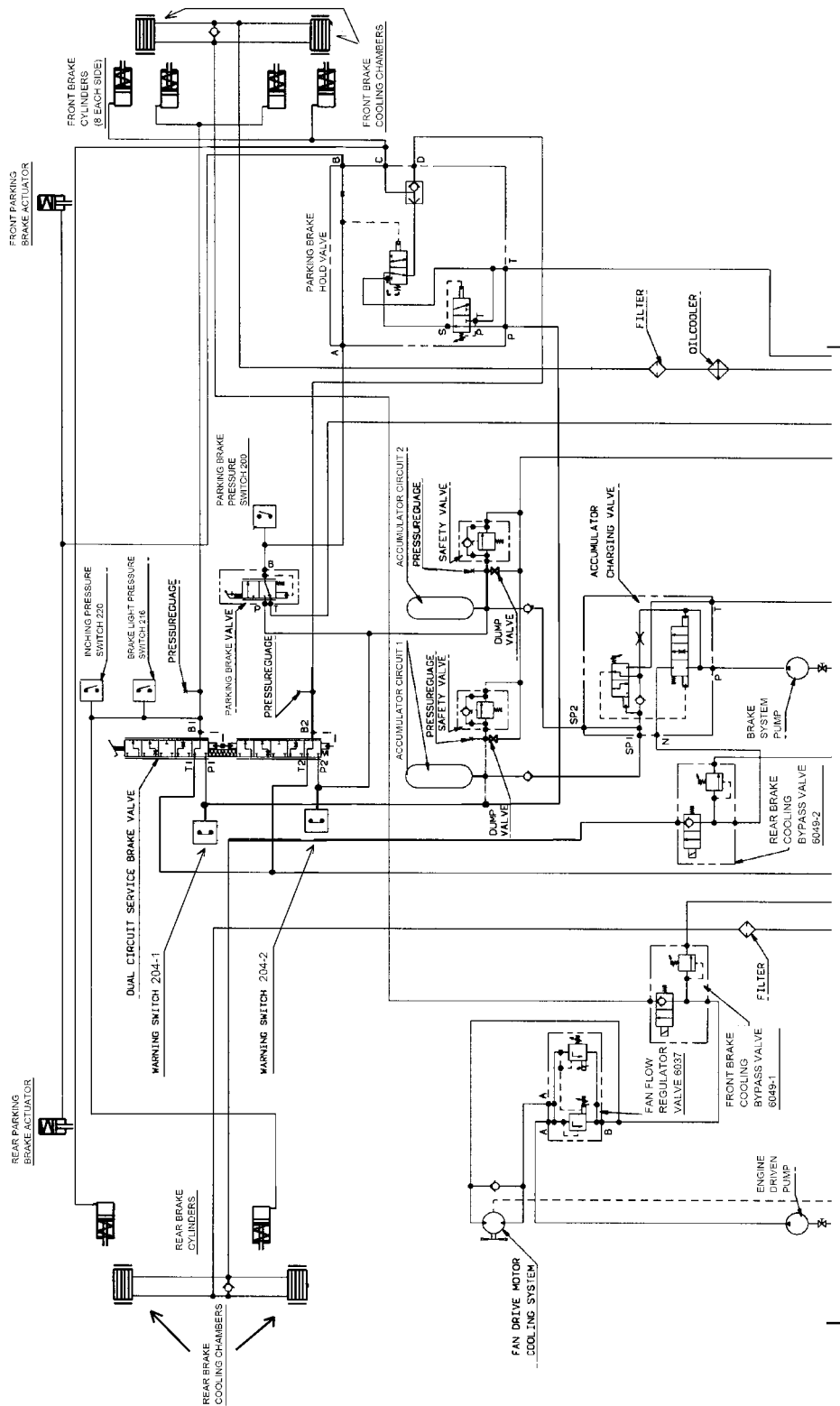
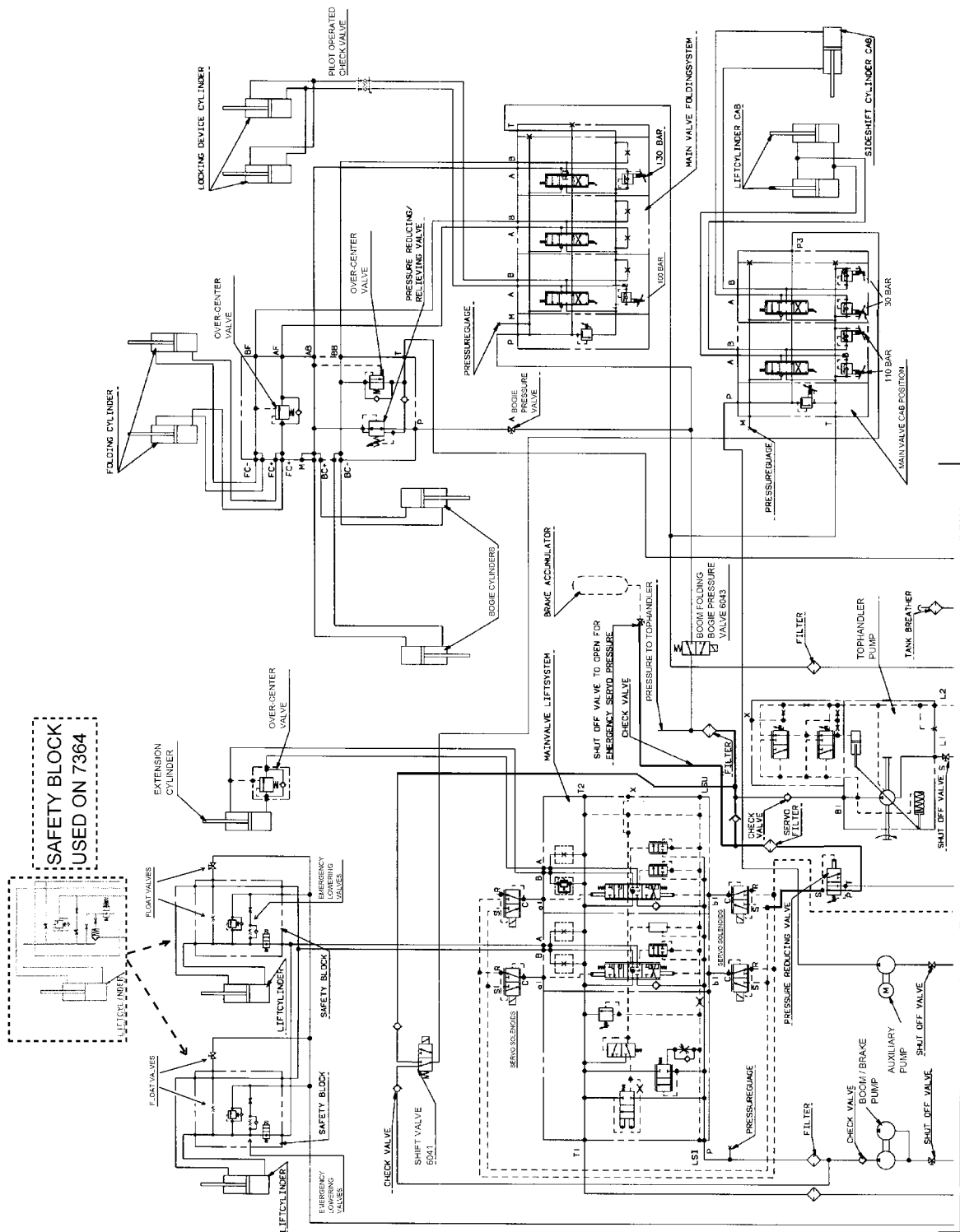


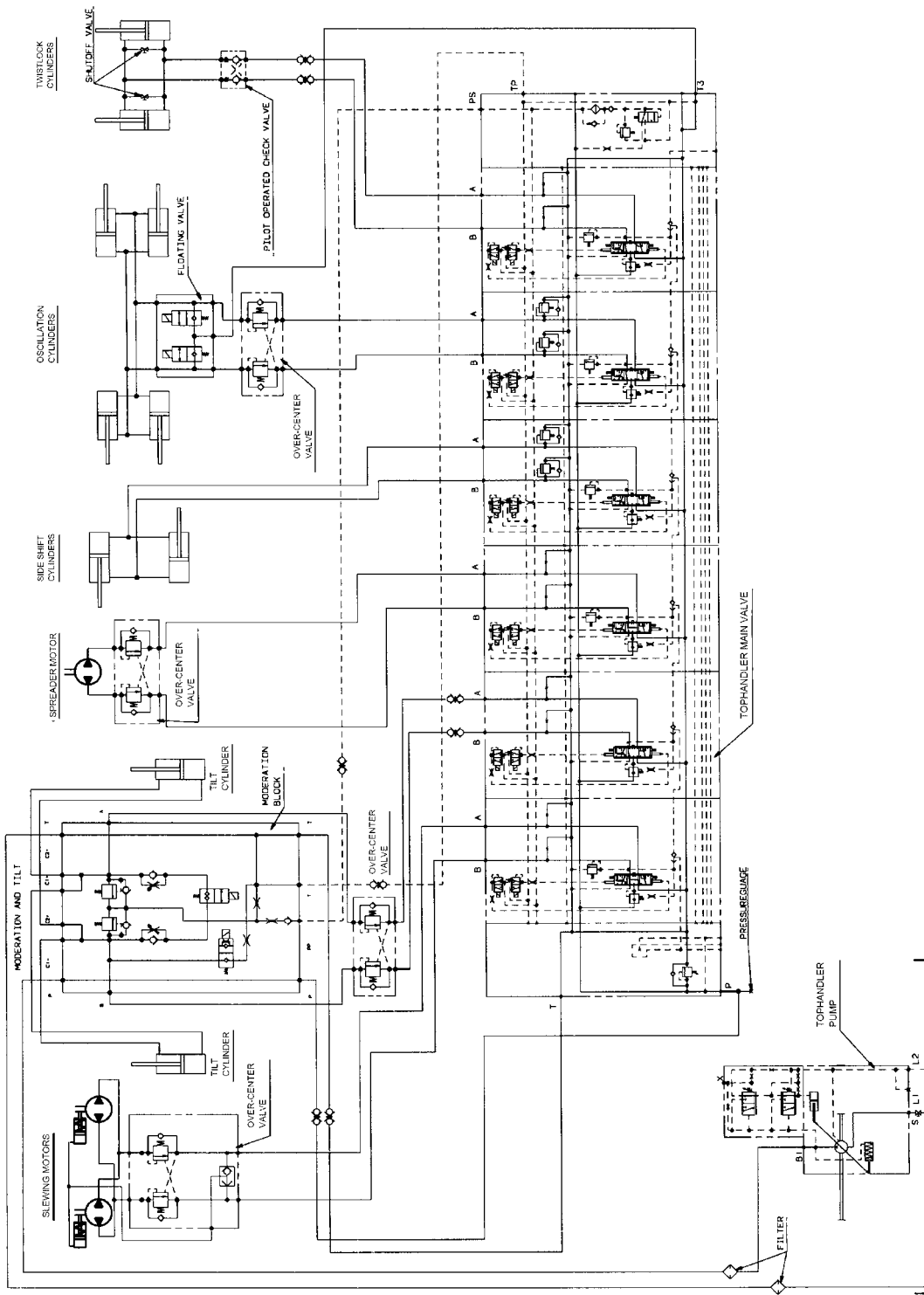
Figure 20. Brake System.

350-1132



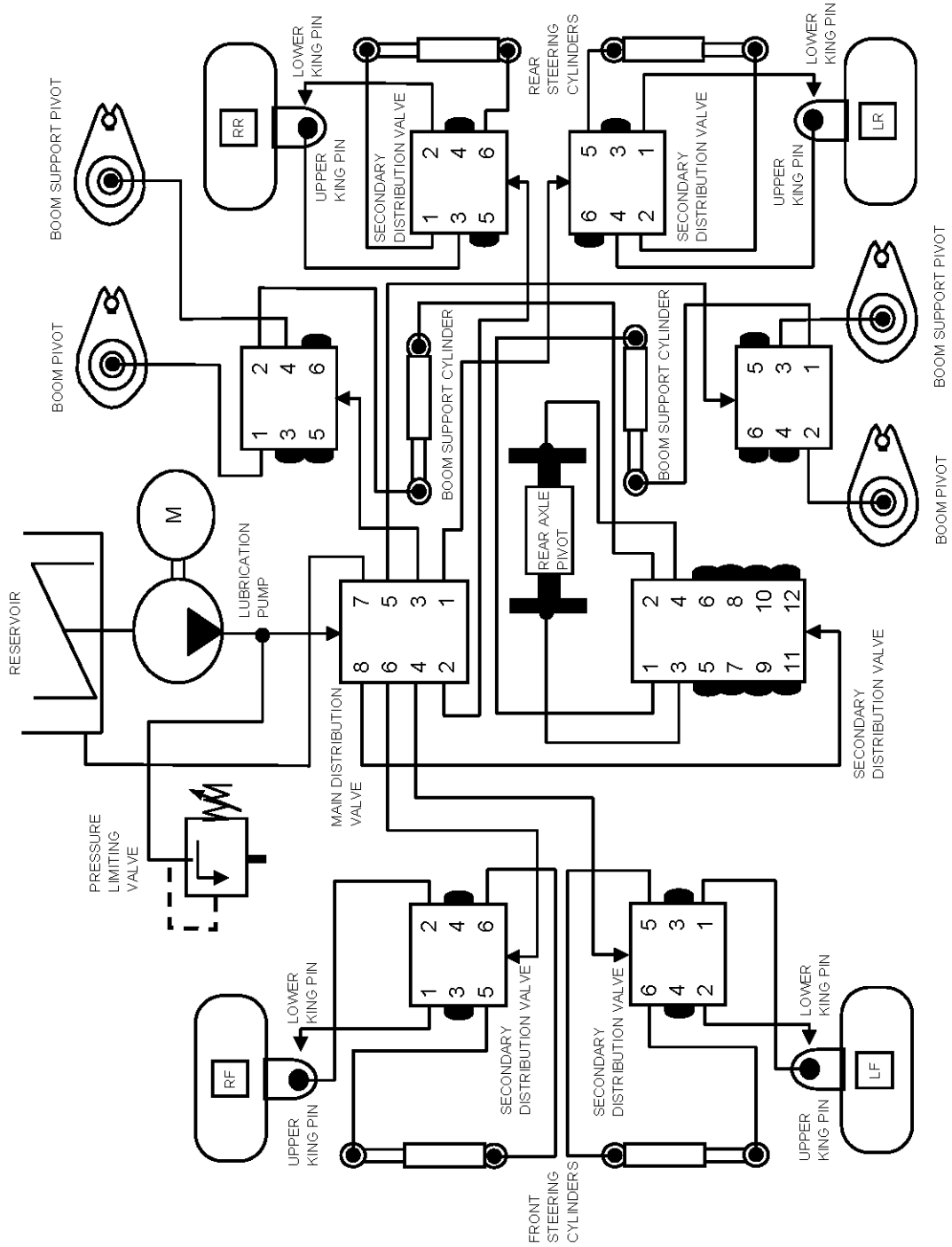
350-1131

Figure 21. Main System.



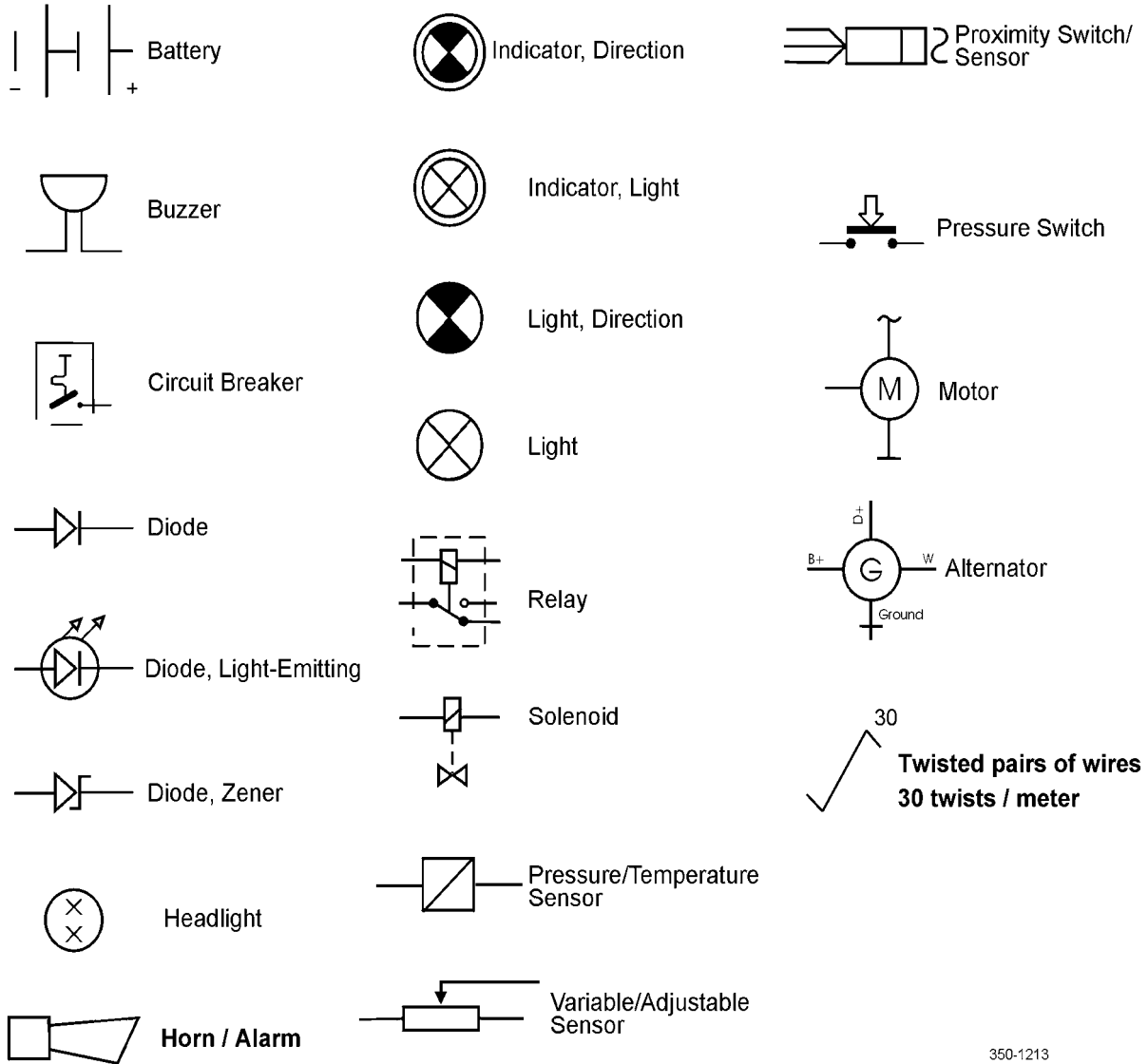
350-1134

Figure 22. Tophandler System.



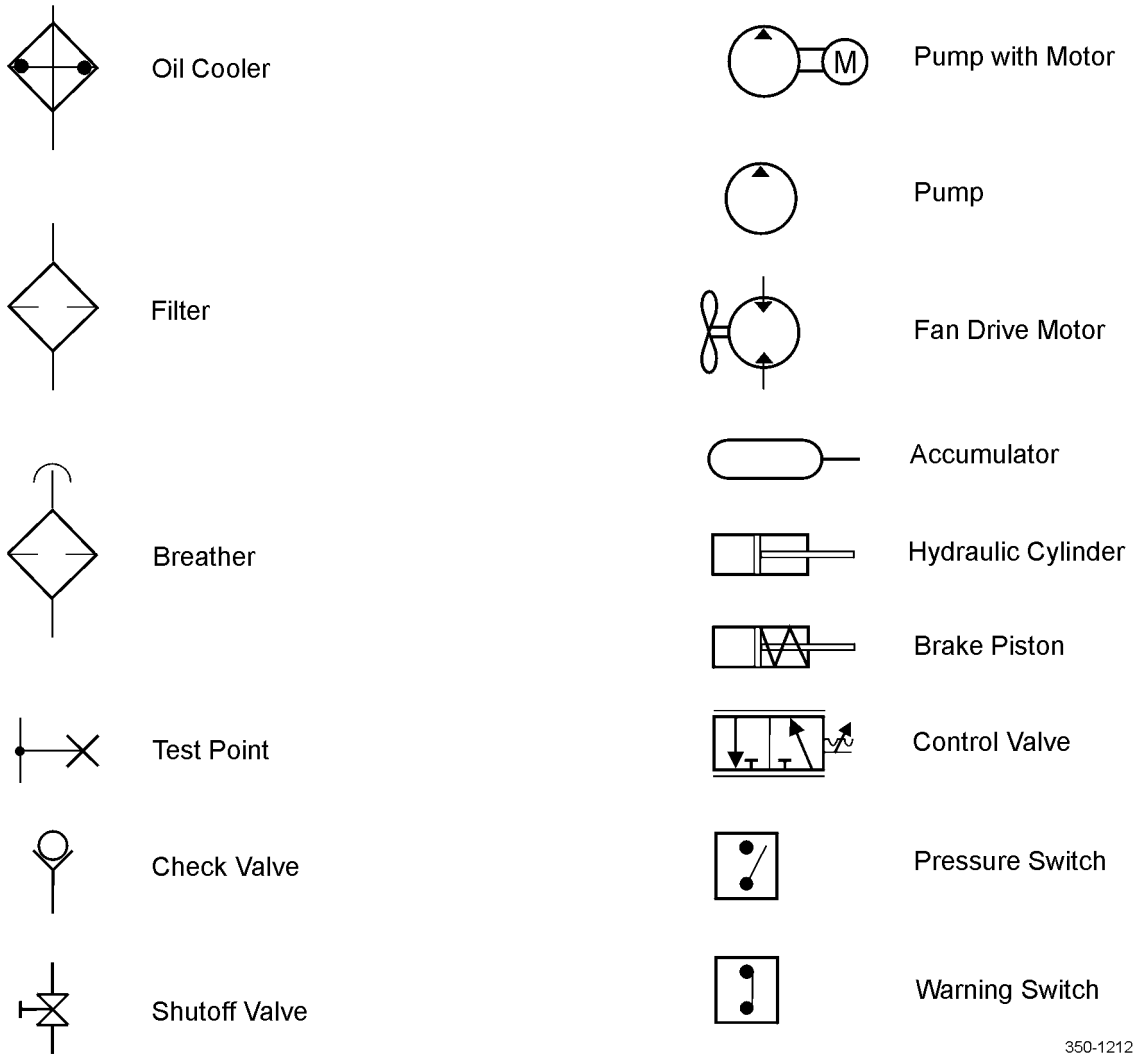
434-40043

Figure 23. Autolube System Tubing Layout.



350-1213

Figure 24. Electrical Symbols.



350-1212

Figure 25. Hydraulic Symbols.

NOTES FOR READING THE KALMAR RT 240 ELECTRICAL DIAGRAMS

Here are several observations and rules for navigating through the Kalmar RT 240 electrical diagrams. Knowing these simple facts about the diagrams should make your understanding of the RT 240 electrical system easier.

RT240 MODEL DESIGNATION

The electrical diagrams include notes and designations for the differences between the original RT 240 model (3998) the RESET model (3998R) and the Version 2 model (7364).

DIAGRAM NUMBERS

Each diagram number begins with a capital “A”, five digits, a decimal point and then 0200; A34647.0200.

The easiest way to identify a diagram is to focus on the last two numbers before the decimal point; A34647.0200

The table of contents also lists each diagram with a figure number.

DIAGRAM PAGES

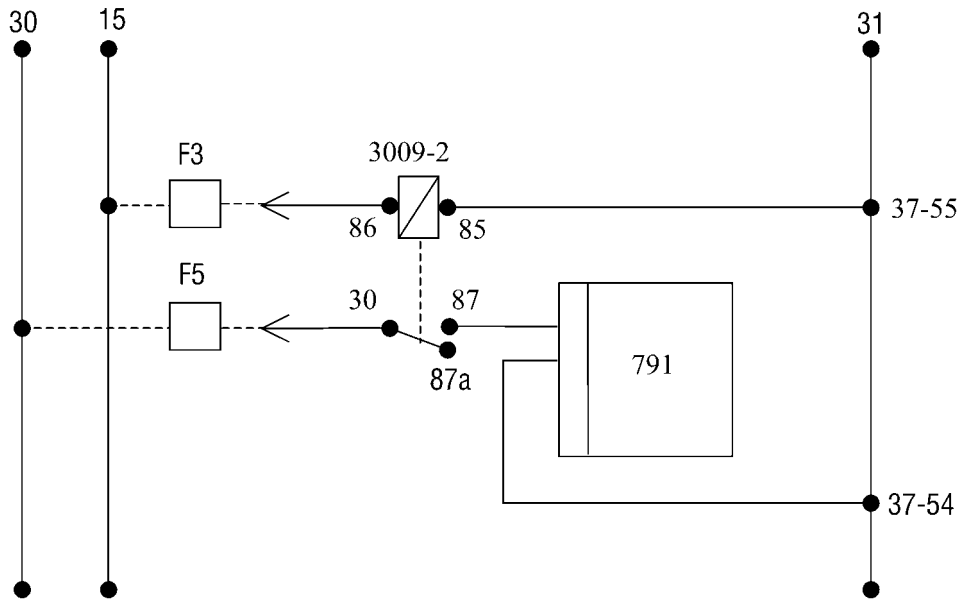
Each diagram consists of one or several pages. Each diagram page has the figure number, title of the diagram and then the diagram number in parentheses. The page number of each multi-page diagram is indicated by: Page 1 of 3, Page 2 of 3, and so on.

Figure 1. ECS Display/CAN-BUS (A34647.200) Page 1 of 3.

Figure 1. ECS Display/CAN-BUS (A34647.0200) Page 2 of 3.

DIAGRAM TYPE

These diagrams are known as “Ladder Schematics”. Most diagrams will have vertical lines on each side of the page. The lines on the left are generally “Positive” battery voltage and the line on the right is generally “Negative” battery ground. All the lines in between are switch and load components. See example below.



434-40044

DIAGRAM ELEMENTS

Vertical line at left (30) = Positive battery voltage from the master switch or when “before key” circuit breakers are energized from the master switch.

Vertical line at left (15) = Positive battery voltage when ignition switch is switched ON and “after key” circuit breakers are energized.

Vertical line at right (31) = Negative battery ground.

F3 and F5 = Circuit breakers.

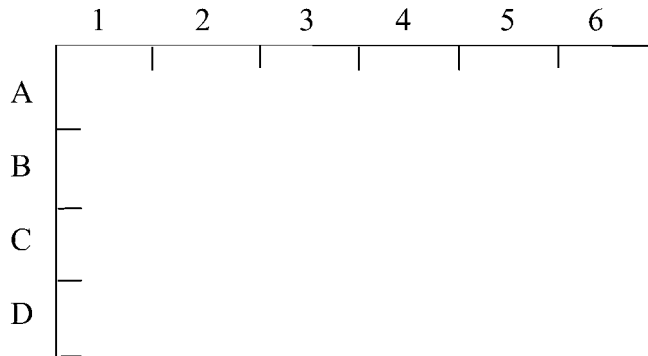
3009-2 = Relay; 86 is positive side of coil, 85 is ground side of coil, 30 to 87a are “normally closed” contacts and 30 to 87 is “normally open” contacts.

791 = Electronic Control Unit (ECU).

37-54 and 37-55 = Ground connections.

DIAGRAM GRID

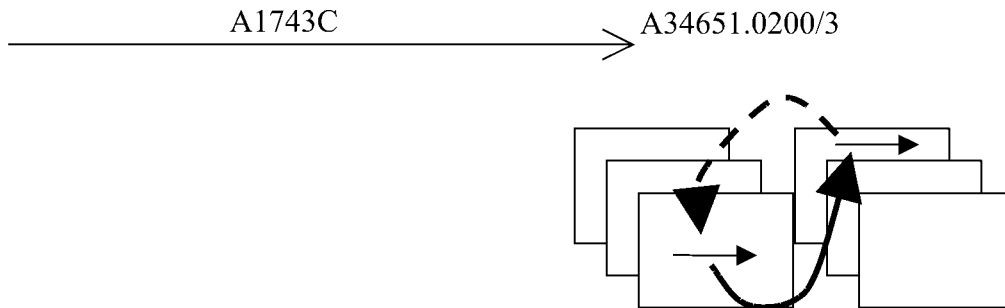
The diagrams have grid rules across the top and right side of the diagram for locating the wires that continue on another page. These grid lines are only used when following a wire from one page to another within the same diagram.



434-40045

WIRE TRACING

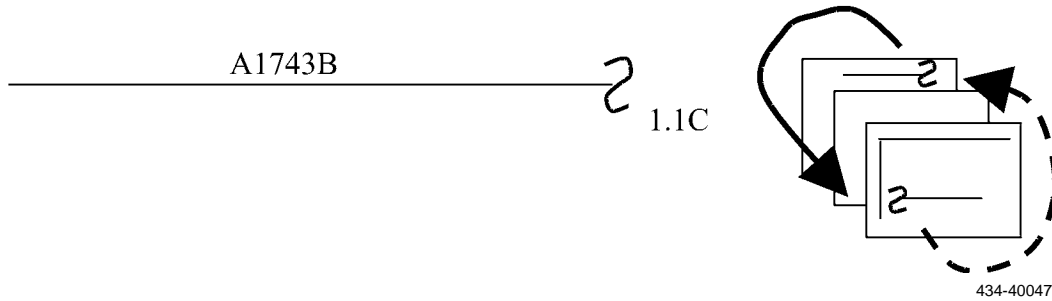
There are two types of wires that will continue off one page and on to another. Below are two examples.



434-40046

WIRE TRACING - CONTINUED

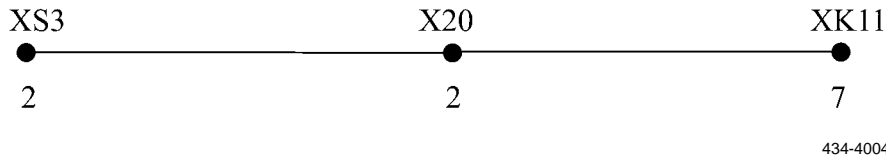
This wire will take you to another diagram. The diagram number at the end of the arrow head indicates which diagram to go to and the “/3” indicates which page of that diagram. The wire is located on the page by wire number. The wire you go to will also reference the diagram and page number you came from.



This wire will take you to another page of the same diagram. The 1 of the 1.1C indicates which page to go to and the 1C references the grid coordinates to locate the wire. Wire number is also used to identify the location.

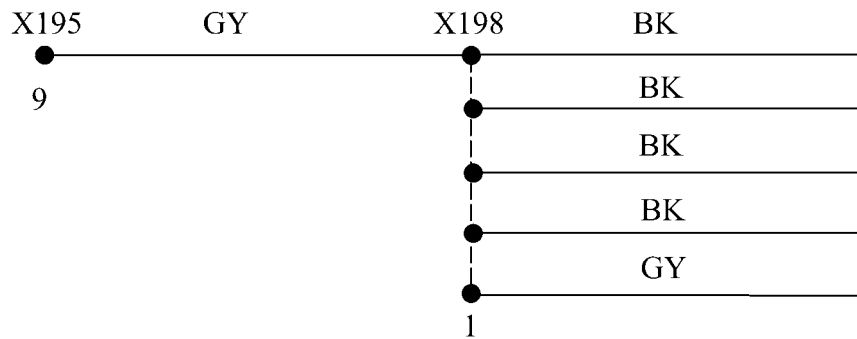
CONNECTORS

Connectors are indicated by a designation “X”, “XK”, or “XS”. A connector can be any type of connecting device such as terminal blocks, 15 pin or 9 pin Amp connector or Deutsch connectors. The “X” connector is the most common. The “XK” connectors are only found on the two relay boards in the breaker panel. The “XS” connectors are found at the transmission and accessory control levers and wiper connections. The number below the dot is the pin number.



MULTIPLE CONNECTIONS

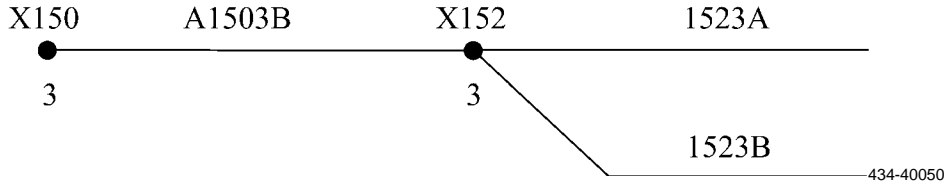
Multiple connections are sometimes made at terminal blocks. The following example shows one of these connections. Jumpers are used to connect several terminal block sections to make one terminal as indicated by the dashed line.



434-40049

MULTIPLE CONNECTIONS - CONTINUED

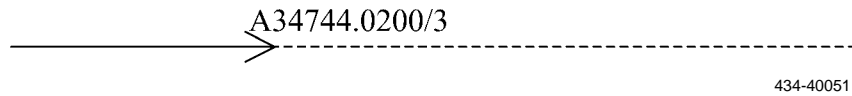
Another multiple connection can be at a single pin.



Sometimes the wire number will reflect the connector and pin number it is going to or coming from. Other wires in the multi-strand cables are designated by colors. The suffix letter in the wire number indicates multiple wires from a single pin or a chain of wires in a connection sequence.

MISCELLANEOUS OBSERVATIONS

Dashed lines that look like wires, and have wire and connector numbers, are wires that can be found on another page of the diagrams in solid drawn lines. These “ghost” lines are there to aid in wire tracing.



Computer connections have several things to take note of:

1. The computer number is indicated at the bottom or top of the computer symbol. The connector number will also be at one of these locations.
2. The pin numbers are indicated along with an arrow, as in the case of the 790, 791, 793, and 795 computers. The arrows show whether it is an input or output or two way flow.
3. Each pin will have a brief label attached to it. The “0V REF” usually designates a ground.

CONNECTOR 1

26 ←	0V REF +10
27 ←	+10V REF
1 →	+24V MAIN POWER
15 →	+24V MAIN POWER
14 →	0V REF MAIN
28 →	0V REF MAIN
2 ↔	CAN-BUSS +LEFT
3 ↔	CAN-BUSS -LEFT

791

434-40052

END OF WORK PACKAGE

CHAPTER 6
SUPPORTING INFORMATION

REFERENCES

0287 00

SCOPE

This work package lists all forms, field manuals, technical bulletins, technical manuals, and other publications referenced in this manual and which apply to Direct and General Support Maintenance of the RTCH-RT 240.

PUBLICATIONS INDEXES

The following indexes should be consulted frequently for latest changes or revisions and for new publications relating to material covered in this technical manual.

- Consolidated Index of Army Publications and Blank Forms DA Pam 25-30
- The Army Maintenance Management System (TAMMS) Users Manual DA Pam 750-8
- U.S. Army Equipment Index of Modification Work Orders DA Pam 750-10

FORMS

Refer to DA Pam 750-8, *The Army Maintenance Management System (TAMMS)* for instructions on the use of maintenance forms.

- Equipment Inspection and Maintenance Worksheet DA Form 5988-E
- Equipment Log Assembly (Records) DA Form 2408
- Maintenance Request Form DA Form 5990-E
- Preventive Maintenance Schedule and Record DA Form 5986-E
- Processing and Deprocessing Record for Shipment, Storage and Issue of Vehicles and Spare Engines DD Form 1397
- Product Quality Deficiency Report SF Form 368
- Recommended Changes to Equipment Technical Publications DA Form 2028-2
- Recommended Changes to Publications and Blank Forms DA Form 2028
- Report of Discrepancy (ROD) SF Form 364
- Request for AOAP DD Form 2026, DA Form 5991-E

FIELD MANUALS

- Basic Cold Weather Manual FM 31-70
- Camouflage FM 5-20-3
- Chemical, Biological, Radiological, and Nuclear Defense FM 21-40
- First Aid FM 4-25.11
- Northern Operations FM 31-71
- Operation and Maintenance of Ordnance Material in Extreme Cold Weather (0°F to -65°F) FM 9-207

TECHNICAL BULLETINS AND SUPPLY BULLETINS

- Color, Marking, and Camouflage Painting of Military Vehicles, Construction Equipment, and Materials Handling Equipment TB 43-0209
- Solder and Soldering TB SIG 222
- Use of Antifreeze Solutions and Cleaning Compounds in Engine Cooling Systems TB 750-651
- Warranty Bulletin for RT 240 RTCH TB 10-3930-675-24

TECHNICAL MANUALS

- Chemical, Biological, Radiological, and Nuclear Defense TM 3-220
- Cooling Systems: Tactical Vehicles TM 750-254
- Inspection, Care, and Maintenance of Antifriction Bearings TM 9-214

REFERENCES - CONTINUED

0287 00

TECHNICAL MANUALS - CONTINUED

Materials Used for Cleaning, Preserving, Abrading and Cementing Ordnance
 Materiel and Related Materials, Including Chemicals TM 9-247

Operator's, Unit, Direct Support and General Maintenance Manual for
 Care, Maintenance, Repair and Inspection of Pneumatic Tires and Inner Tubes TM 9-2610-200-14

Operator's, Organizational, Direct Support, and General Support Maintenance
 Manual for Lead-Acid Storage Batteries TM 9-6140-200-14

Operator's Manual for RT 240 RTCH. TM 10-3930-675-10

Operator's Manual for Welding Theory and Application TM 9-237

Organizational Maintenance Manual for RT 240 RTCH TM 10-3930-675-20

Painting Instruction for Field Use TM 43-0139

Procedures for Destruction of Tank-Automotive Equipment to Prevent Enemy Use. TM 750-244-6

Repair Parts and Special Tools Lists for RT 240 RTCH. TM 9-2320-302-24P

OTHER PUBLICATIONS

Abbreviations and Acronyms ASME Y14.38-1999

Army Medical Department Expendable/Durable Items CTA 8-100

Expendable/Durable Items (Except Medical, Class V Repair Parts, and Heraldic Items) CTA 50-970

END OF WORK PACKAGE

THE ARMY MAINTENANCE SYSTEM MAC

1. This introduction provides a general explanation of all maintenance and repair functions authorized at the various maintenance levels under the standard Army Maintenance System concept.
2. The MAC immediately following the introduction designates overall authority and responsibility for the performance of maintenance functions on the identified end item or component. The application of the maintenance functions to the end item or component shall be consistent with the capacities and capabilities of the designated maintenance levels, which are shown in the MAC (WP 0289 00) in column (4) as:
 - Unit - includes two subcolumns, C (Operator/Crew) and O (Organizational) Maintenance
 - Direct Support - includes an F subcolumn
 - General Support - includes an H subcolumn
 - Depot - includes a D subcolumn
3. The tools and test equipment requirements (immediately following the MAC) list the tools and test equipment (both special tools and common tool sets) required for each maintenance function as referenced from the MAC.
4. The remarks (immediately following the tools and test equipment requirements) contain supplemental instructions and explanatory notes for a particular maintenance function.

MAINTENANCE FUNCTIONS

Maintenance functions are limited to and defined as follows:

1. **Inspect.** To determine the serviceability of an item by comparing its physical, mechanical, and/or electrical characteristics with established standards through examination (e.g., by sight, sound, or feel).
2. **Test.** To verify serviceability by measuring the mechanical, pneumatic, hydraulic, or electrical characteristics of an item and comparing those characteristics with prescribed standards on a scheduled basis, i.e., load testing of lift devices and hydrostatic testing of pressure hoses.
3. **Service.** Operations required periodically to keep an item in proper operating condition; e.g., to clean (includes decontaminate, when required), to preserve, to drain, to paint, or to replenish fuel, lubricants, chemical fluids, or gases.
4. **Adjust.** To maintain or regulate, within prescribed limits, by bringing into proper position, or by setting the operating characteristics to specified parameters.
5. **Align.** To adjust specified variable elements of an item to bring about optimum or desired performance.
6. **Calibrate.** To determine and cause corrections to be made or to be adjusted on instruments of test, measuring, and diagnostic equipment used in precision measurement. Consists of comparisons of two instruments, one of which is a certified standard of known accuracy, to detect and adjust any discrepancy in the accuracy of the instrument being compared.
7. **Remove/Install.** To remove and install the same item when required to perform service or other maintenance functions. Install may be the act of emplacing, seating, or fixing into position a spare, repair part, or module (component or assembly) in a manner to allow the proper functioning of an equipment or system.
8. **Replace.** To remove an unserviceable item and install a serviceable counterpart in its place. "Replace" is authorized by the MAC and assigned maintenance level is shown as the third position code of the Source, Maintenance and Recoverability (SMR) code.
9. **Repair.** The application of maintenance services, including fault location/troubleshooting, removal/installation, disassembly/assembly procedures, and maintenance actions to identify troubles and restore serviceability to an item by correcting specific damage, fault, malfunction, or failure in a part, subassembly, module (component or assembly), end item, or system.

MAINTENANCE FUNCTIONS - CONTINUED

NOTE

The following definitions are applicable to the “repair” maintenance function:

- Services - Inspect, test, service, adjust, align, calibrate, and/or replace.
 - Fault location/troubleshooting - The process of investigating and detecting the cause of equipment malfunctioning; the act of isolating a fault within a system or Unit Under Test (UUT).
 - Disassembly/assembly - The step-by-step breakdown (taking apart) of a spare/functional group coded item and to the level of its least component, that is assigned an SMR code for the level of maintenance under consideration (i.e., identified as maintenance significant).
 - Actions - Welding, grinding, riveting, straightening, facing, machining, and/or resurfacing.
10. **Overhaul.** That maintenance effort (service/action) prescribed to restore an item to a completely serviceable/operational condition as required by maintenance standards in appropriate technical publications. Overhaul is normally the highest degree of maintenance performed by the Army. Overhaul does not normally return an item to like new condition.
 11. **Rebuild.** Consists of those services/actions necessary for the restoration of unserviceable equipment to a like new condition in accordance with original manufacturing standards. Rebuild is the highest degree of materiel maintenance applied to Army equipment. The rebuild operation includes the act of returning to zero those age measurements (hours/miles, etc.) considered in classifying Army equipment/components.

EXPLANATION OF COLUMNS IN THE MAC, TABLE 1

1. **Column (1) - Group Number.** Column (1) lists FGC numbers, the purpose of which is to identify maintenance significant components, assemblies, subassemblies, and modules with the Next Higher Assembly (NHA).
2. **Column (2) - Component/Assembly.** Column (2) contains the item names of components, assemblies, subassemblies, and modules for which maintenance is authorized.
3. **Column (3) - Maintenance Function.** Column (3) lists the functions to be performed on the item listed in Column (2). (For a detailed explanation of these functions refer to “Maintenance Functions” outlined above).
4. **Column (4) - Maintenance Level.** Column (4) specifies each level of maintenance authorized to perform each function listed in column (3), by indicating work time required (expressed as manhours in whole hours or decimals) in the appropriate subcolumn. This work time figure represents the active time required to perform that maintenance function at the indicated level of maintenance. If the number or complexity of the tasks within the listed maintenance function varies at different maintenance levels, appropriate work time figures are to be shown for each level. The work time figure represents the average time required to restore an item (assembly, subassembly, component, module, end item, or system) to a serviceable condition under typical field operating conditions. This time includes preparation time (including any necessary disassembly/assembly time), troubleshooting/fault location time, and quality assurance time in addition to the time required to perform the specific tasks identified for the maintenance functions authorized in the MAC. The symbol designations for the various maintenance levels are as follows:

- C Operator or Crew Maintenance
- O Organizational Maintenance
- F Direct Support Maintenance
- L Specialized Repair Activity (SRA)
- H General Support Maintenance
- D Depot Maintenance

EXPLANATION OF COLUMNS IN THE MAC, TABLE 1 - CONTINUED**NOTE**

The "L" maintenance level is not included in column (4) of the MAC. Functions to this level of maintenance are identified by a work time figure in the "H" column of column (4), and an associated reference code is used in the REMARKS CODE column (6). This code is keyed to the remarks and the SRA complete repair application is explained there.

5. **Column (5) - Tools and Equipment Reference Code.** Column (5) specifies, by code, those common tool sets (not individual tools), common Test, Measurement and Diagnostic Equipment (TMDE), and special tools, special TMDE, and special support equipment required to perform the designated function. Codes are keyed to the entries in the tools and test equipment table.
6. **Column (6) - Remarks Code.** When applicable, this column contains a letter code, in alphabetical order, which is keyed to the remarks table entries (Table 3).

EXPLANATION OF COLUMNS IN THE TOOLS AND TEST EQUIPMENT REQUIREMENTS, TABLE 2

1. **Column (1) - Tool or Test Equipment Reference Code.** The tool and test equipment reference code correlates with a code used in column (5) of the MAC.
2. **Column (2) - Maintenance Level.** The lowest level of maintenance authorized to use the tool or test equipment.
3. **Column (3) - Nomenclature.** Name or identification of the tool or test equipment.
4. **Column (4) - National Stock Number (NSN).** The NSN of the tool or test equipment.
5. **Column (5) - Tool Number.** The manufacturer's part number, model number, or type number.

EXPLANATION OF COLUMNS IN THE REMARKS, TABLE 3

1. **Column (1) - Remarks Code.** The code recorded in column (6) of the MAC.
2. **Column (2) - Remarks.** This column lists information pertinent to the maintenance function being performed as indicated in the MAC.

END OF WORK PACKAGE

Table 1. MAC for the RT 240 RTCH.

(1) GROUP NUMBER	(2) COMPONENT/ ASSEMBLY	(3) MAINTENANCE FUNCTION	(4) MAINTENANCE LEVEL					(5) TOOLS AND EQUIPMENT REF CODE	(6) REMARKS CODE
			FIELD		SUSTAINMENT				
			UNIT		DS	GS	DEPOT		
			C	O	F	H	D		
01	ENGINE								
0100	Engine Assembly	Inspect Test Service Replace	0.5	1.5 2.0	2.0 36.0			107,128 37,106,107, 117,128	A
		Repair		4.0	4.0	95.5		78,80,106,107, 108,116,117, 128	
	Engine Mounts	Inspect Replace		1.1		12.0		106,128	
	Lifting Bracket	Replace				1.0		106,128	
0101	Crankcase, Cylinder Block, and Head								
	Cylinder Block	Replace Repair					4.0 30.0	106,107,128 28,29,30, 35,37,41, 42,51,60, 71,80,94, 106,107,116, 117,128	
	Cylinder Head Assembly	Inspect Replace Repair			0.5 2.0			10,38,107, 128,131 18,23,32, 34,36,43, 57,59,63, 68,97,101, 108,125,128	
							8.0		
0102	Crankshaft Assembly								
	Crankshaft	Replace					8.0	58,80,91,95, 106,107,109, 116,128	
		Repair			2.0	16.0		106,107,128	
	Vibration Damper	Replace			2.0			7,58,77 107,128	

MAINTENANCE ALLOCATION CHART (MAC) - CONTINUED

0289 00

Table 1. MAC for the RT 240 RTCH - Continued.

(1) GROUP NUMBER	(2) COMPONENT/ ASSEMBLY	(3) MAINTENANCE FUNCTION	(4) MAINTENANCE LEVEL				(5) TOOLS AND EQUIPMENT REF CODE	(6) REMARKS CODE		
			FIELD		SUSTAINMENT					
			UNIT		DS	GS			DEPOT	
			C	O	F	H			D	
01	ENGINE - Continued									
0103	Flywheel Assembly									
	Flywheel	Replace			2.0			6,7,58,77, 107,109,128		
	Flywheel Housing	Replace			4.0			4,7,40,77,106, 108,109,128		
	Main Seals	Replace			4.0			107,108,128		
0104	Piston and Connecting Rod Assemblies									
	Pistons, Pins, and Rings	Replace				35.0		18,22,33,79, 80,106,107, 116,128	D	
	Connecting Rods and Bearings	Replace				35.0		18,22,33,79, 80,106,107, 116,128	D	
0105	Valves, Camshaft, and Timing System									
	Rocker Arm Assemblies	Inspect Replace			1.0 4.0			128 106,107,108, 128		
		Repair			1.5			106,128		
	Rocker Arm Cover	Replace		1.0				108,128		
	Gear Housing	Inspect				1.0		8,78,88,106, 107,128	D	
		Replace				3.0		8,78,88,106, 107,128	D	
	Camshaft Assembly	Inspect Replace				1.0 4.0		128 52,58,87, 106,107,128	D D	
	Camshaft Drive Gear	Inspect Replace				0.5 2.0		128 52,58,87, 106,107,128 64,106,128	D D	
	Cam Follower	Inspect Replace				1.0 3.0		64,106,128 64,106,128	D D	

MAINTENANCE ALLOCATION CHART (MAC) - CONTINUED

0289 00

Table 1. MAC for the RT 240 RTCH - Continued.

(1) GROUP NUMBER	(2) COMPONENT/ ASSEMBLY	(3) MAINTENANCE FUNCTION	(4) MAINTENANCE LEVEL					(5) TOOLS AND EQUIPMENT REF CODE	(6) REMARKS CODE	
			FIELD		SUSTAINMENT					
			UNIT		DS	GS	DEPOT			
			C	O	F	H	D			
01	ENGINE - Continued									
0106	Engine Lubrication System									
	Oil Pan	Inspect Replace		0.7						
					4.0			106,107,128		
	Oil Filter	Replace		0.5				107,128,137		
	Oil Filter Head	Replace			2.0			106,107,120, 128		
	Oil Pump Assembly	Replace				4.0		58,106,107, 128		
	Oil Hoses, Tubes, and Fittings	Replace		2.0				128		
	Oil Sampling Valve	Replace		0.5				128		
0108	Manifolds									
	Exhaust Manifold	Replace			3.0			78,107,128		
	Intake Manifold	Replace			3.0			107,128		
0109	Accessory Drive									
	Gear Housing Cover	Replace			3.0			107,108,128		
	Idler/Drive Gears/ Pulleys/Housing	Replace			4.0	4.0		16,31,58, 62,86,106,107, 128		
03	FUEL SYSTEM									
0301	Fuel Injector									
	Injector	Adjust			2.0			2,3,106,107, 128,139		
		Replace			1.5			85,107,128		
0302	Fuel Pumps									
	Fuel Pump	Replace Repair			4.0			107,128		
				1.0		4.0				
	Hoses, Lines, and Fittings	Inspect Replace		0.5 2.0				128		
	Fuel Solenoid Shutoff Valve	Replace		2.5				108,128		

MAINTENANCE ALLOCATION CHART (MAC) - CONTINUED

0289 00

Table 1. MAC for the RT 240 RTCH - Continued.

(1) GROUP NUMBER	(2) COMPONENT/ ASSEMBLY	(3) MAINTENANCE FUNCTION	(4) MAINTENANCE LEVEL				(5) TOOLS AND EQUIPMENT REF CODE	(6) REMARKS CODE	
			FIELD		SUSTAINMENT				
			UNIT		DS	GS			DEPOT
			C	O	F	H			D
03	FUEL SYSTEM - Continued								
0304	Air Cleaner								
	Air Cleaner Assembly and Element	Inspect Service Replace Repair	0.3 0.5		1.0 0.5			128 128	
	Air Intake Hose and Tube Assembly	Replace		1.0				128	
0305	Turbocharger	Inspect Replace			1.0 2.0			128 39,107,128	
0306	Fuel Tank	Inspect Replace		1.0	8.0			108 112,128	
0309	Fuel Filter/Water Separator	Service Replace	0.5					128,137	
0311	Engine Starting Aid	Service Replace Repair		0.4 1.5 0.5				128 128 128	
0312	Throttle Position Sensor (Accelerator Pedal)	Replace		1.5				128	
04	EXHAUST SYSTEM								
0401	Muffler	Inspect Replace		0.5 3.0				128	
	Exhaust Pipe	Inspect Replace		0.5 3.0				128	
05	COOLING SYSTEM								
0501	Radiator								
	Radiator Assembly	Inspect Service Replace Repair	0.5	1.0 1.0	8.0			128 128	
	Expansion Tank	Service Replace	0.5		2.0	8.0		107,128	
0503	Thermostat	Replace		1.5				107,128	
	Hoses	Replace		1.5				128	

MAINTENANCE ALLOCATION CHART (MAC) - CONTINUED

0289 00

Table 1. MAC for the RT 240 RTCH - Continued.

(1) GROUP NUMBER	(2) COMPONENT/ ASSEMBLY	(3) MAINTENANCE FUNCTION	(4) MAINTENANCE LEVEL					(5) TOOLS AND EQUIPMENT REF CODE	(6) REMARKS CODE	
			FIELD		SUSTAINMENT					
			UNIT		DS	GS	DEPOT			
			C	O	F	H	D			
05	COOLING SYSTEM - Continued									
0504	Water Pump	Replace			3.0			98,99,104, 107,128		
0505	Fan Motor	Replace			3.0			128		
0508	Coolant Filter	Replace		0.7				128		
06	ELECTRICAL SYSTEM									
0601	Generator/Alternator									
	Generator/Alternator Assembly	Test Replace		0.7 1.5				107 107,128		
	Drive Belt	Inspect Adjust Replace	0.7	1.0 1.5				9,107,128 107,128		
0603	Starter									
	Starter Assembly	Test Replace Repair		1.0 1.7		6.0		107 107,128		
0607	Instrument Panel									
	Instrument Panel Switches, Gages, and Indicators Lights	Inspect Replace	0.5	1.0				103,107,128		
	Fuse, Relay, and Circuit Breaker	Replace		1.5				128		
	Proximity Switches	Adjust Replace		0.8 1.5				128 103,107,128		
	Transmission Shift Control Lever	Inspect Replace	0.5	2.0						
0608	Miscellaneous Electrical Components									
	Cables	Replace		1.0				56,128		
	Distribution Box	Replace Repair		1.0 1.5	3.0			103,128 128		
	Temperature and Pressure Sensors/ Switches	Test Replace		0.7 1.5				108 128		

MAINTENANCE ALLOCATION CHART (MAC) - CONTINUED

0289 00

Table 1. MAC for the RT 240 RTCH - Continued.

(1) GROUP NUMBER	(2) COMPONENT/ ASSEMBLY	(3) MAINTENANCE FUNCTION	(4) MAINTENANCE LEVEL				(5) TOOLS AND EQUIPMENT REF CODE	(6) REMARKS CODE	
			FIELD		SUSTAINMENT				
			UNIT		DS	GS			DEPOT
			C	O	F	H			D
06	ELECTRICAL SYSTEM - Continued								
	Electronic Control Units and Modules	Calibrate Replace Repair		1.0 2.0			1.0	108,128	A D
0609	Electronic Joystick Assembly and Wiring Harness	Replace		1.5				128	
	Lights								
	Headlights and Backup Light	Replace Repair		0.7 0.5				108,128 108,128	
	Taillights	Replace Repair		0.7 0.5				108,128 108,128	
	Blackout Lights	Replace		0.7				108,128	
	Side Marker Lights	Replace		0.7				108,128	
	Turn Signal Lights	Replace		0.7				108,128	
	Worklights	Replace Repair		0.7 0.5				108,128 108,128	
	Interior Light	Replace Repair		0.5 0.3				128 128	
	IR Lights	Replace		0.5				108,128	
0610	Sending Units, Sensors, Warning Switches								
	Oil Pressure Sensor	Replace		1.0				128	
	Oil Temperature Sensor	Replace		1.0				128	
	Water Temperature Sensor	Replace		1.0				128	
	Engine Sensors	Replace		1.5				61,107,113, 128	
	Hydraulic Filter Indicator Sensors	Replace		1.5				24,103,128	
	Transmission Sensors	Replace		1.5				107,128	
	Fuel Level Sending Unit	Replace		0.8				128	

MAINTENANCE ALLOCATION CHART (MAC) - CONTINUED

0289 00

Table 1. MAC for the RT 240 RTCH - Continued.

(1) GROUP NUMBER	(2) COMPONENT/ ASSEMBLY	(3) MAINTENANCE FUNCTION	(4) MAINTENANCE LEVEL				(5) TOOLS AND EQUIPMENT REF CODE	(6) REMARKS CODE	
			FIELD		SUSTAINMENT				
			UNIT		DS	GS			DEPOT
			C	O	F	H			D
06	ELECTRICAL SYSTEM - Continued								
	Boom Angle Sensor	Inspect Calibrate Replace		0.5 0.5 1.0			128 128 128		
	Boom Extension Sensor	Inspect Calibrate Replace		0.5 0.5 1.0			128 128 128		
	Tophandler Angle Sensor	Inspect Calibrate Replace		0.5 0.5 1.0			128		
0611	Horn and Alarms								
	Electric Horn	Replace		1.0			128		
	Backup Alarm	Replace		0.7			128		
0612	Batteries								
	Batteries	Inspect Test Service Replace	0.2	1.0 1.0 1.7			107 107,108,128 107,108,128		
	Cables	Inspect Replace	0.4	1.0			108,128		
	Master Battery Switch	Replace		0.9			128		
	Slave Receptacle	Replace		1.0			128		
0613	Electrical Wiring Harnesses								
	Engine and Transmission Harness	Test Replace Repair		3.0 2.0		14.0 4.0	108,128 107,128		
	Instrument Panel Harness	Test Replace		2.0 4.0			107,128 128		
	Cab Harness	Test Replace		1.5 8.0			107,128 128		
	Cab to Chassis Harness	Test Replace		2.5	14.0		107,128		
	Boom and Tophandler Harness	Test Replace		2.0	6.0		107,128 103,128		

MAINTENANCE ALLOCATION CHART (MAC) - CONTINUED

0289 00

Table 1. MAC for the RT 240 RTCH - Continued.

(1) GROUP NUMBER	(2) COMPONENT/ ASSEMBLY	(3) MAINTENANCE FUNCTION	(4) MAINTENANCE LEVEL				(5) TOOLS AND EQUIPMENT REF CODE	(6) REMARKS CODE	
			FIELD		SUSTAINMENT				
			UNIT		DS	GS			DEPOT
			C	O	F	H			D
07	TRANSMISSION								
0700	Transmission Assembly	Inspect	0.5						
		Service		1.0			107,128		
		Replace			55.0		106,107,128		
		Repair		2.0	4.0	65.0			
	Hoses	Replace		4.5			128		
0705	Transmission Shifting Components								
0708	Torque Converter	Replace			2.0		107,128		
0721	Filters, Breathers, and Coolers								
	Oil Filters	Replace		1.5			107,128		
	Oil Cooler Assembly	Replace		4.0			107,128		
	Hoses	Replace		3.5			107,128		
	Oil Sampling Valve	Replace		0.5			128		
09	PROPELLER AND PROPELLER SHAFTS								
0900	Propeller Shafts	Inspect		0.7					
		Replace		2.0			107,128		
	Universal Joints	Inspect		0.5					
		Service		0.7			107		
		Replace		2.0			107,108,128		
10	FRONT AXLE								
1000	Front Axle Assembly	Inspect		0.7					
		Service		2.0			107,128		
		Replace			24.0		106,107,128		
		Repair				48.0			
	Front Kingpin	Replace				27.5			
		Repair				8.0			
1002	Front Differential	Service		2.0		32.0	107,128		
		Replace				12.0			
		Repair							

MAINTENANCE ALLOCATION CHART (MAC) - CONTINUED

0289 00

Table 1. MAC for the RT 240 RTCH - Continued.

(1) GROUP NUMBER	(2) COMPONENT/ ASSEMBLY	(3) MAINTENANCE FUNCTION	(4) MAINTENANCE LEVEL				(5) TOOLS AND EQUIPMENT REF CODE	(6) REMARKS CODE	
			FIELD		SUSTAINMENT				
			UNIT		DS	GS			DEPOT
			C	O	F	H			D
09	PROPELLER AND PROPELLER SHAFTS - Continued								
1003	Front Planetary Wheel Ends	Service Replace Repair		1.5		26.0 25.0	107,128	D D	
11	REAR AXLE								
1100	Rear Axle Assembly	Inspect Service Replace		0.7 2.0	21.0		107,128 105,111,126, 128	A D	
	Rear Kingpin	Repair Replace Repair				65.0 22.0 8.0		D D D	
1102	Rear Differential	Service Replace Repair		2.0		32.0 12.0	107,128	D D	
1103	Rear Planetary Wheel Ends	Service Replace Repair		1.5		26.0 25.0	107,128	D D	
12	BRAKES								
1201	Parking Brake Brake Cylinder	Replace Repair			2.5	2.5	106,128,139 106,128,139	D	
	Brake Pads Front/Rear	Inspect Adjust Replace		0.5 1.0 2.0			107,128,139 107,128,139		
1202	Services Brakes Front Brake Pads	Inspect Replace			1.5	1.5	41,128	D	
	Rear Brake Pads	Inspect Replace			1.5	1.5	41,128	D	
1204	Hydraulic Brake System Brake Control Valves	Inspect Replace		1.5 2.0			128		
	Accumulators	Service Replace			1.5 2.5		69,107,128 107,108,128		

MAINTENANCE ALLOCATION CHART (MAC) - CONTINUED

0289 00

Table 1. MAC for the RT 240 RTCH - Continued.

(1) GROUP NUMBER	(2) COMPONENT/ ASSEMBLY	(3) MAINTENANCE FUNCTION	(4) MAINTENANCE LEVEL					(5) TOOLS AND EQUIPMENT REF CODE	(6) REMARKS CODE	
			FIELD		SUSTAINMENT					
			UNIT		DS	GS	DEPOT			
			C	O	F	H	D			
12	BRAKES - Continued									
	Brake Hoses, Lines, and Fittings	Inspect Replace		1.5 2.5				107,128		
	Brake System Cooling Filters	Replace		1.5				107,128		
1206	Mechanical Brakes	Replace		4.0				128		
13	WHEELS									
1311	Wheel Assembly	Inspect Replace	0.5	0.5				20,107,128, 132,136		
		Repair				3.0		G		
	Bogie Wheels and Tires	Replace Repair			14.0 4.0					
	Dolly Wheels and Tires	Inspect Replace Repair	0.5	0.5				107,112,128 107,112,128		
1313	Tires, Tubes, Tire Chains	Replace			2.5 3.0 4.0			107,128		
14	STEERING									
1401	Mechanical Steering									
	Steering Wheel	Replace		0.5				128		
	Adjustable Steering Column	Inspect Replace Repair	1.0		4.0			128 128		
1410	Hydraulic Steering System									
	Tophandler and Steering Hydraulic Pump Assembly	Adjust Replace Repair			1.0 8.0		28.0	128 107,112,128		
	Emergency Steering Pump	Replace			4.0			107,108,128		
1411	Hoses, Lines, and Fittings	Replace		4.5				107,128		
1412	Front Steering Cylinders	Replace Repair		1.5			16.0	107,128		
								F D		

MAINTENANCE ALLOCATION CHART (MAC) - CONTINUED

0289 00

Table 1. MAC for the RT 240 RTCH - Continued.

(1) GROUP NUMBER	(2) COMPONENT/ ASSEMBLY	(3) MAINTENANCE FUNCTION	(4) MAINTENANCE LEVEL				(5) TOOLS AND EQUIPMENT REF CODE	(6) REMARKS CODE	
			FIELD		SUSTAINMENT				
			UNIT		DS	GS			DEPOT
			C	O	F	H			D
14	STEERING - Continued								
	Rear Steering Cylinders	Replace		2.0					
		Repair			4.0				
1414	Steering System Valves and Accumulator								
	Steering Control Valves	Replace			6.0		107,112,128		
	Accumulator	Service			1.5		106,128		
		Replace			2.5		107,128		
	Steering Sensor	Replace		2.5			128		
15	FRAME ASSEMBLY								
1501	Frame Components	Inspect			1.5				
	Skid Plates and Access Covers	Replace		2.5			107,128		
	Wear Plates	Inspect		1.0			128		
		Replace		2.5			107,128		
1503	Pintle Hook	Inspect	0.2						
		Service	0.2						
		Replace		0.5			108,128		
1507	Bogie Wheel Frame	Replace		8.0			128		
18	BODY, CAB, AND HOOD								
1801	Cab Assembly	Inspect	1.0						
		Replace			22.0				
		Repair			30.0		D		
	Cab Support Frame	Replace		4.0			D		
		Repair			32.0		D		
	Cab Lift Frame	Replace		4.0			112,128		
		Repair		1.0			128		
	Cab Door	Replace			2.5		128		
		Repair			1.5		128		
	Right Side Step	Replace		5.0			128		
		Repair		2.5			128		
	Left Side Step	Replace		12.0			128		
		Repair		1.0			128		

MAINTENANCE ALLOCATION CHART (MAC) - CONTINUED

0289 00

Table 1. MAC for the RT 240 RTCH - Continued.

(1) GROUP NUMBER	(2) COMPONENT/ ASSEMBLY	(3) MAINTENANCE FUNCTION	(4) MAINTENANCE LEVEL					(5) TOOLS AND EQUIPMENT REF CODE	(6) REMARKS CODE	
			FIELD		SUSTAINMENT					
			UNIT		DS	GS	DEPOT			
			C	O	F	H	D			
18	BODY, CAB, AND HOOD - Continued									
	Storage Compartment	Replace		16.0				107,128		
		Repair		1.0				128		
	Engine Cover	Replace		1.0				107,128		
1802	Fenders, Windshields, Glass, Attaching Parts	Replace		1.5				106,107,128		
	Fender Assembly	Replace		4.5				128		
1806	Seat Assembly	Inspect	0.5							
		Replace		2.0				102,107,128		
		Repair		1.0				128		
	Seat Belt Assembly	Inspect	0.1							
		Replace		1.5				128		
22	ACCESSORY ITEMS									
2202	Accessory Items									
	Mirrors	Inspect	0.2							
		Adjust	0.2							
		Replace		0.8				128,131		
	Front, Rear, and Roof	Inspect	0.2							
	Windshield Wipers	Replace		0.4				128,131		
	Windshield Washer and Motor	Service	0.4							
		Replace		1.5				128,131		
	Heater Hoses	Replace		2.0				107,128		
	Heater/Air	Test		1.3				70		
	Conditioning Unit	Replace			4.0			107,128		
		Repair			4.5			100,107,128		
	Blower Motor and Fan	Replace		6.0				128		
	Autolube System	Replace		4.0				128		
2210	Data Plates	Replace		1.5				107,128		
24	HYDRAULIC AND FLUID SYSTEMS									
2400	Hydraulic System	Test		3.0				1,44,107,128		
2401	Boom and Brake	Replace			8.0			107,112,128		
	Hydraulic Pump	Repair				24.0		A,F D		

MAINTENANCE ALLOCATION CHART (MAC) - CONTINUED

0289 00

Table 1. MAC for the RT 240 RTCH - Continued.

(1) GROUP NUMBER	(2) COMPONENT/ ASSEMBLY	(3) MAINTENANCE FUNCTION	(4) MAINTENANCE LEVEL				(5) TOOLS AND EQUIPMENT REF CODE	(6) REMARKS CODE	
			FIELD		SUSTAINMENT				
			UNIT		DS	GS			DEPOT
			C	O	F	H			D
24	HYDRAULIC AND FLUID SYSTEMS - Continued								
	Cooling Fan Hydraulic Pump	Replace Repair			4.0		12.0	107,128	F D
	Cooling Fan Hydraulic Motor	Replace Repair			4.0		7.0	128	F D
	Hydraulic System Auxiliary Pump	Replace		1.5				128	F
	Tophandler Slewing Motor Assembly	Replace Repair		6.0 2.0	22.0			107,112,128 128	A,F
	Tophandler Slewing Motor	Replace Repair		2.0		12.0		128 128	
	Gear Cluster and Brake	Replace							
	Tophandler Spreader Motor Assembly	Replace Repair		8.0		12.0		128 128	
	Tophandler Spreader Motor	Replace		2.0				128	
	2402	Main Flow Control Valve Assembly	Replace Repair			8.0		30.0	107,112,128
Steering System Flow Control Valve		Replace Repair			6.0 2.0		6.0	128 128	D
Lift Cylinder Flow Control Valve		Replace Repair			2.0		12.0	128	D
Boom Folding Flow Control Valve		Replace Repair			5.0 1.0		1.0	128 128	D
Cab Lowering Flow Control Valve		Replace Repair			5.0 1.0		1.0	128 128	D
2405		Strainers, Filters, Hoses, Tubes, and Fittings							
	Hoses, Lines, and Fittings	Inspect Replace	0.5		2.5			24,107,128	F
	Oil Sampling Valve	Replace			0.5			107,128	F
	Oil Filters	Replace			3.0			107,128,139	

MAINTENANCE ALLOCATION CHART (MAC) - CONTINUED

0289 00

Table 1. MAC for the RT 240 RTCH - Continued.

(1) GROUP NUMBER	(2) COMPONENT/ ASSEMBLY	(3) MAINTENANCE FUNCTION	(4) MAINTENANCE LEVEL				(5) TOOLS AND EQUIPMENT REF CODE	(6) REMARKS CODE	
			FIELD		SUSTAINMENT				
			UNIT		DS	GS			DEPOT
			C	O	F	H			D
24	HYDRAULIC AND FLUID SYSTEMS - Continued								
2406	Boom Servo Flow Control Valve	Replace Repair			6.0 2.5	6.0	107,128	A,F D	
	Tophandler Control Valves	Replace Repair			8.0 1.0	30.0	107,128	F D	
	Fan Flow Control Valve	Replace			2.0		128		
2407	Boom Lift Cylinder	Replace Repair			8.0	15.0	106,112,128	A,F D	
	Boom Extension Cylinder	Replace Repair			30.0	15.0		D,F D	
	Boom Folding Cylinders	Replace Repair			6.0	10.0	106,112,128	A,F D	
	Cab Lifting and Sliding Cylinders	Replace Repair		3.0	6.0		107,128 128	F	
	Bogie Wheel Lift Cylinders	Replace Repair			3.0	7.0	106,112,128	F D	
	Folding Boom Locking Pin Cylinders	Replace Repair			3.0	7.0	106,112,128 128	F	
	Tophandler Tilt Cylinders	Replace Repair			3.0	8.0	106,112,128	F D	
	Tophandler Side Shift Cylinders	Replace Repair			2.0	8.0	106,112,128 106,128	F	
	Tophandler Leveling Cylinders	Replace Repair			2.0	6.0	106,112,128 106,128	F	
	Twistlock Cylinders	Replace		1.0			107,128	F	
2408	Tanks and Reservoirs								
	Hydraulic Reservoir	Inspect Service Replace	0.5	1.5	26.0		128 107,128	F	
	Gage, Level	Replace		1.5			107,128		

MAINTENANCE ALLOCATION CHART (MAC) - CONTINUED

0289 00

Table 1. MAC for the RT 240 RTCH - Continued.

(1) GROUP NUMBER	(2) COMPONENT/ ASSEMBLY	(3) MAINTENANCE FUNCTION	(4) MAINTENANCE LEVEL				(5) TOOLS AND EQUIPMENT REF CODE	(6) REMARKS CODE	
			FIELD		SUSTAINMENT				
			UNIT		DS	GS			DEPOT
			C	O	F	H			D
32	BASIC ISSUE ITEMS, TROOP INSTALLED								
3200	Dolly Wheels	Inspect Replace Repair	0.3	2.0 1.0			128 128 E		
33	SPECIAL PURPOSE KITS								
3307	Forklift Assembly	Inspect Install Repair	0.5 0.5			10.0	107,128 D		
	Forklift Control Valve	Replace Repair		2.0		20.0	107,128 F D		
	Forklift Cylinders	Replace Repair		2.0		6.0	106,128 106,128 F		
	Forklift Manifold Valve	Replace			10.0		128		
52	REFRIGERATION, AIR CONDITIONER/ HEATER, AND AIR CONDITIONING COMPONENTS								
5200	Air Conditioning System	Inspect Service	0.5	0.5	2.0		70,128 100,107,128		
	Compressor	Replace			3.0		128		
	Belt	Adjust Replace		0.7 1.0			128 128		
5217	Valves and Lines	Replace			3.5		128		
5230	Condenser	Replace			2.5		128		
	Receiver/Dryer	Replace			3.0		128		
74	CRANES, SHOVELS, AND EARTHMOVING EQUIPMENT COMPONENTS								
7417	Lifting Boom	Inspect Replace Repair	1.0	1.0	24.0	60.0	103,108,128 A D		

MAINTENANCE ALLOCATION CHART (MAC) - CONTINUED

0289 00

Table 1. MAC for the RT 240 RTCH - Continued.

(1) GROUP NUMBER	(2) COMPONENT/ ASSEMBLY	(3) MAINTENANCE FUNCTION	(4) MAINTENANCE LEVEL					(5) TOOLS AND EQUIPMENT REF CODE	(6) REMARKS CODE	
			FIELD		SUSTAINMENT					
			UNIT		DS	GS	DEPOT			
			C	O	F	H	D			
74	CRANES, SHOVELS, AND EARTHMOVING EQUIPMENT COMPONENTS - Continued									
	Boom Support	Replace			40.0			106,128		
	Assembly	Repair			4.0			106,128		
	Slide Plate	Replace			7.0			128		
	Flexible Conveyor	Replace		8.0				128		
		Repair		3.5				128		
7421	Tophandler Assembly	Inspect	1.0	1.0						
		Replace		4.0				128		
		Repair				225.0				
	Chain Assembly	Inspect		1.5						
		Adjust		2.5				128		
		Replace		7.0				106,128		
	Hydraulic Hoses	Replace		8.0				128		
	Slide Plate (Wear Pads)	Replace		14.0				128		
	Twistlocks	Inspect	0.5							
		Adjust		1.5				128		
		Replace			2.5			106,128		

MAINTENANCE ALLOCATION CHART (MAC) - CONTINUED

0289 00

Table 8. Tools and Test Equipment Requirements for the RT 240 RTCH.

(1) ITEM NO.	(2) MAINTENANCE LEVEL	(3) ITEM NAME	(4) NATIONAL STOCK NUMBER	(5) PART NUMBER
1	O	Adapter, Quick Disconnect		PD260
2	F	Adapter, Wrench Torque		3163196
3	F	Adjustment Kit, Injector	4910-00-548-7984	3823610
4	F	Alignment Plate, Flywheel Housing		3376606
5	O	Apron, Utility, Impermeable	8415-00-082-6108	8415-00-082-6108
6	F	Attachment, Dial	4910-01-097-6972	ST-1325
7	F	Barring Tool, Engine		3824270
8	F	Bearing Kit, Needle		3823774
9	O	Belt, Tension Gage	5220-01-141-5776	ST1138
10	F	Bracket, Lifting, Cylinder Head		3822479
11	O	Cable, Breakout: Ambient Air Pressure Sensor		3824774
12	O	Cable, Breakout Pressure Sensor		3824775
13	O	Cable, Breakout Pressure Sensor		3824776
14	O	Cable, Breakout Pressure/Temperature Sensor		3162898
15	O	Cable, Test/Repair		3823256
16	F	Caliper, Inside Firm joint, 12 in. size	5210-00-189-9640	27-12
17	H	Caliper, Micrometer, Inside 2 to 12 in. range	5210-00-221-1921	124BZ
18	F	Caliper, Micrometer, Outside 0 to 1 in. range	5210-00-540-2973	T230RL
19	F	Caliper, Vernier English and Metric Measurements, 0 to 6 in. and 1 to 150 mm	5210-01-113-1548	GGG-C-111
20	F	Chain Assembly, Single Leg 14 ft long	4010-00-171-4426	R-R-C-271
21	O	Clamp, C-	5120-00-203-6431	A-A-431
22	H	Compressor, Piston Ring		3823309
23	F	Compressor, Valve Spring	5120-01-145-7293	ST-448
24	O	Crowfoot Attachment Set Socket wrench, 1/2 in. drive	5120-01-429-1109	216FCOM

MAINTENANCE ALLOCATION CHART (MAC) - CONTINUED

0289 00

Table 8. Tools and Test Equipment Requirements for the RT 240 RTCH - Continued.

(1) ITEM NO.	(2) MAINTENANCE LEVEL	(3) ITEM NAME	(4) NATIONAL STOCK NUMBER	(5) PART NUMBER
25	O	Dispenser, Sealant	5120-00-061-1283	45RCT
26	O	Drill Set, Twist	5133-00-293-0983	800434
27	O	Drill, Electric, Portable 3/8 in. size	5130-00-935-7354	6635
28	H	Driver		3376070
29	H	Driver, Expansion Plug	4910-01-143-3337	3376816
30	H	Driver, Expansion Plug		3822372
31	F	Driver, Gear, Fuel Pump		3823581
32	F	Driver, Injector Sleeve	5120-00-981-3108	ST-1227
33	H	Expander, Piston Ring		ST-821
34	F	Expander, Tube	3441-00-922-6699	ST880
35	H	Extractor, Dowel Pin		3163720
36	F	Extractor, Valve Seat		3376146
37	F	Fixture, Engine Lifting		3162871
38	F	Gage, Capscrew, Cylinder Head		3823546
39	F	Gage, Depth	4910-00-238-9957	ST-537
40	F	Gage, Depth, Dial Indicating	5210-01-157-3091	3164438
41	F	Gage, Depth, Micrometer: 0 to 6 in. range	5210-00-619-4045	52-225-015
42	H	Gage, Master Ring		3376576
43	F	Gage, Pressure, Dial Indicating	6620-01-382-1206	3375275
44	O	Gage, Pressure, Multiple Dial Indicating	4940-01-086-8756	123221E6828
45	F	Gage, Thickness 0.051 to 1.00 mm	5210-01-045-3526	66MA
46	O	Gage, Tire Pressure	4910-00-204-3170	7188BH
47	O	Gloves, Chemical and Oil, Protective, Rubber	5415-00-641-4601	ZZ-G-381
48	O	Gloves, Welders, Leather	8415-00-268-7859	A-A-50022
49	O	Goggles, Industrial	4240-00-052-3776	A-A-1110
50	O	Goggles, Industrial	4240-00-816-3819	WA60-5H0746-0315
51	H	Guide		3376069
52	H	Guide, Camshaft Pilot		3376388
53	F	Hammer, Hand, Plastic	5120-01-065-2211	57-534

MAINTENANCE ALLOCATION CHART (MAC) - CONTINUED

0289 00

Table 8. Tools and Test Equipment Requirements for the RT 240 RTCH - Continued.

(1) ITEM NO.	(2) MAINTENANCE LEVEL	(3) ITEM NAME	(4) NATIONAL STOCK NUMBER	(5) PART NUMBER
54	F	Hammer, Slide, Mechanical	5120-00-313-9498	4056H
55	O	Handle, Socket Wrench	5120-00-709-4072	L52BH
56	O	Heater, Gun	4940-00-561-1002	6966C
57	F	Holding Tool, Injector Sleeve	5120-00-104-1795	ST1179
58	F	Indicator, Dial	5210-01-157-2291	3376050
59	F	Insert Kit, Valve Seat	4910-00-345-3708	ST-257
60	H	Insertor, Bearing and Bushing	5120-01-156-6186	3376637
61	O	Installation Tool, EPS		3822759
62	H	Installation Tool, Needle Bearing		3824117
63	F	Installation Tool, Seal, Valve		3823946
64	H	Installation/Removal Tool, Cam Follower		3824519
65	F	Jack Kit, Hydraulic, Hand 20 ton capacity	5120-00-595-8387	A-A-312
66	O	Jack, Hydraulic, Hand 12 ton capacity	5120-00-224-7330	67224
67	O	Key Set, Socket Head Screw	5120-00-935-4641	56011
68	F	Kit, Dye	4820-01-446-7489	3376891
69	F	Kit, Nitrogen Charging	1025-01-070-3200	8449334
70	O	Leak Detector, Refrigerant	4940-01-387-0948	16500
71	H	Liner/Installation Tool		3824272
72	O	Lubricating Gun, Hand	4930-00-253-2478	1142
73	O	Multimeter, Digital	6625-01-139-2512	T00377
74	F	Multimeter, Digital	6625-01-265-6000	27FM W/ACCE
75	O	Multiplier, Torque Wrench	5120-00-169-2986	PD1201
76	O	Pan, Drain 4 gal. capacity	4910-00-387-9592	450
77	F	Pin Kit, Guide		3376695
78	F	Pin, Guide		3376488
79	H	Pins, Guide, Connecting Rod		3376038
80	H	Plate, Adapter, Engine Stand		3376432
81	O	Pliers, Retaining Ring External, 0.038 to 1.000 in. diameter	5120-00-288-9717	0200
82	O	Pliers, Retaining Ring Internal, 1.02 to 1.37 ring size	5120-00-293-0048	0100

MAINTENANCE ALLOCATION CHART (MAC) - CONTINUED

0289 00

Table 8. Tools and Test Equipment Requirements for the RT 240 RTCH - Continued.

(1) ITEM NO.	(2) MAINTENANCE LEVEL	(3) ITEM NAME	(4) NATIONAL STOCK NUMBER	(5) PART NUMBER
83	O	Pliers, Retaining Ring Internal, 1.75 to 2 in. ring size	5120-00-293-0045	0300
84	F	Press, Arbor Hand operated	3444-00-449-7295	A-A-51194
85	F	Puller and Driver, Injector		3823579
86	H	Puller Kit, Cam Gear		3162895
87	H	Puller Kit, Camshaft Gear		3824106
88	H	Puller Kit, Universal	5180-01-104-2762	3375784
89	H	Puller Kit, Universal	5180-01-178-5332	3375840
90	H	Puller Kit, Universal	5180-01-104-2762	3375784
91	H	Puller Kit, Universal	5180-01-178-5332	3375840
92	F	Puller Kit, Universal	5180-00-313-9496	1178
93	O	Puller, Battery Terminal	5120-00-944-4268	21
94	H	Puller, Cylinder Liner		3163745
95	H	Puller, Main Bearing Cap	5120-01-141-5779	ST-1178
96	H	Puller, Mechanical	5120-01-331-6468	3375082
97	F	Puller, Mechanical	5120-00-113-5271	3377079
98	O	Puller, Mechanical	5120-01-156-4183	3376326
99	O	Puller, Mechanical	5120-00-499-1489	ST-647
100	F	Reclaimer, Refrigerant, R-134A	4250-01-396-8928	EEEAC304A
101	F	Removal Tool, Valve Guide		3823271
102	O	Riveter, Blind, Hand 3/32 in., 1/8 in., 5/32 in., and 3/16 in. diameters	5120-00-017-2849	98
103	O	Screwdriver Set, Jeweler's	5120-00-288-8739	250
104	F	Separator Tool, Bearing	5120-01-128-2674	3375326
105	F	Shackle, Lifting	4030-00-169-9298	358T1 1-2
106	F	Shop Equipment, Automotive Maintenance and Repair: Field Maintenance, Basic, Less Power	4910-00-754-0705	SC 4910-95-A31
107	O	Shop Equipment, Automotive Maintenance and Repair: Organizational Maintenance, Common No.1	4910-00-754-0654	SC 4910-95-A74

MAINTENANCE ALLOCATION CHART (MAC) - CONTINUED

0289 00

Table 8. Tools and Test Equipment Requirements for the RT 240 RTCH - Continued.

(1) ITEM NO.	(2) MAINTENANCE LEVEL	(3) ITEM NAME	(4) NATIONAL STOCK NUMBER	(5) PART NUMBER
108	O	Shop Equipment, Automotive Maintenance and Repair: Organizational Maintenance, Common No. 2	4910-00-754-0650	SC 4910-95-A72
109	F	Sling, Endless	3940-01-183-9412	3375957
110	F	Sling, Engine and Transmission	4910-01-243-5556	DFP-188
111	F	Sling, Eye	3940-01-334-0749	EE1-202
112	O	Sling, Nylon	2835-01-078-2081	4-8FTX2IN
113	O	Socket, Deep Well 1-1/4 in.		3823843
114	F	Socket, Socket Wrench 46 mm	5130-01-113-1565	IMM462
115	F	Soldering Gun	3439-00-618-6623	D550-3
116	H	Stand, Engine Rebuild	4910-01-128-2686	3375194
117	F	Stand, Engine Support		3376057
118	O	Tape, Measuring 50 ft long	5210-00-554-7085	403
119	O	Tape, Measuring 50 ft long	5210-00-234-6745	C213
120	F	Test Kit, Pressure, Lubricating Oil Cooler		3376861
121	O	Test Lead, Female		3822917
122	O	Test Lead, Female		3823994
123	O	Test Lead, Female		3823996
124	O	Test Lead, Male		3822758
125	F	Tester, Valve Spring	4910-01-142-4929	3375182
126	F	Tool Kit, Automotive Fuel and Electrical System Repair	5180-00-754-0655	SC 5180-95-B08
127	O	ToolKit,ElectricalConnectorRepair	5180-00-876-9336	7550526
128	O	Tool Kit, General Mechanic's Automotive	5180-00-177-7033	SC 5180-95-N26
129	F	Trestle, Hoist, Portable 7 ton capacity	3950-00-251-8013	306
130	O	Vise, Machinist's	5120-00-293-1439	504M2
131	O	Wrench Set, Socket Attachment Screwdriver, torx, 1/4 and 1/8 in. drive	5120-01-178-6342	J29843

MAINTENANCE ALLOCATION CHART (MAC) - CONTINUED

0289 00

Table 8. Tools and Test Equipment Requirements for the RT 240 RTCH - Continued.

(1) ITEM NO.	(2) MAINTENANCE LEVEL	(3) ITEM NAME	(4) NATIONAL STOCK NUMBER	(5) PART NUMBER
132	F	Wrench Set, Socket, Impact	5130-00-357-5136	B107.2
133	F	Wrench Set, Socket 3/4 in. drive	5120-00-204-1999	FEDSTD353
134	F	Wrench Set, Socket 1 in. drive	5120-00-081-2309	A-A-1392
135	O	Wrench, Adjustable 3-5/8 in. jaw, 15 in. long	5120-00-264-3793	2117080
136	F	Wrench, Impact, Pneumatic	5130-00-542-3230	5130-00-542-3230
137	O	Wrench, Strap	5120-01-262-7306	3898145
138	O	Wrench, Strap, Oil Filter	5120-00-020-2947	2432097
139	O	Wrench, Strap, Pipe	5120-00-242-3249	D170X
140	F	Wrench, Torque	5120-01-348-0959	3376592
141	F	Wrench, Torque 3/4 in. drive, 100 to 600 lb-ft capacity	5120-01-113-9564	7379
142	O	Wrench, Torque 3/8 in. drive, 0 to 200 lb-in. capacity	5120-00-853-4538	F200
143	O	Wrench, Torque 3/8 in. drive, 0 to 300 lb-in. capacity	5120-00-776-1841	2163993
144	O	Wrench, Torque 3/8 in. drive, 15 to 75 lb-ft capacity	5120-01-355-1739	QC2FR75
145	O	Wrench, Torque 50 to 250 lb-ft capacity	5120-01-042-0982	VB-2503MFR

Table 3. Remarks for the RT 240 RTCH.

(1) Reference Code	(2) Remarks
A	<p>Prior to removing a major assembly or component, contact Specialized Repair Activity (SRA) for possible further troubleshooting information and/or shipping instructions.</p> <p>For SRA assistance, call Kalmar RT Center (KRTC) at:</p> <ul style="list-style-type: none"> • 1-800-558-7232, ext 24 • 1-210-599-3478, ext 24 • 1-210-599-4009 (Fax) • E-mail to: rtch@kalmarRT.com <p>For RT 240 RTCH information and FAQ, visit the KRTC web site: www.kalmarRT.com</p>
B	Refer to TM 750-254 (cooling systems) for additional information.
C	Refer to TM 9-6140-200-14 (batteries) for additional information.
D	<p>Replacement or repair responsibility is assigned to Specialized Repair Activity (SRA).</p> <p>For SRA assistance, call Kalmar RT Center (KRTC) at:</p> <ul style="list-style-type: none"> • 1-800-558-7232, ext 24 • 1-210-599-3478, ext 24 • 1-210-599-4009 (Fax) • E-mail to: rtch@kalmarRT.com <p>For RT 240 RTCH information and FAQ, visit the KRTC web site: www.kalmarRT.com</p>
E	Refer to TM 9-2610-200-14 (tires) for additional information.
F	The replacement of hydraulic reservoir return filters is required after 100 hours of operation, following any hydraulic system maintenance action that resulted in the hydraulic system being opened.
G	Local repair of tire and wheel assembly is authorized.

END OF WORK PACKAGE

EXPENDABLE AND DURABLE ITEMS LIST

0290 00**SCOPE**

This work package lists expendable and durable items you will need to maintain the RTCH. This listing is for information only and is not authority to requisition the listed items. These items are authorized to you by CTA 50-970, *Expendable/Durable Items (Except Medical, Class V Repair Parts, and Heraldic Items)*, or CTA 8-100, *Army Medical Department Expendable/Durable Items*.

EXPLANATION OF COLUMNS

1. **Column (1) - Item Number.** This number is assigned to the entry in the list and is referenced in the narrative instructions to identify the item [e.g., Use Abrasive Pad (Item 1, WP 0290 00)].
2. **Column (2) - Level.** This column identifies the lowest level of maintenance that requires the listed item.
 - F- Direct Support Maintenance
 - H- General Support Maintenance
3. **Column (3) - National Stock Number (NSN).** This is the NSN assigned to the item which you can use to requisition it.
4. **Column (4) - Description, Item Name, Commercial and Government Entity Code (CAGEC), and Part Number (P/N).** This provides the other information you need to identify the item.
5. **Column (5) - Unit of Measure (U/M).** This code shows the physical measurement or count of an item, such as gallon, dozen, gross, etc.

Table 1. Expendable and Durable List for the RT 240 RTCH.

(1) ITEM NUMBER	(2) LEVEL	(3) NATIONAL STOCK NUMBER	(4) DESCRIPTION, CAGEC, AND PART NUMBER	(5) U/M
1	F		Abrasive Pad (15434) 3823258	EA
2	O		Adhesive (71984) RTV732	
3	C	8040-00-877-9872	3 Ounce Tube	OZ
4	C	6850-00-174-1806	Antifreeze, Permanent: Arctic Grade (81349) MILA11755 55 Gallon Drum	GAL
		6850-00-181-7929	1 Gallon Bottle	GAL
		6850-00-181-7933	5 Gallon Can	GAL
		6850-00-181-7940	55 Gallon Drum	GAL
5	O	5340-00-450-5718	Cap Set, Protective Dust and Moisture Seal (19207) 10935405	EA
6	O		Cloth, Abrasive, Emery, Fine (80204) ANSI B74.18	
		5350-00-584-4654	50 Sheet Package	EA
7	O		Compound, Antiseize (05972) 76764	
		8030-00-251-3980	1 Pound Can	LB
8	F		Compound, Antiseize High Temperature (73165) 51008	
		8030-00-597-5367	2.5 Pound Can	LB
9	C		Compound, Cleaning, Windshield (81348) O-C-1901	
		6850-00-926-2275	16 Ounce Can	OZ
10	O		Compound, Gasket Forming, Silicone (05972) 77C	OZ
			13 Ounce Cartridge	OZ
11	F		Compound, Gasket Forming High Tack (77247) 98D	
		5330-00-151-6659	1 Pint Can	

Table 1. Expendable and Durable List for the RT 240 RTCH - Continued.

(1) ITEM NUMBER	(2) LEVEL	(3) NATIONAL STOCK NUMBER	(4) DESCRIPTION, CAGEC, AND PART NUMBER	(5) U/M
12	O	8030-00-111-2763 8030-00-111-2762	Compound, Sealing (81349) MIL-S-46163 10 cc Bottle, Box of 10 Bottles 50 cc Bottle	CC CC
13	F	8030-01-392-3276	Compound, Sealing Dissimilar Metal Protection (71961) 6099 1 Gallon Can	GAL
14	O	8030-00-081-2327 8030-00-081-2286	Compound, Sealing, Pipe (05972) 079-21 10 cc Bottle, Box of 10 Bottles 50 cc Bottle	CC CC
15	C	7930-00-282-9699	Detergent General Purpose Liquid (81348) P-D-220 1 Gallon Can	GAL
16	O	3439-00-255-9935	Flux, Soldering (58536) A-A-51145TY1 FORM A 1 Pound Can	LB
17	C	9140-00-286-5286 9140-00-286-5287 9140-00-286-5288	Fuel, Diesel, DF-1 Grade, Winter (81346) ASTM D 975 Bulk 5 Gallon Can 55 Gallon Drum	GAL GAL GAL
18	C	9140-00-286-5294 9140-00-286-5295 9140-00-286-5296	Fuel, Diesel, DF-2 Grade (81346) ASTM D 975 Bulk 5 Gallon Can 55 Gallon Drum	GAL GAL GAL
19	C	9130-01-031-5816	Fuel, Turbine, Aviation (81349) milt83133 GR JP8	GAL

Table 1. Expendable and Durable List for the RT 240 RTCH - Continued.

(1) ITEM NUMBER	(2) LEVEL	(3) NATIONAL STOCK NUMBER	(4) DESCRIPTION, CAGEC, AND PART NUMBER	(5) U/M
20	C	9150-01-197-7688	Grease, Automotive and Artillery, GAA (81349) M-10924-A 1-1/4 Ounce Tube	OZ
		9150-01-197-7693	(81349) M-10924-B 14 Ounce Cartridge	OZ
		9150-01-197-7690	(81349) M-10924-C 2-1/4 Pound Can	LB
		9150-01-197-7692	(81349) M-10924-E 35 Pound Can	LB
21	O	9150-01-361-8919	Grease, Electrically Conductive (47224) 5190179	OZ
22	F	7050-00-961-7663	Lubriplate, Lubricant (90536) ST40334	OZ
23	F	9150-00-825-6131	Oil, Cutting (77247) 22F 1 Gallon Can	GAL
24	F	9150-01-035-5392 9150-01-313-2191 9150-00-001-9395 9150-01-035-5394	Oil, Lubricating, GO 80W/90 (81349) MIL-PRF-2105 1 Quart Can 1 Gallon Can 5 Gallon Can 55 Gallon Drum	QT GAL GAL GAL
25	O	9150-01-048-4591 9150-01-035-5395 9150-01-035-5396	Oil, Lubricating, GO 85W/140 (81349) MIL-PRF-2105 1 Quart Can 5 Gallon Can 55 Gallon Drum	QT GAL GAL
26	C	9150-00-189-6727 9150-00-186-6668 9150-00-191-2772	Oil, Lubricating, OE/HDO 10 (81349) MIL-L-2104 1 Quart Can 5 Gallon Can 55 Gallon Drum	QT GAL GAL

Table 1. Expendable and Durable List for the RT 240 RTCH - Continued.

(1) ITEM NUMBER	(2) LEVEL	(3) NATIONAL STOCK NUMBER	(4) DESCRIPTION, CAGEC, AND PART NUMBER	(5) U/M
27	C	9150-01-152-4117 9150-01-152-4118 9150-01-152-4119	Oil, Lubricating, OE/HDO 15/40 (81349) MIL-L-2104 1 Quart Can 5 Gallon Can 55 Gallon Drum	QT GAL GAL
28	C	9150-00-402-4478 9150-00-402-2372 9150-00-491-7197	Oil, Lubricating, OEA, Arctic (81349) MIL-L-46167 1 Quart Can 5 Gallon Can 55 Gallon Drum	QT GAL GAL
29	F	9150-01-410-8972 9150-01-410-8972	Oil, Lubricating, Refrigerant Compressor, Synthetic Ester (59595) CAPELLA HFG-68NA 1 Quart Can	QT
30	C	7290-00-205-1711	Rag, Wiping (64067) 7920-00-205-1711 50 Pound Bale	LB
31	F		Sealant (15434) 3824038	OZ
32	F		Sealant, Cup Plug (15434) 3375068	OZ
33	O		Sealant, Pipe (15434) 3375066	OZ
34	O		Sealant, Silicone (15434) 3823494	OZ
35	O	3439-00-555-4629	Solder Lead-Tin Alloy, Rosin Core (15434) 3823494 1 Pound Spool	LB
36	C	6850-01-377-1808 6850-01-331-3349 6850-01-331-3350	Solvent, Dry Cleaning, Type III (81348) P-D-680 1 Quart Container 5 Gallon Can 55 Gallon Drum	QT GAL GAL

Table 1. Expendable and Durable List for the RT 240 RTCH - Continued.

(1) ITEM NUMBER	(2) LEVEL	(3) NATIONAL STOCK NUMBER	(4) DESCRIPTION, CAGEC, AND PART NUMBER	(5) U/M
37	O	5975-00-903-2284	Strap, Tiedown Electrical Components (96906) MS3367-4-0 4 Inch Length, Black Package of 100	EA
		5975-00-984-6582	(96906) MS3367-1-0 6 Inch Length, Black Package of 100	EA
		5975-00-935-5946	(96906) MS3367-2-1 13 Inch Length, Brown Package of 100	EA
38	O	9905-00-537-8954	Tag, Marker (64067) 9905-00-537-8954 Pack of 50	EA
39	O	5640-00-103-2254	Tape, Duct 2 Inches Wide (39482) 1791K70 60 Yard Roll	YD
40	F	6830-01-439-0614	Tetrafluoroethane Technical Refrigerant, R-134A (4V886) R134A 43 Pound Cylinder	LB
41	O	5970-00-815-1295	Tubing: Heat Shrinkable (81349) M23053/5-106-0 250 Foot Spool	FT
42	F	8305-01-301-1031	Wipes, Lint-Free (28480) 92193W	EA
43	O	9905-00-596-0191	Wire, Nonelectrical (81346) ASTM A641 5 Pound Coil	LB

END OF WORK PACKAGE

INDEX

<i>Subject</i>	<i>Work Package/Page</i>
Numerics	
50A Circuit Breakers	
Installation	0074 00-8
Removal	0074 00-8
A	
Accessory Control Lever, Transmission, Replacement	0114 00-1
Accessory Drive Assembly Maintenance	0213 00-1
Accumulator	
Brake Replacement	0230 00-1
Service, Brake and Steering	0231 00-1
Steering, Replacement	0237 00-1
Adjustment	
Steering Hydraulic Pumps	0243 00-1
Tophandler Hydraulic Pump	0243 00-1
Valve and Injector	0207 00-1
Air Cleaner, Engine, Maintenance	0057 00-1
Air Conditioner	
Compressor Replacement	0266 00-1
Condenser Replacement	0268 00-1
Fans Maintenance	0196 00-1
Hoses Replacement	0267 00-1
Leak Test	0194 00-1
Receiver/Dryer Replacement	0269 00-1
Air Conditioning	
Blower Motor Replacement	0191 00-1
Compressor Drive Belts Replacement	0195 00-1
Fan Replacement	0191 00-1
Air Conditioning System Maintenance	0265 00-1
Air Conditioning Unit/Cab Heater Replacement	0264 00-1
Air Filters Replacement, Cab	0192 00-1
Alternator	
Drive Belt Maintenance	0071 00-1
Replacement	0070 00-1
Ambient Temperature Sensor Replacement	0092 00-1
Arctic Operation, Preparation for	0282 00-1
Autolube System Maintenance	0141 00-1
Auxiliary Fan Replacement, Cab	0193 00-1
Auxiliary Hydraulic Pump Replacement	0165 00-1
Auxiliary Pump Troubleshooting	0037 00-1

INDEX - Continued

Subject *Work Package/Page*

A - Continued

Axle Assembly Replacement	
Front	0227 00-1
Rear	0228 00-1

B

Backup Alarm Replacement	0106 00-1
Backup Light Maintenance	0085 00-1
Battery Cables Replacement	0110 00-1
Battery Maintenance	0108 00-1
Blackout Light Maintenance	0087 00-1
Bogie Wheel Assembly Maintenance	0233 00-1
Boom	
In/Out Troubleshooting	0041 00-1
Lifting/Lowering Troubleshooting	0040 00-1
Boom and Brake System Hydraulic Pump Replacement	0246 00-1
Boom and Tophandler Calibration	0259 00-1
Boom Angle Sensor Replacement	0099 00-1
Boom Assembly Replacement	0258 00-1
Boom Assembly Wear Plates Replacement	0146 00-1
Boom Extension Sensor Replacement	0100 00-1
Boom Folding Control Valve Replacement	0172 00-1
Boom Folding Cylinder Replacement	0253 00-1
Boom Hydraulic System Hoses and Fittings Replacement	0182 00-1
Boom Lift Cylinder Replacement	0252 00-1
Boom Support Locking Pin Cylinder Replacement	0254 00-1
Boom Support Replacement	0281 00-1
Boom Wiring Harnesses Replacement	0220 00-1
Boom-to-Boom Extension Flexible Conveyer Maintenance	0163 00-1
Brake	
Axle, Cooling System Troubleshooting	0032 00-1
Cooling Filter Replacement	0128 00-1
Filter Head Replacement	0128 00-1
System Charging Valve Pressure Adjustment	0129 00-1
System Troubleshooting	0031 00-1
Brake Accumulator Replacement	0230 00-1
Brake and Steering Accumulator Service	0231 00-1
Brake Inching Switch Replacement	0097 00-1

INDEX - Continued

Subject *Work Package/Page*

B - Continued

Brake Light Replacement	0098 00-1
Brake Pressure Switches Replacement	0098 00-1

C

Cab	
Air Filters Replacement	0192 00-1
Auxiliary Fan Replacement	0193 00-1
Cab Distribution Box	
Circuit Breakers Replacement	0074 00-1
Relays Replacement	0074 00-1
Cab Door Assembly Maintenance	0240 00-1
Cab Door Weatherseal Replacement	0153 00-1
Cab Heater	
Blower Motor Replacement	0191 00-1
Fan Replacement	0191 00-1
Cab Heater/Air Conditioning Unit Replacement	0264 00-1
Cab Interior Light Maintenance	0089 00-1
Cab Lifting Cylinder Replacement	0173 00-1
Cab Parking and Service Brake Hydraulic Hoses and Fittings Replacement	0177 00-1
Cab Position Proximity Switches Replacement	0076 00-1
Cab Sliding Cylinder Replacement	0174 00-1
Cab Transport Control Valve Replacement	0170 00-1
Cab Transport Hydraulic Hoses and Fittings Replacement	0181 00-1
Cab Transport Lift Maintenance	0138 00-1
Caging and Uncaging Parking Brake	0123 00-1
Calibration	
Boom	0259 00-1
Steering	0238 00-1
Tophandler	0259 00-1
Transmission	0225 00-1
Cam Follower Assembly Maintenance	0275 00-1
Camshaft and Drive Gear Replacement	0274 00-1
Chain, Spreader Replacement	0168 00-1
Circuit Breakers and Relays Replacement, Cab Distribution Box	0074 00-1
Control Valve Replacement	
Main	0249 00-1
Servo	0250 00-1
Steering	0236 00-1

INDEX - Continued

Subject *Work Package/Page*

C - Continued

Control Valve Replacement - Continued	
Tophandler	0251 00-1
Control Valve Solenoids Replacement	0171 00-1
Coolant Filter Replacement	0069 00-1
Cooling Fan Hydraulic Pump Drive Gear Replacement	0214 00-1
Cooling Fan Hydraulic Pump Replacement	0247 00-1
Cooling Fan Operation and Fan Control Troubleshooting	0010 00-1
Cooling System	
Expansion Tank Maintenance	0066 00-1
Hoses Replacement	0065 00-1
Crankshaft Replacement	0272 00-1
Cylinder	
Block Repair	0271 00-1
Head	
Repair	0200 00-1
Replacement	0199 00-1

D

Damper, Vibration, Replacement	0203 00-1
Data Plate Replacement	0160 00-1
Description and Data, Equipment	0002 00-1
Diagrams	0048 00-1
Directional Light Maintenance	0086 00-1
Dolly Wheel Maintenance	0130 00-1
Door Assembly, Cab, Maintenance	0240 00-1
Draining and Filling Radiator Assembly	0064 00-1

E

ECS Display Screen Replacement	0081 00-1
ECU-to-ECU Communications Troubleshooting	0014 00-1
Electric Horn Replacement	0105 00-1
Electrical General Maintenance Instructions	0113 00-1
Electronic Control Unit (ECU) Replacement	
Servo System	0080 00-1
Steering System	0080 00-1
Tophandler	0077 00-1
Transmission	0080 00-1

INDEX - Continued

<i>Subject</i>	<i>Work Package/Page</i>
E - Continued	
Electronic Control Unit (ECU) Troubleshooting	
Communications, ECU-to-ECU	0014 00-1
Engine	0018 00-1
Engine (794)	0015 00-1
Hydraulic Servo System (790)	0036 00-1
Input and Output Signals for Steering	0017 00-1
Input Voltage	0013 00-1
Steering (792)	0015 00-1
Supply Voltage	0016 00-1
Tophandler (791)	0012 00-1
Transmission (793)	0015 00-1
Electronic Joystick Assembly	
Replacement	0082 00-1
Wiring Harness Replacement	0083 00-1
Emergency Steering Pump Replacement	0235 00-1
Engine	
Air Cleaner Maintenance	0057 00-1
Air Intake Hose Replacement	0058 00-1
Air Intake Tubes Replacement	0058 00-1
Ambient Air Pressure Sensors and Circuits Troubleshooting	0022 00-1
Battery Voltage Circuits Troubleshooting	0025 00-1
Cover Maintenance	0148 00-1
Electronic Control Module (ECM) Replacement	0079 00-1
Fuel Injector Circuits Troubleshooting	0008 00-1
Fuel Pressure Sensors and Circuits Troubleshooting	0024 00-1
Oil Dipstick Hose Replacement	0054 00-1
Oil Fill Hose Replacement	0054 00-1
Oil Filter Replacement	0053 00-1
Oil Pressure Sensor Troubleshooting	0020 00-1
Oil Replacement	0053 00-1
Position Sensor Circuits Troubleshooting	0019 00-1
Pressure Sensor Troubleshooting	0023 00-1
Sensors Replacement	0094 00-1
Temperature Sensor and Circuits Troubleshooting	0021 00-1
TPS and Idle Validation Switch Troubleshooting	0009 00-1
Engine Assembly Replacement	0197 00-1
Engine Mounts and Lifting Brackets Replacement	0198 00-1
Equipment Description and Data	0002 00-1
Error Codes	0005 00-1
Ether Cold Start System Maintenance	0061 00-1

INDEX - Continued

Subject *Work Package/Page*

E - Continued

Exhaust Manifold Replacement	0210 00-1
Exhaust Pipe Replacement	0063 00-1
Expendable and Durable Items List	0290 00-1

F

Fender Assembly Maintenance	0149 00-1
Filter Indicator Sensors, Hydraulic, Replacement	0103 00-1
Fire Extinguisher Bracket Replacement	0161 00-1
Flywheel	
Assembly Replacement	0204 00-1
Housing Replacement	0205 00-1
Folding Cylinder, Boom, Replacement	0253 00-1
Fording Water Level Sensor Replacement	0091 00-1
Forklift Cylinder Replacement	0261 00-1
Forklift Kit Hydraulic Hoses and Fittings Replacement	0184 00-1
Front Axle Assembly Replacement	0227 00-1
Front Axle Steering Cylinders Replacement	0135 00-1
Front Axle Vent Hoses Replacement	0119 00-1
Front Gear	
Cover Replacement	0212 00-1
Housing Replacement	0278 00-1
Front Main Oil Seal Replacement	0201 00-1
Fuel Filter/Water Separator Replacement	0059 00-1
Fuel Hoses, Lines, and Fittings Replacement	0060 00-1
Fuel Injector Circuits, Engine, Troubleshooting	0008 00-1
Fuel Injector Replacement	0215 00-1
Fuel Level Sending Unit Replacement	0095 00-1
Fuel Pump Assembly Replacement	0216 00-1
Fuel Solenoid Shutoff Valve Replacement	0056 00-1
Fuel Tank Replacement	0218 00-1

G

Gear, Front, Cover Replacement	0212 00-1
General Information	0001 00-1
General Maintenance Instructions	0284 00-1
General Maintenance Instructions, Electrical	0113 00-1

INDEX - Continued

<i>Subject</i>	<i>Work Package/Page</i>
H	
Headlight Maintenance	0084 00-1
Heater Hoses Replacement	0190 00-1
Heater, Cab, Replacement	0264 00-1
Hydraulic	
Filter Indicators Troubleshooting	0039 00-1
Piston Pump Cut-Off Troubleshooting	0038 00-1
Hydraulic Cooling Fan Maintenance	0248 00-1
Hydraulic Cylinder Repair	
Cab Lift and Sideshift	0279 00-1
Tophandler, Sideshift, Leveling, Locking Pin, and Forklift Kit	0280 00-1
Hydraulic Filter Indicator Sensors Replacements	0103 00-1
Hydraulic Hoses and Fittings Replacement	
Boom System	0182 00-1
Cab Parking and Service Brake	0177 00-1
Cab Transport	0181 00-1
Forklift Kit	0184 00-1
Main System	0178 00-1
Parking Brake System	0125 00-1
Service Brake System	0127 00-1
Servo System	0179 00-1
Test Point System	0180 00-1
Tophandler System	0183 00-1
Hydraulic Pump Replacement	
Boom and Brake System	0246 00-1
Cooling Fan	0247 00-1
Hydraulic Reservoir	
Draining	0186 00-1
Filling	0186 00-1
Sensor Replacement	0102 00-1
Sight Gage Replacement	0187 00-1
Hydraulic Reservoir Replacement	0262 00-1
Hydraulic System	
Cooling Hoses and Fittings Replacement	0176 00-1
Oil Filters Replacement	0185 00-1
Relieving Pressure	0164 00-1
Test Point Procedures	0188 00-1
Valve Maintenance	0263 00-1
Hydraulic System Test Point Hoses and Fittings Replacement	0180 00-1

INDEX - Continued

<i>Subject</i>	<i>Work Package/Page</i>
I	
Idler Gears and Camshaft Drive Gear Replacement	0276 00-1
Illustrated List of Manufactured Items	0285 00-1
Infrared (IR) Lights Replacement	0090 00-1
Instrument Panel	
Gages Replacement	0073 00-1
Panel Lamps Replacement	0073 00-1
Switches Replacement	0073 00-1
Intake Manifold Replacement	0211 00-1
J	
Junction Box, Tophandler, Replacement	0222 00-1
L	
Leak Test, Air Conditioner	0194 00-1
Left-Side Stair Assembly Maintenance	0140 00-1
Leveling Cylinder, Tophandler	0257 00-1
Lift Cylinder, Boom, Replacement	0252 00-1
Light Maintenance	
Backup	0085 00-1
Blackout	0087 00-1
Cab Interior	0089 00-1
Directional	0086 00-1
Side Marker	0086 00-1
Twistlock Indicator	0088 00-1
Work	0085 00-1
Load Testing Procedure	0291 00-1
Locking Pin Bushing Replacement	0239 00-1
M	
Main Control Valve Replacement	0249 00-1
Main Hydraulic System Hoses and Fittings Replacement	0178 00-1
Maintenance	
Accessory Drive Assembly	0213 00-1
Air Conditioning System	0265 00-1
Bogie Wheel Assembly	0233 00-1
Cab Door Assembly	0240 00-1
Cam Follower Assembly	0275 00-1
Hydraulic Cooling Fan	0248 00-1
Oil Filter Head and Oil Cooler	0209 00-1
Oil Pump Assembly	0277 00-1

INDEX - Continued

Subject *Work Package/Page*

M - Continued

Maintenance - Continued	
Parking Brake Cylinder	0229 00-1
Piston and Connecting Rod	0273 00-1
Rocker Arm Assembly	0206 00-1
Maintenance Allocation Chart (MAC)	
Introduction	0288 00-1
Table	0289 00-1
Manifold	
Exhaust, Replacement	0210 00-1
Intake, Replacement	0211 00-1
Master Battery Switch Replacement	0111 00-1
Mirrors, Rearview, Replacement	0157 00-1
Mounting Engine on Rebuild Stand	0270 00-1
Mudguard Replacement	0150 00-1
Muffler Replacement	0063 00-1

O

Oil Cooler, Transmission, Replacement	0226 00-1
Oil Filter Head and Oil Cooler Maintenance	0209 00-1
Oil Pan Replacement	0208 00-1
Oil Pump Assembly Maintenance	0277 00-1
Oil Sampling Valve Hose Replacement	
Engine	0055 00-1
Hydraulic System	0055 00-1
Transmission	0055 00-1
Oil Sampling Valve Replacement	0055 00-1
Oil Seal Replacement	
Front Main	0201 00-1
Rear Main	0202 00-1
Overload Protection Troubleshooting	0011 00-1

P

Parking Brake	
Caging	0123 00-1
Control Valve Replacement	0124 00-1
Pads Maintenance	0122 00-1
System Hydraulic Hoses and Fittings Replacement	0125 00-1
Uncaging	0123 00-1
Parking Brake Cylinder Maintenance	0229 00-1

INDEX - Continued

Subject *Work Package/Page*

P - Continued

Piston and Connecting Rod Maintenance	0273 00-1
Preparation for Arctic Operation	0282 00-1
Preparation for Storage or Shipment	0283 00-1
Preventive Maintenance Checks and Services (PMCS)	
Introduction	0050 00-1
Table	0051 00-1
Propeller Shaft	
Front Replacement	0120 00-1
Rear Replacement	0120 00-1
Universal Joint Replacement	0121 00-1

R

Radiator	
Fill Cover Plate Replacement	0145 00-1
Splash Shield Replacement	0143 00-1
Top Grating Replacement	0144 00-1
Radiator Assembly	
Draining	0064 00-1
Filling	0064 00-1
Replacement	0219 00-1
Rear Axle Assembly Replacement	0228 00-1
Rear Axle Steering Cylinders Replacement	0135 00-1
Rear Axle Vent Hoses Replacement	0119 00-1
Rear Main Oil Seal Replacement	0202 00-1
References	0287 00-1
Relieving Hydraulic System Pressure	0164 00-1
Remote Hydraulic Control Compartment Replacement	0156 00-1
Repair	
Cylinder Block	0271 00-1
Cylinder Head	0200 00-1
Steering Column	0234 00-1
Reservoir, Hydraulic, Replacement	0262 00-1
Rifle Mounting Bracket Replacement	0162 00-1
Right-Side Step Assembly Replacement	0139 00-1
Rocker Arm	
Cover Replacement	0052 00-1
Gasket Replacement	0052 00-1
Rocker Arm Assembly Maintenance	0206 00-1

INDEX - Continued

<i>Subject</i>	<i>Work Package/Page</i>
S	
Seat	
Assembly Maintenance	0152 00-1
Belt Replacement	0151 00-1
Warning Buzzer Replacement	0107 00-1
Sensor Replacement	
Boom Angle	0099 00-1
Boom Extension	0100 00-1
Hydraulic Reservoir	0102 00-1
Lift Cylinder	0102 00-1
Tophandler Angle	0101 00-1
Service Brake	
Control Valve Replacement	0126 00-1
System Hydraulic Hoses and Fittings Replacement	0127 00-1
Service Upon Receipt	
Inspection Instructions	0049 00-1
Servicing Instructions	0049 00-1
Servo Control Valve Replacement	0250 00-1
Shipment, Preparation for	0283 00-1
Side Marker Light Maintenance	0086 00-1
Sideshifting Cylinder, Tophandler	0256 00-1
Slave Starting Receptacle Replacement	0112 00-1
Slewing Motor Brake Replacement	0244 00-1
Solar Charger Maintenance (USMC Only)	0109 00-1
Spreader	
20 and 40 Foot Adjustment	0169 00-1
Maintenance	0245 00-1
Stair Assembly, Left-Side, Maintenance	0140 00-1
Starter Replacement	0072 00-1
Steering	
Accumulator Replacement	0237 00-1
Brake Pedal Maintenance	0132 00-1
Calibration	0238 00-1
Column Base Maintenance	0132 00-1
Column Repair	0234 00-1
Column Replacement	0133 00-1
Column Sensor Replacement	0136 00-1
Control Valve Replacement	0236 00-1
Cylinders, Front and Rear Axle, Replacement	0135 00-1
Emergency Pump	0235 00-1

INDEX - Continued

Subject *Work Package/Page*

S - Continued

Steering - Continued	
Hydraulic Pumps Adjustment	0243 00-1
Hydraulic Pumps Replacement	0242 00-1
Mechanical or Hydraulic, Failure Troubleshooting	0034 00-1
Sensor Troubleshooting	0035 00-1
System Hydraulic Hoses and Fittings Replacement	0134 00-1
Valve Circuit Troubleshooting	0033 00-1
Wheel Replacement	0131 00-1
Steering System Wheel Sensor Replacement	0104 00-1
Step Assembly, Right-Side, Replacement	0139 00-1
Storage Compartment	
Battery and Dolly Wheels Replacement	0155 00-1
Doors Replacement	0154 00-1
Latches Replacement	0154 00-1
Storage, Preparation for	0283 00-1

T

Theory of Operation	0003 00-1
Air Conditioning System	0003 00-3
Brake System	0003 00-2
Cab System	0003 00-3
Cooling System	0003 00-1
Drive Train	0003 00-1
Electrical System	0003 00-1
Electronic System	0003 00-3
Exhaust System	0003 00-1
Forklift Kit	0003 00-4
Fuel System	0003 00-1
Hydraulic System	0003 00-2
Lifting Boom and Tophandler	0003 00-4
Steering System	0003 00-2
Thermostat Replacement	0067 00-1
Throttle Position Sensor Replacement (Accelerator Pedal)	0062 00-1
Tilt Cylinder, Tophandler, Replacement	0255 00-1
Tophandler	
Angle Sensor Replacement	0101 00-1
Calibration	0259 00-1
Control Valve Replacement	0251 00-1
Forklift Sensor Troubleshooting	0047 00-1
Hydraulic Pump Adjustment	0243 00-1
Hydraulic Pump Assembly Replacement	0242 00-1

INDEX - Continued

Subject

Work Package/Page

T - Continued

Tophandler - Continued

Hydraulic Slewing Motors Replacement	0166 00-1
Hydraulic Spreader Motor Replacement	0167 00-1
Hydraulic System Hoses and Fittings Replacement	0183 00-1
Junction Box Maintenance	0077 00-1
Junction Box Replacement	0222 00-1
Leveling Cylinder Replacement	0257 00-1
Leveling Troubleshooting	0044 00-1
Proximity Switch Junction Boxes Replacement	0078 00-1
Proximity Switches Replacement	0075 00-1
Replacement	0189 00-1
Sideshift Troubleshooting	0045 00-1
Sideshifting Cylinder Replacement	0256 00-1
Slewing Troubleshooting	0042 00-1
Spreader Troubleshooting	0046 00-1
Tilt Cylinder Replacement	0255 00-1
Tilt Troubleshooting	0043 00-1
Twistlock Cylinder Replacement	0175 00-1
Twistlock Replacement	0260 00-1
Twistlocks Sensor Troubleshooting	0047 00-1
Wear Plates Replacement	0147 00-1
Wiring Harnesses Replacement	0221 00-1
Tophandler Electronic Control Unit (ECU) (791) Troubleshooting	0012 00-1
Torque Converter, Transmission, Replacement	0223 00-1
Torque Limits	0286 00-1
Tow Pintle Replacement	0137 00-1
Transmission	
Access Covers Replacement	0142 00-1
Assembly Replacement	0224 00-1
Calibration	0225 00-1
Clutch Circuit Troubleshooting	0028 00-1
Control Lever Replacement	0114 00-1
Hydraulic Hoses, Assembly, Replacement	0116 00-1
Hydraulic Pipes, Assembly, Replacement	0116 00-1
Internal, Clutch Slippage Failure Troubleshooting	0030 00-1
Miscellaneous Failure Troubleshooting	0029 00-1
Oil Cooler Replacement	0226 00-1
Oil Dipstick Hose Replacement	0118 00-1
Oil Dipstick Pipe Replacement	0118 00-1
Oil Filter and Oil Cooler Hoses and Fittings Replacement	0115 00-1
Oil Filter Head Replacement	0117 00-1

INDEX - Continued

Subject *Work Package/Page*


T - Continued

Transmission - Continued	
Oil Filters Replacement	0117 00-1
Oil Replacement	0117 00-1
Sensors Replacement	0096 00-1
Skid Plate Replacement	0142 00-1
Speed Sensors Troubleshooting	0027 00-1
Temperature Troubleshooting	0026 00-1
Torque Converter Replacement	0223 00-1
Vent Hoses Replacement	0119 00-1
Troubleshooting	
Introduction	0004 00-1
Non-Error Code Procedures	0007 00-1
Symptom Index	0006 00-1
Turbocharger Replacement	0217 00-1
Twistlock Indicator Lights Maintenance	0088 00-1
U	
Universal Joint, Propeller Shaft, Replacement	0121 00-1
V	
Valve and Injector Adjustments	0207 00-1
Vibration Damper Replacement	0203 00-1
W	
Water Pump Replacement	0068 00-1
Wear Plates	
Boom Assembly	0146 00-1
Tophandler	0147 00-1
Wheel and Tire Replacement	0232 00-1
Wheel Temperature Sensor Replacement	0093 00-1
Windshield	
Washer Pump Replacement	0159 00-1
Washer Reservoir Replacement	0159 00-1
Wiper Maintenance	0158 00-1
Windshield and Window Glass Replacement	0241 00-1
Wiring Harnesses	
Boom	0220 00-1
Tophandler	0221 00-1
Work Light Maintenance	0085 00-1

By Order of the Secretary of the Army:

PETER J. SCHOOMAKER
General, United States Army
Chief of Staff

Official:


JOYCE E. MORROW
Administrative Assistant to the
Secretary of the Army
0631805

BY DIRECTION OF THE COMMANDANT OF THE MARINE CORPS
G.W. TAYLOR
Product Group Director, PG-15
Ground Transportation Engineer Systems
Marine Corps Systems Command

ARMY DISTRIBUTION: To be distributed in accordance with the initial distribution requirements for IDN: 256668
TM 10-3930-675-24-1.

MARINE CORPS DISTRIBUTION: PCN 184 110782 00

These are the instructions for sending an electronic 2028

The following format must be used if submitting an electronic 2028. The subject line must be exactly the same and all fields must be included; however, only the following fields are mandatory: 1, 3, 4, 5, 6, 7, 8, 9, 10, 13, 15, 16, 17 and 27.

From: "Whoever" whoever@avma27.army.mil
To: tacom-tech-pubs@tacom.army.mil

Subject DA Form 2028

1. ***From:*** Joe Smith
2. ***Unit:*** home
3. ***Address:*** 4300 Park
4. ***City:*** Hometown
5. ***St:*** MO
6. ***Zip:*** 77777
7. ***Date Sent:*** 19-OCT-93
8. ***Pub no:*** 55-1915-200-10
9. ***Pub Title:*** TM
10. ***Publication Date:*** 11-APR-88
11. ***Change Number:*** 12
12. ***Submitter Rank:*** MSG
13. ***Submitter Fname:*** Joe
14. ***Submitter Mname:*** T
15. ***Submitter Lname:*** Smith
16. ***Submitter Phone:*** 123-123-1234
17. ***Problem:*** 1
18. ***Page:*** 1
19. ***Paragraph:*** 3
20. ***Line:*** 4
21. ***NSN:*** 5
22. ***Reference:*** 6
23. ***Figure:*** 7
24. ***Table:*** 8
25. ***Item:*** 9
26. ***Total:*** 123
27. ***Text:***

This is the text for the problem below line 27.

RECOMMENDED CHANGES TO PUBLICATIONS AND BLANK FORMS For use of this form, see AR 25-30; the proponent agency is OAASA						Use Part II (<i>reverse</i>) for Repair Parts and Special Tool Lists (RPSTL) and Supply Catalogs/Supply Manuals (SC/SM).	DATE 1 July 2007	
TO: (<i>Forward to proponent of publication or form</i>) (<i>Include ZIP Code</i>) AMSTA-LC-LPIT/TECH PUBS, TACOM-RI 1 Rock Island Arsenal Rock Island, IL 61299-7630						FROM: (<i>Activity and location</i>) (<i>Include ZIP Code</i>)		
PART I - ALL PUBLICATIONS (EXCEPT RPSTL AND SC/SM) AND BLANK FORMS								
PUBLICATION/FORM NUMBER TM 10-3930-675-24-1						DATE .1 December 2006	TITLE Field and Sustainment Maintenance Manual (Includes Unit, Direct and General Support) for the Rough Terrain Container Handler (RTCH-RT-240)	
ITEM	PAGE	PARA-	LINE	FIGURE NO.	TABLE	RECOMMENDED CHANGES AND REASON		
	0017 00-2					Part number supplied for item 2 is incorrect.		
TYPED NAME, GRADE OR TITLE						TELEPHONE EXCHANGE/AUTOVON, PLUS EXTENSION		SIGNATURE

SAMPLE

TO: (Forward direct to addressee listed in publication)

FROM: (Activity and location) (Include ZIP Code)

DATE

AMSTA-LC-LPIT/TECH PUBS, TACOM-RI
1 Rock Island Arsenal
Rock Island, IL 61299-7630

PART II - REPAIR PARTS AND SPECIAL TOOL LISTS AND SUPPLY CATALOGS/SUPPLY MANUALS

PUBLICATION NUMBER

DATE

TITLE

PAGE NO.	COLM NO.	LINE NO.	NATIONAL STOCK NUMBER	REFERENCE NO.	FIGURE NO.	ITEM NO.	TOTAL NO. OF MAJOR ITEMS SUPPORTED	RECOMMENDED ACTION
----------	----------	----------	-----------------------	---------------	------------	----------	------------------------------------	--------------------

SAMPLE

PART III - REMARKS

(Use this section for remarks, references, or suggestions for improvement of publications and for additional sheets that may be used. Space is provided.)

TYPED NAME, GRADE OR TITLE

TELEPHONE EXCHANGE/AUTOVON,
PLUS EXTENSION

SIGNATURE

RECOMMENDED CHANGES TO PUBLICATIONS AND BLANK FORMS For use of this form, see AR 25-30; the proponent agency is OAASA						Use Part II (<i>reverse</i>) for Repair Parts and Special Tool Lists (RPSTL) and Supply Catalogs/Supply Manuals (SC/SM).	DATE
TO: (<i>Forward to proponent of publication or form</i>) (<i>Include ZIP Code</i>) AMSTA-LC-LPIT/TECH PUBS, TACOM-RI 1 Rock Island Arsenal Rock Island, IL 61299-7630						FROM: (<i>Activity and location</i>) (<i>Include ZIP Code</i>)	
PART I - ALL PUBLICATIONS (EXCEPT RPSTL AND SC/SM) AND BLANK FORMS							
PUBLICATION/FORM NUMBER TM 10-3930-675-24-1						DATE 1 December 2006	TITLE Field and Sustainment Maintenance Manual (Includes Unit, Direct and General Support) for the Rough Terrain Container Handler (RTCH-RT-240)
ITEM	PAGE	PARA-	LINE	FIGURE NO.	TABLE	RECOMMENDED CHANGES AND REASON	
TYPED NAME, GRADE OR TITLE					TELEPHONE EXCHANGE/AUTOVON, PLUS EXTENSION		SIGNATURE

TO: *(Forward direct to addressee listed in publication)*

AMSTA-LC-LPIT/TECH PUBS, TACOM-RI
1 Rock Island Arsenal
Rock Island, IL 61299-7630

FROM: *(Activity and location) (Include ZIP Code)*

DATE

PART II - REPAIR PARTS AND SPECIAL TOOL LISTS AND SUPPLY CATALOGS/SUPPLY MANUALS

PUBLICATION NUMBER

DATE

TITLE

PAGE NO.	COLM NO.	LINE NO.	NATIONAL STOCK NUMBER	REFERENCE NO.	FIGURE NO.	ITEM NO.	TOTAL NO. OF MAJOR ITEMS SUPPORTED	RECOMMENDED ACTION
----------	----------	----------	-----------------------	---------------	------------	----------	------------------------------------	--------------------

PART III - REMARKS *(Any general remarks or recommendations, or suggestions for improvement of publications and blank forms. Additional blank sheets may be used if more space is needed.)*

TYPED NAME, GRADE OR TITLE

TELEPHONE EXCHANGE/AUTOVON,
PLUS EXTENSION

SIGNATURE

RECOMMENDED CHANGES TO PUBLICATIONS AND BLANK FORMS For use of this form, see AR 25-30; the proponent agency is OAASA						Use Part II (<i>reverse</i>) for Repair Parts and Special Tool Lists (RPSTL) and Supply Catalogs/Supply Manuals (SC/SM).	DATE
TO: (<i>Forward to proponent of publication or form</i>) (<i>Include ZIP Code</i>) AMSTA-LC-LPIT/TECH PUBS, TACOM-RI 1 Rock Island Arsenal Rock Island, IL 61299-7630						FROM: (<i>Activity and location</i>) (<i>Include ZIP Code</i>)	
PART I - ALL PUBLICATIONS (EXCEPT RPSTL AND SC/SM) AND BLANK FORMS							
PUBLICATION/FORM NUMBER TM 10-3930-675-24-1						DATE 1 December 2006	TITLE Field and Sustainment Maintenance Manual (Includes Unit, Direct and General Support) for the Rough Terrain Container Handler (RTCH-RT-240)
ITEM	PAGE	PARA-	LINE	FIGURE NO.	TABLE	RECOMMENDED CHANGES AND REASON	
TYPED NAME, GRADE OR TITLE					TELEPHONE EXCHANGE/AUTOVON, PLUS EXTENSION		SIGNATURE

TO: *(Forward direct to addressee listed in publication)*

FROM: *(Activity and location) (Include ZIP Code)*

DATE

AMSTA-LC-LPIT/TECH PUBS, TACOM-RI
1 Rock Island Arsenal
Rock Island, IL 61299-7630

PART II - REPAIR PARTS AND SPECIAL TOOL LISTS AND SUPPLY CATALOGS/SUPPLY MANUALS

PUBLICATION NUMBER

DATE

TITLE

PAGE NO.	COLM NO.	LINE NO.	NATIONAL STOCK NUMBER	REFERENCE NO.	FIGURE NO.	ITEM NO.	TOTAL NO. OF MAJOR ITEMS SUPPORTED	RECOMMENDED ACTION
----------	----------	----------	-----------------------	---------------	------------	----------	------------------------------------	--------------------

PART III - REMARKS *(Any general remarks or recommendations, or suggestions for improvement of publications and blank forms. Additional blank sheets may be used if more space is needed.)*

TYPED NAME, GRADE OR TITLE

TELEPHONE EXCHANGE/AUTOVON,
PLUS EXTENSION

SIGNATURE

RECOMMENDED CHANGES TO PUBLICATIONS AND BLANK FORMS For use of this form, see AR 25-30; the proponent agency is OAASA						Use Part II (<i>reverse</i>) for Repair Parts and Special Tool Lists (RPSTL) and Supply Catalogs/Supply Manuals (SC/SM).	DATE
TO: (<i>Forward to proponent of publication or form</i>) (<i>Include ZIP Code</i>) AMSTA-LC-LPIT/TECH PUBS, TACOM-RI 1 Rock Island Arsenal Rock Island, IL 61299-7630						FROM: (<i>Activity and location</i>) (<i>Include ZIP Code</i>)	
PART I - ALL PUBLICATIONS (EXCEPT RPSTL AND SC/SM) AND BLANK FORMS							
PUBLICATION/FORM NUMBER TM 10-3930-675-24-1						DATE 1 December 2006	TITLE Field and Sustainment Maintenance Manual (Includes Unit, Direct and General Support) for the Rough Terrain Container Handler (RTCH-RT-240)
ITEM	PAGE	PARA-	LINE	FIGURE NO.	TABLE	RECOMMENDED CHANGES AND REASON	
TYPED NAME, GRADE OR TITLE					TELEPHONE EXCHANGE/AUTOVON, PLUS EXTENSION		SIGNATURE

TO: *(Forward direct to addressee listed in publication)*

AMSTA-LC-LPIT/TECH PUBS, TACOM-RI
1 Rock Island Arsenal
Rock Island, IL 61299-7630

FROM: *(Activity and location) (Include ZIP Code)*

DATE

PART II - REPAIR PARTS AND SPECIAL TOOL LISTS AND SUPPLY CATALOGS/SUPPLY MANUALS

PUBLICATION NUMBER

DATE

TITLE

PAGE NO.	COLM NO.	LINE NO.	NATIONAL STOCK NUMBER	REFERENCE NO.	FIGURE NO.	ITEM NO.	TOTAL NO. OF MAJOR ITEMS SUPPORTED	RECOMMENDED ACTION
----------	----------	----------	-----------------------	---------------	------------	----------	------------------------------------	--------------------

PART III - REMARKS *(Any general remarks or recommendations, or suggestions for improvement of publications and blank forms. Additional blank sheets may be used if more space is needed.)*

TYPED NAME, GRADE OR TITLE

TELEPHONE EXCHANGE/AUTOVON,
PLUS EXTENSION

SIGNATURE

THE METRIC SYSTEM AND EQUIVALENTS

<p>Linear Measure</p> <p>1 Centimeter = 10 Millimeters = 0.01 Meters = 0.3937 Inches 1 Meter = 100 Centimeters = 1000 Millimeters = 39.37 Inches 1 Kilometer = 1000 Meters = 0.621 Miles</p> <p>Weights</p> <p>1 Gram = 0.001 Kilograms = 1000 Milligrams = 0.035 Ounces 1 Kilogram = 1000 Grams = 2.2 Pounds 1 Metric Ton = 1000 Kilograms = 1 Megagram = 1.1 Short Tons</p> <p>Liquid Measure</p> <p>1 Milliliter = 0.001 Liters = 0.0338 Fluid Ounces 1 Liter = 1000 Milliliters = 33.82 Fluid Ounces</p>	<p>Square Measure</p> <p>1 Sq Centimeter = 100 Sq Millimeters = 0.155 Sq Inches 1 Sq Meter = 10,000 Sq Centimeters = 10.76 Sq Feet 1 Sq Kilometer = 1,000,000 Sq Meters = 0.386 Sq Miles</p> <p>Cubic Measure</p> <p>1 Cu Centimeter = 1,000 Cu Millimeters = 0.06 Cu Inches 1 Cu Meter = 1,000,000 Cu Centimeters = 35.31 Cu Feet</p> <p>Temperature</p> <p>$5/9 (^{\circ}\text{F} - 32) = ^{\circ}\text{C}$ 212° Fahrenheit is equivalent to 100° Celsius 90° Fahrenheit is equivalent to 32.2° Celsius 32° Fahrenheit is equivalent to 0° Celsius $9/5 \text{ C}^{\circ} + 32 = \text{F}^{\circ}$</p>
--	--

APPROXIMATE CONVERSION FACTORS

To Change	To	Multiply By
Inches	Centimeters	2.540
Feet	Meters	0.305
Yards	Meters	0.914
Miles	Kilometers	1.609
Sq Inches	Sq Centimeters	6.451
Sq Feet	Sq Meters	0.093
Sq Yards	Sq Meters	0.836
Sq Miles	Sq Kilometers	2.590
Acres	Sq Hectometers	0.405
Cubic Feet	Cubic Meters	0.028
Cubic Yards	Cubic Meters	0.765
Fluid Ounces	Milliliters	29.573
Pints	Liters	0.473
Quarts	Liters	0.946
Gallons	Liters	3.785
Ounces	Grams	28.349
Pounds	Kilograms	0.454
Short Tons	Metric Tons	0.907
Pound-Feet	Newton-Meters	1.356
Pounds per Sq Inch	Kilopascals	6.895
Miles per Gallon	Kilometers per Liter	0.425
Miles per Hour	Kilometers per Hour	1.609

To Change	To	Multiply By
Centimeters	Inches	0.394
Meters	Feet	3.280
Meters	Yards	1.094
Kilometers	Miles	0.621
Sq Centimeters	Sq Inches	0.155
Sq Meters	Sq Feet	10.764
Sq Meters	Sq Yards	1.196
Sq Kilometers	Sq Miles	0.386
Sq Hectometers	Acres	2.471
Cubic Meters	Cubic Feet	35.315
Cubic Meters	Cubic Yards	1.308
Milliliters	Fluid Ounces	0.034
Liters	Pints	2.113
Liters	Quarts	1.057
Liters	Gallons	0.264
Grams	Ounces	0.035
Kilograms	Pounds	2.205
Metric Tons	Short Tons	1.102
Newton-Meters	Pound-Feet	0.738
Kilopascals	Pounds per Sq Inch	0.145
Kilometers per Liter	Miles per Gallon	2.354
Kilometers per Hour	Miles per Hour	0.621

